

**Operator's Manual &
Illustrated Parts List**

**Model X900
Manure Spreader**



Art's Way Manufacturing

690941

Issued April 2026



OPERATOR'S MANUAL

ART'S WAY

TABLE OF CONTENTS	
NAME	PAGE
-----OPERATOR'S MANUAL-----	1
--IDENTIFICATION OF MACHINE--	6
Model and Serial Number Designations	6
Serial Number Record and Location	6
--INTRODUCTION--	7
Importance of This Manual	7
Sources of Assistance	7
Statement of Product Liability	7
Subject to Change	8
Interpretation of Information	8
Intended Use	9
--SAFETY INFORMATION--	10
General	10
Safety Alert Symbol	11
Signal Words	12
Preparation for Use	12
Normal Operation and Service	13
Clearing Blockages and Cleaning	14
Transport	14
Maintenance and Adjustment	15
Storage	16
X900 Specific Safety	17
Hydraulic Safety	18
Tire/Wheel Safety	18
Location of Safety Signs	19
Safety Signs Readability	19
Reproduction of Safety Signs	19
--OPERATION--	22
Controls and Displays	22
Controls and Displays Location	22
Controls and Displays Explanation of Symbols	23
Pre-Start Instructions	23
Starting, Stopping, and Shutdown	24
Functions and Adjustments	24
Troubleshooting	25
--ROUTINE MAINTENANCE AND ADJUSTMENTS--	26
Maintenance Schedules	26
Maintenance Procedures	27
Storage	29
--SPECIFICATIONS--	30
--AUXILIARY INFORMATION--	32

TABLE OF CONTENTS	
General	32
Reception	32
Assembly and Initial Setup	32
Transportation	33
Warranty	33
Accessories and Attachments	33
-----ILLUSTRATED PARTS LIST-----	35
HYDRAULICS ASSEMBLY	36
MANIFOLD ASSEMBLY	38
HYDRAULICS DIAGRAM	40
RUNNING GEAR ASSEMBLY	42
HUB ASSEMBLY	44
TONGUE ASSEMBLY	46
DRIVELINE ASSEMBLY	48
SHAFT ASSEMBLY (598080)	50
SHAFT ASSEMBLY (H160105) (21 SPLINE)	52
SHAFT ASSEMBLY (H160106) (20 SPLINE)	54
GREASE ASSEMBLY	56
MAIN FLOOR ASSEMBLY	58
REAR GANG ASSEMBLY	60
GEARBOX ASSEMBLY (HO74-01-5069)	62
LIGHTS ASSEMBLY	64
LIGHTS DIAGRAM	66
WHEEL ASSEMBLY (USED MILITARY)	68
WHEEL ASSEMBLY (RH GOODYEAR FLOATATION 690623)	70
WHEEL ASSEMBLY (LH GOODYEAR FLOATATION 690624)	71
WHEEL ASSEMBLY (RH BKT FLOATATION 690621)	72
WHEEL ASSEMBLY (LH BKT FLOATATION 690622)	73
APRON CHAIN ASSEMBLY	74
SLOP GATE ASSEMBLY	76
FLASHING ASSEMBLY	78
BEATERS ASSEMBLY	80
BEATERS ASSEMBLY (H160503) (GEN 1)	82
BEATERS ASSEMBLY (H160503) (GEN 2)	84
BEATERS GEARBOX ASSEMBLY (H14250)	86
LITTER KIT (OPTIONAL)	88
SHAFT ASSEMBLY (H160048)	90
ROCK GUARD ASSEMBLY	92
SHIELDS ASSEMBLY	94
MANUAL ASSEMBLY	96
DECALS ASSEMBLY	98
SCALE ASSEMBLY (ALL)	100

TABLE OF CONTENTS

SCALE ASSEMBLY (RAVEN ONLY)	101
SCALE DIAGRAM (GT400)	102
SCALE DIAGRAM (NT560)	103
SCALE DIAGRAM (RAVEN RCM-LVL3 ISOBUS)	104
SCALE DIAGRAM (RAVEN ISOBUS CR7 INDICATOR & GPS)	105

**THIS PAGE
LEFT
INTENTIONALLY
BLANK**

--IDENTIFICATION OF MACHINE--

Model and Serial Number Designations

This manual contains operating instructions for your X900 Manure Spreader only. Any mention of other machinery in this manual other than the X900 Manure Spreader is for reference only. This manual does not replace nor is it to be used for any machinery that may be attached to or used in conjunction with the X900 Manure Spreader.

This manual applies to equipment starting with the serial number: AWX900001464



Date of Purchase:

Dealer Name:

Dealer Contact Info:

Serial Number Record and Location

For your convenience, we have provided the above space for you to record your serial number, model number, the date of purchase, and your dealer's name and contact info.

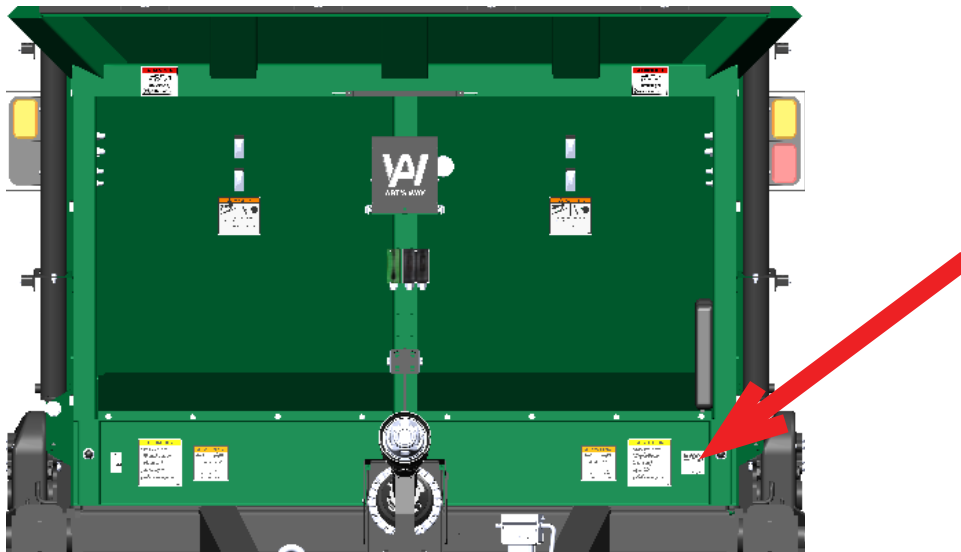

The location of your equipment's serial tag is shown above.
Manual No. 690941

--INTRODUCTION--

Importance of This Manual

Congratulations on the purchase of your new Art's Way Manure Spreader. You have selected a top quality machine that is designed and built with pride to ensure you have many years of efficient and reliable service. It is your responsibility to observe pertinent laws and regulations and to follow manufacturer's instructions on machine operation and maintenance.

Many people have worked on the design, production, and delivery of this Manure Spreader. The information in this manual is based on the knowledge, study, and experience through years of specializing in the manufacturing of farm machinery. This manual is designed to provide you with important information regarding safety, maintenance, and machine operation so you can and will get the best possible performance from your Manure Spreader.

If this machine is used by an employee, is loaned, or is rented, make sure that the operator reads and understands the operator's manual for this machine. As the owner also give instructions to the operator on safe and correct use of the machine.

Even if you are an experienced operator of this or similar equipment, we ask that you read this manual before operating this Manure Spreader. The way you operate, adjust, and maintain this unit will have much to do with its successful performance.

Sources of Assistance

Any further questions you may have about this product of Art's Way equipment should be directed to your local Art's Way dealer or to Art's Way Manufacturing Armstrong, Iowa, 50514, (712) 208-8467. Art's Way Manufacturing has an excellent dealership network ready to answer any questions you may have about your X900. Parts for your machine may be ordered through our dealers. When placing a parts order, please have the model and serial number ready. This will allow the dealer to fill your order as quickly as possible. See your Authorized Art's Way Manufacturing dealer or Art's Way Manufacturing for additional operator's manuals, illustrated parts catalogs, and service manuals. The most up-to-date digital copies can be found at artsway.com/resources/manuals

Statement of Product Liability

Art's Way Manufacturing recognizes its responsibility to provide customers with a safe and efficient product. Art's Way Manufacturing, attempts to design and manufacture its products in accordance with all accepted engineering practices effective at the date of design. This statement should not be interpreted to mean that our products will protect against the user's own carelessness or failure to follow common safety practices nor will Art's Way Manufacturing, be liable for any such act. In addition, Art's Way Manufacturing, assumes no liability for any altered product or any modified product by users or anyone other than an authorized dealer.

Subject to Change

Art's Way Manufacturing is continually making product improvements. In doing so, we reserve the right to make changes and/or add improvements to our products without obligation for the equipment previously sold.

Modifications and/or alterations to this Manure Spreader may affect the performance, function, and safety of its operation. Therefore, no modifications are to be made without the written permission of Art's Way Manufacturing. Any modification made without the written permission of Art's Way Manufacturing shall void the warranty of this product.

In the interest of continued safe operation of this Manure Spreader, pay particular attention to the safety alert symbol(s) throughout this manual.

Interpretation of Information

Art's Way Manufacturing designates "left-hand/LH" "right-hand/RH", or similar as the left and right side of the operator while sitting in the cab of a tractor facing forwards with the implement in question attached to the hitch or standing behind the implement looking forward unless specifically stated otherwise.

Art's Way Manufacturing designates "front" of the implement the side of the implement closest to the hitch and "rear" the side of the implement furthest away from the hitch.

"Tractor" or "vehicle" may refer to any moving power source.

"Machine", "implement", "unit", or "equipment" may refer to the product this manual has been supplied for.

Intended Use

This manure spreader is designed to spread agricultural organic material such as cattle manure. This unit is not designed to be a bedding machine, bale grinder, or hay chopper. The effectiveness of this machine relies on material type and consistency.

--SAFETY INFORMATION--**General**

Most work related accidents are caused by failure to observe basic safety rules or precautions. An accident can often be avoided by recognizing potentially hazardous situations before an accident occurs. As you operate and maintain the Spreader you must be alert to potential hazards. You should also have the necessary training, skills, and tools to perform any assembly procedure.

Improper operation and/or maintenance of this unit could cause a dangerous situation that results in injury or death.

Do not use this unit until you read and understand the information contained in this manual. Do not use this equipment for anything other than its intended purpose.



Safety precautions and warnings are provided in this manual and on the unit. If these hazard warnings are not heeded, bodily injury or death could occur to you or to other persons.

Art's Way Manufacturing cannot anticipate every possible circumstance that might involve a potential hazard. The warnings in this manual and on the product are, therefore, not all-inclusive. If a method of operation not specifically recommended by us is used, you must satisfy yourself that it is safe for you and for others. You should also ensure that the unit will not be damaged or be made unsafe by the methods that you choose.

The information, specifications, and illustrations in this manual are based on the information that was available at the time this material was written and can change at any time.



Read and understand the operator's manual and all the safety decals before operating the X900. Review all safety instructions with all operators annually.

"A careful operator is the best insurance against an accident." Quote from the National Safety Council.

Most accidents can be prevented if the operator:

1. Fully understands how the machine functions.
2. Can anticipate situations which may produce problems.
3. Can make necessary corrections before problems develop.

Remember:

"The Best Operator is a Safe Operator"

Do not allow operation of this X900 by an inexperienced or unqualified person. Keep all unqualified people away from the X900 during operation. Operators of this unit must be alert and use good judgement at all times and must have fully read and understand this manual.

Safety Alert Symbol

THIS SYMBOL MEANS ATTENTION!
BECOME ALERT!
YOUR SAFETY IS INVOLVED!



- Universal Safety Alert Symbol



This is the safety alert symbol. It is used to alert you to potential personal injury hazards. Obey all safety messages that follow this symbol to avoid possible injury or death.

This manual contains DANGERS, WARNINGS, CAUTIONS, NOTICES, SAFETY INSTRUCTIONS, and NOTES which must be followed to prevent the possibility of improper service, damage to the equipment, personal injury, or death. The following key words call the readers attention to potential hazards.

Hazards are identified by the "Safety Alert Symbol" and followed by a signal word such as "DANGER", "WARNING", or "CAUTION".

The American Society of Agricultural Engineers has adopted the Universal Safety Alert Symbol as a way to identify areas of potential danger if the equipment is not operated correctly. Please be alert whenever you see this symbol in the manuals or on your X900.

Art's Way Manufacturing strives to make our equipment as safe as possible. The Art's Way X900 Manure Spreader conforms to applicable safety standards at the time of manufacturing. A safety conscious equipment operator makes an effective accident-prevention program complete.

Safety features and instructions for the X900 are detailed in the Safety Guidelines section of this Operator's Manual. It is the responsibility of the owner to ensure that all operators read and understand the manual before they are allowed to operate the Spreader. (Occupational Safety and Health Administration (OSHA) regulations 1928.57).

Signal Words

Note the use of signal words DANGER, WARNING, and CAUTION on the X900 and in this manual. The appropriate signal word for each has been selected using the following guidelines:

DANGER

The signal word DANGER indicates an imminently hazardous situation which, if not avoided, will result in death or serious injury.

WARNING

The signal word WARNING indicates a potentially hazardous situation which, if not avoided, could result in death or serious injury.

CAUTION

The signal word CAUTION indicates a potentially hazardous situation which, if not avoided, may result in minor or moderate injury.

NOTICE

NOTICE is used to address practices not related to physical injury.

SAFETY INSTRUCTIONS

Safety instructions (or equivalent) signs indicate specific safety-related instructions or procedures.

Note: Contains additional information important to a procedure and will be found within the regular text body of this manual.

Preparation for Use

SAFETY INSTRUCTIONS



Do not wear loose fitting clothing as it may catch in moving parts.



Make sure all guards and shields are installed, including the tractor power take-off (PTO) master shield, before starting or operating the X900.



Be sure that the correct implement driveline parts are used and that they are properly secured.

Make sure the PTO is securely locked to both the tractor and X900 before operating the unit. Do not operate the PTO at speeds higher than the manufacturer's recommendation.

Put all tractor and machine controls in "neutral" and disengage the PTO before starting. Follow the starting instructions according to the OEM tractor manual.

Install and use adequate safety chain(s) when attaching the X900 to the tractor and while towing.



Clear the area of bystanders, especially children, when preparing the X900 for use.



Operate the X900 only while seated on the tractor seat.

Inspect when first delivered and regularly thereafter; that all connections and bolts are tight and secure before operating.

Normal Operation and Service

CAUTION



Entanglement Hazard
Keep hands, feet, hair, and clothing away from moving parts. Wait for all movement to stop before approaching equipment. Before making adjustments:

1. Shut off the tractor,
2. Set parking brake,
3. Put machine in neutral, and
4. Remove key while making adjustments.



Keep all shields and guards in place and in good working condition.



Keep all bystanders, especially children, away from the X900 while in operation.



Do not allow riders while the X900 is in operation.



Do not attempt to unclog, clean, or adjust the X900 while it is running.



Stay away from overhead power lines. Electrocutation can occur even without direct contact.



Keep all hydraulic lines, fittings, and couplers tight and free of leaks. (Refer to Safety Guidelines – Hydraulic Safety).



Avoid climbing on the machine if possible. Use caution when ascending or descending on the X900. Wet shoes or boots are slippery.

SAFETY INSTRUCTIONS

Follow all assembly, operating, and safety instructions found in this manual when assembly this equipment.



Use adequate manpower to perform assembly procedures safely.

Assemble the X900 in an area with sufficient space to maneuver the largest components and allow easy access to all sides of the machine.



Use only forklifts, lift cranes, jacks, and tools with sufficient capacity for the loads.



Do not allow spectators, especially children, in the working area.

Clearing Blockages and Cleaning



Before unclogging the machine, always make sure the tractor engine is stopped, key in your pocket, the machine is lowered to the ground (if applicable), all controls are placed in neutral, the parking brake is set, and all the moving parts have stopped. Disconnect the PTO and/or hydraulic remote connections after movement is stopped and pressure/flow is removed from the hydraulic system.

Be aware of the potential for stored energy. Do not use any body part to clean or clear debris if possible.

Consider surrounding objects or people that debris may come in contact with once removed. Stored energy could cause debris to be cleared with high velocity and in hard to predict directions.

Transport

SAFETY INSTRUCTIONS

Follow all operating and safety instructions found in this manual when transporting this equipment.

Make sure the X900 complies with all local regulations regarding transporting equipment on public roads and highways.



If equipped make sure the Slow Moving Vehicle (SMV) emblem and all lights and reflectors required by local highway and transportation authorities are properly in place, clean, and clearly visible to traffic.



Do not allow riders on any machinery during transport.

Make sure the X900 is securely attached to the tractor and install a safety chain to the X900.

Make sure the tractor brake pedals are latched together.

Do not exceed 20 mph (32 km/h) when transporting the X900. Always reduce speed on rough roads and surfaces, or when going down inclines.

Use caution when turning and always use the turn signals on the tractor to indicate your turning intentions to the other traffic.

The weight of the trailed machine should NEVER exceed the weight of the towing vehicle.

Check all clearances carefully whenever the machine is towed.

Set all features to transport position before transporting the X900 on the roadway.



Stay away from overhead obstructions and power lines during transport. Electrocutation can occur even without direct contact.

Maintenance and Adjustment

SAFETY INSTRUCTIONS

Follow all operating, maintenance, and safety instructions found in this Manual.



Before servicing, adjusting, or repairing the machine, always make sure the tractor engine is stopped, key in your pocket, the machine is lowered to the ground (if applicable), all controls are placed in neutral, the parking brake is set, and all the moving parts have stopped. Disconnect the PTO and/or hydraulic remote connections after movement is stopped and pressure/flow is removed from the hydraulic system.



Use sufficient tools, jacks, and hoists that have the capacity for the job.



Use support blocks or safety stands when changing tires or performing maintenance.



Follow good shop practices of keeping the service area clean and dry, and use adequate light for the job at hand.



Before applying pressure to the hydraulic system, make sure all lines, fittings, and couplers are tightly secured and in good condition.



Make sure all shields/guards are in place and properly secured when performing maintenance.

Storage

**SAFETY
INSTRUCTIONS**

Follow all operating and safety instructions found in this manual when storing this equipment.



Store the X900 in an area away from human activity.



Do not permit children to play on or around the stored machine at any time.

Make sure that the X900 is stored in an area with a firm and level base to prevent the machine from tipping or sinking into the ground.



Block the wheels ahead and behind to prevent the machine from rolling.

X900 Specific Safety

WARNING

When the spreader is in operation, it has many moving parts, which could cause severe injury or death to persons coming in contact with these parts. To help avoid serious accidents, the following guidelines must be followed.

Never put arms or feet inside unit, or near discharge areas, nor climb on or in the spreader while it is running.

Never allow anyone to position themselves over or near the top, or near the discharge area (near beaters) of the spreader while it is running. Rotating beaters, shafting, chains, and sprockets can grab clothing or create pinch points, which can cause severe injury or death to the operator or bystanders.

Always stop engine and remove ignition key so that the spreader cannot be accidentally turned on while inspection, servicing, repairing, or cleaning the spreader.

Never attempt to release jammed materials or clean materials from any area of the spreader or discharge without turning the spreader off first. Materials can hide moving parts and stopped parts can start unexpectedly, causing severe injury. Always stop engine and remove ignition key before attempting to remove jammed material or clean the spreader.

Be sure the inside of the spreader is clear of any obstructions before loading.

Do not allow anyone to ride inside the spreader at any time.

Be sure the tractor attached to the spreader is large enough and has adequate brakes to stop when fully loaded. Reduce speed while traveling loaded and/or over rough, soft, or wet terrain. Exercise caution on slopes, when turning corners, and when approaching stops. Highway transport is not to exceed 10 MPH while loaded. The tires supplied are for farm use only and are not designed for use above this speed when loaded.

When working on slopes or inclines, travel uphill or downhill. Keep the transmission in gear when going downhill. Avoid driving on loose fill, rocks, inclines, ditches, gullies, and holes.

Clear the area surrounding the unit before spreader startup. Do not go near or allow anyone near the spreader while the machine is operating.

Do not load the spreader unless it is hitched to the tractor.

Do not unhitch a loaded spreader from the tractor, leaving it supported by only the jack.

Do not lift the manure spreader by the box weldment "D-rings".

Do not work or position any body part underneath the slop gate.

Always wear eye protection when operating or servicing the spreader.

Hydraulic Safety

SAFETY INSTRUCTIONS

Follow all operating, maintenance, and safety instructions found in this Manual.

Make sure components in the hydraulic system are kept clean and in good working condition.



Relieve pressure from the hydraulic system before servicing or disconnecting from the tractor.



Keep all hydraulic lines, fittings, and couplers tightly secured and free of leaks.



Replace any worn, cut, abraded, flattened, or crimped hoses.



Do not make any temporary repairs to the hydraulic lines, fittings, or hoses using tape, clamps, or cement. The hydraulic system operates under extremely high pressure and temporary repairs may fail suddenly and create a hazardous/dangerous situation.



Wear proper hand and eye protection when searching for a high-pressure hydraulic leak. Use a piece of wood or cardboard as a backstop instead of hands to identify and isolate a leak. If injured by a concentrated high-pressure stream of hydraulic fluid, seek medical attention immediately. Serious infection or toxic reaction can develop if hydraulic fluid penetrates the surface of the skin.



Before applying pressure to the system, make sure all components are tight and that the hydraulic lines, hoses, and couplings are not damaged.

Tire/Wheel Safety

SAFETY INSTRUCTIONS

Follow all operating and safety instructions found in this manual when working around tires.

Have only a qualified tire dealer or tire repair service perform tire repairs.

Do not attempt to install a tire on a wheel or rim unless you have the proper equipment and experience to do the job.

Do not substitute tires with a lesser road rating and/or capacity for the original equipment tires.

Maintain proper tire air pressure at all times.

Retighten all wheel bolts after the first hour of towing. Check periodically thereafter.

Use support blocks and safety stands when changing tires or servicing other running gear components.

WARNING



Explosive Force Hazard
Tire replacement, repair, and/or maintenance should be done by a qualified tire dealer or qualified repair service.

Failure to follow proper procedures when installing a tire on a wheel or rim can produce an explosive force that will result in serious injury or death.

Do not attempt to install a tire without proper equipment and experience to perform the job.

Location of Safety Signs

Location of safety signs is shown in the Illustrated Parts List section of this manual or in an additional separate Illustrated Parts List manual included with your X900.

Safety Signs Readability

Your new Art's Way X900 comes with all safety signs properly affixed. You are responsible for keeping all these safety signs clean and legible. If any safety signs become illegible, damaged, or missing, you are responsible for ordering and replacing those signs before operating your X900. Any replacement parts for parts with safety signs affixed must also have the proper safety sign attached. All safety signs are available free of charge from Art's Way Manufacturing.

Reproduction of Safety Signs



Decal P/N: 346310

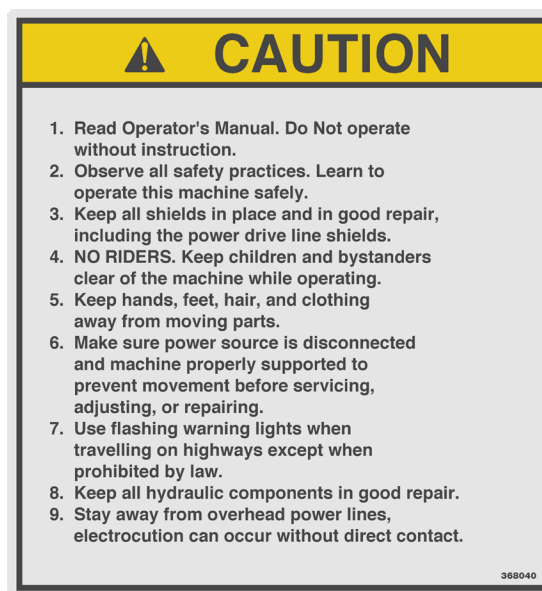

Decal P/N: 368040



Decal P/N: 384020



Decal P/N: 467455

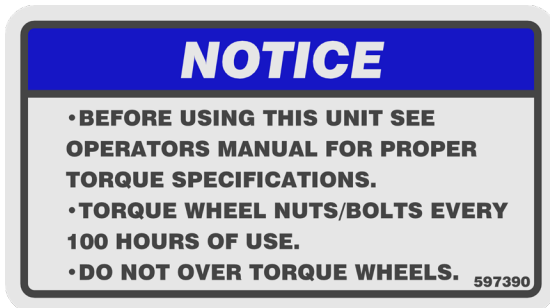

Decal P/N: 597390



Decal P/N: 720855



Decal P/N: HJ22-00-0080



Decal P/N: HJ22-00-0114

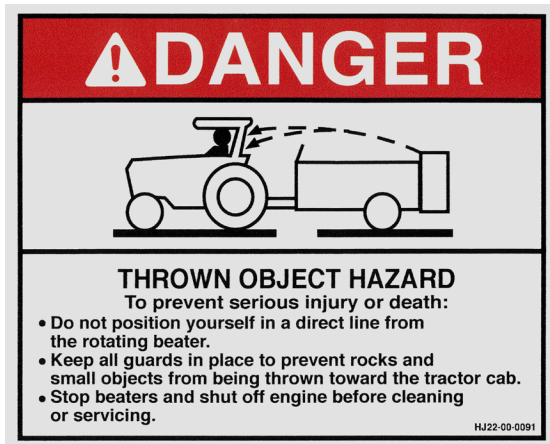

Decal P/N: HJ22-00-0091



Decal P/N: 487730

--OPERATION--

Controls and Displays

The X900 Manure Spreader is largely operated by the connected tractor's hydraulic and PTO engage/disengage controls. However additional controls for the apron chain do exist on the hydraulic manifold mounted to the unit. Circled in the image below are the two control knobs on the manifold that can be turned either clockwise/counterclockwise and/or locked in place. Additional controls and displays may exist for this unit based on optional add-ons. Please refer to the documentation included with those add-ons for additional information.

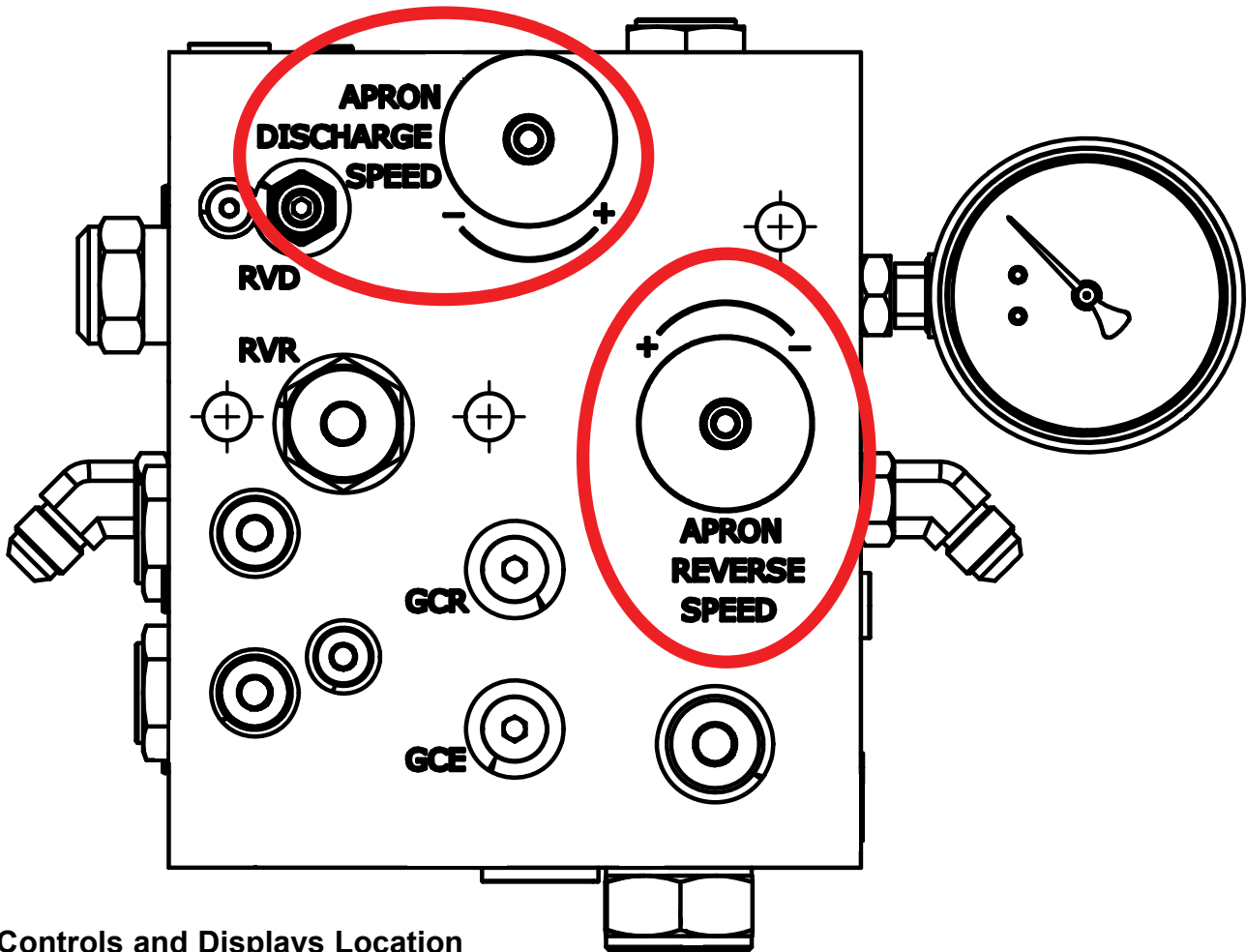

Controls and Displays Location

The manifold pictured above can be found under the shield centered in the front of the unit shown below.

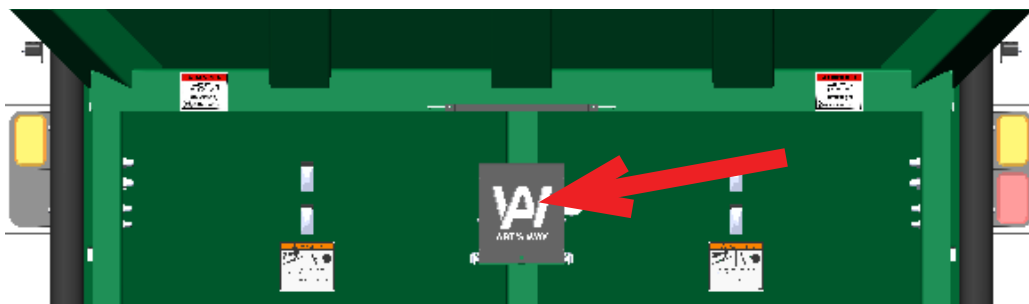

Controls and Displays Explanation of Symbols

The knob labeled “APRON DISCHARGE SPEED” can be used to enable/disable and meter the hydraulic flow to the apron chain motors to limit the unload speed. The knob can be turned counterclockwise “+” to speed up and clockwise “-” to slow down the amount of flow. The locking knob behind the main knob can be set to lock any position. It is recommended the knob be turned counterclockwise to the maximum “+” and locked in place and flow/speed be controlled by the tractor hydraulic flow output setting.

The knob labeled “APRON REVERSE SPEED” can be used to enable/disable and to meter the hydraulic flow to the apron chain motors to limit the reverse speed. The knob can be turned counterclockwise “+” to speed up and clockwise “-” to slow down the amount of flow. The locking knob behind the main knob can be set to lock any position. It is recommended the knob be turned clockwise to the minimum “-” and locked in place to disable and prevent accidental apron chain reversal.

Operating Instructions

WARNING

Before operation, be sure no one is near the spreader and the discharge area is clear of objects or persons that could be harmed if material is discharged. Make sure that all parts have stopped moving and the ignition key is off and removed before making any adjustments, maintenance, or repairs.

Pre-Start Instructions

Verify that the “APRON REVERSE SPEED” knob on the spreader manifold is turned all the way to the “-”/clockwise position to prevent the apron chain from being ran in the reverse direction accidentally. It is recommended to run through the functions before the spreader is loaded for 5 minutes to check components, familiarize yourself, and dial in desired speeds.

CAUTION

Never attempt to run the apron chain in reverse with a full load, as this could cause damage to the chain or driving components. The “APRON REVERSE SPEED” knob on the manifold should be locked in the max “-”/clockwise position unless there is a need to clear the beaters and should be returned to the max “-”/clockwise position as soon as beaters are cleared.

Hitch the manure spreader to the tractor. Then attach the PTO and hydraulic remotes in color coded pairs. Ensure the PTO and hydraulic remotes are properly locked in. Do not load the unit behind the slop gate.

Starting, Stopping, and Shutdown

Make sure to do the following sequence in the order it is described. With the vehicle stopped and engine throttled down, slowly engage the PTO and supply 1000 RPM to the beaters.

Raise the slop gate to your desired height. This should be based on the density of the manure being spread. For cattle manure a fully open gate is recommended where with poultry litter a lower gate height may be used. Use the hydraulic control connected to the "GREEN" hose ends to raise and lower the slop gate. 6 GPM flow is needed to run the slop gate at max speed, avoid exceeding this rate.

Engage the apron chain, in the forward discharge direction, using the hydraulic control connected to the "BLACK" hose ends. NEVER ENGAGE THE APRON CHAIN WITH THE SLOP GATE IN THE FULLY CLOSED POSITION AND/OR WITHOUT THE BEATERS SPINNING. 16 GPM hydraulic flow is needed to run the apron chain at max speed, avoid exceeding this rate.

Once material starts to contact the beaters, start tractor in motion and set it to a speed that allows for preferred spreading density.

After all the manure is spread, turn off the apron chain, close the slop gate, and shut down the PTO/beaters. The beaters are equipped with an overrunning clutch to slowly spin down after the PTO is turned off to decrease shock load on the beaters. In an emergency situation turn off the offending feature and/or put the tractor in park and turn off the tractor completely.

Functions and Adjustments

Your manifold is equipped with a pressure relief valve to protect the system which is set to 2,250 psi. If your gauge is reading 2,250 psi or close to it then it is possible the system is going over relief. Check the pressure gauge on the manifold while supplying hydraulic power to the apron chains.

The pressure relief valve setting should never be increased past 2,250 psi and doing so will void any and all applicable warranty. The pressure relief valve setting can be decreased to the minimum amount of psi required to provide additional protection for different models of manure spreaders.

Clearing Blockages and Cleaning

If the apron chain fails to move when hydraulic power is supplied from the tractor first fully shut down everything including the tractor itself and inspect the unit for binds, breakages, hydraulic leaks, or anything out of the ordinary.

If needed the apron chain can be reversed to help clear the beaters. Turn the "APRON REVERSE SPEED" knob "+"/counterclockwise in small increments to slowly enable the ability to reverse the apron chain. Reduce and reverse the flow to the remote from the tractor to start slowly reversing the chain. Turn and lock the "APRON REVERSE SPEED" knob in the max "-"/clockwise position once the load on the beaters has been backed off. Do not attempt to reverse the apron chain if the box is fully loaded. Turn off the tractor and unit then fix any issues before continuing.



Be cautious of the potential for stored energy when clearing blockages. Parts may move quickly and or violently when blockages are cleared.

Troubleshooting

If the apron chain is not moving and the gauge on the manifold is reading close to 2,250 psi and there are no blockages or broken components the load on the chain must be lightened. Remove manure until the load is lightened enough to move.

If a hydraulic component is abnormally hot after running a load ensure that the unit is not going over relief, the tractor is not supplying over 16 GPM to the apron chains and 6 GPM to the slop gate, and or the "APRON DISCHARGE SPEED" knob is not set too low.

If the beaters stop spinning with the PTO engaged, first disengage the PTO and turn off the tractor, then check all shear points in the driveline. Replace shear bolt or slip clutch pads as necessary with Art's Way approved components.

For additional troubleshooting contact your nearest dealer or the Art's Way customer service center.

--ROUTINE MAINTENANCE AND ADJUSTMENTS--**Maintenance Schedules**

Remember always stop the unit, shut off the vehicle, and remove key before servicing, repairing, cleaning, or adjusting.

Lubrication is extremely important to the longevity of your X900. Ensure the unit is properly lubricated before first use and then according to the schedule below thereafter.

DESCRIPTION	INTERVAL	LUBRICANT
APRON BEARINGS	15-20 HOURS	GREASE
APRON GEAR CASE	ANNUALLY	EP90 GEAR LUBE
APRON CHAIN	WHEN PARKED	30WT OIL
BEATER GEAR CASE	ANNUALLY	EP90 GEAR LUBE
UNIVERSAL JOINTS	15-20 HOURS	GREASE
AXLE HUBS	BI-ANNUALLY	GREASE
PTO SHAFTS	15-20	GREASE
SLIP CLUTCH	BI-ANNUALLY	GREASE
CAST FLANGE BEARINGS	15-20 HOURS	GREASE
PILLOW BLOCK BEARINGS	15-20 HOURS	GREASE
SLOP GATE PIVOT POINT	15-20 HOURS	GREASE

Check oil level in beater and apron gearboxes before every day of use, add when needed to maintain proper level in sight plugs. It is recommended to drain and change oil in the gearboxes annually.

Check beaters before everyday of use. Inspect all beater teeth, knives, scoops, and hardware for damage and/or signs of loosening. Repair, replace, and/or re-torque where necessary. See the "SPECIFICATIONS" page for torque values.

Periodically remove any entanglements from the beaters to limit potential damage and to maintain optimal performance of the beaters.

After a few hours of initial operation, check all nuts, bolts, and set screws to be sure they are tight and secure. Thereafter thoroughly check all hardware each month or after 25 loads of use, torque to proper setting (see the "SPECIFICATIONS" page for torque values) or replace if necessary.

Periodically check all bearings and bushings for wear and replace if necessary.

Inspect apron chains for wear, proper alignment, and tension; according to the adjustment guidelines shown in the "Maintenance Procedures" section before every day of operation. Be sure to keep proper tension on apron chains as shown in the "Maintenance Procedures" section as frequently as possible.

Slop gate plastic slides should be replaced if plastic wears far enough that the rivets are no longer recessed.

Maintenance Procedures

Remember always stop the unit, shut off the vehicle, and remove key before servicing, repairing, cleaning, or adjusting.

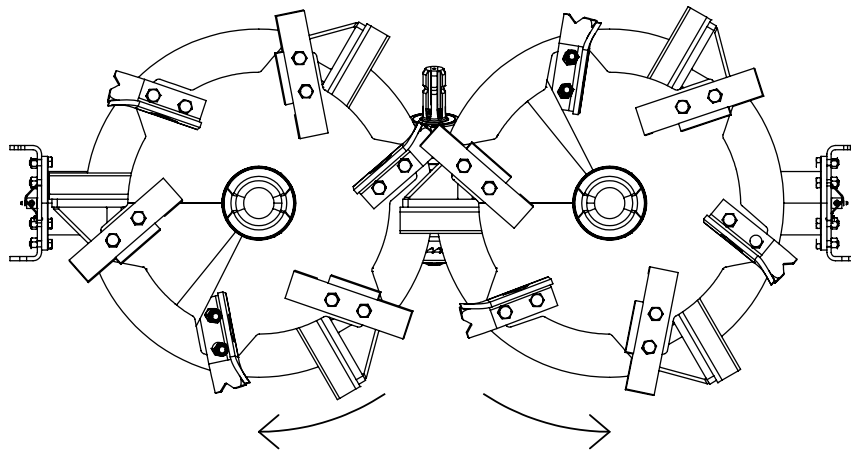

Beater teeth, knives, and/or scoops should be replaced in a manner that will keep the corresponding beaters as balanced as possible.

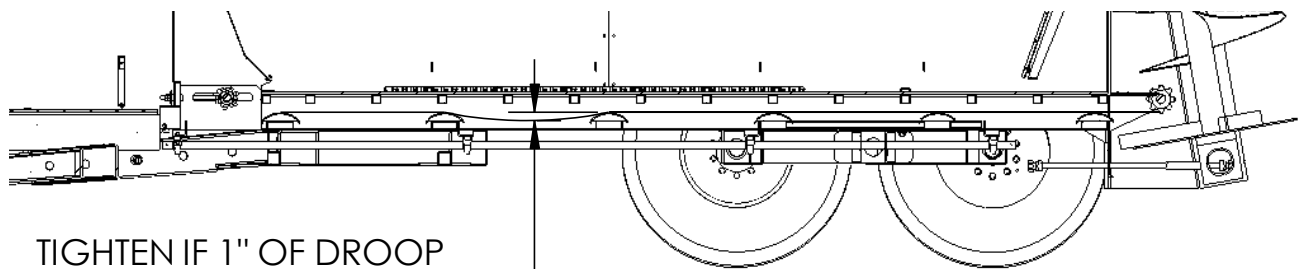

TIGHTEN IF 1" OF DROOP
OR MORE BETWEEN GUIDES

The (4) apron chain tensioner bolts are located in the front of the unit at each side of the (2) apron tensioner shafts. They should be adjusted evenly to help keep proper chain alignment. Measure from the front of the box weldment to the left and right extents of the tensioner shaft to ensure tension is being applied evenly. The apron tensioner bolts are double nutted to lock the position in place.

If an apron chain is loose and the tensioner bolts are maxed out, loosen the tensioner bolts completely, remove one link from each side of apron chain assembly, and readjust to tension as shown above.

Over tightening can cause premature failure of the chain and drive components. Apron chains are set tight from factory to account for initial chain stretch. If an apron chain is ran too loose with excessive slack; binding could occur and cause damage to the unit.

If you weld on this unit do not allow the currents to flow through the bearings, scale wires, load cells, or any other electronic equipment. Ground directly to the item being welded/ repaired. Be sure no bearings or gearboxes are in between welder and ground connection.

⚠ DANGER

If working on any hydraulic components use extreme caution as there could be stored hydraulic pressure in the system. Hydraulic repairs should be performed by a qualified service technician on an empty machine.

If a hydraulic component is repaired or replaced the effected circuit should be bled of all air before attempting to use the equipment.

For example if a hydraulic cylinder is replaced that operates the slop gate; once all fittings are tight and the repair is ready to be tested; with the slop gate in the fully down (cylinders retracted) position disconnect the gate from both cylinders. Once the gate is no longer attached to either cylinder cycle the cylinders up and down fully a few times to ensure all air has been purged before retracting the cylinders and re-attaching them to the slop gate. Ensuring air is purged will help to ensure the cylinders extend and retract at the same rate and do not cause the slop gate to tilt/bind/become damaged.

Keep all hydraulic connections cleaned and free of debris. Even small particulates of dirt and debris can cause serious damage to any hydraulic system and it's components.

When performing wheel maintenance the following torque specs and procedures should be followed.

Lug nuts should be torqued to 400 ft-lbs.

Torque spindle nut to 75-85 ft-lbs while rotating the hub.

Loosen spindle nut and re-torque to 45-50 ft-lbs.

Loosen spindle nut no more than 30° max to align with cotter pin hole, if not already aligned.

Follow tire manufacturer's recommendation for tire pressures.

Maintenance Materials

Apron chain gearboxes should be filled with approx. 4 quarts of SAE 90 EP full synthetic or 75W-90 full synthetic gear oil each.

The beater gearbox should be filled with approx. 13-1/4 quarts of SAE 90 EP full synthetic or 75W-90 full synthetic gear oil.

Adjustments

Slop gate should be fully open when spreading cattle manure. With poultry manure the slop gate can be set lower for better performance. Never attempt to run the apron chain with the gate fully closed.

An optional kit is available to add cupped scoops to the bottom pans of the vertical beaters to increase performance spreading poultry manure.

Apron chain speed limit can be adjusted at the hydraulic manifold. See "Controls and Displays" section of this manual for more information.

Apron chain tension should be kept adjusted according to the specified tension in the section under "Maintenance Procedures".

Optional floatation tires can be purchased that offer lower load height and less soil compaction versus the standard tire option.

The spreader hitch should be adjusted so that the unit is as close to level as possible when hitched to the tractor without the front of the spreader box being lower than the rear.

For adjustments pertaining to optional scales or rate control refer to documents included with those systems.

Storage

Your manure spreader should be cleaned and lubricated before long term (seasonal) storage.

Remove drain plug bolts from the bottom wedges of the slop gate weldment arms to drain any possible accumulated water or other debris before and periodically during freezing weather conditions.

This machine includes a PTO storage bracket for when the machine is stored or is not hooked to a tractor.

--SPECIFICATIONS--

Follow the charts provided for general torque values.

For wheel/hub related torque settings refer to the section under "Maintenance Procedures".

SIZE	GRADE 5		GRADE 8	
	PLAIN TORQUE (K=.20)	ZINC TORQUE (K=.17)	PLAIN TORQUE (K=.20)	ZINC TORQUE (K=.17)
INCH POUNDS				
4-40	8	7	12	11
4-48	9	8	13	12
6-32	16	14	23	20
6-40	18	16	25	22
8-32	30	26	41	36
8-36	31	27	43	38
10-24	43	38	60	53
10-32	49	43	68	60
1/4"-20	96	86	144	126
1/4"-28	120	103	168	144
FOOT POUNDS				
5/16"-18	17	15	25	21
5/16"-24	19	16	27	23
3/8"-16	31	26	44	37
3/8"-24	35	30	49	42
7/16"-14	49	42	70	59
7/16"-20	55	47	78	66
1/2"-13	75	64	106	90
1/2"-20	85	72	120	102
9/16"-12	109	92	154	130
9/16"-18	121	103	171	146
5/8"-11	150	128	212	180
5/8"-18	170	144	240	204
3/4"-10	267	227	376	320
3/4"-16	297	253	420	357
7/8"-9	429	365	606	515
7/8"-14	474	403	669	568
1"-8	644	547	909	772
1"-12	722	614	1020	867
1-1/8"-7	800	700	1280	1120
1-1/8"-12	880	770	1440	1260
1-1/4"-7	1121	952	1817	1545
1-1/4"-12	1241	1055	2012	1710
1-3/8"-6	1460	1280	2380	2080
1-3/8"-12	1680	1470	2720	2380
1-1/2"-6	1950	1657	3162	2688
1-1/2"-12	2194	1865	3557	3024
TORQUE VALUES AQUIRED FROM SABRE INDUSTRIAL SUPPLIES AND FASTENAL				

SIZE DIA-PITCH	GRADE 8.8		GRADE 10.9	
	PLAIN TORQUE (K=.20)	ZINC TORQUE (K=.17)	PLAIN TORQUE (K=.20)	ZINC TORQUE (K=.17)
FOOT POUNDS				
3-0.5	1.0	0.9	1.4	1.3
4-0.7	2.3	1.9	3.2	2.7
5-0.8	4.5	3.9	6.5	5.5
6-1.0	7.7	6.6	11.1	9.4
7-1.0	13.0	11.0	18.5	15.8
8-1.0	19.0	18.0	28.0	25.0
8-1.25	18.8	16.0	26.9	22.9
10-1.0	39.0	42.8	32.5	42.3
10-1.25	38.0	36.0	53.0	50.0
10-1.5	37.2	31.6	53.2	45.2
12-1.25	70.0	64.0	99.0	92.0
12-1.5	62.3	69.0	56.8	84.1
12-1.75	64.9	55.1	92.8	78.9
14-1.5	110	103	154	143
14-2.0	104	88	148	126
16-1.5	165	154	232	217
16-2.0	161	137	230	196
18-2.5	222	189	318	270
20-1.5	339	313	472	442
20-2.5	314	267	449	382
22-2.5	428	364	613	521
24-2.0	575	531	811	737
24-3.0	543	461	777	660
27-3.0	796	676	1139	968
30-3.5	1079	917	1544	1312
33-3.5	1468	1248	2101	1786
36-4.0	1886	1603	2699	2294
TORQUE VALUES AQUIRED FROM FASTENER MART, FASTENAL, & IMPERIAL SUPPLIES				

--AUXILIARY INFORMATION--

General

The following may or may not apply to your specific manure spreader based on selected options and features at purchase.

Reception

If the spreader is delivered with running gear disassembled (on a flatbed) or If the spreader is delivered with running gear assembled (towed) and has the floatation tire option installed please take note of the tread direction.

Floatation tires may be installed with “forward pointing” tread direction to decrease floatation properties when in transit to distant destinations. Tires should be installed with “backward pointing” tread direction before unit is delivered to end-user to increase floatation performance in field.



Assembly and Initial Setup

Manure spreaders are often shipped either fully assembled or sans wheels and PTO attached. Attach loose components per torque guidelines included with this manual. Use the included “Illustrated Parts List” section of this manual as an assembly guide.

It is recommended to read and follow this manual before attempting to operate the manure spreader.

Transportation

Collapse the PTO and use the supplied worm gear clamp to secure the PTO to the storage bracket if the spreader is to be transported with the PTO not connected to the tractor.

Secure the hydraulic lines so that they do not become damaged/dirty during transport.

Hitch pivot lockers may be included with your unit (circled below). These lockers either prevent or limit hitch swivel based on their installation location. They are not intended to limit hitch swivel/rotation while towing the unit, but are intended to limit hitch rotation while hitching and unhitching the unit if so desired. Once the unit is hitched to the towing vehicle the pivot lockers should be moved to the lowermost position as shown below or removed.

The hitch itself should be positioned so that the spreader is as close to level as possible on flat ground. This positioning is dependant on the drawbar height of the towing equipment.



Warranty

For full warranty information please visit <https://artsway.com/resources/warranty/> for the most up-to-date warranty policy and information on filing a claim.

To be eligible for warranty, each new product must be registered with Art's Way Mfg. within 30 days of delivery to the original purchaser.

Warranty claims must be submitted no later than 30 days from the date that the defect or improper workmanship was, or should have been, diagnosed/repared. If defective date is less than 30 days away from end of warranty period, proof must be submitted with date of work completed.

Accessories and Attachments

Optional accessories and/or attachments are available for this unit such as, but not limited to, scales and litter scoops.

For information on these please refer to documentation included with them and/or the "Illustrated Parts List" section of this manual.

**THIS PAGE
LEFT
INTENTIONALLY
BLANK**



ILLUSTRATED PARTS LIST

ART'S WAY

HYDRAULICS ASSEMBLY

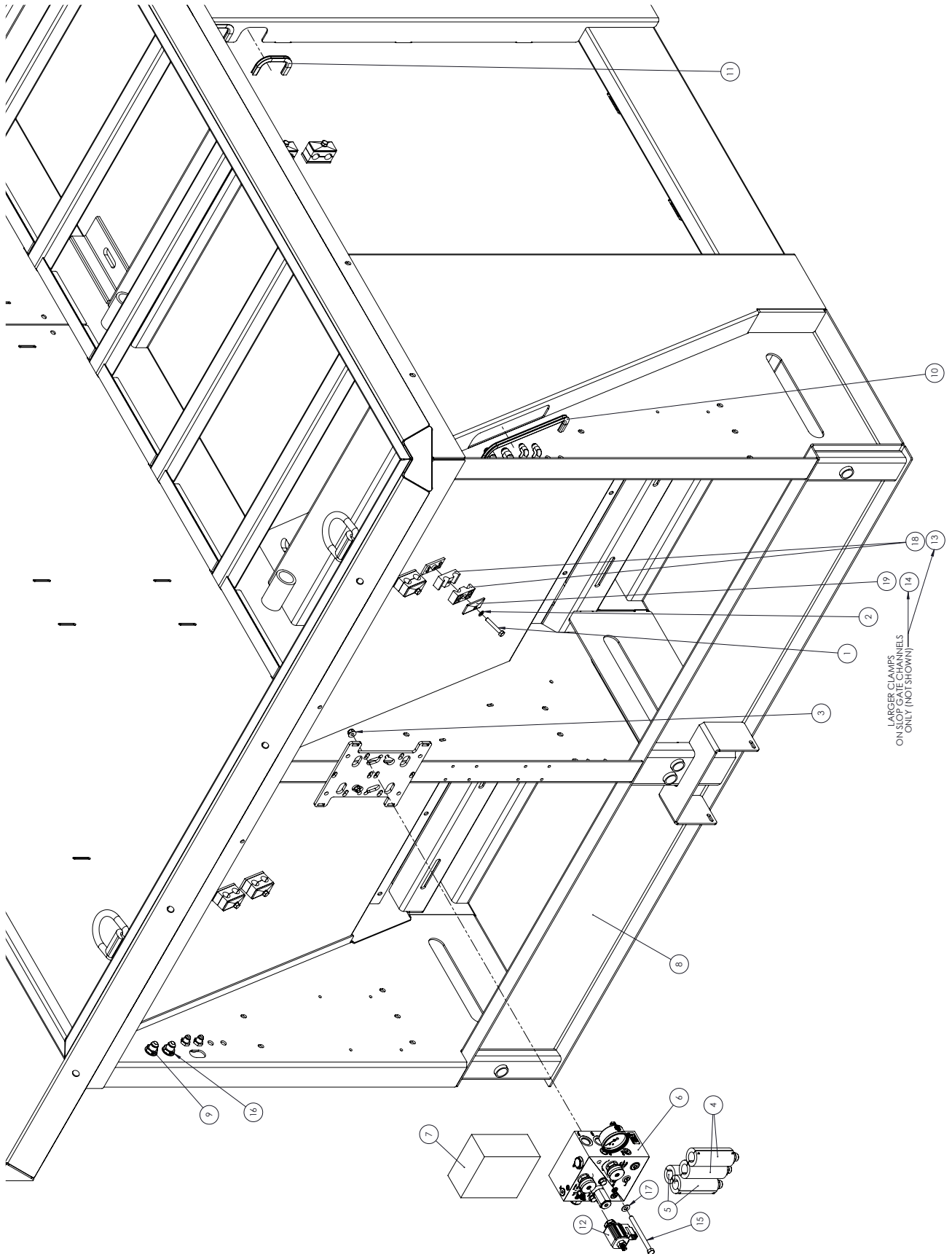

ITEM NO.	PART NUMBER	DESCRIPTION	QTY.
1	017120	BOLT, HHCS 5/16-18 X 2 G	28
2	023620	WASHER, LOCK 5/16	28
3	600120	NUT, HFH NYLOC 3/8-16	3
4	690610	FITTING, HYD GRIPS BLACK	1
5	690611	FITTING, HYD GRIPS GREEN	1
6	690880	BLOCK, HYD F13890A1	1
7	690946	X900 HYDRAULIC KIT	1
8	690991	MAIN BOX WELDMENT	1
9	691085	SPACER, NYLON	4
10	691094	EDGE PROTECTOR, HOSES	2
11	691095	EDGE PROTECTOR, HOSES	44
12	691800 *	VALVE, PWM RAVEN	1
13	710811	CLAMP, HALF PLASTIC	8
14	710812	CLAMP, COVER PLATE	4
15	991160	BOLT, HHCS 3/8-16 X 4-1/2"	3
16	E126057	WASHER, FLAT 3/4"	8
17	I120394	WASHER, FLAT 3/8 SAE	3
18	MP17.01144	SECTION, HOSE CLAMP	48
19	U51800177	TOP CAP, HOSE CLAMP	24
PART NUMBERS WITH * AFTER ARE ON SCALED UNITS ONLY			

MANIFOLD ASSEMBLY

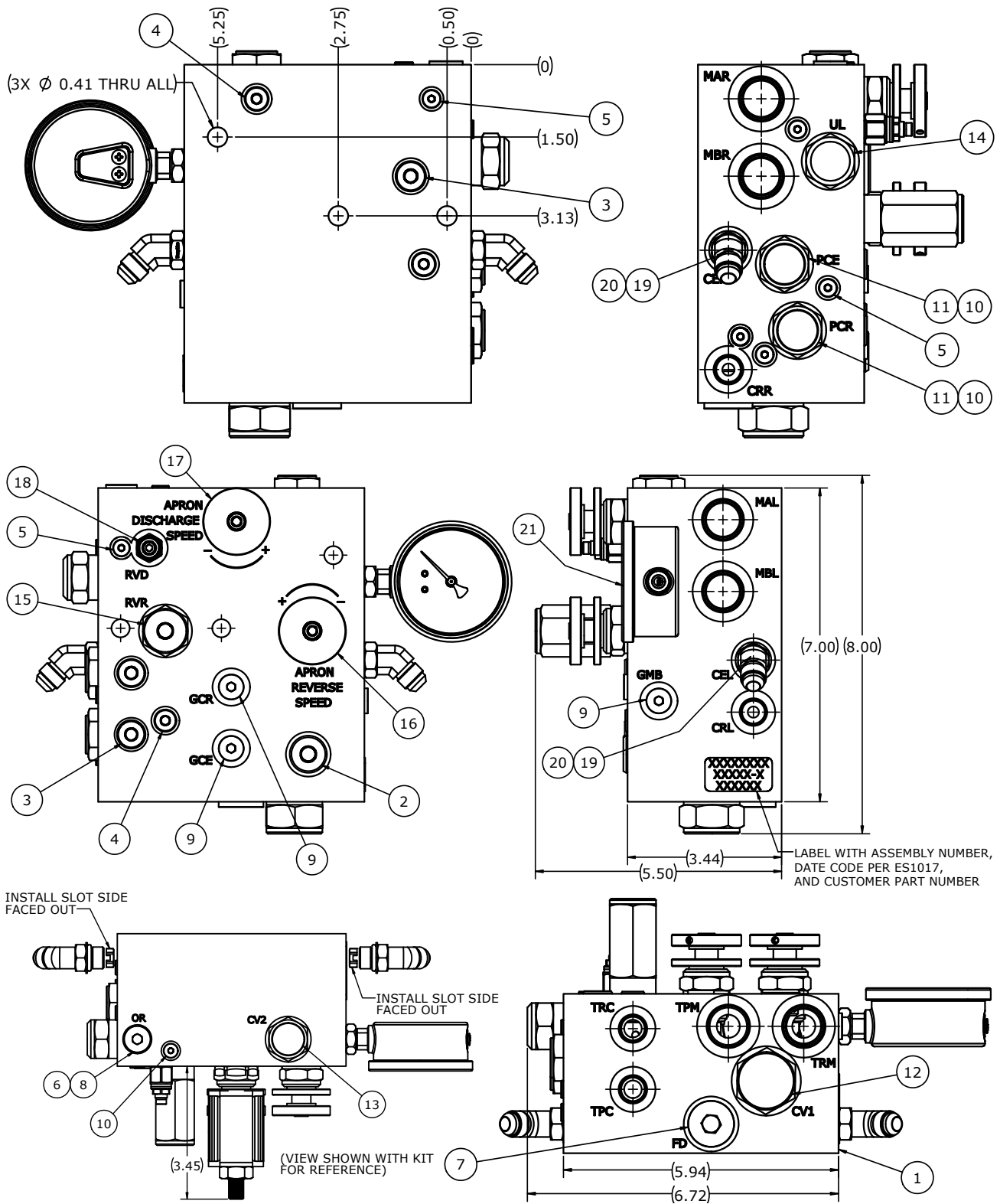

ITEM NO.	PART NUMBER	DESCRIPTION	QTY.
1	N/A	BODY, X-SERIES MANURE SPREADER MFLD	1
2	691250	SAE-8 PLUG ZERO-LEAK	1
3	710834	SAE-6 PLUG, ZERO-LEAK	3
4	691251	SAE-4 PLUG, ZERO-LEAK	3
5	691252	SAE-2 PLUG, ZERO-LEAK	7
6	710820	ORIFICE PLUG 5/16-24 0.031	1
7	274425	PLUG SAE -10 HOLLOW HEX	1
8	601112	PLUG SAE -06 HOLLOW HEX	1
9	488970P	PLUG SAE -04 HOLLOW HEX	3
10	691253	PILOT PISTON -10 SINGLE W/OUT SEALS	2
11	691254	CART, CHECK VALVE 35 PSI	2
12	646208	CART, CHECK VALVE 5 PSI	1
13	691255	CART. CHECK VALVE REV 50 PSI	1
14	691256	CART, LOGIC SPOOL N/C L/S ELEMENT	1
15	691257	CART, RELIEF VALVE DIFF AREA 1200 PSI	1
16	691258	CART, NEEDLE VALVE, FINE ADJ.	1
17	691259	CART, NEEDLE VALVE	1
	691800 *	PWM VALVE KIT (NEEDED RAVEN UNITS ONLY)	
18	691260	CART, RELIEF VALVE 100-3000 PSI	1
19	691261	SAE-6, 0.120 ORIFICE CHECK	2
20	634103	FITTING 45 DEG -6 MJIC / -6 MORB	2
21	646200	GAUGE - 2.5" LIQUID, STEM MOUNT, SAE -4	1
PART NUMBERS WITH * AFTER ARE ON SCALED UNITS ONLY			

HYDRAULICS DIAGRAM

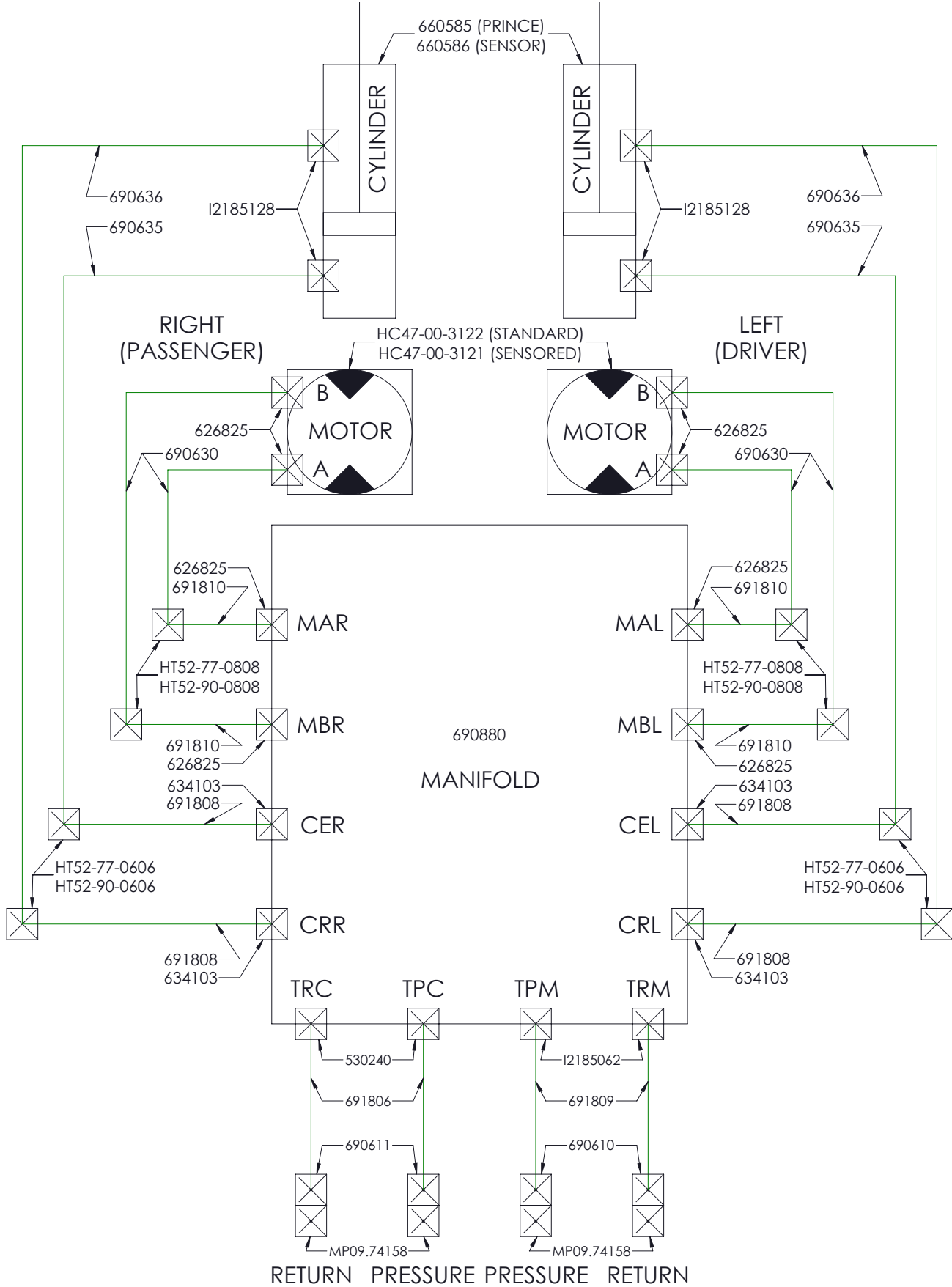

IDENTIFICATION KEY	
LABEL	MEANING
OR	ORIFICE
CV1	CHECK VALVE 1
CV2	CHECK VALVE 2
MAR	MOTOR "A" RIGHT
MBR	MOTOR "B" RIGHT
MAL	MOTOR "A" LEFT
MBL	MOTOR "B" LEFT
CRR	CYLINDER RETRACT RIGHT
CER	CYLINDER EXTEND RIGHT
CRL	CYLINDER RETRACT LEFT
CEL	CYLINDER EXTEND LEFT
PCR	PILOT CHECK RETRACT
PCE	PILOT CHECK EXTEND
GCE	GAUGE CYLINDER EXTEND
GCR	GAUGE CYLINDER RETRACT
GMA	GAUGE MOTOR "A"
GMB	GAUGE MOTOR "B"
TRC	TRACTOR RETURN CYLINDER
TPC	TRACTOR PRESSURE CYLINDER
TPM	TRACTOR PRESSURE MOTOR
TRM	TRACTOR RETURN MOTOR
UL	UNLOADER
RVR	RELIEF VALVE RETRACT
RVD	RELIEF VALVE DISCHARGE
FD	FLOW DIVIDER

RUNNING GEAR ASSEMBLY

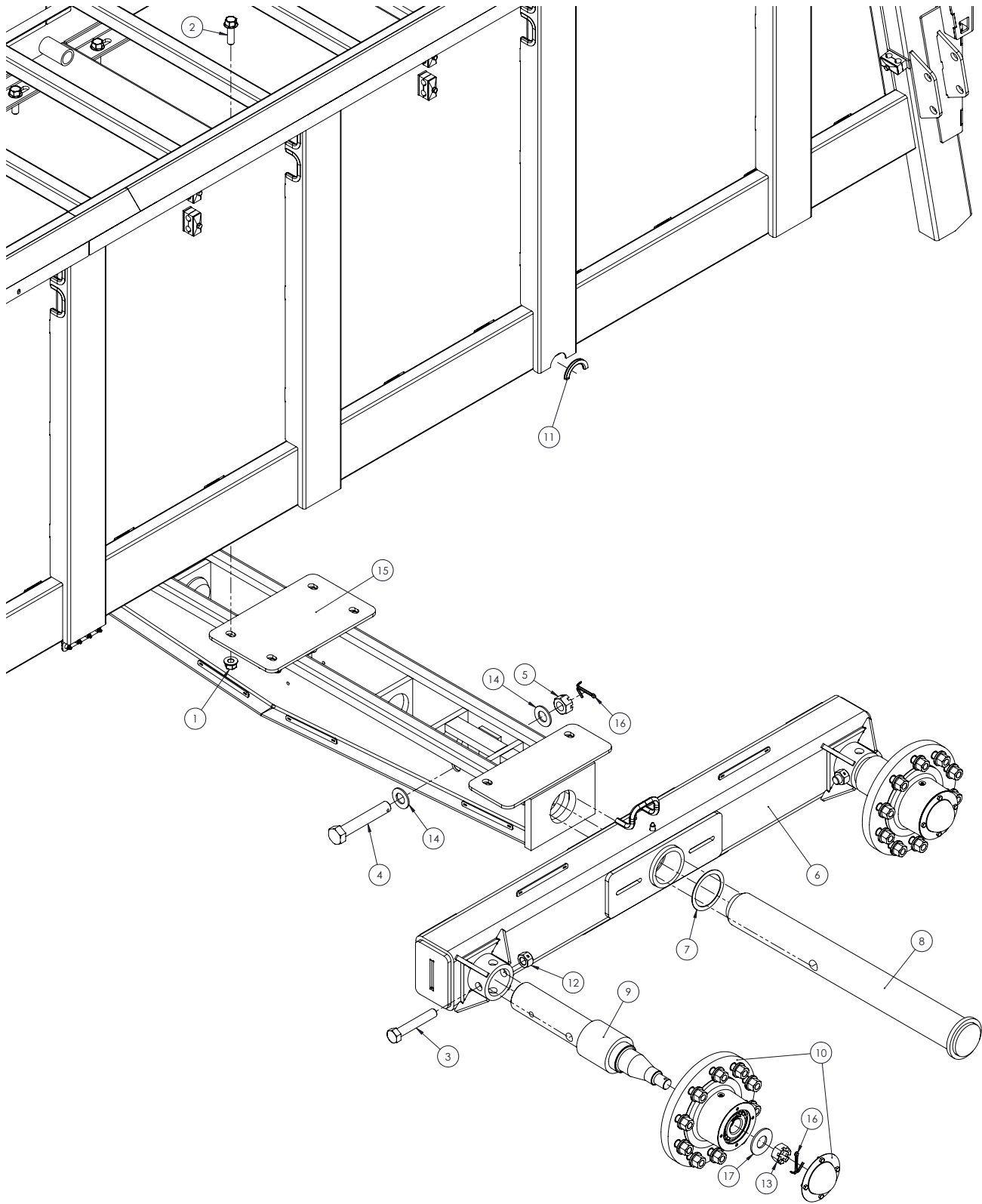

<u>ITEM NO.</u>	<u>PART NUMBER</u>	<u>DESCRIPTION</u>	<u>QTY.</u>
1	600160	NUT, HFH TOPLOCK 3/4-10	8
2	600430	BOLT, HFH 3/4-10 X 2-1/2"	8
3	600490	BOLT, HHCS 1-8 X 6"	4
4	614280	BOLT, HHCS 1-1/4-7 X 7.5"	2
5	614290	NUT, SLOTTED 1-1/4-7	2
6	638610	TANDEM WLDT, ROCKER	2
7	690675	SHIM, TANDEM ROCKER	2
8	690915	PIVOT PIN WELDMENT	2
9	691045 *	WEIGH SPINDLE	4
	691040	STANDARD SPINDLE	
10	691050	HUB ASSY, 10 BOLT/11.25"	4
11	691096 *	EDGE PROTECTOR, WIRES	2
12	990510	NUT, LOCK 2-WAY 1-8	4
13	E552023	NUT, SLOTTED 1-1/4-12	4
14	E829022	WASHER, FLAT 1-1/4" SAE	4
15	H160007	AXLE (TANDEM)	1
16	MP906827	.25"X 3" COTTER PIN	6
17	R61502	WASHER,FLAT 1-3/8" STD	4
PART NUMBERS WITH * AFTER ARE ON SCALED UNITS ONLY			

HUB ASSEMBLY

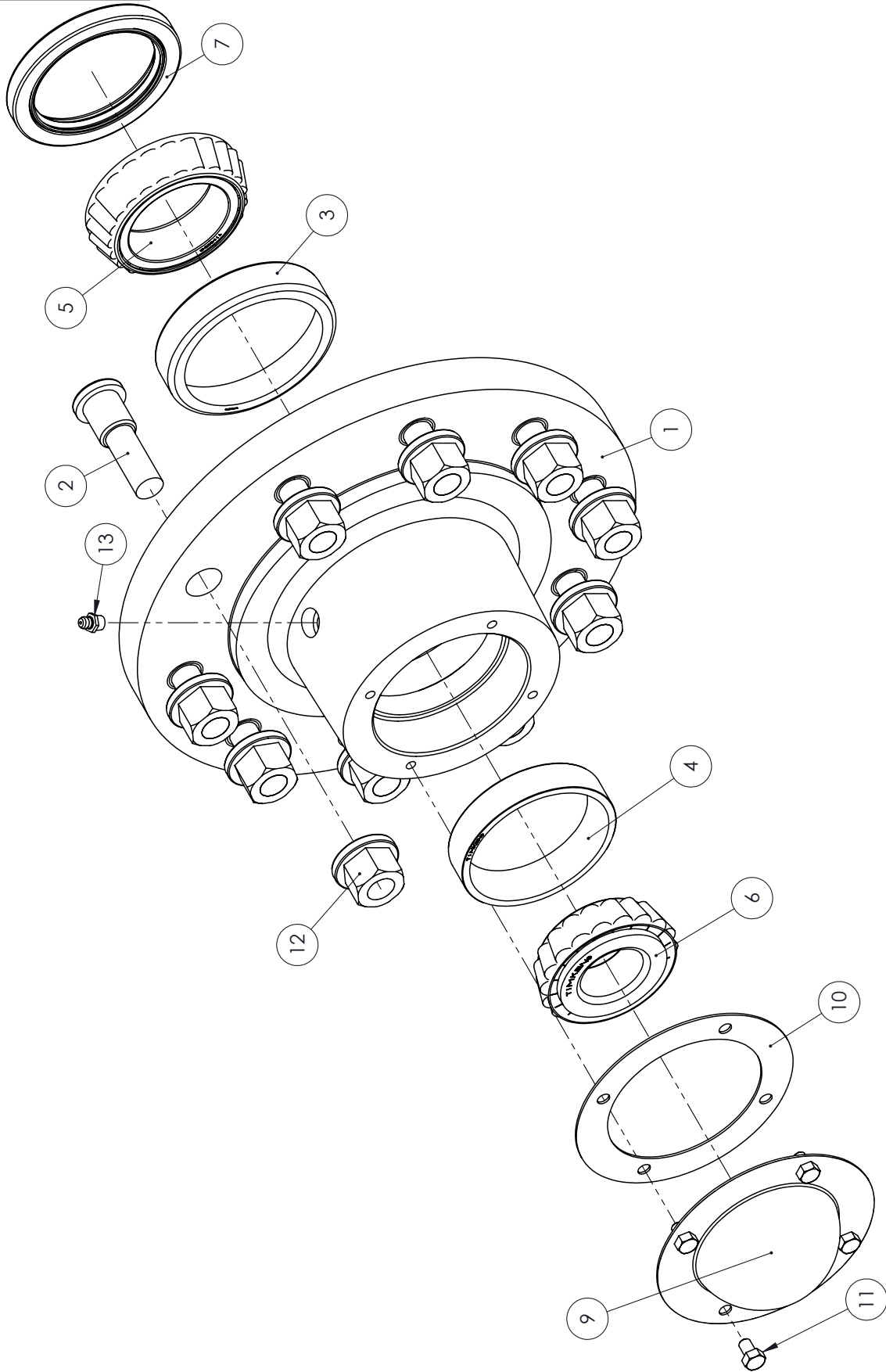

ITEM NO.	PART NUMBER	DESCRIPTION	QTY.
1	691051	HUB CAST, GROVE	1
2	691052	STUD, HUB 3/4-16 X 3" G8	10
3	691053	RACE, INNER BEARING	1
4	691054	RACE, OUTER BEARING	1
5	691055	CONE, INNER BEARING NTN	1
6	691056	CONE, OUTER BEARING NTN	1
7	691057	SEAL, HUB	1
8	691058	HUB CAP, GASKET, & BOLTS	1
9	691092	HUB CAP	1
10	691091	GASKET, HUB CAP	1
11	136470	BOLT, HHCS 5/16-18X5/8 GR5 ZN	4
12	691059	LUGNUT, S-FLANGE 3/4-16	10
13	JJD7798	ZERK, 1/8-27 NPT	1

TONGUE ASSEMBLY

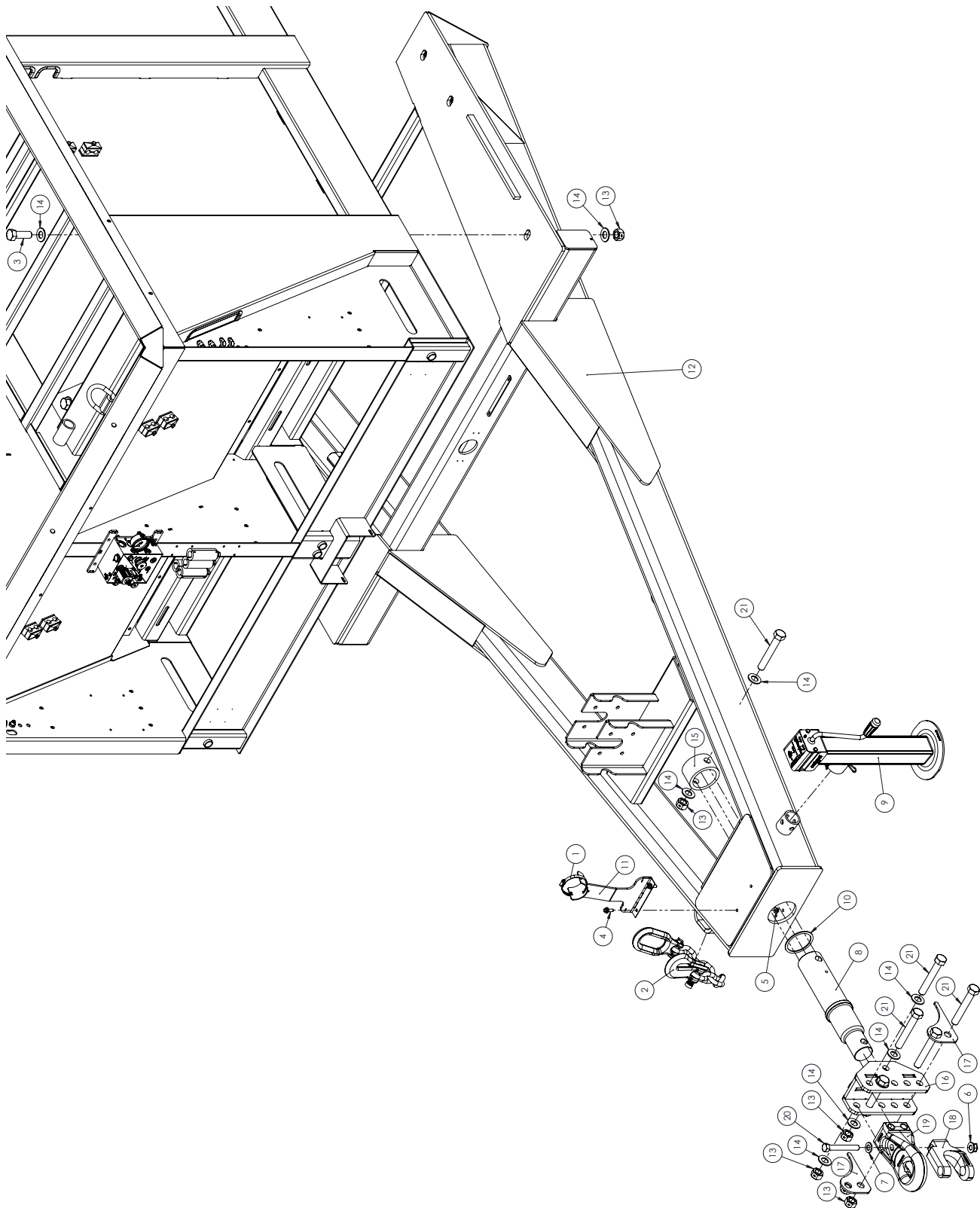

ITEM NO.	PART NUMBER	DESCRIPTION	QTY.
1	455160	HOSE CLAMP	1
2	472910	CHAIN ASSY, SAFETY	1
3	497590	BOLT, HHCS 1-8 X 3 GR8	6
4	600050	BOLT, HFH 3/8-16 X 1.00"	2
5	600120	NUT, HFH NYLOC 3/8-16	2
6	600160	NUT, HFH TOPLOCK 3/4-10	1
7	600330	WASHER, FLAT 3/4"	1
8	619840 *	LOAD CELL, HITCH	1
	H160075	STANDARD SHAFT, HITCH	
9	630900	JACK, NICKEL PLATED	1
10	691038 *	SPACER, TONGUE WEIGH BAR	1
	H160076	SPACER, STANDARD SHAFT	
11	691150	PTO SADDLE REST X900	1
12	692790	TONGUE WLDT, X900	1
13	990510	NUT, LOCK 2-WAY 1-8	12
14	1107389	WASHER, FLAT 1 SAE	20
15	H160077	SWIVEL HITCH STOP	1
16	H160081	X-SERIES, HITCH RECEIVER	1
17	H160081-05	HITCH SWIVEL STOP	2
18	HH76-02-8199	HITCH, CLEVIS	1
19	HH76-02-8238	HITCH, CAT4 AUSTEMPERED	1
20	I4261288	HBOLT 0.7500-10X5.5 GR8 ZN	1
21	J08H4722	BOLT, HHCS 1-8 X 6 1/2 GR8 ZN	6
PART NUMBERS WITH * AFTER ARE ON SCALED UNITS ONLY			

DRIVELINE ASSEMBLY

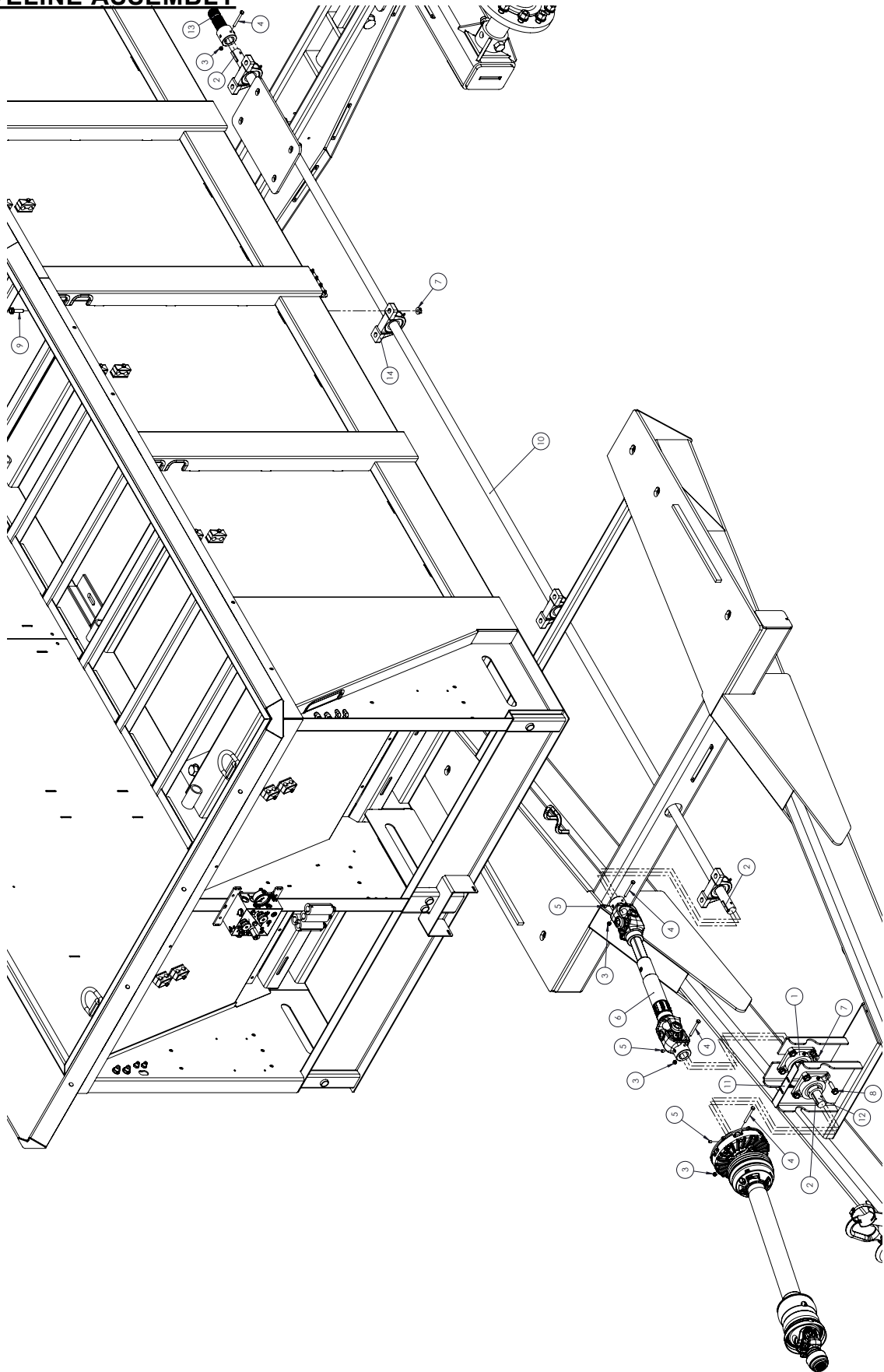

<u>ITEM NO.</u>	<u>PART NUMBER</u>	<u>DESCRIPTION</u>	<u>QTY.</u>
1	010560	BEARING, 1-1/2"	2
2	021530	KEY, SQUARE 3/8 X 2	4
3	025670	NUT, LOCK 5/16-18	4
4	160230	BOLT, HHCS 5/16-18 X 3 GR5	4
5	218660	SCREW, HSSS 3/8-16 X 3/8	3
6	598080	TELESCOPING SHAFT, 44R	1
7	600140	NUT, HFH NYLOC 1/2-13	16
8	600230	BOLT, HFH 1/2-13	8
9	600240	BOLT, HFH 1/2-13 X 2.00"	8
10	H160012	DRIVE SHAFT	1
11	H160025-04	SUPPORT, PTO SHIELD	1
12	H160028	PTO DRIVE SHAFT	1
13	H200186	PUMP ADAPTER	1
14	HK08-55-1027	BEARING, PILLOW BLOCK 1-1/2"	4
LINE ITEM	H160105	PTO, 1-3/8" X 21SPL 1000 RPM CV, CLUTCH, & OVERRUN	N/A
	H160106	PTO, 1-3/4" X 20SPL 1000 RPM CV, CLUTCH, & OVERRUN	

SHAFT ASSEMBLY (598080)

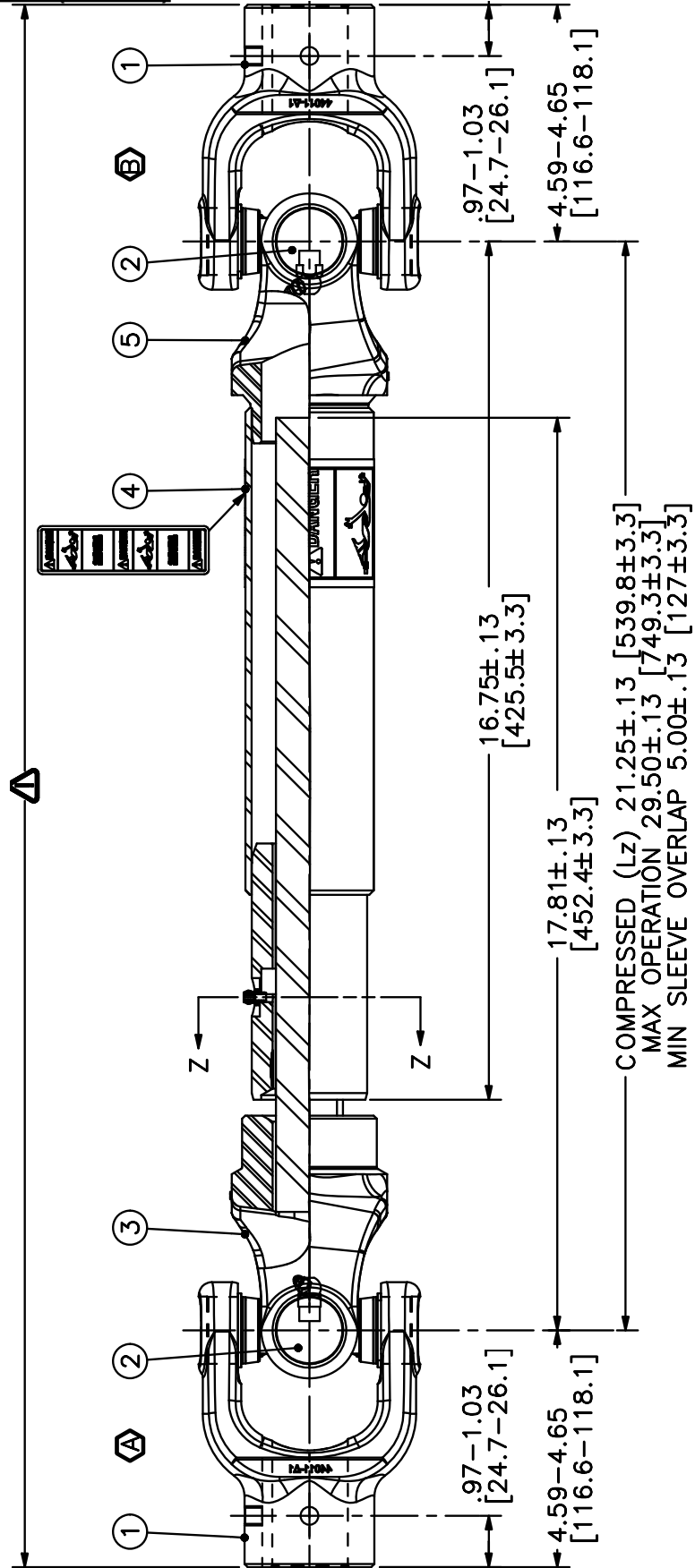

ITEM NO.	PART NUMBER	DESCRIPTION	QTY.
A	H95-26778	JOINT & SHAFT HALF ASM.	1
B	H94-26778	JOINT & TUBE HALF ASM.	1
1	H44030-1000	YOKE	2
2	H03-10089	44R CROSS KIT	2
3	H99-26778	YOKE & SHAFT (1.31 SQUARE)	1
4	H13-10022	SAFETY SIGN	1
5	H98-26778	YOKE, TUBE, & SLIP SLEEVE	1

ITEM NO.	PART NUMBER	DESCRIPTION	QTY.
A	H93-25415	JOINT & SHAFT HALF ASM. W/GUARD	1
B	H95-25415	JOINT & SHAFT HALF ASM.	1
C	H92-25415	JOINT & TUBE HALF ASM. W/GUARD	1
D	H94-25415	JOINT & TUBE HALF ASM.	1
1	H26-15120	SSL/AUTO-LOK REPAIR KIT	1
2	H86810-1016	WWCV AUTO-LOK YOKE ASM.	1
3	H03-15436	AB6/AW22/CAT 4 80-EBL CROSS KIT	2
4	H26-15159	WWCV CENTER HOUSING	1
5	H99-25415	WWCV YOKE & SHAFT (1.31-20 SPINE)	1
6	H19-15126	GUARD REPAIR KIT	2
7	H13-10021	SAFETY SIGN	1
8	H97-25415	OUTER GUARD	1
9	H96-25415	INNER GUARD	1
10	H13-10022	SAFETY SIGN	1
11	H98-25415	YOKE, TUBE, & SLIP SLEEVE	1
12	H03-15287	35EBL CROSS KIT	1
13	H38-15088	FRICTION CLUTCH ASM.	1

SHAFT ASSEMBLY (H160106) (20 SPLINE)

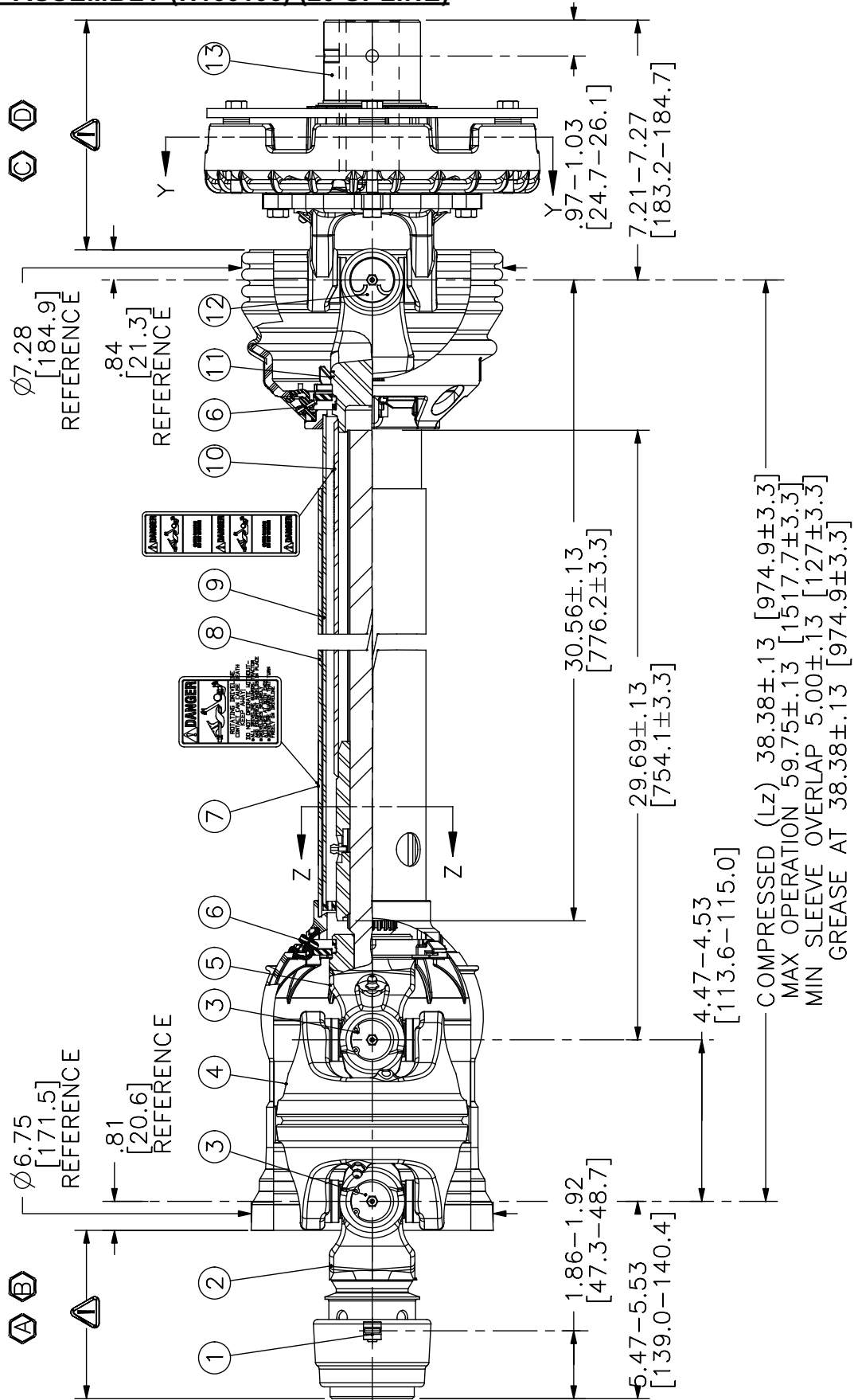

ITEM NO.	PART NUMBER	DESCRIPTION	QTY.
A	H93-26285	JOINT & SHAFT HALF ASM. W/GUARD	1
B	H95-26285	JOINT & SHAFT HALF ASM.	1
C	H92-25415	JOINT & TUBE HALF ASM. W/GUARD	1
D	H94-25415	JOINT & TUBE HALF ASM.	1
1	H26-13387	SSL/AUTO-LOK REPAIR KIT	1
2	H86810-1038	WWCV AUTO-LOK YOKE ASM.	1
3	H03-15436	A86/AW22/CAT 4 80-EBL CROSS KIT	2
4	H26-15159	WWCV CENTER HOUSING	1
5	H99-25415	WWCV YOKE & SHAFT (1.31-20 SPINE)	1
6	H19-15126	GUARD REPAIR KIT	2
7	H13-10021	SAFETY SIGN	1
8	H97-25415	OUTER GUARD	1
9	H96-25415	INNER GUARD	1
10	H13-10022	SAFETY SIGN	1
11	H98-25415	YOKE. TUBE. & SLIP SLEEVE	1
12	H03-15287	35EBL CROSS KIT	1
13	H38-15088	FRICTION CLUTCH ASM.	1

GREASE ASSEMBLY

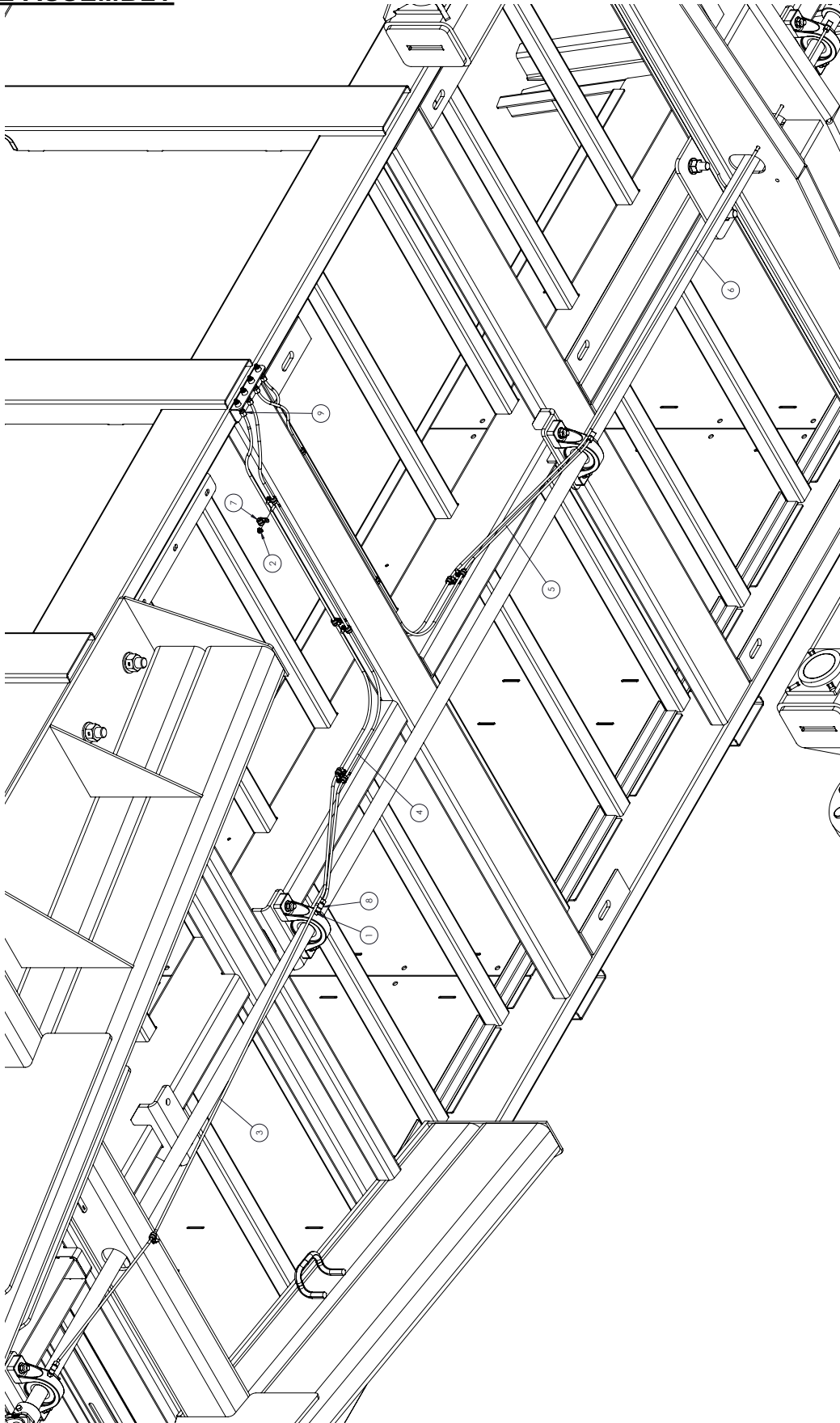

ITEM NO.	PART NUMBER	DESCRIPTION	QTY.
1	244270	ADAPTER, STRAIGHT	4
2	600100	NUT, HFH NYLOC 1/4-20	13
3	691220	HOSE, GREASE 1/4" X 131"	1
4	691221	HOSE, GREASE 1/4" X 68"	1
5	691222	HOSE, GREASE 1/4" X 68"	1
6	691223	HOSE, GREASE 1/4" X 124"	1
7	HJ14-00-0142	CLAMP, 1/4"	13
8	HT78-26-0204	CONNECTOR BRASS, 90, 1/8	4
9	HT78-47-0204	CONNECTOR, BRASS, STR., 1/8	4

MAIN FLOOR ASSEMBLY

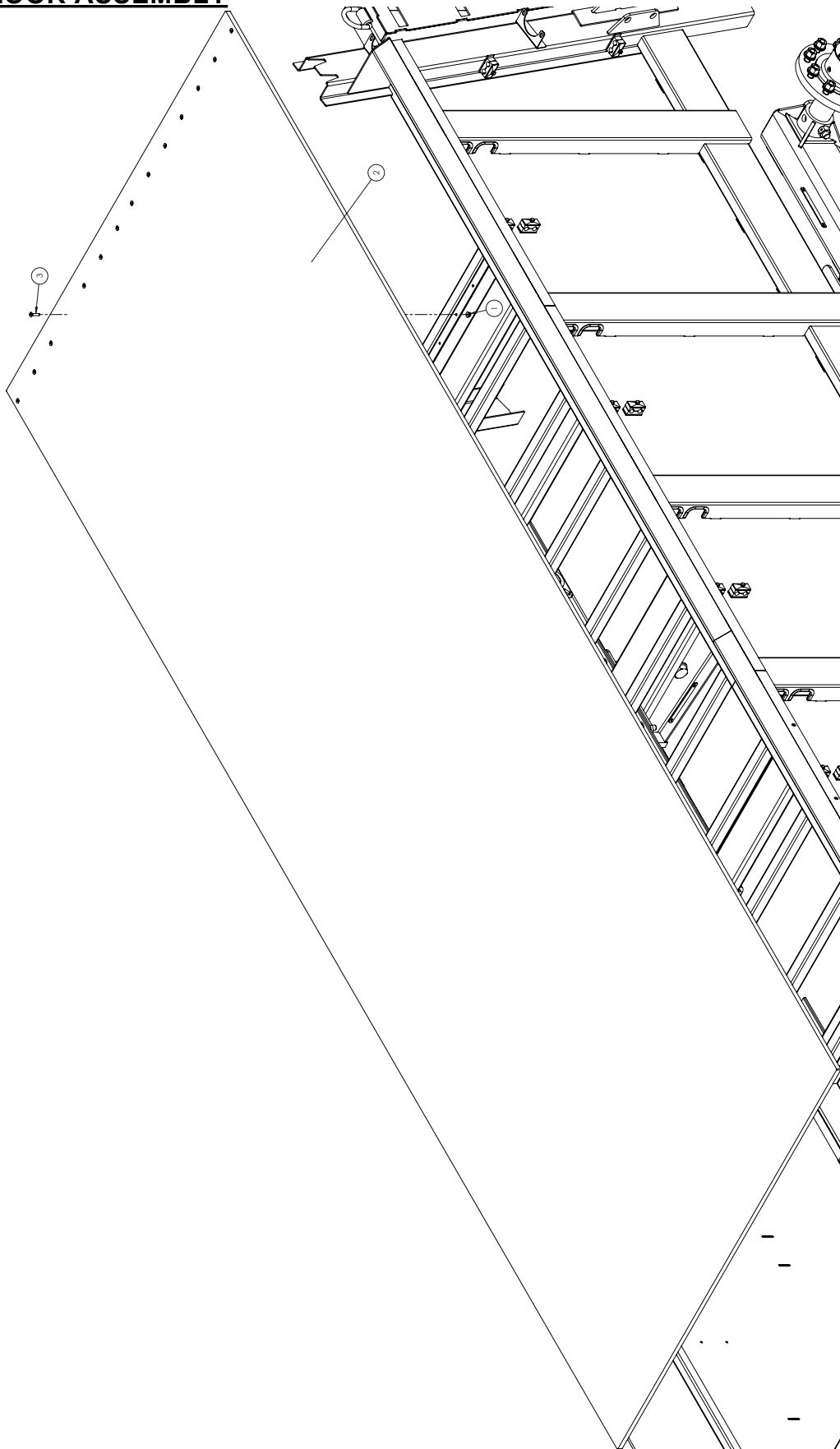

ITEM NO.	PART NUMBER	DESCRIPTION	QTY.
1	600110	NUT, HFH NYLOC 5/16-18	14
2	691790	PLASTIC FLOOR, MAIN	1
3	MP907624	SCREW - FHSCS 5/16-18 X	14

REAR GANG ASSEMBLY

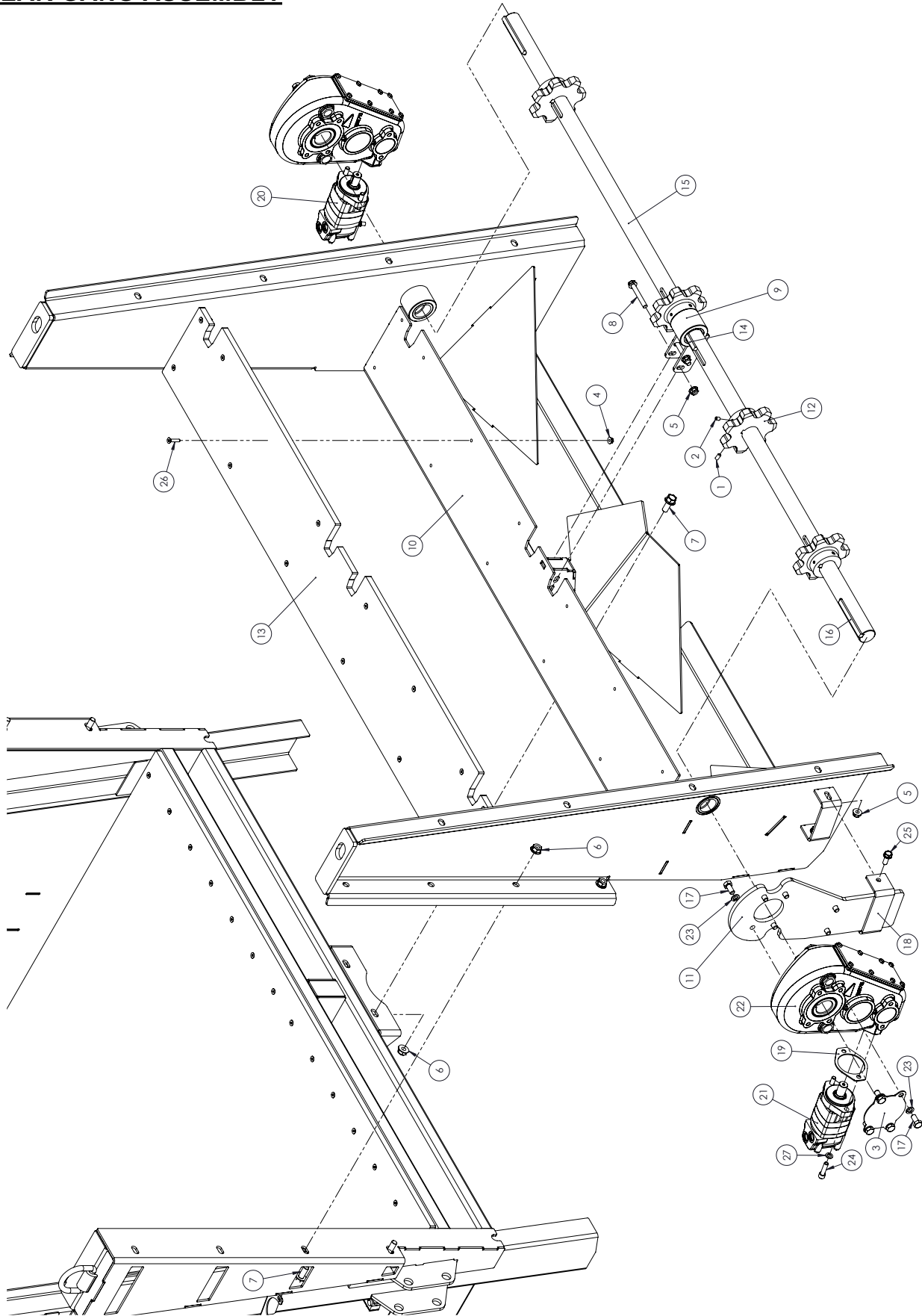

ITEM NO.	PART NUMBER	DESCRIPTION	QTY.
1	1070121	SET SCREW 3/8"-16 X 3/4"	4
2	120970	SCREW, HSSS 3/8-16 X 1/2"	4
3	598420	END PLATE, GEARBOX	2
4	600110	NUT, HFH NYLOC 5/16-18	14
5	600140	NUT, HFH NYLOC 1/2-13	6
6	600150	NUT, HFH NYLOC 5/8-11	6
7	600210	BOLT, HFH 5/8-11	6
8	607670	BOLT, HFH 1/2-13 X 3.50"	2
9	609500	MOUNT, BUSHING	1
10	690996	X900 REAR GANG	1
11	691714	TORQUE PLATE	2
12	691720	SPROCKET, 7 TOOTH 88C	4
13	691795	PLASTIC FLOOR, REAR	1
14	691832	KEY, SQUARE 2-1/4"	4
15	691833	REAR APRON SHAFT,	1
16	691834	KEY, SQ 1/2" X 5-11/16"	2
17	H4138	BOLT, HHCS M14-2 X 30 GR8.8 ZN	20
18	H610131	BRACKET, U	2
19	H610132	GASKET, MOTOR/GEARBOX	2
20	HC47-00-3121 *	MOTOR, HYD, RPM SENSOR	1
	HC47-00-3122	MOTOR, HYD, STANDARD	
21	HC47-00-3122	MOTOR, HYD, STANDARD	1
22	HO74-01-5069	GEARBOX, RIGHT ANGLE	2
23	HZ83-66-1414	WASHER, LOCK 5/8	20
24	HZ86-11-1245	SHCS, M12-1.75 X 45	4
25	MP904557	HHDBLT - 1/2-13 X 1-1/4" WHZ	4
26	MP907624	SCREW - FHSCS 5/16-18 X	14
27	MP907700	WASHER, LOCK M12	4
PART NUMBERS WITH * AFTER ARE ON SCALED UNITS ONLY			

GEARBOX ASSEMBLY (HO74-01-5069)

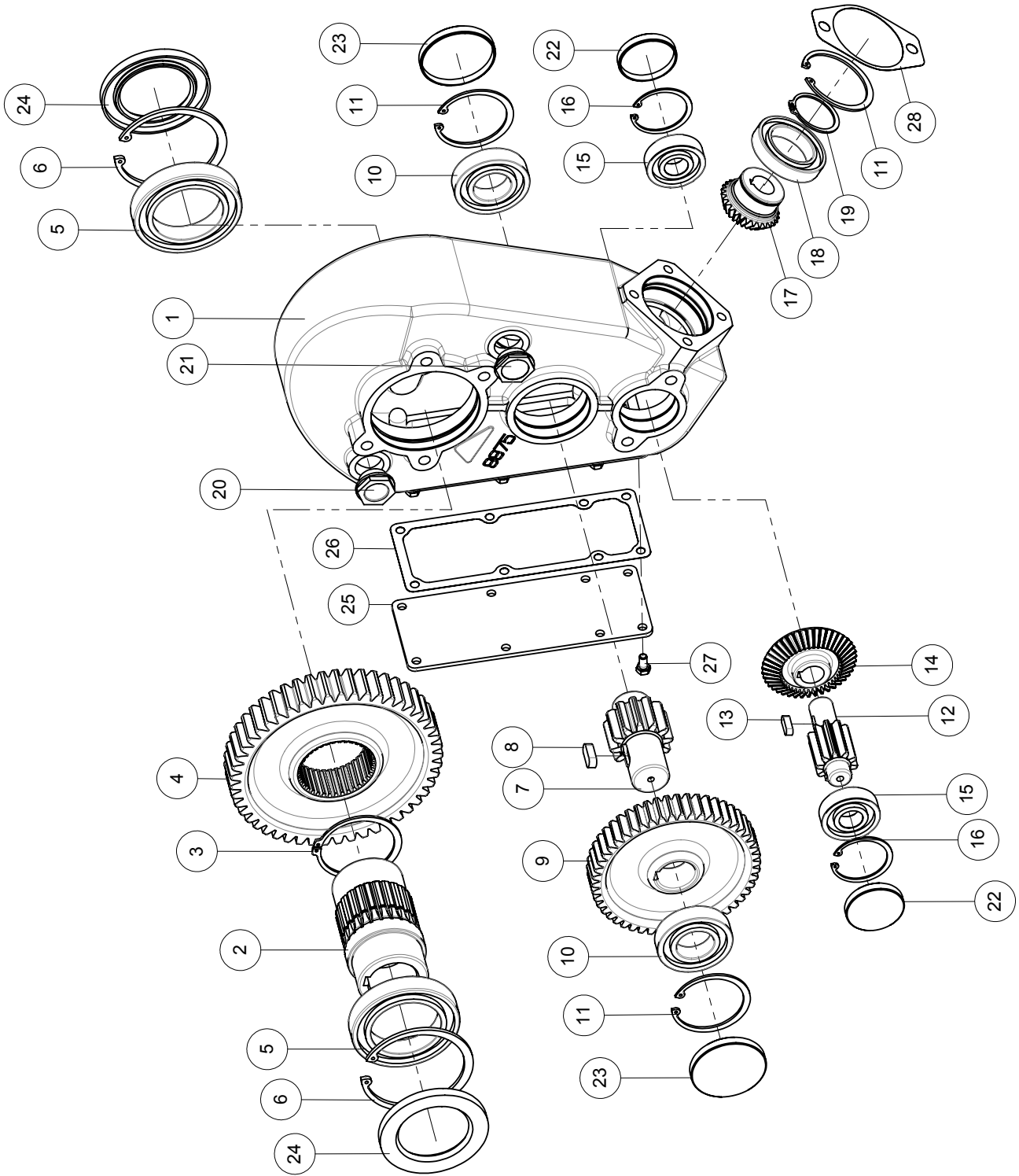

ITEM NO.	PART NUMBER	DESCRIPTION	QTY.
1	H9975	HOUSING RT350	1
2	H14551	HUB Ø2"	1
3	H9918	CIRCLIP E 82	1
4	H9974	GEAR Z=49	1
5	H9982	BEARING 6015	2
6	H9984	CIRCLIP I 115	2
7	H8670-5	PINION Z=12	1
8	H4174	KEY 12X8X30	1
9	H8670-4	GEAR Z=50	1
10	H3342	BEARING 6208	2
11	H3435	CIRCLIP I 80	3
12	H8670-3	PINION Z=10	1
13	H3396	KEY 8X7X25	1
14	H8670-2	GEAR Z=43	1
15	H8596	BEARING 6305	2
16	H3433	CIRCLIP I 62	2
17	H9923	PINION Z=28	1
18	H1538	BEARING 6010	1
19	H3428	CIRCLIP E 50	1
20	H9175	OIL BREATHER PLUG Ø1"GAS	2
21	H1831	OIL LEVEL INDIC. Ø1"GAS	2
22	H8625	PLUG Ø62	2
23	H8243	PLUG Ø80	2
24	H9983	OIL SEAL 75/115/10	2
25	H9976	COVER	1
26	H9977	GASKET	1
27	H3284	SCREW,HEX-HD M8X16	8
28	H610132	GASKET	1

LIGHTS ASSEMBLY

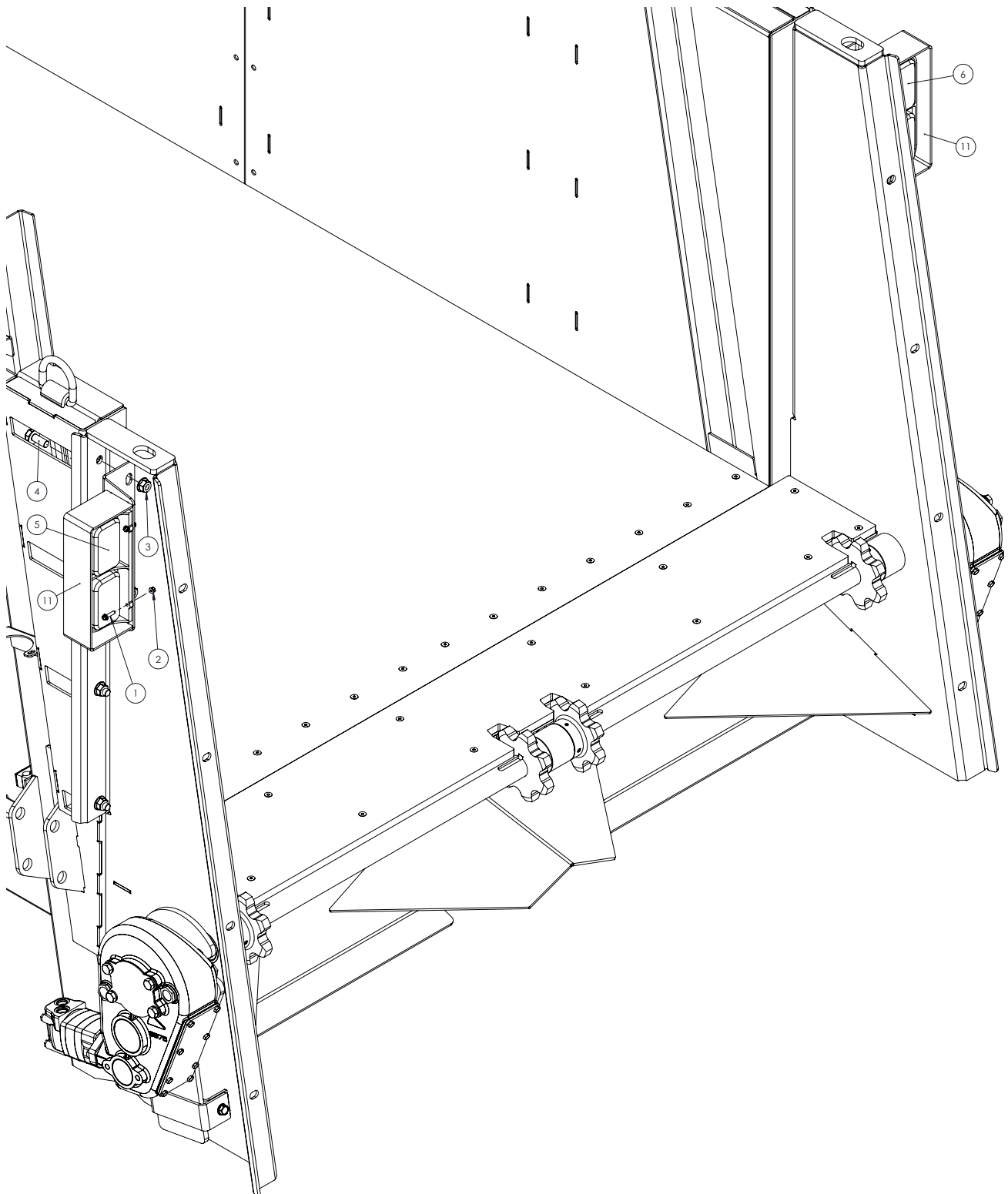

ITEM NO.	PART NUMBER	DESCRIPTION	QTY.
1	600020	BOLT, HFH 1/4-20 X 1.00"	8
2	600100	NUT, HFH NYLOC 1/4-20	8
3	600150	NUT, HFH NYLOC 5/8-11	4
4	600210	BOLT, HFH 5/8-11	4
5	642580	LIGHT, LED	1
6	642590	LIGHT, LED	1
NOT SHOWN	642600	HARNESS, Y-SPLITTER	1
	642610	HARNESS, 20' LIGHT	2
	642620	HARNESS, MAIN LIGHT	1
	642640	HARNESS, 3' EXTENSION	2
11	691940	LIGHT BRACKET	2

LIGHTS DIAGRAM

M-F DESIGNATION REFERS TO THE PINS NOT THE CONNECTOR HOUSING WHICH IS OPPOSITE

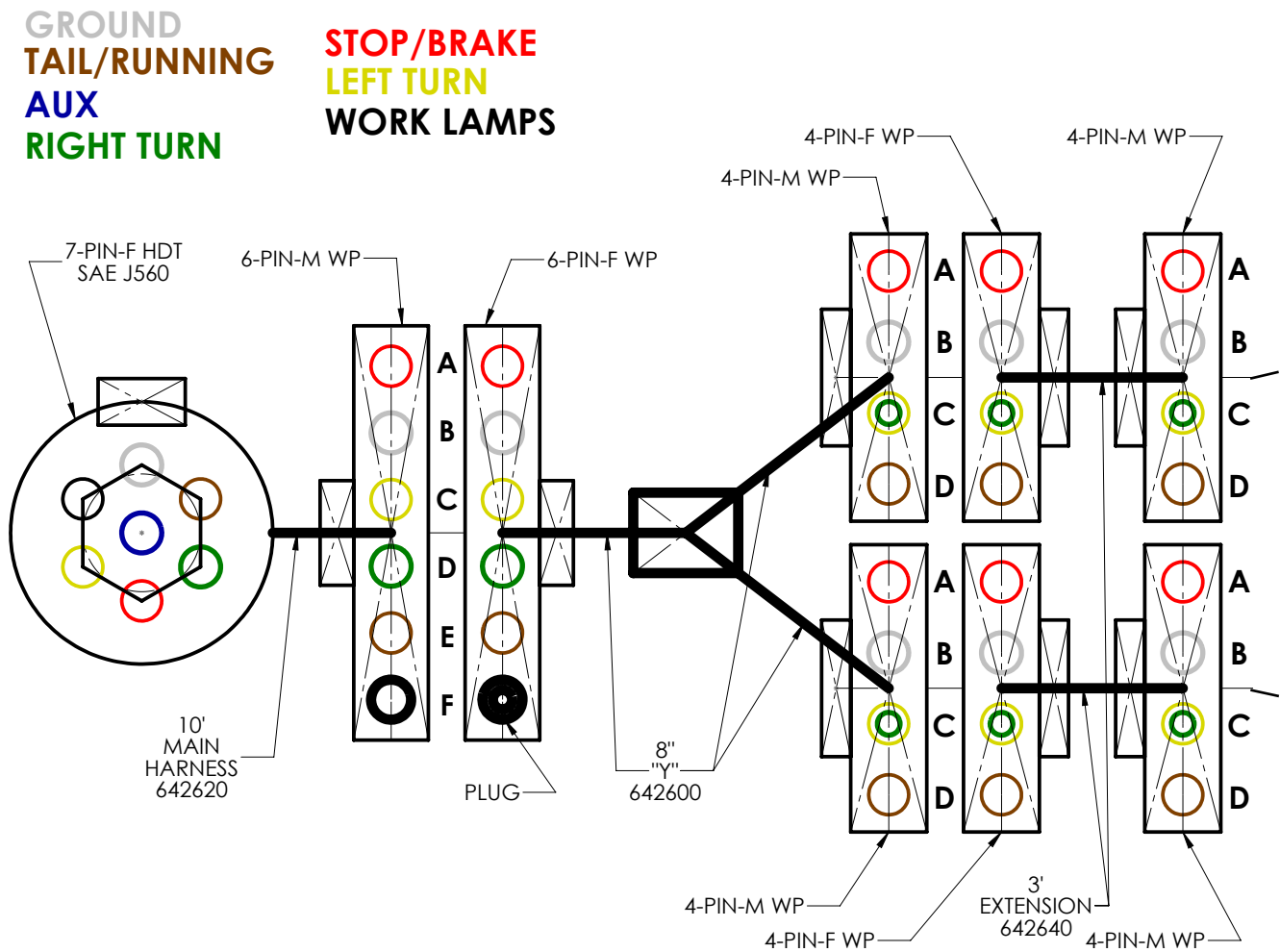

ALL END CONNECTORS ARE SHOWN LOOKING AT THE PIN SIDE WITH LOCKING TABS POINTING THE DIRECTION SHOWN

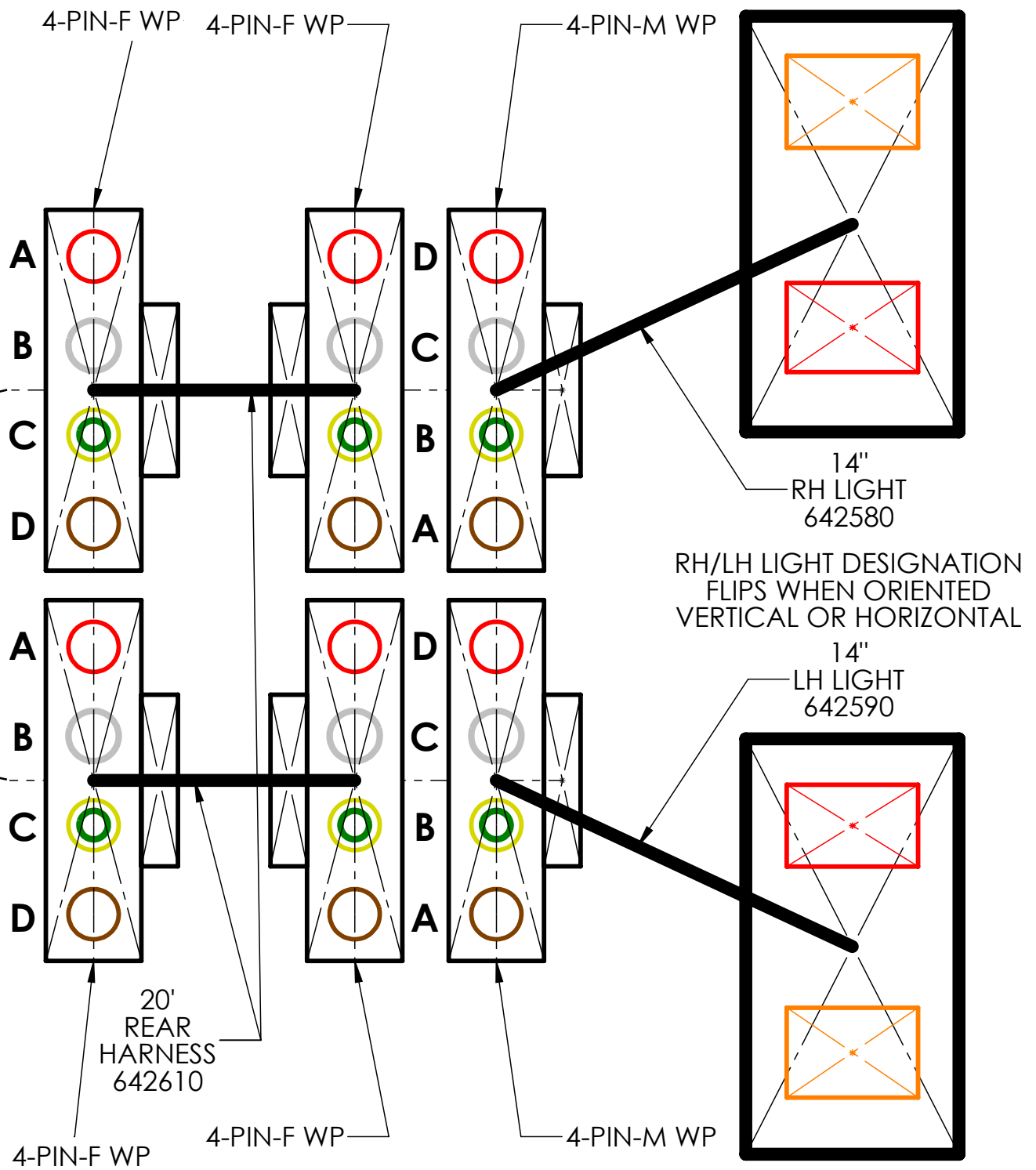

WHEEL ASSEMBLY (USED MILITARY)

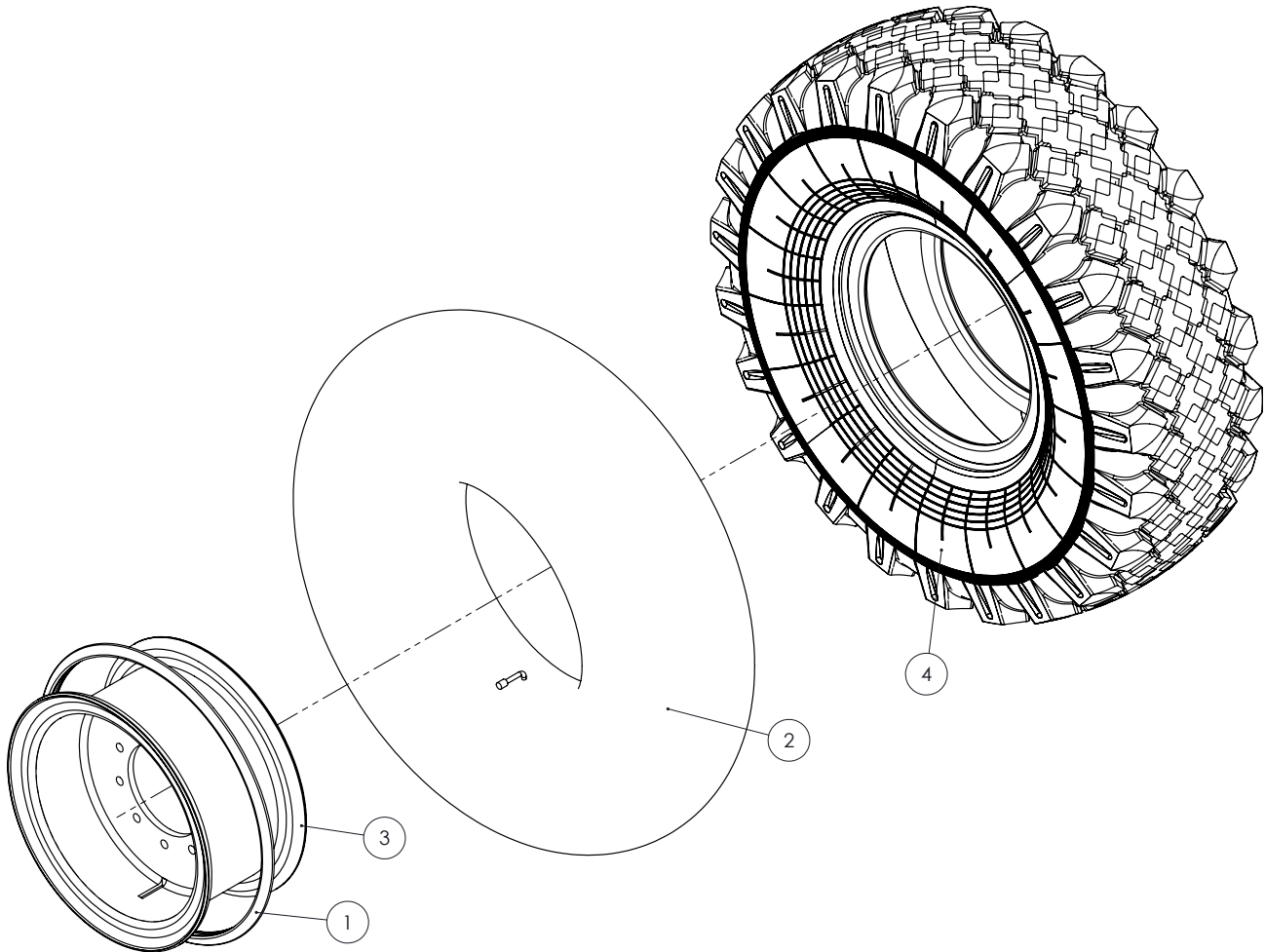

ITEM NO.	PART NUMBER	DESCRIPTION	QTY.
1	606100	RUBBER RING, WHEEL LOCKING	1
2	606105	TUBE, W/ STEM	1
3	659004	RIM, 1.5" OFFSET	1
4	HN69-07-4073	TIRE, 425/65RX22.5	1

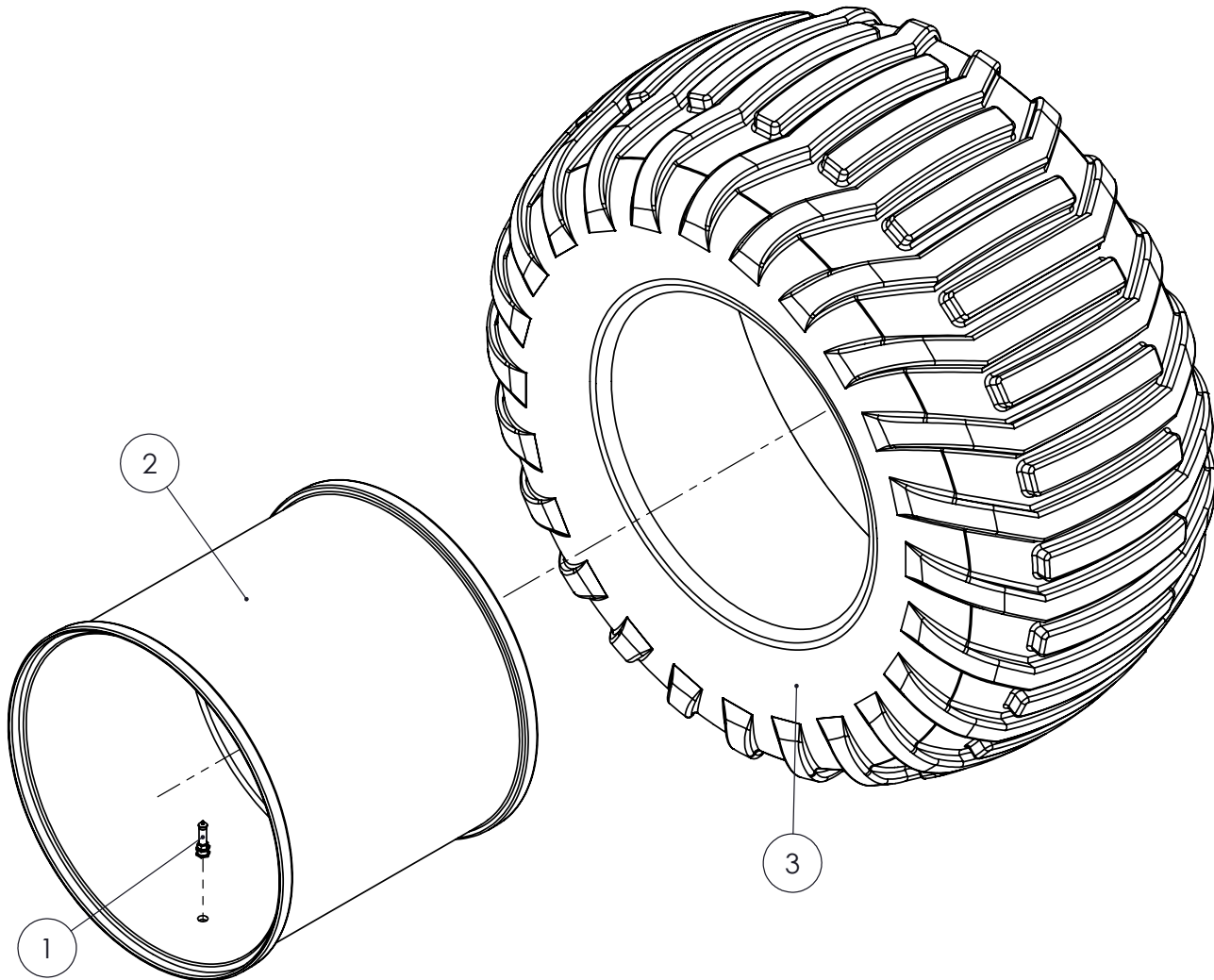
WHEEL ASSEMBLY (RH GOODYEAR FLOATATION 690623)

ITEM NO.	PART NUMBER	DESCRIPTION	QTY.
1	269490	STEEL VALVE STEM	1
2	659005	RIM, 22.5"X20"	1
3	MP12.11073	TIRE, 600/50R22.5	1

WHEEL ASSEMBLY (LH GOODYEAR FLOATATION 690624)

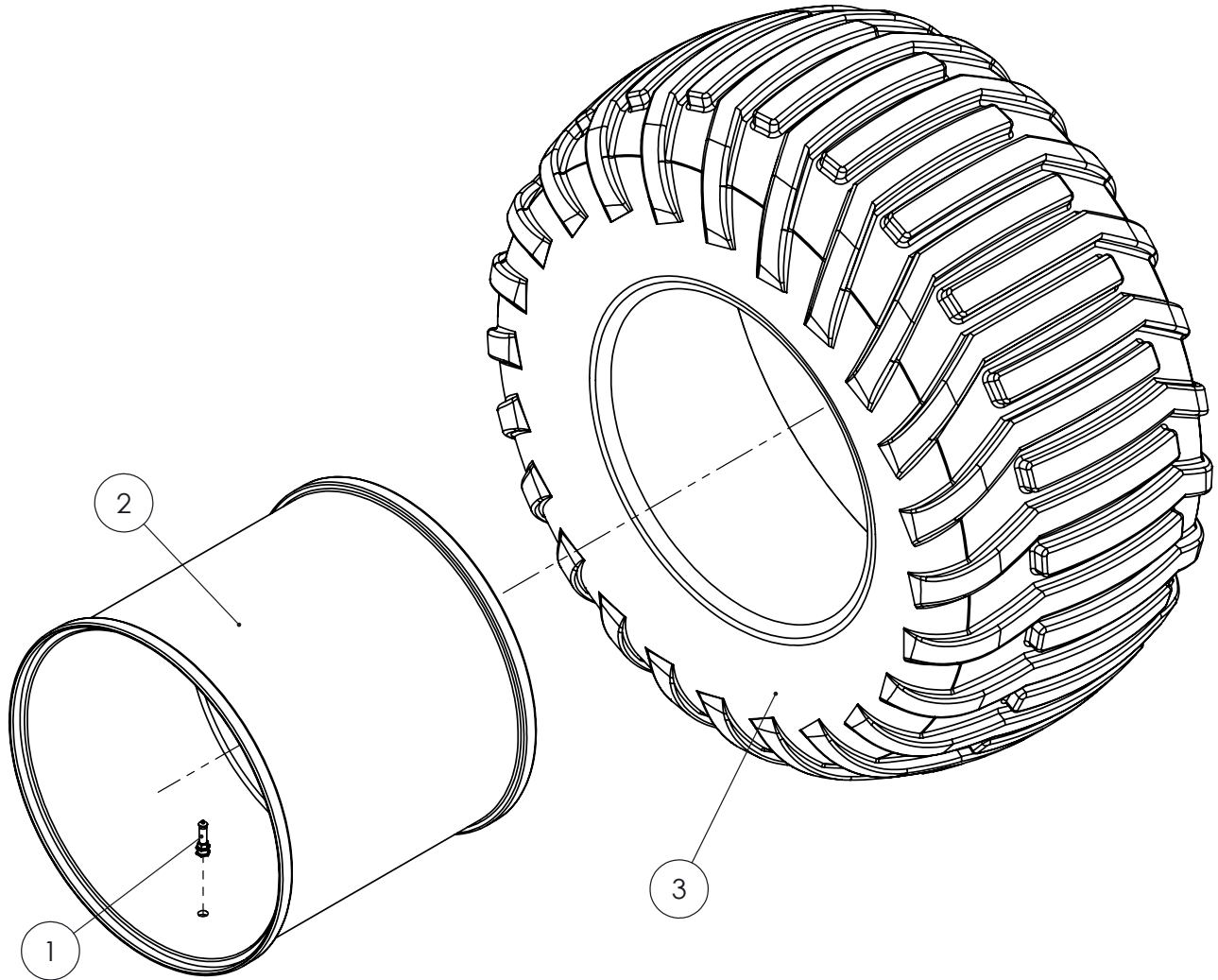

ITEM NO.	PART NUMBER	DESCRIPTION	QTY.
1	269490	STEEL VALVE STEM	1
2	659005	RIM, 22.5"X20"	1
3	MP12.11073	TIRE, 600/50R22.5	1

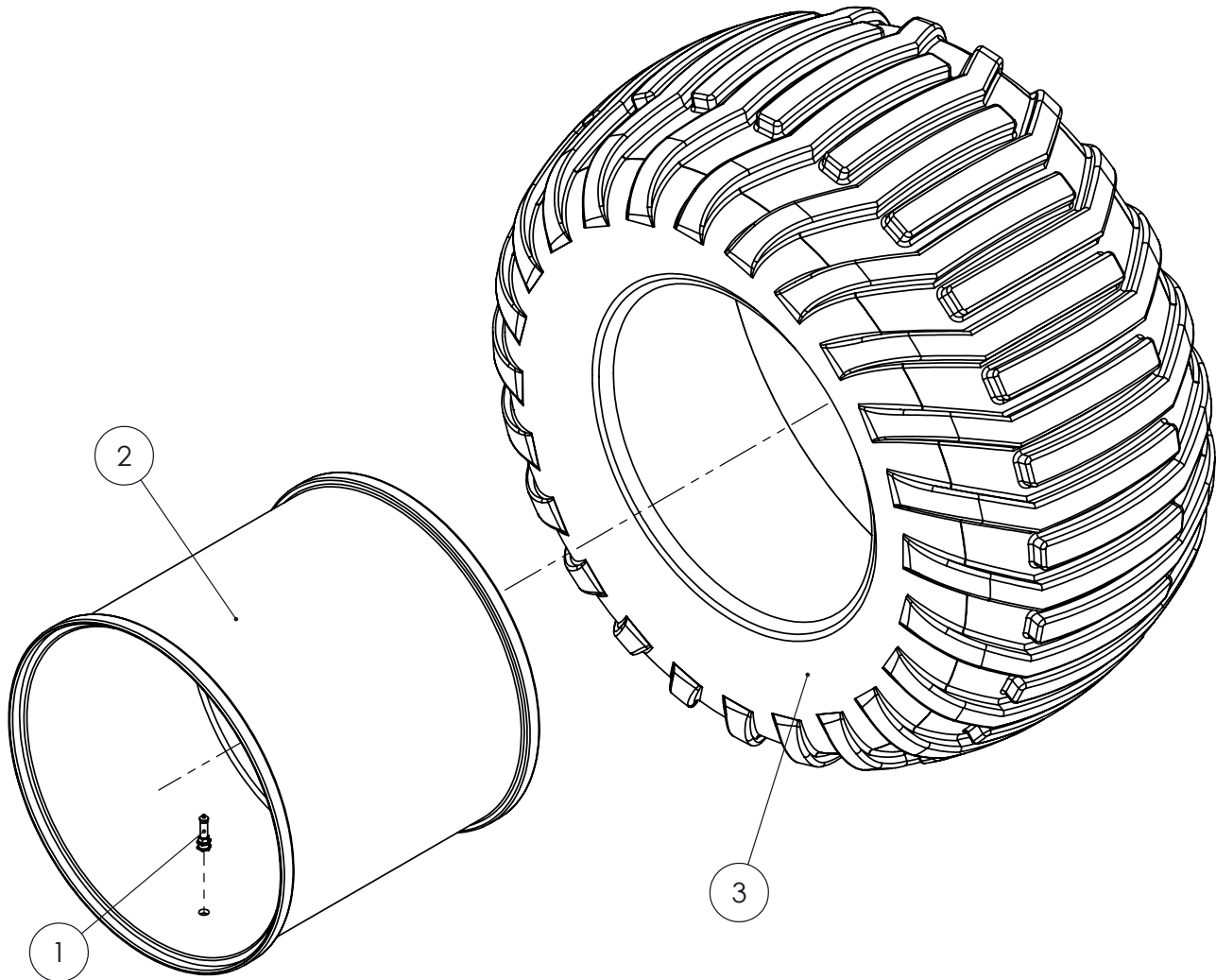
WHEEL ASSEMBLY (RH BKT FLOATATION 690621)

ITEM NO.	PART NUMBER	DESCRIPTION	QTY.
1	269490	STEEL VALVE STEM	1
2	659005	RIM, 22.5"X20"	1
3	690619	TIRE, 600/50R22.5	1

WHEEL ASSEMBLY (LH BKT FLOATATION 690622)

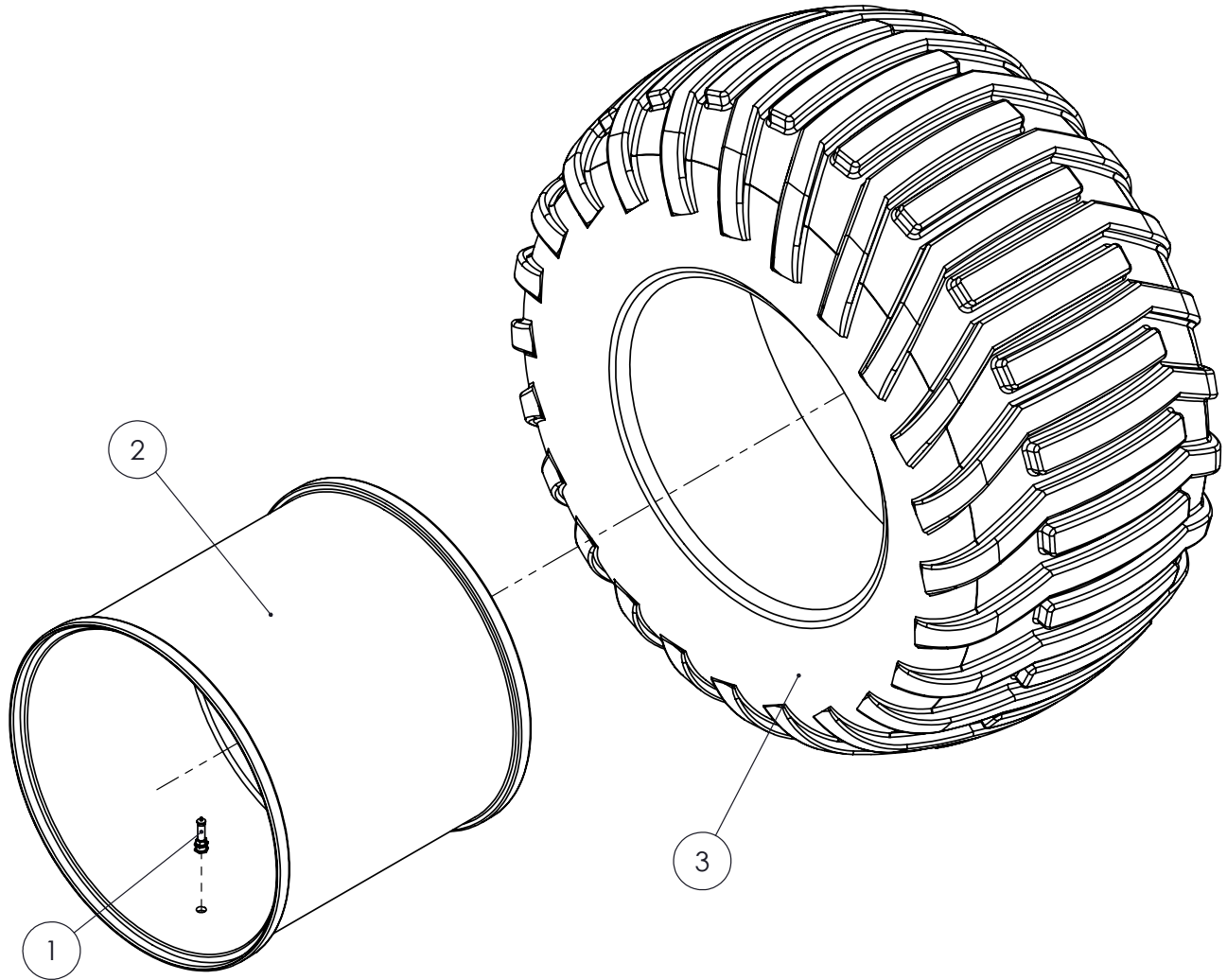

ITEM NO.	PART NUMBER	DESCRIPTION	QTY.
1	269490	STEEL VALVE STEM	1
2	659005	RIM, 22.5"X20"	1
3	690619	TIRE, 600/50R22.5	1

APRON CHAIN ASSEMBLY

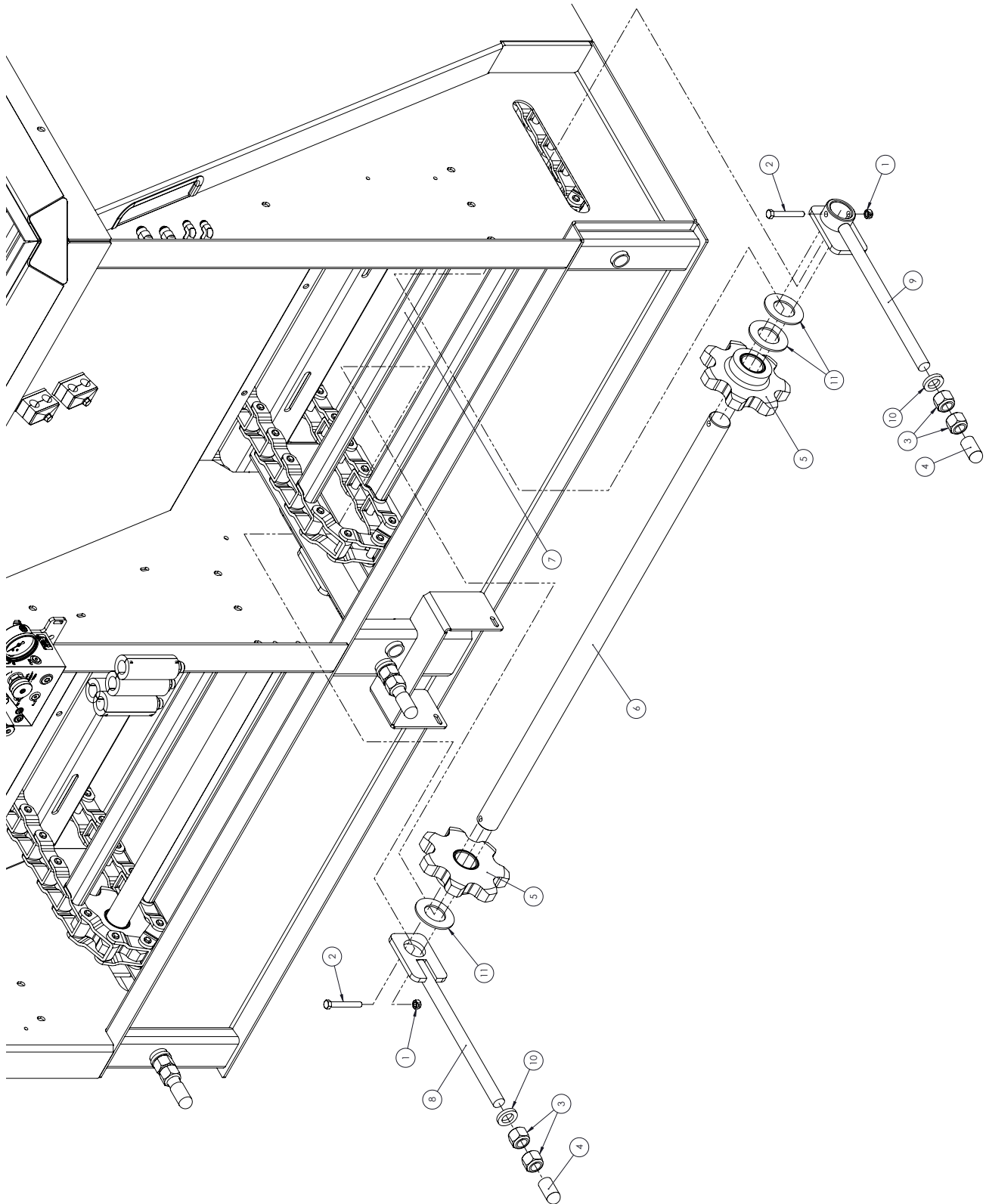

ITEM NO.	PART NUMBER	DESCRIPTION	QTY.
1	023060	NUT, LOCK 3/8-16 2 WAY	4
2	037790	BOLT, HHCS 3/8-16 X 2	4
3	600510	NUT, NYLOC 7/8-9 GR 8	8
4	691088	RUBBER CAP FOR 7/8" ROD	4
5	691725	SPROCKET, IDLER 7 TOOTH 88C	4
6	691838	APRON TENSIONER SHAFT	2
7*	691930	X900 88C CHAIN, COMPLETE	2
	691931	APRON CHAIN WLDT, SERVICE (10 LINKS, 2 SLATS)	-
	691932	APRON CHAIN WLDT, SERVICE (2 LINKS, 1 SLAT)	
	691939	APRON CHAIN SLAT (WELD IN)	
	397490P	88C CONNECTING LINK	
	034360	COTTER PIN FOR CONNECTING LINK	
8	H610203	INSIDE APRON TIGHTENER	2
9	H610206	OUTSIDE APRON TIGHTENER	2
10	I651239R1	WASHER, FLAT 29/32 X 1-1/2	4
11	V063596	WASHER, FLAT 1-1/2 SAE ZN	6
<p>SERVICE CHAINS INCLUDE CONNECTING LINKS AND COTTER PINS. COMPLETE APRON CHAINS DON'T INCLUDE CONNECTING LINKS OR COTTER PINS. COMPLETE APRON CHAINS ARE NOT ELIGIBLE FOR IMMEDIATE WARRANTY SERVICE. *X900 UNITS INCLUDING AND AFTER S/N AWX900001464 ARE 88C CHAIN & COMPONENTS. REFER TO MANUAL 690940 FOR PREVIOUS UNITS WITH 667XH CHAIN & COMPONENTS.</p>			

SLOP GATE ASSEMBLY

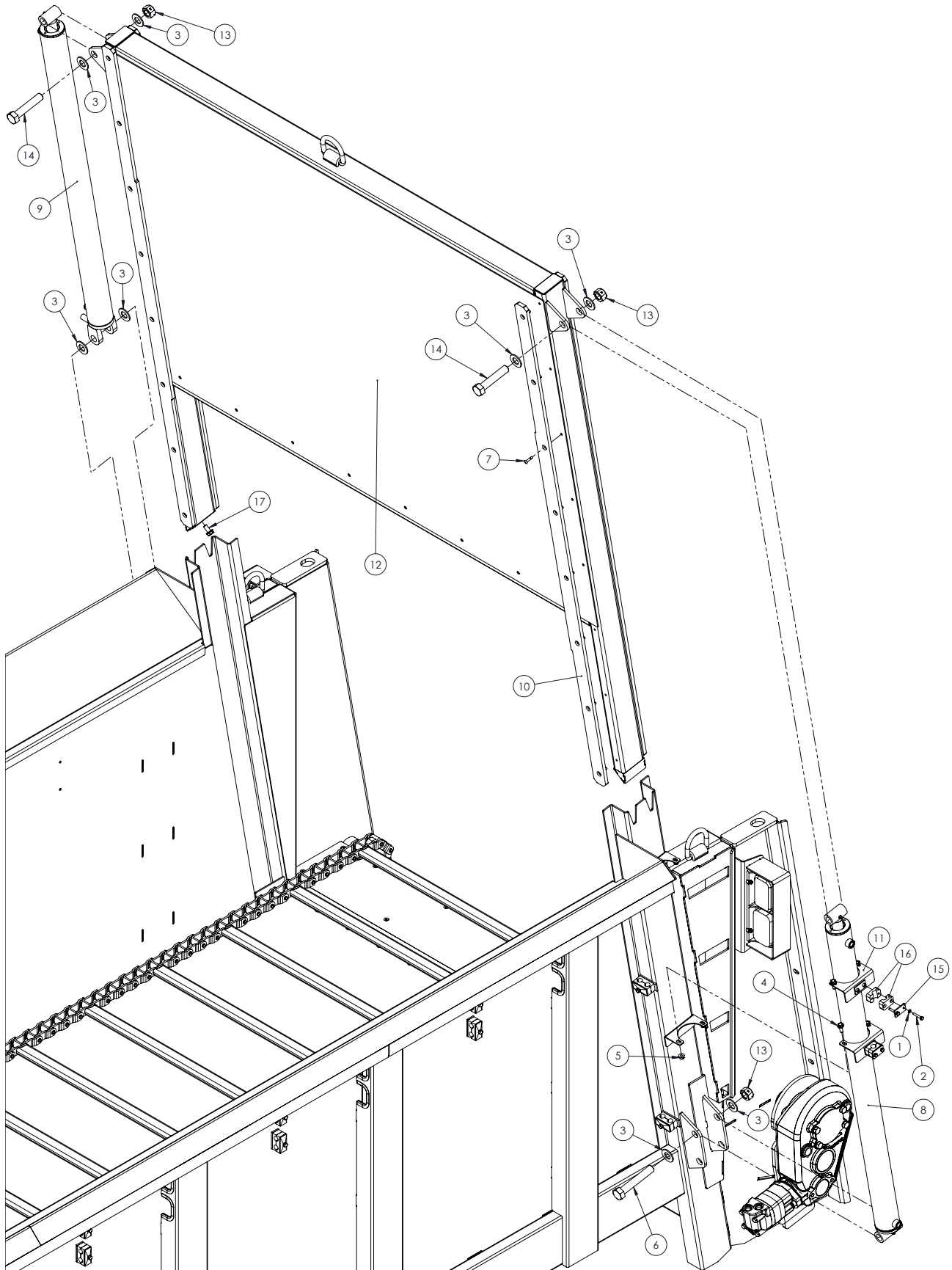

ITEM NO.	PART NUMBER	DESCRIPTION	QTY.
1	029440	WASHER, LOCK 1/4 SAE	8
2	047000	BOLT, HHCS 1/4-20 X 1-1/2	8
3	1107389 * 2 EXTRA	WASHER, FLAT 1 SAE	10
4	600050	BOLT, HFH 3/8-16 X 1.00"	8
5	600120	NUT, HFH NYLOC 3/8-16	8
6	600490	BOLT, HHCS 1-8 X 6"	2
7	660570	1/4" BLIND RIVET	32
8	660585	CYLINDER, HYD STANDARD	1
9	660586 *	CYLINDER, HYD SENSOR	1
	660585	CYLINDER, HYD STANDARD	
10	660590	PLASTIC SLIDE,	4
11	690765	CYLINDER HOLDER WLDMNT	4
12	690920	SLOP GATE WELDMENT,	1
13	990510	NUT, LOCK 2-WAY 1-8	4
14	991060	BOLT, HHCS 1-8 X 5	2
15	HC14-00-3169	TOP CAP, HOSE CLAMP	4
16	HC14-00-3171	SECTION, HOSE CLAMP	8
17	MP903952	HHDBLT - 1/2-13 X 1 WHZ	2
PART NUMBERS WITH * AFTER ARE ON SCALED UNITS ONLY			

FLASHING ASSEMBLY

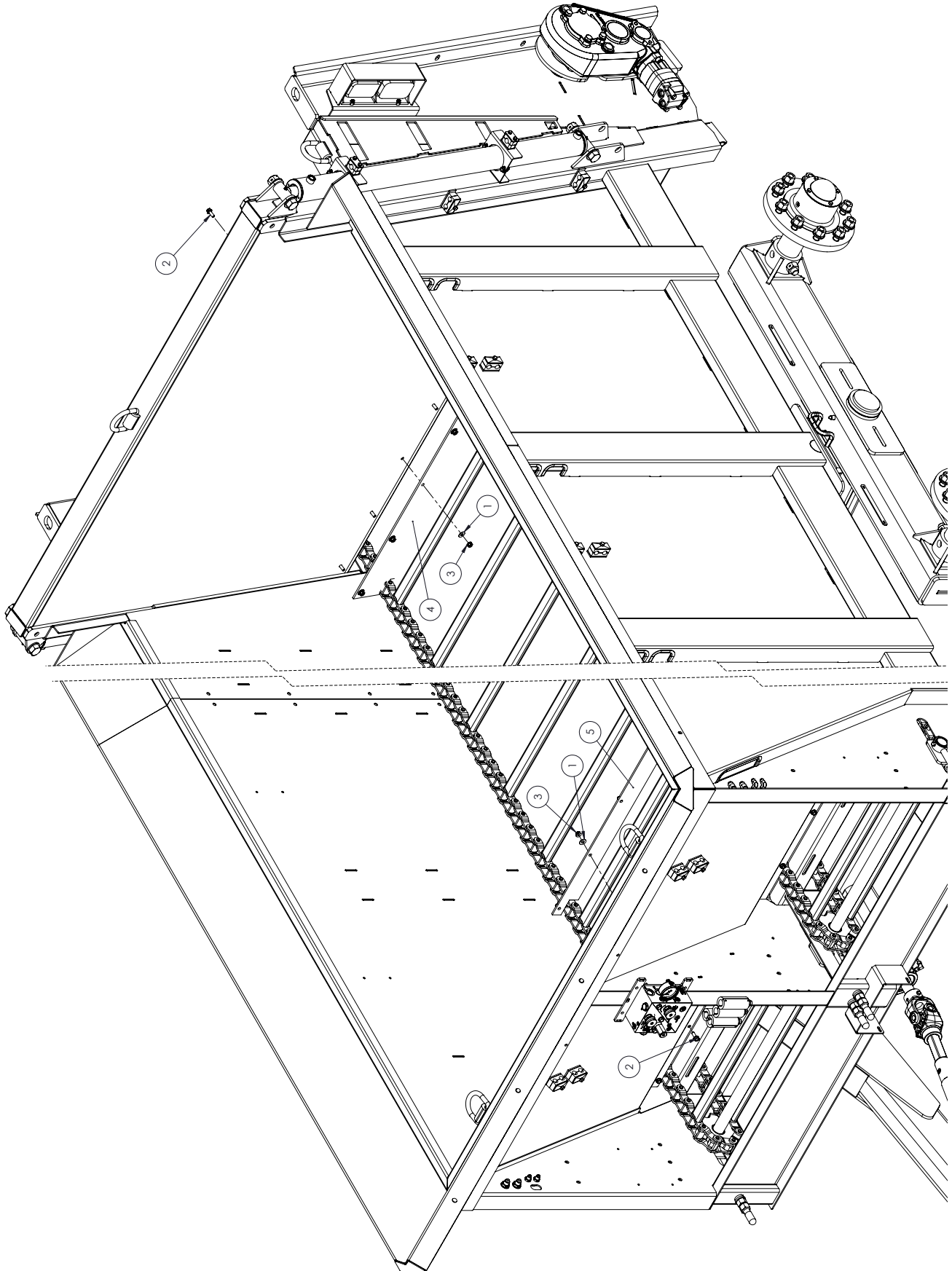

ITEM NO.	PART NUMBER	DESCRIPTION	QTY.
1	021190	WASHER, FLAT 3/8 STD	16
2	600050	BOLT, HFH 3/8-16 X 1.00"	16
3	600120	NUT, HFH NYLOC 3/8-16	16
4	691604	SLOP GATE FLAP,	1
5	691605	FRONT FLAP, 88C CHAIN	1

BEATERS ASSEMBLY

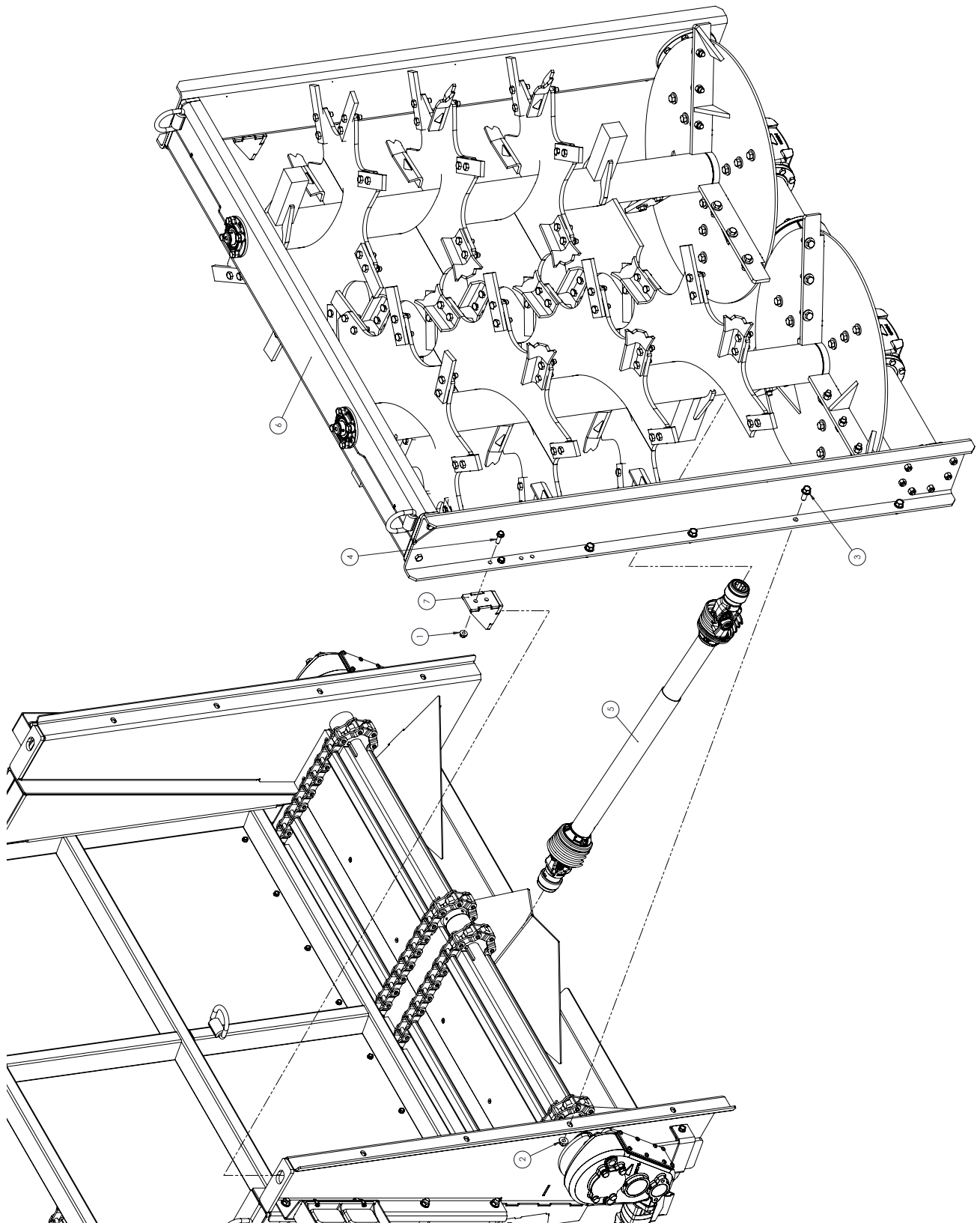

ITEM NO.	PART NUMBER	DESCRIPTION	QTY.
1	600140	NUT, HFH NYLOC 1/2-13	4
2	600150	NUT, HFH NYLOC 5/8-11	8
3	600210	BOLT, HFH 5/8-11	8
4	600580	BOLT, HFH 1/2-13 X 1-1/2"	4
5	H160048	REAR PTO ASSEMBLY X900	1
6	H160503	BEATERS, V180/X900	1
7	H200234	BEATER LOCATOR	2

BEATERS ASSEMBLY (H160503) (GEN 1)

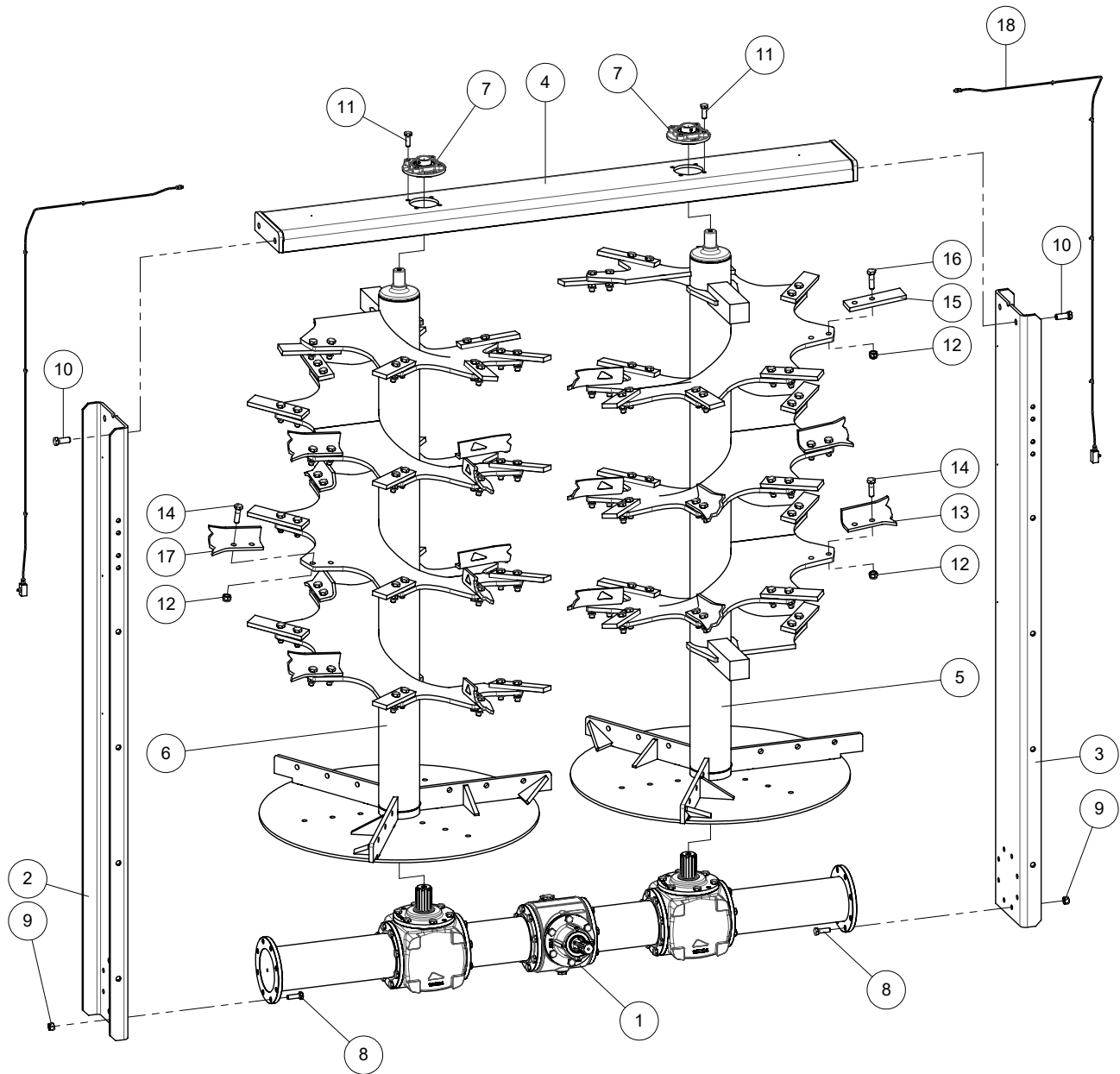

ITEM NO.	PART NUMBER	DESCRIPTION	QTY.
1	H14250	GEARBOX SRT18/2100	1
2	H14790	RIGHT PANEL	1
3	H14791	LEFT PANEL	1
4	H14792	CROSS BAR	1
5	H19688	LEFT BEATER	1
6	H19689	RIGHT BEATER	1
7	H9905	UCFC 208 Ø40	2
8	H3489	SCREW, HEX-HD M14X45	16
9	H1799	NUT M14	16
10	H9156	SCREW, HEX-HD M18X45	4
11	H3311	SCREW, HEX-HD M14X40	8
12	H9113	NUT M16X1.5	112
13	H14626	RIGHT BLADE	10
14	H14061	SCREW, HEX-HD M16X1.5X55	40
15	H14787	KNIFE	36
16	H14054	SCREW, HEX-HD M16X1.5X60	72
17	H14627	LEFT BLADE	10
18	H14780	LUBRIFICATION KIT	1

BEATERS ASSEMBLY (H160503) (GEN 2)

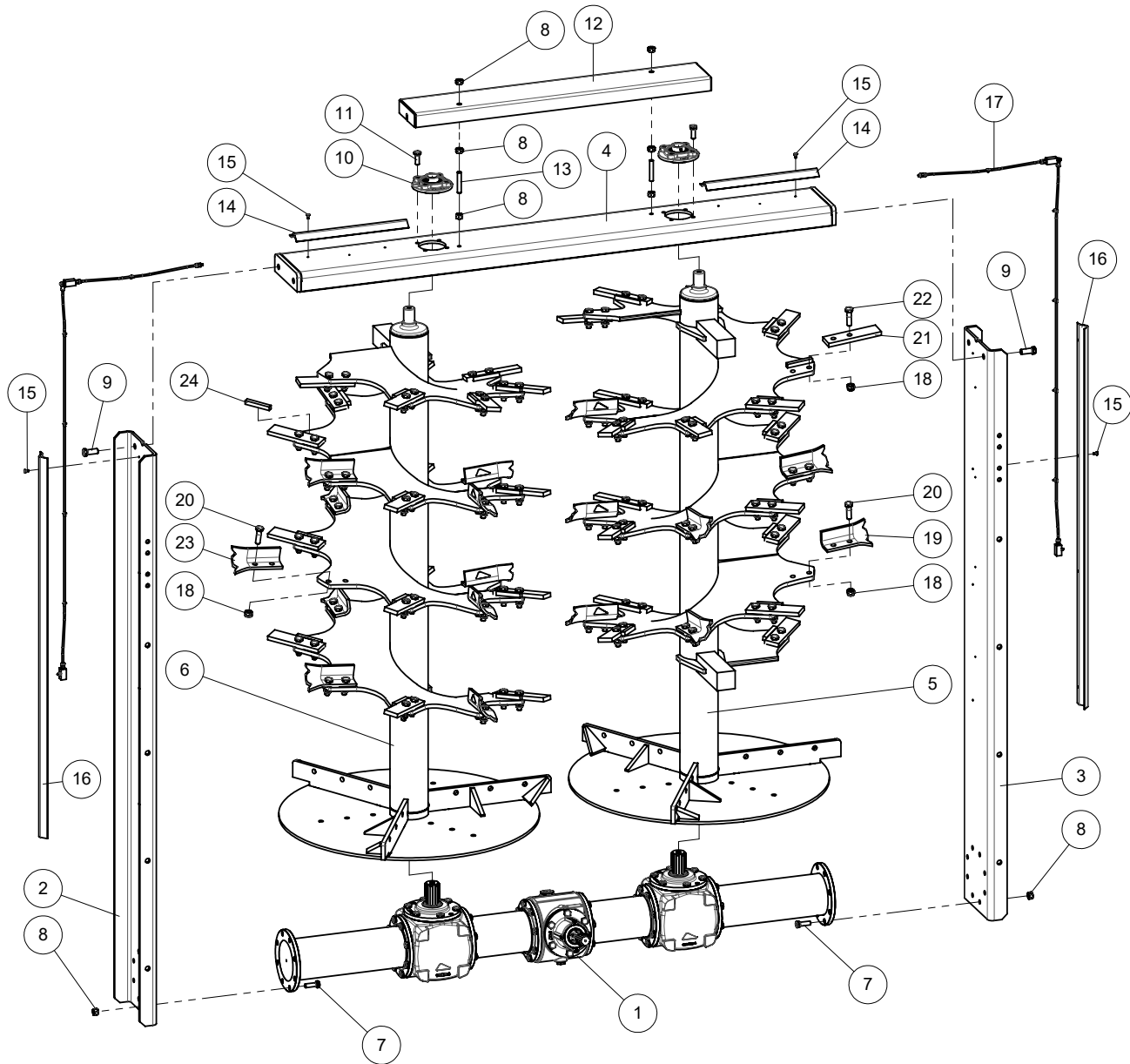

ITEM NO.	PART NUMBER	DESCRIPTION	QTY.
1	H14250	GEARBOX SRT18/2100	1
2	H21336	RIGHT PANEL	1
3	H21337	LEFT PANEL	1
4	H21330	CLOSED CROSSBAR	1
5	H21338	LEFT BEATER	1
6	H21339	RIGHT BEATER	1
7	H3489	SCREW, HEX-HD M14X45	16
8	H1799	NUT M14	22
9	H9156	SCREW, HEX-HD M18X45	4
10	H9905	UCFC 208 Ø40	2
11	H3311	SCREW, HEX-HD M14X40	8
12	H14774	COVER	1
13	H9859	THREADED BAR M14X80	2
14	H21341	PROTECTION L=438	2
15	H3283	SCREW, HEX-HD M6X12	12
16	H18497	PROTECTION L=1482	2
17	H21340	LUBRIFICATION KIT NYLON Ø6	1
18	H9113	NUT M16X1.5	112
19	H14626	RIGHT BLADE	10
20	H14061	SCREW, HEX-HD M16X1.5X55	40
21	H14787	KNIFE	36
22	H14054	SCREW, HEX-HD M16X1.5X60	72
23	H14627	LEFT BLADE	10
24	H14619	REINFORCEMENT	36

ITEM NO.	PART NUMBER	DESCRIPTION	QTY.
1	H9126	HOUSING	1
2	H12624	LATERAL HOUSING	2
3	H9137	LEFT THREADED RING	2
4	H9011	WASHER	3
5	H9051	BEVEL PINION Z=13	2
6	H1259	BEARING 32209	4
7	H1531	BEARING 6311	1
8	H10381	GEAR Z=24	1
9	H3430	CIRCLIP E 55	1
10	H9839	SHAFT L=880	1
11	H9138	RIGHT THREADED RING	1
12	H9124	SPACER	2
13	H9139	O-RING 2212	2
14	H3549	SCREW, HEX-HD M14X35	66
15	H9111	CALOTTE	2
16	H7481	OIL SEAL 70/100/10-DL	2
17	H13103	BEARING 6311-2RS	2
18	H12645	SHAFT	2
19	H9123	SPACER	2
20	H9052	GEAR Z=22	2
21	H3349	BEARING 32210	2
22	H9134	GASKET	2
23	H14252	SPACER L=456	2
24	H9135	GASKET	6
25	H14254	SPACER L=273	1
26	H9707	OIL PLUG Ø1/2"GAS	1
27	H9179	OIL LEV. INDIC. Ø1"GAS ALL.	1
28	H9301	OIL BREATHER PLUG Ø1"GAS	1
29	H14255	SPACER L=273	1
30	H9133	GASKET	1
31	H10380	BEVEL PINION Z=17	1
32	H9127	HUB	1
33	H9053	SHAFT	1
34	H7480	OIL SEAL 55/85/10-DL	1
35	H9783	COMPLETE HUB	1
36	H12657	COMPLETE CALOTTE	2

LITTER KIT (OPTIONAL)

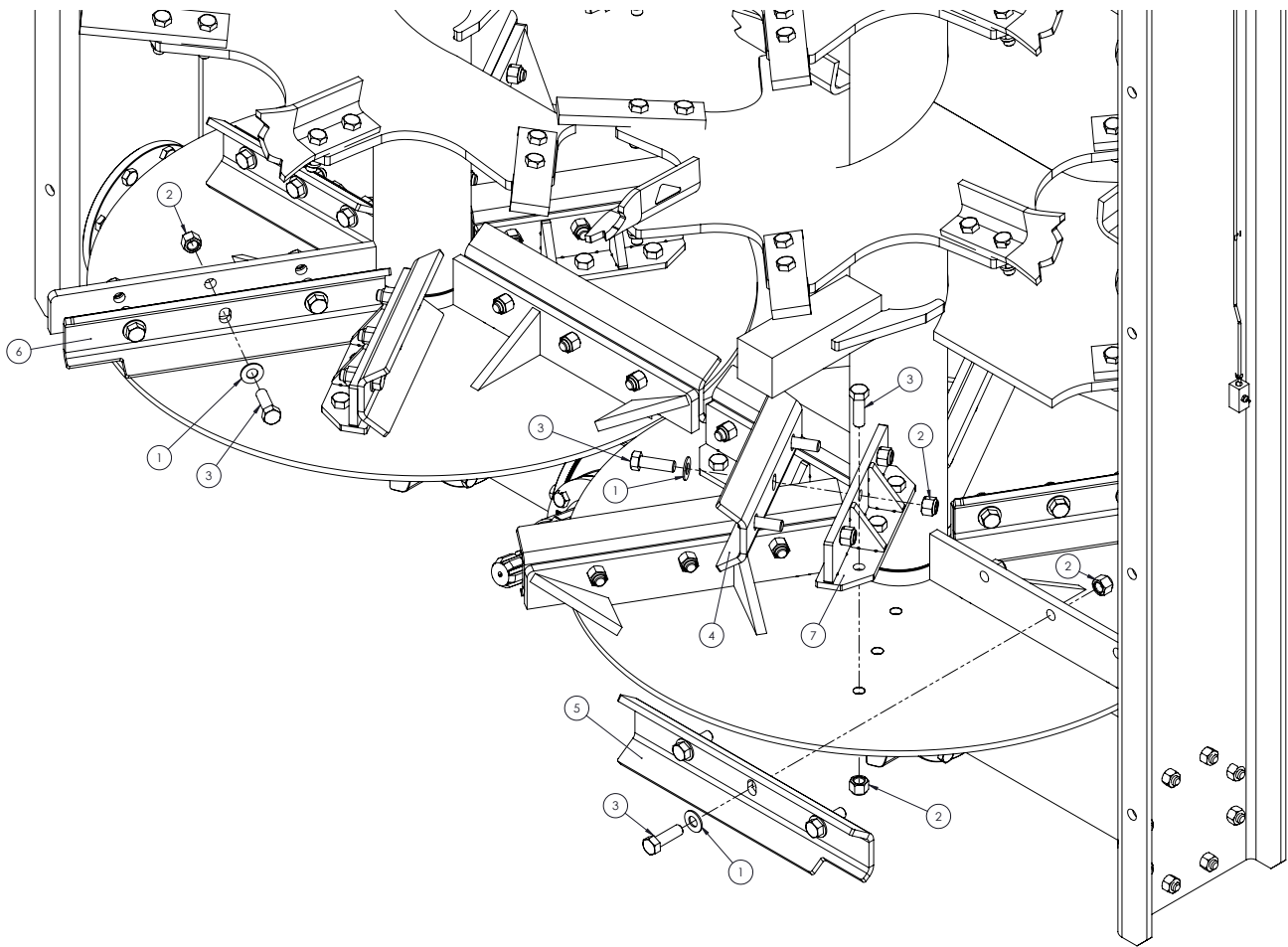

ITEM NO.	PART NUMBER	DESCRIPTION	QTY.
1	035210	WASHER, FLAT 5/8	36
2	1100840	NUT, ESNA 5/8-18	54
3	213250	BOLT, HHCS 5/8-18	54
4	691003	SHORT SCOOP KNIFE	6
5	691004	LONG SCOOP, LH	3
6	691005	LONG SCOOP, RH	3
7	691006	SHORT SCOOP BRACE	6

SHAFT ASSEMBLY (H160048)

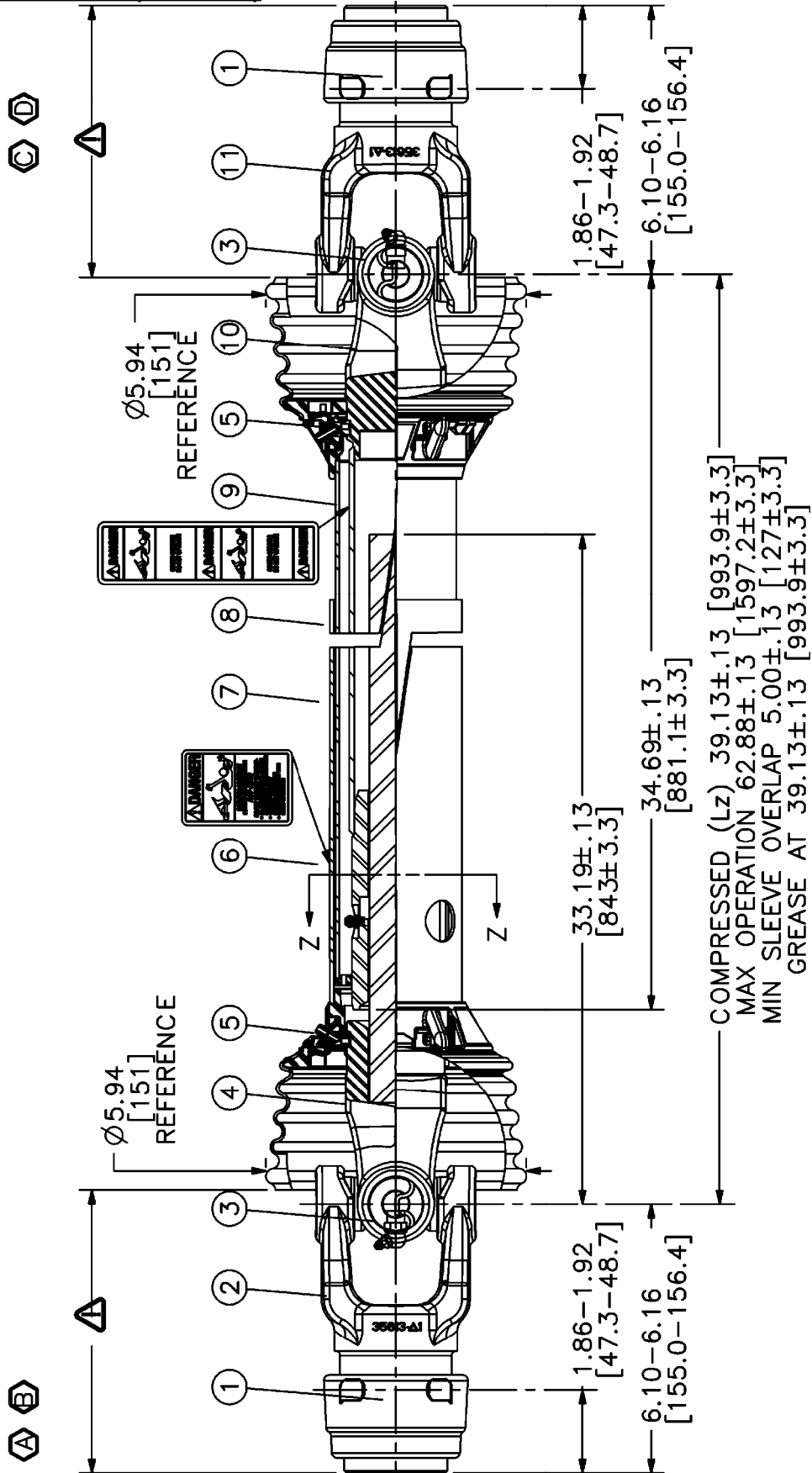

ITEM NO.	PART NUMBER	DESCRIPTION	QTY.
A	H93-25398	JOINT & SHAFT HALF ASM. W/GUARD	1
B	H95-25398	JOINT & SHAFT HALF ASM.	1
C	H92-25398	JOINT & TUBE HALF ASM. W/GUARD	1
D	H94-25398	JOINT & TUBE HALF ASM.	1
1	H26-13387	SSL/AUTO-LOK REPAIR KIT	2
2	H35041-1850	SAFETY SLIDE LOCK YOKE ASM.	1
3	H03-10045	35R CROSS KIT	2
4	H99-25396	YOKE & SHAFT (1.19 SQ.)	1
5	H19-11143	GUARD REPAIR KIT	2
6	H13-10021	SAFETY SIGN	1
7	H97-25396	OUTER GUARD	1
8	H96-25398	INNER GUARD	1
9	H13-10022	SAFETY SIGN	1
10	H98-25398	YOKE, TUBE, & SLIP SLEEVE	1
11	H35610-1005	SAFETY SLIDE LOCK ASM.	1

ROCK GUARD ASSEMBLY

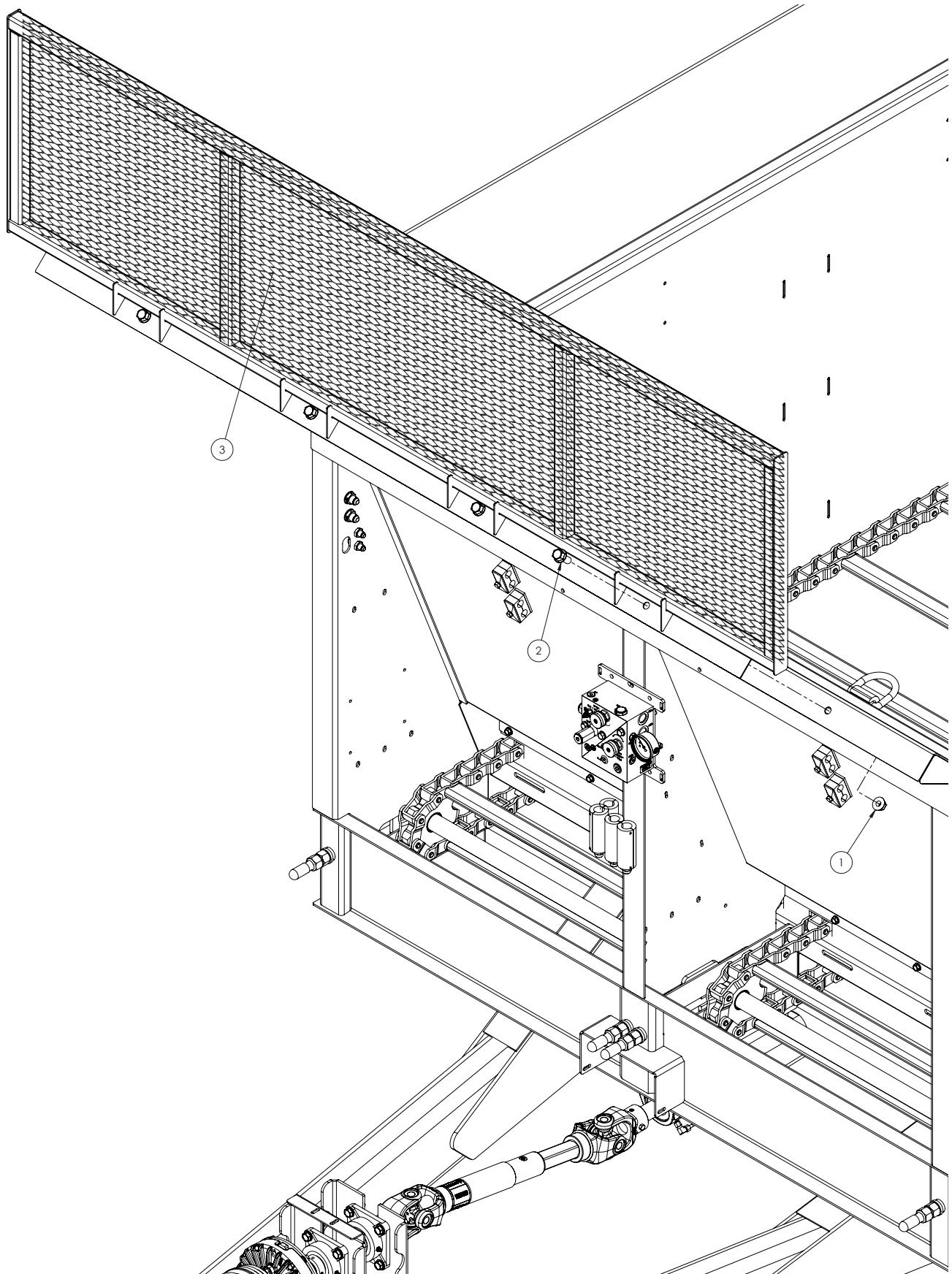

ITEM NO.	PART NUMBER	DESCRIPTION	QTY.
1	600150	NUT, HFH NYLOC 5/8-11	4
2	600210	BOLT, HFH 5/8-11	4
3	690755	ROCK GUARD WELDMENT,	1

SHIELDS ASSEMBLY

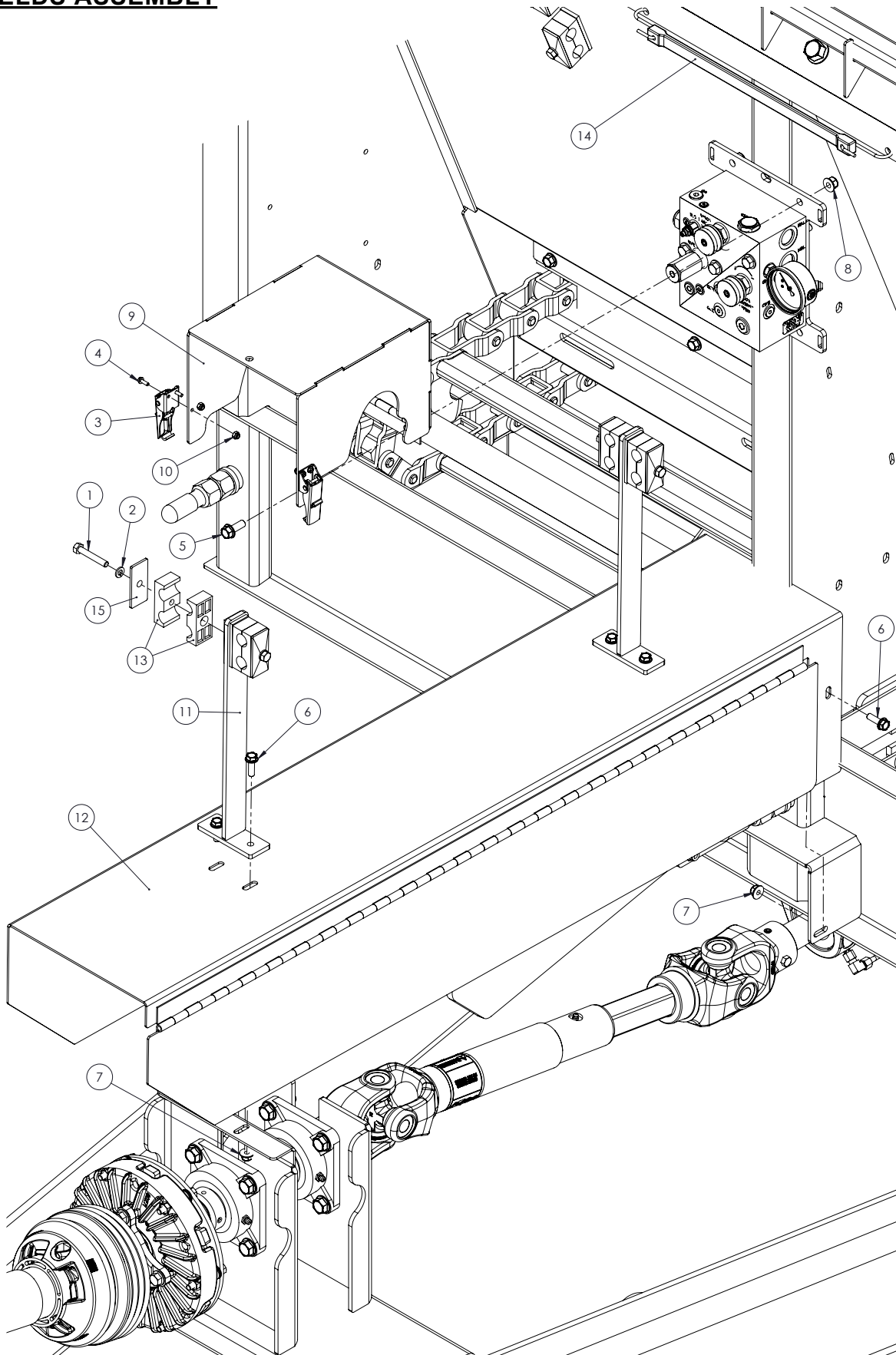

ITEM NO.	PART NUMBER	DESCRIPTION	QTY.
1	017120	BOLT, HHCS 5/16-18 X 2 G	4
2	023620	WASHER, LOCK 5/16	4
3	163400	LATCH, TENSION 17L	2
4	600015	BOLT, HFH #8-32 X 0.50"	4
5	600050	BOLT, HFH 3/8-16 X 1.00"	2
6	600060	BOLT, HFH 5/16-18 X 1"	6
7	600110	NUT, HFH NYLOC 5/16-18	6
8	600120	NUT, HFH NYLOC 3/8-16	2
9	690690	SHIELD WLDT, BLOCK	1
10	710802	NUT, LOCK #8-32 NYLOCK	4
11	H160022	LONG HOSE HOLDER	2
12	H160025	SHIELD WLDT, PTO	1
13	MP17.01144	SECTION, HOSE CLAMP	8
14	MP906533	RUBBER STRAP, 15"	1
15	U51800177	TOP CAP, HOSE CLAMP	4

MANUAL ASSEMBLY

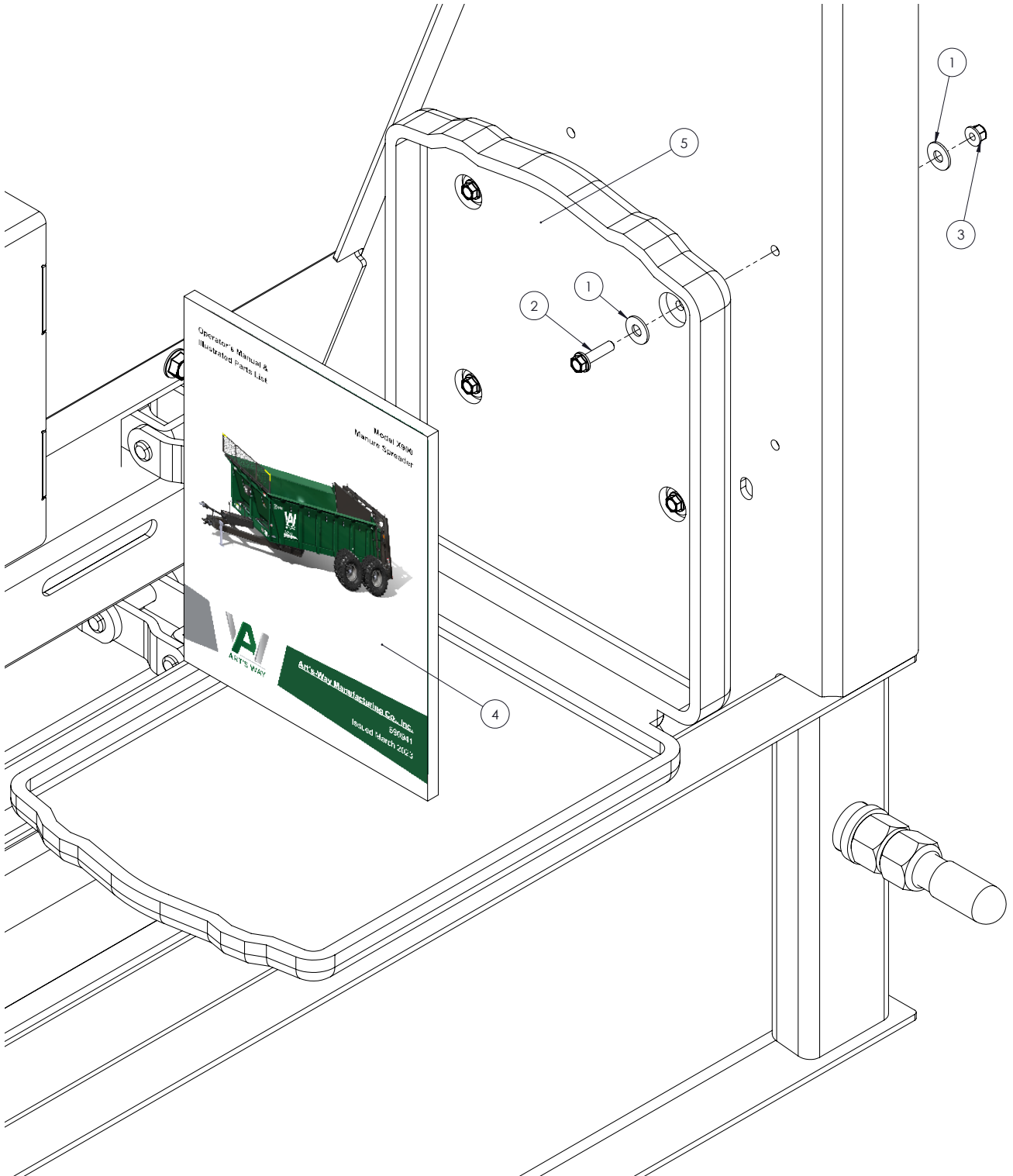

ITEM NO.	PART NUMBER	DESCRIPTION	QTY.
1	023260	WASHER, FLAT 1/4 STD	8
2	600020	BOLT, HFH 1/4-20 X 1.00"	4
3	600100	NUT, HFH NYLOC 1/4-20	4
4	690941	MANUAL, X900 88C OPM+IPL	1
5	720900	STORAGE BOX, MANUAL FLAT	1

DECALS ASSEMBLY

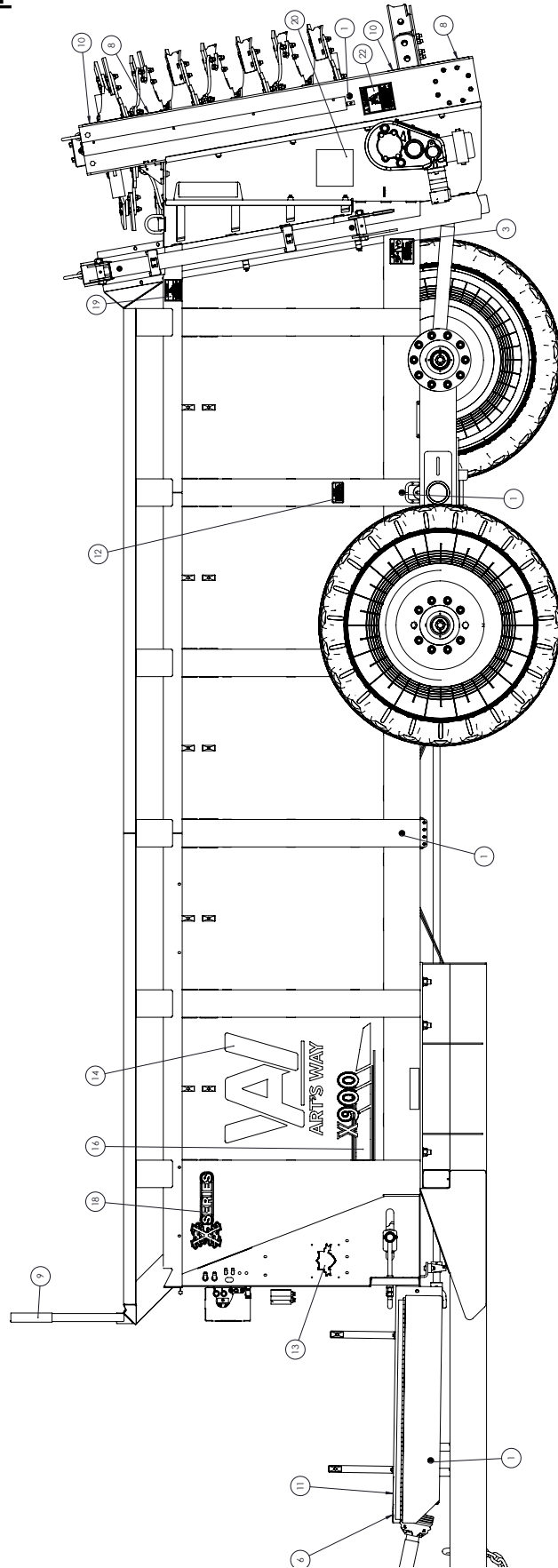

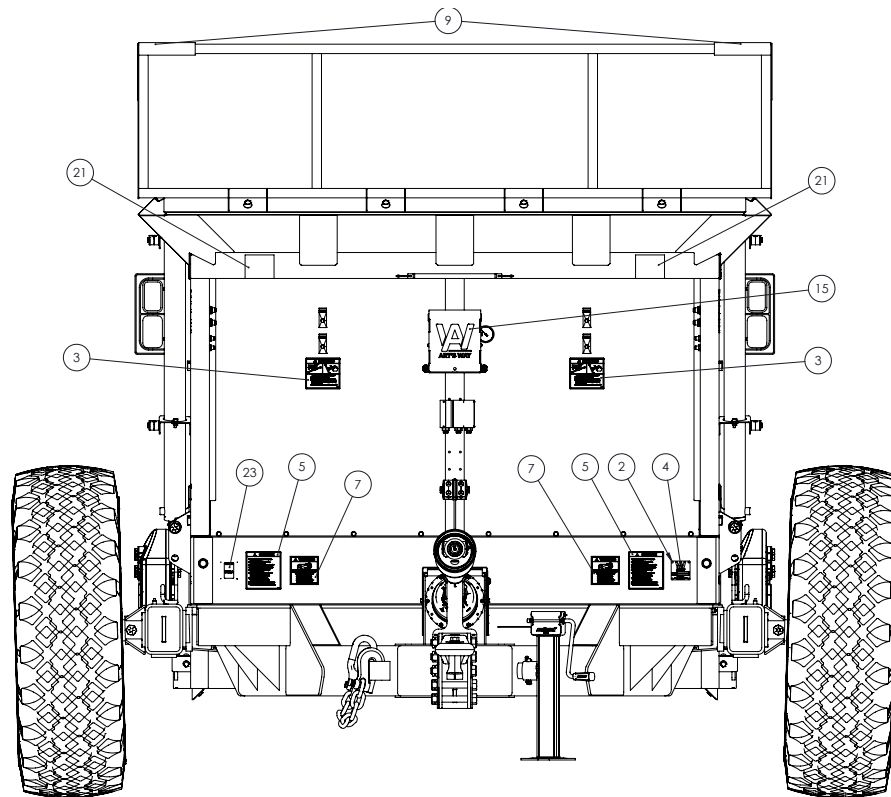

ITEM NO.	PART NUMBER	DESCRIPTION	QTY.
1	146670	DECAL, GREASE SYMBOL	6
2	204510	NAIL, 1/4" GRIP	4
3	346310	DECAL, WARNING HIGH PRESSURE	4
4	355605	TAG, SERIAL NUMBER PLATE	1
5	368040	DECAL, WARNING MOVING PART	2
6	384020	DECAL, DANGER 1050 RPM	1
7	467455	DECAL, WARNING	2
8	476450	TAPE, RED RETROREFLECTIVE	4
9	476460	TAPE, YELLOW RETROREFLECTIVE	6
10	476470	TAPE, RED-ORANGE FLORESCENT	4
11	487730	DECAL, DANGER	1
12	597390	DECAL, NOTICE	2
13	608085	DECAL, MADE IN AMERICA	2
14	720100	DECAL, NEW ARTS WAY LOGO	2
15	720120	DECAL, NEW ARTS WAY LOGO	1
16	720820	DECAL, X900, LH	1
17	720825	DECAL, X900, RH	1
18	720830	DECAL, "X" SERIES	2
19	720855	DECAL, WARNING	2
20	HJ22-00-0080	DECAL, DANGER	2
21	HJ22-00-0091	DECAL, DANGER	2
22	HJ22-00-0114	DECAL, DANGER	2
23	K18534203	DECAL, FEMA	1

SCALE ASSEMBLY (ALL)

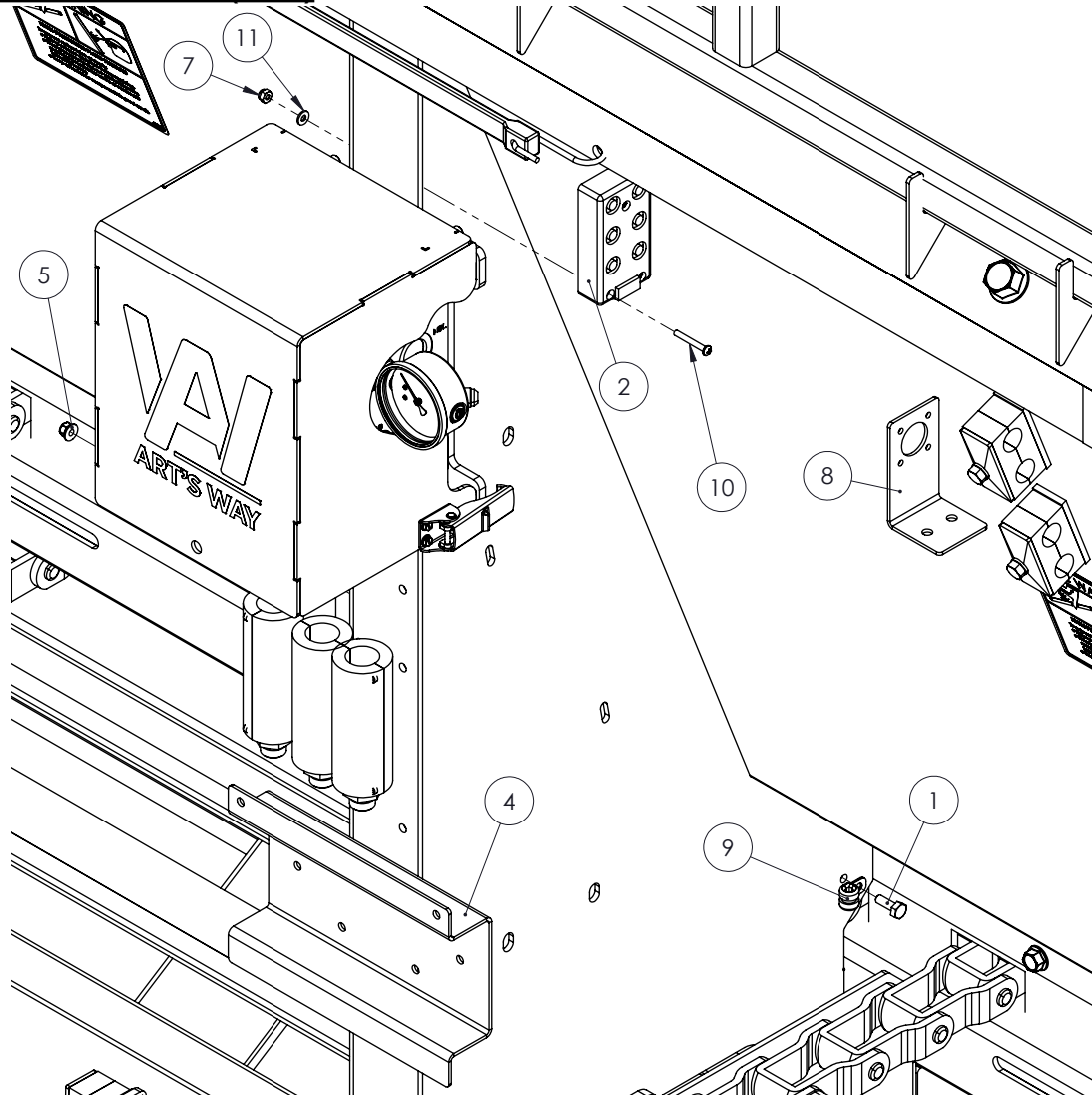

ITEM NO.	PART NUMBER	DESCRIPTION	QTY.
1	012051 *	BOLT, HHCS 1/4-20 X 3/4	1
2	597430 *	407659 J-BLOCK KIT	1
	597440 *	146698 10' CABLE	1
	597450 *	840459 MOUNTING BRACKET	1
	691046 *	408473 30' CABLE	4
NOT SHOWN	597440 *	146698 10' CABLE	1
4	597450 *	840459 MOUNTING BRACKET	1
5	600100 *	NUT, HFH NYLOC 1/4-20	1
NOT SHOWN	691046 *	408473 30' CABLE	4
7	710802 *	NUT, LOCK #8-32 NYLOCK	3
8	H200126 *	BULKHEAD MOUNT	1
9	HJ14-00-0142 *	CLAMP, 1/4"	1
10	P98315 *	SCREW, RHMS 8-32 X 1-1/4	3
11	P99544 *	WASHER, FLAT 8-32 ZN	3
PART NUMBERS WITH * AFTER ARE ON SCALED UNITS ONLY			

SCALE ASSEMBLY (RAVEN ONLY)

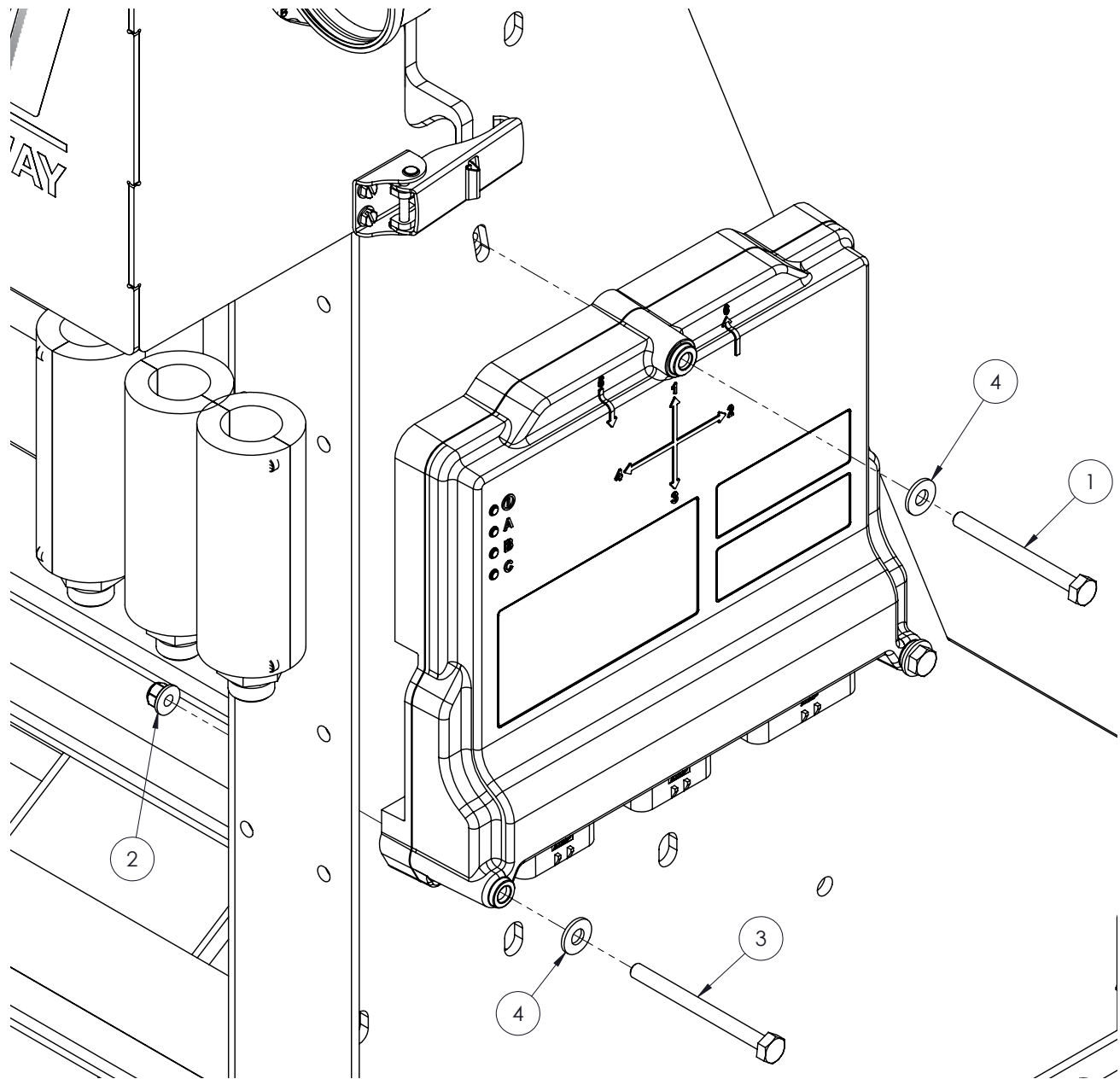

ITEM NO.	PART NUMBER	DESCRIPTION	QTY.
1	031560 *	BOLT, HHCS 1/4-20 X 2-1/2	1
2	600100 *	NUT, HFH NYLOC 1/4-20	3
3	G146609 *	BOLT, HHCS 1/4-20 X 3	2
4	I120392 *	WASHER, FLAT 5/16	3
PART NUMBERS WITH * AFTER ARE ON SCALED UNITS ONLY			

SCALE DIAGRAM (GT400)

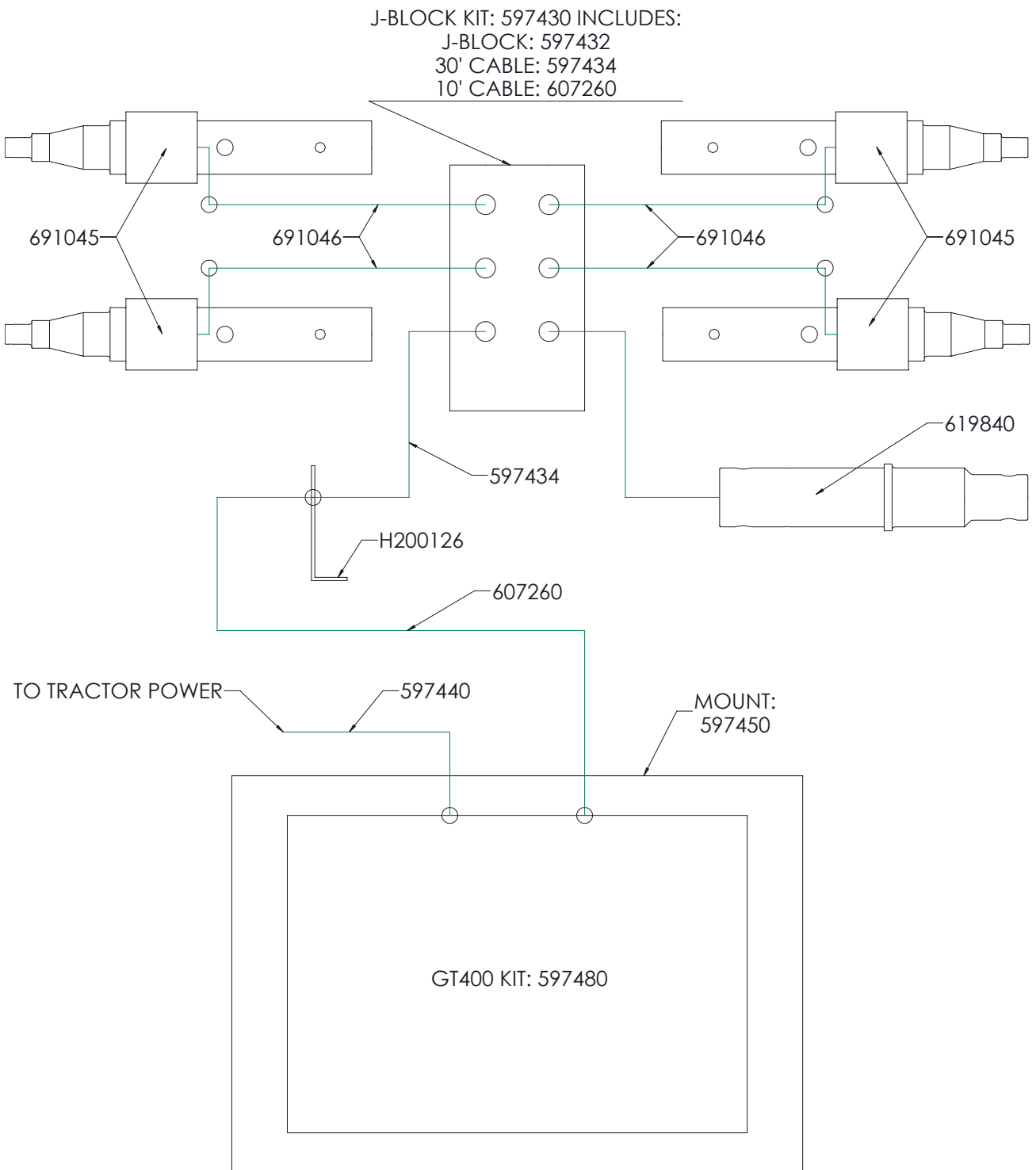

SCALE DIAGRAM (NT560)

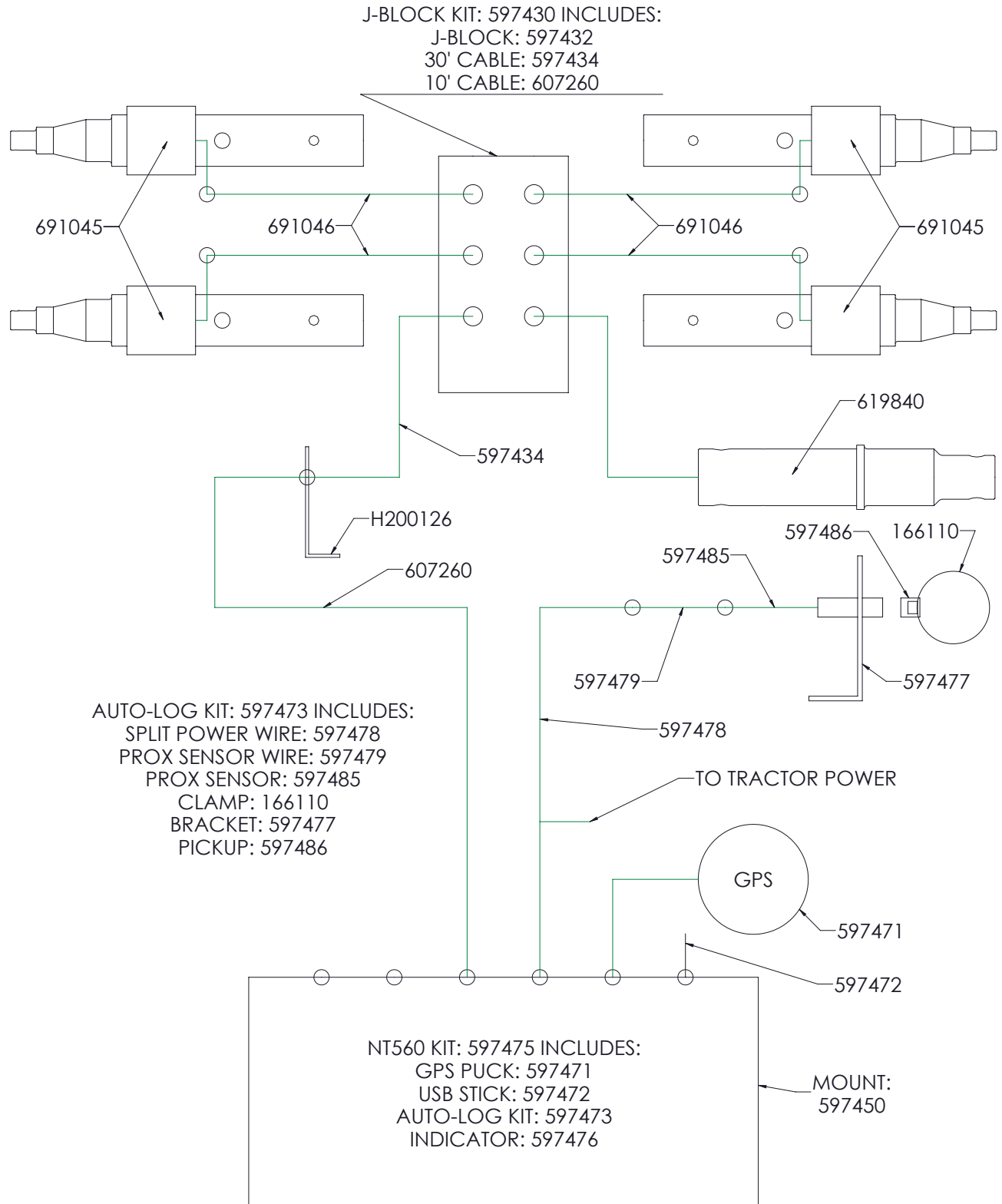

SCALE DIAGRAM (RAVEN RCM-LVL3 ISOBUS)

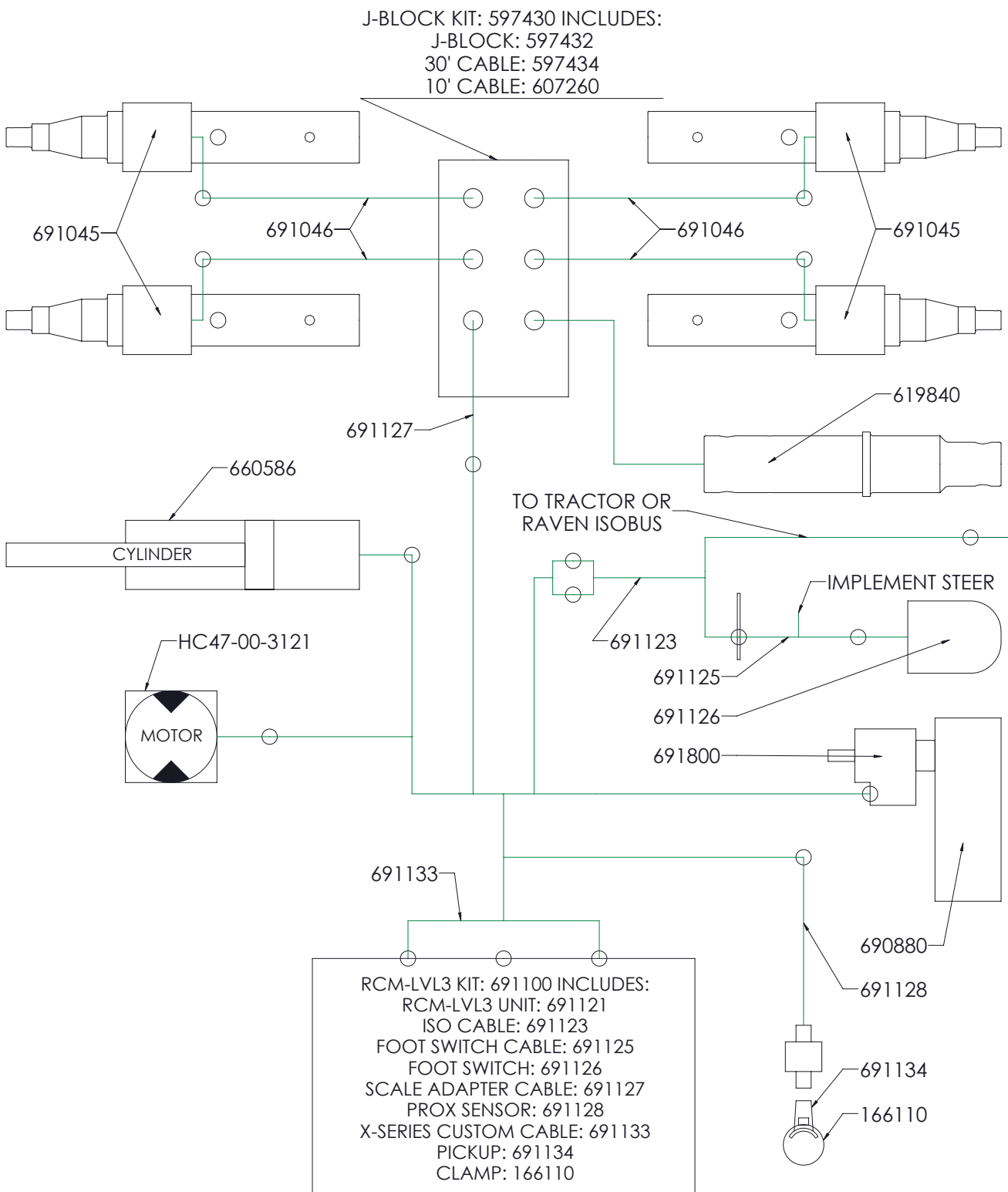

SCALE DIAGRAM (RAVEN ISOBUS CR7 INDICATOR & GPS)

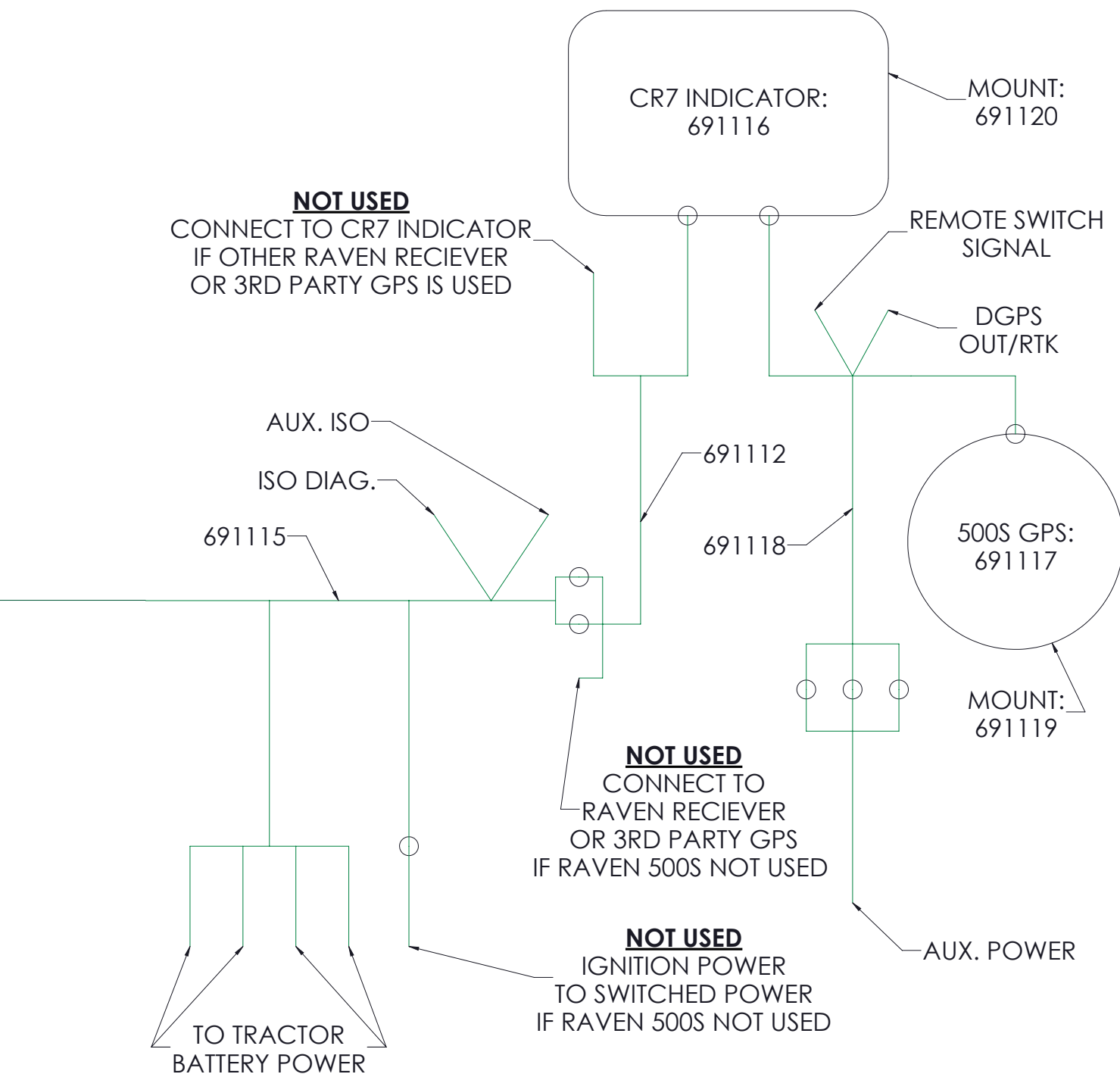

CR7 INDIC. & 500S GPS KIT: 691111 INCLUDES:
 CR7 INDICATOR: 691116
 500S GPS: 691117
 INDIC. TO GPS CABLE: 691118
 500S MOUNT: 691119
 CR7 RAM MOUNT: 691120

NOTES:



NOTES:





Art's Way Manufacturing TECHNICAL MANUALS

Manuals are available from your local dealer or Art's Way Manufacturing for the operation, service, and repair of your machine. For prompt convenient service, contact your local dealer for assistance in obtaining the manuals for your machine.

Manuals are also available at WWW.ARTSWAY.COM free to download for your convenience.

Always give the Machine Name, Model, and Serial Number so your local dealer can provide the correct manuals for your machine.

Art's Way Manufacturing reserves the right to make improvements in design or changes in specifications at any time without incurring any obligation to install them on units previously sold.

Except as expressly authorized, no part of this manual may be reproduced, copied, transmitted, or disseminated, in any storage medium, for any purpose without the express prior written consent of Art's Way Manufacturing

Art's Way Manufacturing
Armstrong, Iowa, 50514, (712) 208-8467.

WWW.ARTSWAY.COM