



Art's-Way Manufacturing Co., Inc.

Portable Grain Auger
8, 10, 12, And 14 Inch

Operator's Manual
SD205153

Issued August 2013



*This symbol means **ATTENTION! BECOME ALERT! YOUR SAFETY IS INVOLVED.** The message that follows the symbol contains important information about your safety. Carefully read the message. Make sure you fully understand the causes of possible injury or death.*

IF THIS MACHINE IS USED BY AN EMPLOYEE, IS LOANED, OR IS RENTED, MAKE SURE THAT THE OPERATOR UNDERSTANDS THE TWO INSTRUCTIONS BELOW.

BEFORE THE OPERATOR STARTS THE ENGINE:

1. GIVE INSTRUCTIONS TO THE OPERATOR ABOUT SAFE AND CORRECT USE OF THE MACHINE.
2. MAKE SURE THE OPERATOR READS AND UNDERSTANDS THE OPERATOR'S MANUAL FOR THIS MACHINE.

WARNING

IMPROPER OPERATION OF THIS MACHINE CAN CAUSE INJURY OR DEATH.

BEFORE STARTING THE ENGINE, DO THE FOLLOWING:

1. READ THE OPERATOR'S MANUAL.
2. READ ALL SAFETY DECALS ON THE MACHINE.
3. CLEAR THE AREA OF OTHER PERSONS.

LEARN AND PRACTICE SAFE USE OF MACHINE CONTROLS IN A SAFE AND CLEAR AREA BEFORE YOU OPERATE THIS MACHINE ON A JOB SITE.

It is your responsibility to observe pertinent laws and regulations and to follow manufacturer's instructions on machine operation and maintenance.

See your Authorized Art's-Way Manufacturing Co., Inc. dealer or Art's-Way Manufacturing Co., Inc. for additional operator's manuals, illustrated parts catalogs, and service manuals.

TO THE OWNER

Congratulations on the purchase of your new Art's-Way Portable Grain Auger. You have selected a top quality machine that is designed and built with pride to ensure you have many years of efficient and reliable service.

Many people have worked on the design, production, and delivery of this Portable Grain Auger. The information in this manual is based on the knowledge, study, and experience through years of specializing in the manufacturing of farm machinery. This manual is designed to provide you with important information regarding safety, maintenance, and machine operation so you can and will get the best possible performance from your Portable Grain Auger.

Even if you are an experienced operator of this or similar equipment, we ask that you ***read this manual before operating the Portable Grain Auger***. The way you operate, adjust, and maintain this unit will have much to do with its successful performance. Any further questions you may have about this product of Art's-Way equipment should be directed to your local Art's-Way dealer or to Art's-Way Manufacturing Co., Inc., Armstrong, Iowa, (712) 864-3131.

SPECIFICATIONS AND DESIGN ARE SUBJECT TO CHANGE WITHOUT NOTICE

Art's-Way Manufacturing Co., Inc. is continually making product improvements. In doing so, we reserve the right to make changes and/or add improvements to our products without obligation for the equipment previously sold.

Modifications to this Portable Grain Auger may affect the performance, function, and safety of its operation. Therefore, no modification are to be made without the written permission of Art's-Way Manufacturing Co., Inc. Any modification made without the written permission of Art's-Way Mfg. Co. shall void the warranty of this product.

In the interest of continued safe operation of this Portable Grain Auger, pay particular attention to the safety alert symbol(s) throughout this Manual.

ART'S-WAY MANUFACTURING CO., INC. STATEMENT OF PRODUCT LIABILITY

Art's-Way Manufacturing Co., Inc. recognizes its responsibility to provide customers with a safe and efficient product. Art's-Way Manufacturing Co., attempts to design and manufacture its products in accordance with all accepted engineering practices effective at the date of design. This statement should not be interpreted to mean that our products will protect against the user's own carelessness or failure to follow common safety practices nor will Art's-Way Manufacturing Co., be liable for any such act. In addition, Art's-Way Manufacturing Co. assumes no liability for any altered product or any modified product by users or anyone other than an authorized dealer.

IMPORTANT WARRANTY INFORMATION

The warranty for this Portable Grain Auger appears on page 5 of this manual. In order to establish proper warranty registration, the Warranty Registration must be completed and returned to the factory within 30 days. Failure to comply with this requirement may result in reduced warranty allowances.

LIMITATIONS OF THIS MANUAL

This manual contains operating instructions for your Portable Grain Auger only. Any mention of other machinery in this manual other than the Portable Grain Auger is for reference only. This manual does not replace nor is it to be used for any machinery that may be attached to or used in conjunction with the Portable Grain Auger.

PARTS & SERVICE

As the purchaser of your new Portable Grain Auger, it is very important to consider the following factors:

- A. Original Quality
- B. Availability of Service Parts
- C. Availability of Adequate Service Facilities

Art's-Way Manufacturing Co., Inc. has an excellent dealership network ready to answer any questions you may have about your Portable Grain Auger. Parts for your machine may be ordered through our dealers. When placing a parts order, please have the **model** and **serial number** ready. This will allow the dealer to fill your order as quickly as possible.

For your convenience, we have provided this space for you to record your model number, serial number, and the date of purchase, as well as your dealer's name and address.

Owner's Name: _____

Owner's Address: _____

Purchase Date: _____

Dealership Name: _____

Dealership Address: _____

Dealership Phone No.: _____

Machine Serial Number Location

The placard containing the serial and model number is located on the front left-hand side of the Portable Grain Auger.

Enter the serial number and model of your Portable Grain Auger within the space provided.

Building on a

Art's-Way

Tradition of Quality

SERIAL NO.

MODEL NO.

*Manufactured By
Art's-Way Manufacturing Co., Inc.
Armstrong, IA*

Figure 1 - Serial and Model Number Placard

TABLE OF CONTENTS

TO THE OWNER.....	1	OF FLOW INTO THE HOPPER IS NECESSARY.	38
SPECIFICATIONS AND DESIGN ARE SUBJECT TO CHANGE WITHOUT NOTICE	1	INTAKE SECTIONS	39
ART'S-WAY MANUFACTURING CO., INC. STATEMENT OF PRODUCT LIABILITY	1	WINCH AND CABLE.....	40
IMPORTANT WARRANTY INFORMATION.....	1	ART'S-WAY HYDRAULIC ALLY DRIVEN WORM WINCH	41
LIMITATIONS OF THIS MANUAL	1	<i>Worm Winch Break-In</i>	41
PARTS & SERVICE	2	<i>Lubrication</i>	41
TABLE OF CONTENTS	3	OPERATING INSTRUCTIONS	42
LIMITED WARRANTY	5	MOVING INSTRUCTIONS.....	43
SAFETY FIRST.....	6	CONNECT THE HYDRAULIC HOSE TO THE TRACTOR, RAISE/LOWER THE AUGER TO CLEAR ANY OBSTRUCTIONS.....	43
NOTICES OF DANGER, WARNING, AND CAUTION.....	6	HITCH ADJUSTMENT.....	43
SAFETY GUIDELINES.....	7	CYLINDER LIFT.....	44
BEFORE OPERATING	7	MAINTENANCE	45
DURING OPERATION	7	GENERAL MAINTENANCE PROCEDURE	45
MAINTENANCE SAFETY	7	<i>Intake Hopper Angle Drive</i>	45
HYDRAULIC SAFETY	7	<i>Hydraulic Hose</i>	45
TRANSPORTATION SAFETY	7	<i>Lift Cable</i>	45
OPERATING AND SAFETY EQUIPMENT	8	<i>Cable Sheaves</i>	45
SAFETY LABEL LOCATION	8	<i>Truss Cables</i>	45
SAFETY DECALS FOR AUGERS	9	<i>Wheel Hubs</i>	45
ASSEMBLY INSTRUCTIONS	12	<i>Tire Pressure</i>	45
8, 10 AND 12 INCH (34 FT) AUGERS.....	12	<i>Hopper Lift Cable</i>	45
8 INCH (46FT, 55FT, 60FT, 66FT, 72FT) AUGERS	13	<i>Hopper Lift Cable Pulleys</i>	45
10 INCH (55FT) AUGER.....	15	<i>Winch</i>	45
10 INCH 66 FT AND 76FT AUGERS	17	<i>Optional Low Profile Hopper</i>	45
10 INCH (62 FT, 72 FT AND 82 FT) AUGER.....	19	<i>PTO Driveline</i>	45
12 INCH (72, 82, AND 92FT) AUGER.....	24	SERVICING OF MECHANICAL DRIVE SYSTEMS	46
12 INCH (122FT) AUGER.....	27	<i>Bottom Chain Drive</i>	46
DRIVE.....	31	<i>Universal Joint</i>	46
PTO DRIVE ASSEMBLY	32	<i>Bearing</i>	46
ELECTRIC DRIVE ASSEMBLY	33	GEAR BOX	46
GAS DRIVE ASSEMBLY	34	LUBRICATION.....	47
HYDRAULIC DRIVE ASSEMBLY.....	35	GROUND HUGGER HOPPER	47
10 INCH BIN HOPPER ASSEMBLY	36	TRACTOR TO MAIN AUGER	47
12 INCH BIN HOPPER ASSEMBLY	37	INTERNAL POWER SHAFT	47
SHEAR BOLT	38	GEAR BOX.....	47
WHEN THE SPECIFIED SIZE AND GRADE OF SHEAR BOLT SHEARS, IT IS THE OPERATOR'S WARNING THAT AN EXTREME CONDITION EXISTS AND THAT A REDUCTION		<i>Oil Level</i>	47
		<i>Oil Change Information</i>	47

TRANSPORT	48	<i>Power Source.....</i>	<i>53</i>
PRE-TRANSPORT.....	48	<i>Capacity.....</i>	<i>53</i>
TRANSPORTING.....	48	<i>SAE Bolt Identification.....</i>	<i>53</i>
STORAGE	49	ART'S-WAY MANUFACTURING CO., INC.	
GOING TO STORAGE	49	TECHNICAL MANUALS	56
RETURNING TO SERVICE FROM STORAGE	49		
TROUBLE SHOOTING	50		
TORQUE SPECIFICATIONS.....	51		
TIGHTEN HYDRAULIC FITTINGS	52		
TIGHTENING FLARE TYPE FITTINGS.....	52		
TIGHTENING O-RING FITTINGS.....	52		
SPECIFICATIONS	53		
GENERAL	53		
<i>Model.....</i>	<i>53</i>		
<i>Height</i>	<i>53</i>		

LIMITED WARRANTY

Art's-Way Mfg. Co. warrants all new Portable Grain Auger covered by this agreement, when properly assembled, adjusted, and lubricated, to be free from defects in material and workmanship under normal use and service for which intended for a period of one (1) year from the date of delivery by the dealer. Date of delivery shall be the date product is placed in the possession of the user. **NORMAL WEAR FROM USE IS NOT A PART OF THIS WARRANTY.** Portable Grain Auger can be expected to have half (1/2) the wear life augering soybeans as opposed to augering corn or small grain. Art's-Way Mfg. Co. makes no warranty or representation, expressed or implied, on equipment including but not limited to gear box, winch, hydraulic motor, and implement input driveline, as all such parts are covered by the manufacturers own limited warranty.

TRAVEL COSTS ARE NOT COVERED IF THE DEALER IS REQUESTED BY THE USER TO TRAVEL TO ANOTHER LOCATION, HAUL, OR TOW THE MACHINE TO HIS SHOP FOR THE PURPOSE OF PERFORMING A WARRANTY OBLIGATION OR FREE INSPECTION. The Limited Warranty is extended to the original user only and is not transferrable to, nor enforceable by, any other person. Art's-Way Mfg. Co will replace free of charge any part of the product found to be defective when such part is returned to Art's-Way Mfg. Co, freight prepaid. If the part is found to be defective, Art's-Way Mfg. Co will refund freight charges paid by you in returning the defective part and prepay replacement part freight charges. Art's-Way Mfg. Co will not be responsible for more than replacement of any defective part and standard freight charges (parcel post or UPS ground rates) of any part found to be defective.

THIS IS THE EXCLUSIVE REMEDY, Art's-Way Mfg. Co SHALL NOT BE RESPONSIBLE OR LIABLE FOR ANY INCIDENTAL OR CONSEQUENTIAL DAMAGES RESULTING FROM ANY DEFECTS COVERED BY THIS WARRANTY OR ANY IMPLIED WARRANTY APPLICABLE TO THE PRODUCT INCLUDING BUT NOT LIMITED TO, PROPERTY DAMAGE, LOSS OF USE OF PRODUCT, LOSS OF TIME, LOSS OF PROFITS, INCONVENIENCE, COMMERCIAL LOSS, LABOR COSTS, SERVICE TRIPS, AND MILEAGE.

Some states do not allow the exclusion or limitation of incidental or consequential damages, so the above limitation or exclusion may not apply to you. This warranty shall not apply to any product or part of any product which has been altered elsewhere than at the place of manufacture.

ANY IMPLIED WARRANTIES APPLICABLE TO THE PRODUCT, INCLUDING IMPLIED WARRANTIES OR MERCHANTABILITY AND FITNESS FOR A PARTICULAR PURPOSE, ARE EXPRESSLY LIMITED IN DURATION TO THE TERM OF THE WARRANTY (ONE YEAR FROM THE DATE OF DELIVERY)

Some states do not allow limitation on how long an implied warranty lasts, so the above may not apply to you.

DEALER/DISTRIBUTOR WARRANTY CLAIM PROCEDURE

1. All warranty claims must be pre-approved by Art's-Way Mfg. Co. PRIOR to starting any warranty work. Warranty work performed without prior approval will not be considered.
2. All claims must be handled through dealer/distributor.
3. Written approval must be received from Art's-Way Mfg. Co. before return of merchandise. A Return Authorization is to be returned with the merchandise which is sent back.
4. All parts must be returned to Art's-Way Mfg. Co. at the address above, freight prepaid.
5. The serial number of the product and the date of delivery must accompany the parts being removed.
6. If the part is found to have failed because of defect in material or workmanship, replacement will be made on a no-charge basis and the part returned, freight prepaid. Standard freight charges (parcel post or UPS Ground rate) incurred in returning the defective part will be refunded.
7. For reasons of expediency, replacement and/or repair part may be shipped as soon as possible and billed to dealer/distributor. When part is returned, if it is covered under warranty, credit will be issued for part and freight charges.
8. All parts found to be defective shall be retained by and shall become property of Art's-Way Mfg. Co.

This warranty gives you specific legal rights, and you may also have other rights which vary from state to state

NOTE: NO WARRANTY ON USED TIRES.

Augers are farm equipment and are NOT TO BE TOWED AT HIGHWAY SPEEDS. Evidence of high speed towing WILL VOID WARRANTY.

SAFETY FIRST

“A careful operator is the best insurance against an accident”

(National Safety Council)

Most accidents can be prevented if the operator:

- Fully understands how the machine functions
- Can anticipate situations which may produce problems
- Can make necessary corrections before problems develop



**THIS SYMBOL MEANS
ATTENTION!
BECOME ALERT!
YOUR SAFETY IS INVOLVED!**

Figure 2 - Universal Safety Alert Symbol

The American Society of Agricultural Engineers has adopted the Universal Safety Alert Symbol as a way to identify areas of potential danger if the equipment is not operated correctly. Please be alert whenever you see this symbol in the manuals or on your forage box.

Art's-Way Manufacturing Co., Inc. strives to make our equipment as safe as possible. The Art's-Way Portable Grain Auger conforms to applicable safety standards at the time of manufacturing. A safety conscious equipment operator makes an effective accident-prevention program complete.

Safety features and instructions for the portable grain auger are detailed in the [Safety Guidelines](#) section of this Operator's Manual. It is the responsibility of the owner to ensure that all operators read and understand the manual before they are allowed to operate the portable grain auger. ([Occupational Safety and Health Administration \(OSHA\) regulations 1928.57.](#))

NOTICES OF DANGER, WARNING, AND CAUTION

Signal Words: Note the use of signal words **DANGER**, **WARNING**, and **CAUTION** on the portable grain auger and in this manual. The appropriate signal word for each has been selected using the following guidelines:



DANGER: IMMEDIATE AND SPECIFIC HAZARD WHICH WILL RESULT IN SEVERE PERSONAL INJURY OR DEATH IF PROPER PRECAUTIONS ARE NOT TAKEN.



WARNING: SPECIFIC HAZARD OR UNSAFE PRACTICE COULD RESULT IN SEVERE PERSONAL INJURY OR DEATH IF PROPER PRECAUTIONS ARE NOT TAKEN.



CAUTION: A REMINDER OF GOOD SAFETY PRACTICES. PERSONAL INJURY COULD RESULT IF PROPER PROCEDURES ARE NOT FOLLOWED.



SAFETY GUIDELINES



Remember:

“The Best Operator is a Safe Operator”



CAUTION: BEFORE YOU ATTEMPT TO OPERATE THIS PORTABLE GRAIN AUGER, READ AND STUDY THE FOLLOWING SAFETY INFORMATION. IN ADDITION, MAKE SURE THAT EVERY INDIVIDUAL WHO OPERATES OR WORKS WITH THIS EQUIPMENT, WHETHER FAMILY MEMBER OR EMPLOYEE, IS FAMILIAR WITH THESE SAFETY PRECAUTIONS. ART'S-WAY MFG. CO. PROVIDES GUARDS FOR EXPOSED MOVING PARTS FOR THE OPERATOR'S PROTECTION; HOWEVER, SOME AREAS CANNOT BE GUARDED OR SHIELDED IN ORDER TO ASSURE PROPER OPERATION. THE OPERATOR'S MANUAL AND DECALS ON THE MACHINE ITSELF WARN YOU OF DANGERS AND SHOULD BE READ AND OBSERVED CLOSELY.

CAUTION: SOME PHOTOGRAPHS USED HEREIN MAY SHOW DOORS, GUARDS AND SHIELDS OPENED AND REMOVED. BE SURE THAT ALL DOORS, GUARDS AND SHIELDS ARE FASTENED IN THEIR PROPER POSITION BEFORE MACHINE IS OPERATED.

BEFORE OPERATING

ELECTROCUTION HAZARD. The auger is not insulated. Keep away from overhead electrical wires and devices. Electrocution can occur without direct contact. **FAILURE TO KEEP AWAY WILL RESULT IN SERIOUS INJURY OR DEATH.**

Once in place, the auger should be anchored at the intake end and/or supported at the discharge end. The wheels should be chocked on both sides of auger and power source.

Do not attempt to increase auger height by positioning wheels on lumber, blocks, or by other means.

DO NOT alter or mount additional weight to the portable grain auger in any way that will cause an imbalance or overload in the unit. An overload or imbalance situation may result in a mechanical or structural failure of the lifting mechanism.

DURING OPERATION

Maximum elevation is determined by interference between track car and auger structure. The operator **MUST STOP RAISING** the auger **BEFORE** track car reaches the end of the track. Continued lift will cause failure to the winch, lift cable, or auger supports, causing

auger to collapse, resulting in **SERIOUS INJURY OR DEATH.**

On 12 and 14 inch (60 to 82 ft) augers, the operator **MUST STOP RAISING** the auger **BEFORE** extending member is fully extended. Continued lift will cause failure of the winch, lift cable, or auger supports, causing the auger to collapse, resulting in **SERIOUS INJURY OR DEATH.**

Keep all shields in place during operation.

MAINTENANCE SAFETY

After doing any service work, be sure to replace all shields and guards.

When ordering parts, please specify part number, length, and diameter of auger, type of drive, and serial number.

HYDRAULIC SAFETY

Never check for hydraulic leaks using any part of the human body. Oil injection can occur causing serious injury.

TRANSPORTATION SAFETY

Always transport the auger in the full down position. The lift arm of the undercarriage should be seated against the down position stop with slight tension on the winch cable and at least five (5) complete wraps of cable around the winch drum.

Never allow persons to stand underneath or ride on the auger when it's being transported.

Move the auger slowly into working position with towing vehicle and not by hand. Make certain everyone is clear of the work area.

UPENDING HAZARD – FAILURE TO FOLLOW THESE GUIDELINES MAY CAUSE UPENDING, WHICH MAY RESULT IN SERIOUS INJURY OR DEATH.

Never move the auger manually – use a vehicle.

Always have downward weight on the intake end of the auger.

Always test the downward weight before releasing the auger from the vehicle or holddown.

Always lift the intake slowly and keep it no higher than the tractor tow bar when attaching or releasing it.

Never push on the undercarriage.

Never move the auger with grain in the auger tube.

Always lower the auger to transport position before moving.

OPERATING AND SAFETY EQUIPMENT



CAUTION: BECOME FAMILIAR WITH AND KNOW HOW TO USE ALL SAFETY DEVICES AND CONTROLS BEFORE ATTEMPTING TO OPERATE THIS EQUIPMENT. KNOW HOW TO STOP THE UNIT BEFORE STARTING IT.

Art's-Way Mfg. Co. portable grain augers are designed primarily to convey grain to and from grain storage bins or buildings. This machine must have a break-in period with different operating conditions than for normal use. The tube and flighting must get a polished surface through use. Once the new auger has polished (some need 20 bushels and some need several hundred bushels) it will run smooth at recommended speed. Refer to Trouble Shooting on page 50.

During the break-in period, run the tractor at slow idle until the grain begins to flow from the discharge. For the first 500 bushels, operate at a slow speed and restrict the flow of grain at the intake. Gradually increase the speed until operating at full PTO speed. Do not run empty during break-in period.

After the break-in period, always operate at PTO speeds between 500 and 540 RPM (between 900 and 1000 RPM for some 12 inch models and 14 inch (55 ft and longer). Never run tractor at slow idle when full feeding the auger. Do not operate when empty as unnecessary wear occurs.

SAFETY LABEL LOCATION

Each portable grain auger has been produced and assembled with the operator's safety in mind. As a reminder to the operator of proper operation of the machine, several labels of warning and instruction have been attached. Information on labels is, by necessity less than in the operator's manual. Do not depend solely on the labels for safe and proper operation. Use your operator's manual.



CAUTION: DO NOT REMOVE ANY OF THESE LABELS. THEY ARE FOR YOUR PROTECTION. TAKE NOTE OF THEIR MESSAGES AND OBSERVE.

CAUTION: PERIODICALLY CHECK ALL LABELS AND REPLACE ANY THAT ARE MISSING, WORN, OR ILLEGIBLE. WHEN REPLACING, CLEAN MACHINE SURFACE THOROUGHLY USING SOAP AND WATER OR CLEANING SOLVENT TO REMOVE DIRT AND GREASE. CONTACT YOUR DEALER OR ART'S-WAY MFG. CO. IF ANY LABELS ARE NOT UNDERSTOOD.

CAUTION: THE PORTABLE GRAIN AUGER WAS DESIGNED AS A PORTABLE GRAIN AUGER. DO NOT USE FOR OTHER PURPOSES.

CAUTION: REPLACE ALL WORN, DAMAGED, UNUSABLE OR MISSING SAFETY SHIELDS AND GUARDS. CONTACT YOUR DEALER.

CAUTION: CLOSE OR REPLACE ALL COVERS, DOORS OR SHIELDS BEFORE STARTING THE PORTABLE GRAIN AUGER!

SAFETY DECALS FOR AUGERS



SD205536



SD205538



SD205535



SD205533



SD205541



SD205539

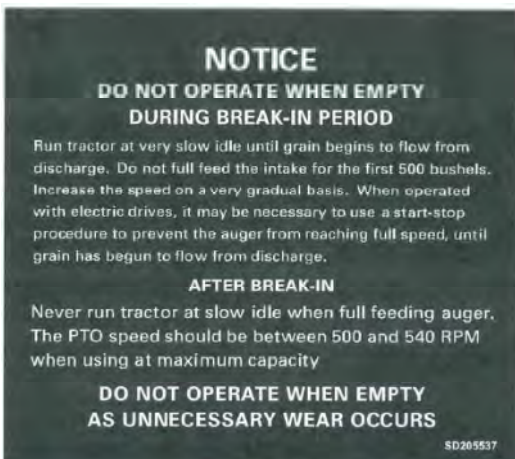

SD205537



SD205540

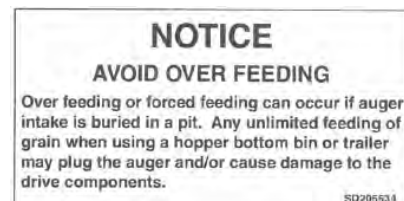

SD205534



346310



SD205629



467430



268860

Table 1 - PORTABLE GRAIN AUGER SAFETY DECALS

Ref No.	Part No.	Description
	SD205536	Decal – WARNING : Do not operate the unit before reading the operator’s manual
		Decal – NOTICE : Raising or lowering the auger with blocked or trapped wheels
	SD205537	Decal – NOTICE: Do not operate when empty during break-in period.
		Decal – WARNING : This auger transports over-height and over-width
		Decal – WARNING : Keep shield in place during operation
		Decal – NOTICE : Use a 3/8 inch diameter Grade 2 bolt
	SD205539	Decal – NOTICE : Use a 5/16 inch diameter Grade 2 bolt
		Decal – NOTICE : Use a 3/8 inch diameter Grade 5 bolt
	346310	Decal – WARNING : Hydraulic pressure
	SD205533	Decal – DANGER : Rotating flighting
		Decal – NOTICE : Auger worm winch
		Decal – Grease gun silhouette
	SD205538	Decal – WARNING : Contact with moving parts may result in injury or death
		Decal – NOTICE : Use a 1/4 inch diameter Grade 2 bolt
		Decal – NOTICE : Use a 5/16 inch diameter Grade 5 bolt
		Decal – DANGER : Shield missing
	SD205534	Decal – NOTICE : Avoid over feeding
	SD205631	Decal – STOP LIFT
	SD205624	Decal – NOTICE : Gear box must be checked for proper oil level
	SD205535	Decal – DANGER : Electrocutation Hazard
	SD205540	Decal – NOTICE : Do Not Tow Over 20 MPH
	SD205541	Decal – DANGER : Contact With Moving Parts

ASSEMBLY INSTRUCTIONS

8. 10 AND 12 INCH (34 FT) AUGERS

1. Clamp the intake cage to the tower tube. Be sure to have 1/2 inch clearance between the flight core and the bearing. Thrust load must be carried at the top of the auger.
2. Install track car onto the track (with the end containing the cable anchor towards the intake end of the auger) and install the 3/8 x 3/4 inch bolt in the end of the track.
3. Attach the brake winch to the mount on the underside of the lower tube using the 3/8 x 1 inch bolt, nut, and lock washer combination.
4. Add #90 gear lube to gear box until half full.
5. Assemble the undercarriage, as follows:
 - a. Attach the front support arms to the front undercarriage mount by sliding arms over the rod and inserting two (2) 3/16 x 1-1/2 inch cotter pins. Secure the arms by inserting a 3/8 X 1-1/2 inch bolt, nut, and lock washer combination into the cross bracing of the arms.
 - b. Attach the rear support arms to the track car by using two (2) 3/16 x 1-1/2 inch cotter pins. Secure the arms by inserting a 3/8 x 1 inch bolt, nut, and lock washer combination into the cross bracing.
 - c. Connect the rear arms to the front arms by lifting the auger tube, moving the rear arms until sleeves on all the arms line up. Slide the pivot rod through the arms and insert a 1 inch x 14 gauge bushing and a 1/4 x 2 inch cotter pin on each end of the rod.
 - d. Connect the axle to the front arms, using two (2) 3/8 x 3-3/16 inch U-bolts for each of the front arms. Mount the wheels.
6. Fasten the lift cable to the anchor on the lower side of the tube with a cable thimble and two (2) cable clamps, route the cable through the track car and fasten to the winch.

NOTE: The winch must be aligned with cable so that cable does not stack on one side of the drum. (See DANGER statement).



DANGER: WINCH MUST BE ALIGNED WITH CABLE SO THAT THE CABLE DOES NOT STACK ON ONE SIDE OF THE DRUM. DO NOT ALLOW THE CABLE TO BECOME SLACK ON WINCH DRUM. THE CABLE MAY RECOIL AND SLIP OVER THE SIDE OF THE DRUM. IN EITHER CASE, THE CABLE WILL WIND ON DRUM SPINDLE AND CAUSE THE WINCH OR CABLE TO FAIL, ALLOWING AUGER TO DROP, WHICH MAY CAUSE PHYSICAL DAMAGE TO THE AUGER OR MAY CAUSE PERSONAL INJURY.

7. Mount the Owner's Manual container to the winch mount. This is provided for the storage of the Owner's Manual and Assembly Instructions.
8. See separate assembly instructions for the different drive packages.
9. Refer to the Safe Operating Instructions on page 7.
10. There are several decals on the portable grain auger and its attachments with safety instructions, read and understand these safety alerts before operating. Also read and understand the Owner's Manual before operating.
11. Do not operate the auger empty during the break-in period. For the best results, do not full feed the intake for the first 500 bushels. After break-in, never run auger at slow idle when full feeding the auger.
12. See the drives section of this manual for the assembly instructions for the chosen drive.

8 INCH (46FT, 55FT, 60FT, 66FT, 72FT) AUGERS

1. Lay the top and lower auger tubes flat with the center joint spaced two feet apart
2. Fasten the flighting assemblies with two 3/8" x 2-1/2" fine thread bolts and locknuts be sure the lower flighting assembly overlaps the upper assembly For 866 and 872 models, the upper and center assemblies are already assembled, but the lower and center assemblies must be connected.
3. Be sure the top and the lower tubes are straight in line, slide the tubes together and connect the flange rings with the 1/2" x 1-1/2" bolts and locknuts.
NOTE: Do not fully tighten the bolts on one side the first time. Work around the flange at least twice to gradually pull the connection together. Fully tightening the bolts on one side will pull the auger tubes out of alignment. Be sure the driveline couplers have all 3 pins lined up when joining the tubes. Install the driveline shield channel, and driveline shield extensions.
4. Clamp the intake cage to the lower tube using six 3/8" x 1-1/2" bolts and locknuts. Leave 1/2" clearance between the flight core and wood intake cage bearing. **NOTE:** Thrust load must be carried at the top of the auger.
5. Mount the drop spout with two 3/8" x 1-1/4" bolts and locknuts and half clamp.
6. Attach the stop flags to the stop flag arms using the #10 x 3/4 inch screw and lock nuts. The lettering must face the auger tube when the arms are parallel to the tube. These flags will swing out when the track car approaches the end of the track.

NOTE: The operator must stop raising the auger when these swing out (See DANGER statement near SAFE OPERATING INSTRUCTIONS and recommendations).

7. Add No. 90 gear lube to the gearbox until 1/2 full.
8. Assemble the truss risers, as shown, using two supports, two 3/8 x 1 inch bolts, and lock nuts, one cross brace, and two 3/8 inch x 1-1/4 inch bolts and lock nuts. Mount the truss riser assemblies on the mounts located on the tubes using a 3/8 x 1 inch bolts and lock nuts. **DO NOT TIGHTEN THE NUTS TO ALLOW ROOM TO STIRNG THE CABLES IN STEP 9.**
9. 8-46 and 8-55
Install the 1/4" dia. truss cables using two cable clamps and one cable thimble on each upper cable end. Be sure to run the cable

through the truss riser assemblies as shown. Tighten the cables with the eyebolts on the lower cable ends to keep the auger straight, and tighten the bolts in the truss risers.

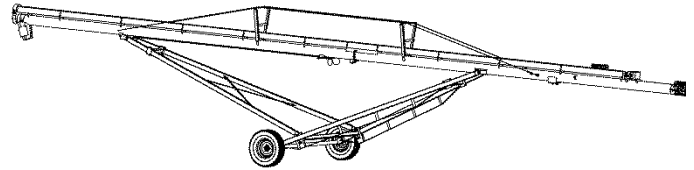

8-55 Model shown

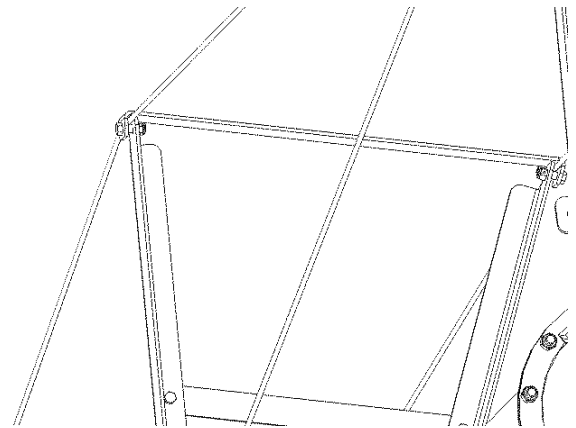

8-60, 8-66 and 8-72 models

Install 4 upper cables (SD200820). Begin by attaching the eyebolt to the lower tube at reference point 1. Install a 3/8" locknut on the eyebolt as far as you can turn it by hand, you will later use this to tension the cable. String the cable over the bolt holding the top brace to the side angle at reference points 2 and 3. Attach the cable anchor with a 25 degree angle (SD205436) to the base of the truss riser at reference point 4 using the same 3/8 inch x 1-1/4 inch bolts and lock nuts that attach the truss riser angles. Install a 1/4" cable thimble through the hole in the cable anchor sd205346, and route the cable through it. With the truss risers perpendicular to the tube pull the cable as tight as you can by hand and clamp them back to the cable using two 1/4" cable clamps MP900143. For maximum holding, be sure to install the clamps so the short tail presses against the U-bolt. Slide one clamp as tight to the thimble as possible and slide the other one to within 1" of the tail. If the tail is more than 24" long, cut the excess cable off. Repeat the process for the opposite side. Then attach the second set of cables beginning with attaching the "L" shaped eyebolt truss anchor bars to the base of the lowest truss riser (reference point 5) and routing through points 6 and 7 terminating at the anchor point welded to the tube at reference point 8 using a thimble and clamps. Tighten the cables with the eyebolts on the lower cable ends to keep the auger straight, and tighten the bolts in the truss risers.

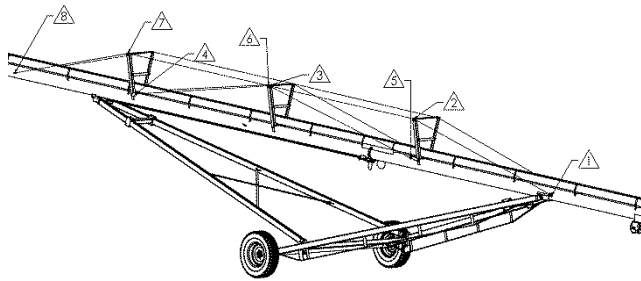

8-72 Model shown

10. Install the track car, with the opening on the sheave pointing toward the intake end of the auger, onto the top end of the track, and then install the $\frac{1}{2}$ " x 8" track stop bolt prior to using the auger. Failure to do so could cause the auger to collapse. Install all items this step before tightening any bolts.
 - a. Attach the rear lift arms to the track car using one $\frac{1}{2}$ x 8 inch bolt, one locknut, and two washers.
 - b. Attach the front lift arms to the front undercarriage mount on the lower tube using one $\frac{5}{8}$ x 1- $\frac{1}{2}$ inch bolt, bushing, washer, and nut for each arm.
 - c. Install the cross-brace weldment using six $\frac{5}{8}$ x 1- $\frac{1}{2}$ inch bolts and nuts. Leave the top hole on each side open.
 - d. Connect the rear arms to the front arms and cross-brace weldment by lifting the auger tube, moving the rear arms so that the top holes on the cross-brace and the holes in the rear arms line up. Attach the rear arms using $\frac{5}{8}$ x 2 inch bolt, bushings, washer, and nut for each arm.
 - e. Attach the axle using six $\frac{5}{8}$ x 1- $\frac{1}{2}$ inch bolts and lock nuts.
 - f. Install the front cross-brace weldment using eight $\frac{1}{2}$ x 1- $\frac{1}{2}$ inch bolts, and lock nuts.
 - g. Install the two rear X-braces using five $\frac{1}{2}$ x 1- $\frac{1}{2}$ inch bolts, and lock nuts.
11. Mount the wheels. Align the tube so that it's centered over the undercarriage and level before tightening the bolts installed in Step 8. Tighten the bolts at each joint on the left and right side before going to the next joint to avoid the undercarriage pulling to one side by tightening all the bolts on one side first. Install the rear undercarriage arm cross-brace using eight $\frac{1}{2}$ " x 3- $\frac{1}{2}$ " bolts and locknuts and two 5" x 6" rectangular plates. (rear undercarriage arm cross-brace is not used on 8-46 models)
12. Mount the winch onto the winch mount located on the lower tube using $\frac{3}{8}$ x 1 inch bolts washers and lock nuts.

8-46 model

Fasten the lift cable to the anchor on the lower side of the upper tube with a cable thimble and two (2) cable clamps, route the cable through the track car and fasten to the winch.

8-55, 8-60, 8-66 and 8-72 models

Fasten the lift cable to the pin under the cable sheave in the track car with two cable clamps. Thread the cable through sheave by the tube splice, back around and through the sheave in the track car and fasten to the winch.
13. Refer to the Safe Operating Instructions on page 7.
14. There are several decals on the portable grain auger and its attachments with safety instructions, read and understand these safety alerts before operating. Also read and understand the Owner's Manual before operating.
15. Do not operate the auger empty during the break-in period. For the best results, do not full feed the intake for the first 500 bushels. After break-in, never run auger at slow idle when full feeding the auger.
16. See the drives section of this manual for the assembly instructions for the chosen drive.

10 INCH (55FT) AUGER

1. Lay the top and lower auger tubes flat with the center joint spaced two feet apart
2. Fasten the flighting assemblies with two 1/2" x 3" fine thread bolts and locknuts be sure the lower flighting assembly overlaps the upper assembly.
3. Be sure the top and the lower tubes are straight in line, slide the tubes together and connect the flange rings with the 1/2" x 1-1/2" bolts and locknuts.
NOTE: Do not fully tighten the bolts on one side the first time. Work around the flange at least twice to gradually pull the connection together. Fully tightening the bolts on one side will pull the auger tubes out of alignment. Be sure the driveline couplers have all 3 pins lined up when joining the tubes. Install the driveline shield channel, and driveline shield extensions.
4. Clamp the intake cage to the lower tube using six 3/8" x 1-1/2" bolts and locknuts. Leave 1/2" clearance between the flight core and wood intake cage bearing. **NOTE:** Thrust load must be carried at the top of the auger.
5. Mount the drop spout with two 3/8" x 1-1/4" bolts and locknuts and half clamp.

6. Attach the stop flags to the stop flag arms using the #10 x 3/4 inch screw and lock nuts. The lettering must face the auger tube when the arms are parallel to the tube. These flags will swing out when the track car approaches the end of the track.

NOTE: The operator must stop raising the auger when these swing out (See DANGER statement near SAFE OPERATING INSTRUCTIONS and recommendations).

7. Check the gearbox for lube, add No. 90 gear lube to the gearbox until 1/2 full.
8. Assemble the truss risers, as shown, using two supports, two 3/8 x 1 inch bolts, and lock nuts, one cross brace, and two 3/8 inch x 1-1/4 inch bolts and lock nuts. Mount the truss riser assemblies on the mounts located on the tubes using a 3/8 x 1 inch bolts and lock nuts. **DO NOT TIGHTEN THE NUTS TO ALLOW ROOM TO STIRNG THE CABLES IN STEP 9.**
9. Install the 1/4" dia. truss cables using two cable clamps and one cable thimble on each upper cable end. Be sure to run the cable through the truss riser assemblies as shown. Tighten the cables with the eyebolts on the lower cable ends to keep the auger straight, and tighten the bolts in the truss risers.

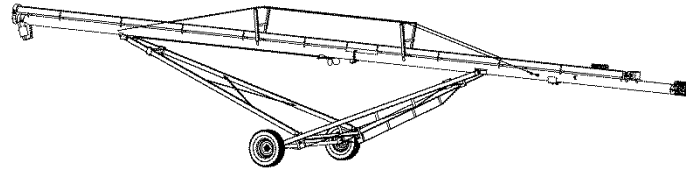

10. Install the track car, with the opening on the sheave pointing toward the intake end of the auger, onto the top end of the track, and then install the 1/2" x 8" track stop bolt prior to using the auger. Failure to do so could cause the auger to collapse. Install all items this step before tightening any bolts.
 - a. Attach the rear lift arms to the track car using one 1/2 x 8 inch bolt, one locknut, and two washers.
 - b. Attach the front lift arms to the front undercarriage mount on the lower tube using one 5/8 x 1-1/2 inch bolt, bushing, washer, and nut for each arm.
 - c. Install the cross-brace weldment using six 5/8 x 1-1/2 inch bolts and nuts. Leave the top hole on each side open.
 - d. Connect the rear arms to the front arms and cross-brace weldment by lifting the auger tube, moving the rear arms so that the top holes on the cross-brace and the holes in the rear arms line up. Attach the rear arms using 5/8 x 2 inch bolt, bushings, washer, and nut for each arm.
 - e. Attach the axle using six 5/8 x 1-1/2 inch bolts and lock nuts.
 - f. Install the front cross-brace weldment using eight 1/2 x 1-1/2 inch bolts, and lock nuts.
 - g. Install the two rear X-braces using five 1/2 x 1-1/2 inch bolts, and lock nuts.
11. Mount the wheels. Align the tube so that it's centered over the undercarriage and level before tightening the bolts installed in Step 8. Tighten the bolts at each joint on the left and right side before going to the next joint to avoid the undercarriage pulling to one side by tightening all the bolts on one side first. Install the rear undercarriage arm cross-brace using eight 1/2" x 3-1/2" bolts and locknuts and two 5" x 6" rectangular plates. (rear undercarriage arm cross-brace is not used on 8-46 models)

12. Mount the winch onto the winch mount located on the lower tube using 3/8 x 1 inch bolts washers and lock nuts. Fasten the lift cable to the pin under the cable sheave in the track car with two cable clamps. Thread the cable through sheave by the tube splice, back around and through the sheave in the track car and fasten to the winch.
13. Refer to the Safe Operating Instructions on page 7.
14. There are several decals on the portable grain auger and its attachments with safety instructions, read and understand these safety alerts before operating. Also read and understand the Owner's Manual before operating.
15. Do not operate the auger empty during the break-in period. For the best results, do not full feed the intake for the first 500 bushels. After break-in, never run auger at slow idle when full feeding the auger.
16. See the drives section of this manual for the assembly instructions for the chosen drive.

10 INCH 66 FT AND 76FT AUGERS

1. Lay the top and lower auger tubes flat with the center joint spaced two feet apart
2. Fasten the flighting assemblies together with two fine thread 1/2" x 3" bolts and locknuts. Fasten the flighting assemblies so that the lower assembly overlaps the upper assembly.
3. Be sure the top and the lower tubes are straight in line, slide the 2-1/2" x 12" PVC tubing around the driveline on the lower end of the top tube, this will shield the coupler once the auger is assembled. Connect the drivelines with the keyed driveline coupler, install the key and drive a 1/4" x 2-1/4" roll pin through the coupler between the drivelines. Slide the tubes together and connect the flange rings with the 1/2" x 1-1/2" bolts and locknuts.
NOTE: Do not fully tighten the bolts on one side the first time. Work around the flange at least twice to gradually pull the connection together. Fully tightening the bolts on one side will pull the auger tubes out of alignment. Tighten the setscrews in the driveline coupler, and slide the PVC tubing shield over the coupler. Install the driveline shield channel over the splice.
4. Clamp the intake cage to the lower tube using six 3/8" x 1-1/2" bolts and locknuts. Leave 1/2" clearance between the flight core and wood intake cage bearing. **NOTE:** Thrust load must be carried at the top of the auger.
5. Mount the drop spout with two 3/8" x 1-14" bolts and locknuts and half clamp.
6. Attach the stop flags to the stop flag arms using the #10 x 3/4 inch screw and lock nuts. The lettering must face the auger tube when the arms are parallel to the tube. These flags will swing out when the track car approaches the end of the track.

NOTE: The operator must stop raising the auger when these swing out (See DANGER statement near SAFE OPERATING INSTRUCTIONS and recommendations.

7. Add No. 90 gear lube to the gearbox until 1/2 full.
8. Assemble the truss risers, as shown, using two supports, two 3/8 x 1 inch bolts, and lock nuts, one cross brace, and two 3/8 inch x 1-1/4 inch bolts and lock nuts. Mount the truss riser assemblies on the mounts located on the tubes using a 3/8 x 1 inch bolts and lock nuts. **DO NOT TIGHTEN THE NUTS TO ALLOW ROOM TO STIRNG THE CABLES IN STEP 9.**
9. Install the 2 lower cables (on the 10-76 only) and 4 upper cables (on the 10-66 and 10-76 models) as shown. Begin by installing the eyebolt

attached to the cable in the anchor channel on the tube at reference point 1. Install a 3/8" locknut on the eyebolt as far as you can turn it by hand, you will later use this to tension the cable. String the cable over the bolt holding the top brace to the side angle at reference points 2 and 3. Attach the cable anchor with a 25 degree angle (SD205436) to the base of the truss riser at reference point 4 using the same 3/8 inch x 1-1/4 inch bolts and lock nuts that attach the truss riser angles. Install a 1/4" cable thimble through the hole in the cable anchor sd205346, and route the cable through it. With the truss risers perpendicular to the tube pull the cable as tight as you can by hand and clamp them back to the cable using two 1/4" cable clamps MP900143. For maximum holding, be sure to install the clamps so the short tail presses against the U-bolt. Slide one clamp as tight to the thimble as possible and slide the other one to within 1" of the tail. If the tail is more than 24" long, cut the excess cable off. Repeat the process for the opposite side. Then attach the second set of cables beginning with attaching the "L" shaped eyebolt truss anchor bars to the base of the lowest truss riser (reference point 5) and routing through points 6 and 7 terminating at the anchor point welded to the tube at reference point 8 using a thimble and clamps. Repeat for the opposite side. Ensure that the truss risers are square with the tube and tighten the bolts, then tighten the nuts on the eyebolts so that the tension on all cables is even and the tube is just slightly bowed up. On 10-76 models repeat the procedure to install the lower truss cables (SD200809) beginning with the eyebolts at reference point 20 through 21 and anchoring to the tube at reference point 22. Tighten all bolts in the truss risers.

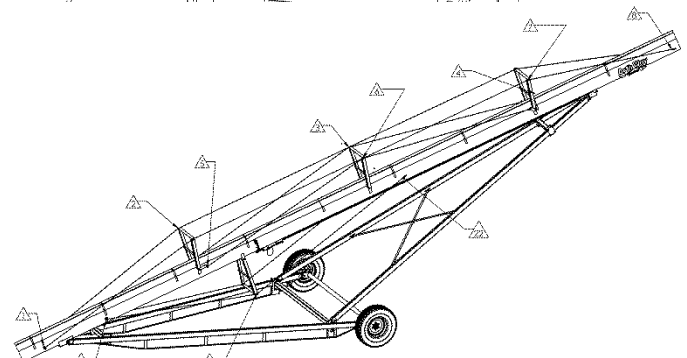
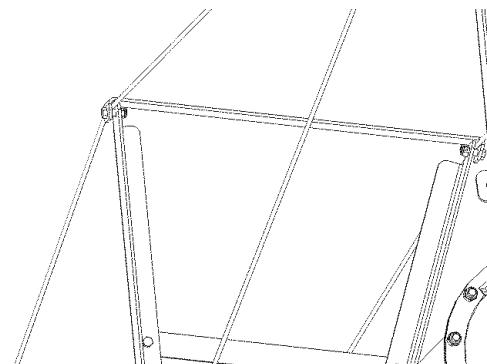

10-76 Model shown

10. Install the track car, with the opening on the sheave pointing toward the intake end of the auger, onto the top end of the track, and then install the ½" x 8" track stop bolt prior to using the auger. Failure to do so could cause the auger to collapse. Install all items this step before tightening any bolts.
 - a. Attach the rear lift arms to the track car using one 1/2 x 8 inch bolt, one locknut, and two washers.
 - b. Attach the front lift arms to the front undercarriage mount on the lower tube using one 5/8 x 1-1/2 inch bolt, bushing, washer, and nut for each arm.
 - c. Install the cross-brace weldment using six 5/8 x 1-1/2 inch bolts and nuts. Leave the top hole on each side open.
 - d. Connect the rear arms to the front arms and cross-brace weldment by lifting the auger tube, moving the rear arms so that the top holes on the cross-brace and the holes in the rear arms line up. Attach the rear arms using 5/8 x 2 inch bolt, bushings, washer, and nut for each arm.
 - e. Attach the axle using six 5/8 x 1-1/2 inch bolts and lock nuts.
 - f. Install the front cross-brace weldment using eight 1/2 x 1-1/2 inch bolts, and lock nuts.
 - g. Install the two rear X-braces using five 1/2 x 1-1/2 inch bolts, and lock nuts.
11. Mount the wheels. Align the tube so that it's centered over the undercarriage and level before tightening the bolts installed in Step 8. Tighten the bolts at each joint on the left and right side before going to the next joint to avoid the undercarriage pulling to one side by tightening all the bolts on one side first. Install the rear undercarriage arm cross-brace using eight 1/2" x 3-1/2" bolts and locknuts and two 5" x 6" rectangular plates.
12. Mount the winch onto the winch mount located on the lower tube using 3/8 x 1 inch bolts washers and lock nuts. Fasten the lift cable to the cable anchor near the splice in the tube with a thimble and two cable clamps. Route the cable through the opening above the sheave located under the tube. Continue around the top sheave in the track car, and go back to the middle of the auger, around the sheave, and back to the track car. Go through the bottom sheave on the track car and down fastening the end to the winch.
13. Refer to the Safe Operating Instructions on page 7.
14. There are several decals on the portable grain auger and its attachments with safety instructions, read and understand these safety alerts before operating. Also read and understand the Owner's Manual before operating.
15. Do not operate the auger empty during the break-in period. For the best results, do not full feed the intake for the first 500 bushels. After break-in, never run auger at slow idle when full feeding the auger.
16. See the drives section of this manual for the assembly instructions for the chosen drive.

10 INCH (62 FT, 72 FT AND 82 FT) AUGER

1. Lay the top and lower auger tubes flat with the center joint spaced two feet apart
2. Fasten the flighting assemblies together with two fine thread $\frac{1}{2}$ " x 3" bolts and locknuts. Fasten the flighting assemblies so that the lower assembly overlaps the upper assembly.
3. Lay the top and bottom (top and middle on 82' model) auger tubes flat with the center joint spaced two feet apart. Mount the 4-bolt cast flange bearing onto the discharge end of the top tube using 4 $\frac{1}{2}$ x 1-1/2 inch bolts and lock nuts. Fasten the flighting assemblies together with two fine thread nuts and bolts. Fasten the flighting assemblies so that the lower assembly overlaps the upper assembly. For the 10 inch (72 ft) models, the upper and center assemblies are already connected, but the center and lower assemblies must be connected.
4. Be sure the top and lower tubes are straight in line. Slide the tubes together and connect at flange rings using the $\frac{1}{2}$ x 1-1/2 inch bolts and lock nut.

NOTE: Do not fully tighten bolts in flange ring connection the first time. Work around the flange at least twice to gradually pull the connection together. Fully tightening the bolts on one side will pull the auger tubes out of alignment.

5. On the 82' auger repeat steps two, three and four so all 3 sections are assembled.
6. Assemble the truss risers, as shown, using two supports, two $\frac{3}{8}$ x 1 inch bolts, and lock nuts, one cross brace, and two $\frac{3}{8}$ inch x 1-1/4 inch bolts and lock nuts. Mount the truss riser assemblies on the mounts located on the tubes using a $\frac{3}{8}$ x 1 inch bolts and lock nuts. **DO NOT TIGHTEN THE NUTS TO ALLOW ROOM TO STIRNG THE CABLES IN STEP 7.**
7. Install the truss cables using two cable clamps and one cable thimble for each cable. Be sure to run the cables through the truss as shown.

On the 10 inch (62 ft) model: install 4 upper cables (SD200820). Begin by attaching the "L" shaped eyebolt truss anchor bars to the hopper lift mount with a $\frac{3}{8}$ x 1 inch bolt, and lock nut. Then install the eyebolt attached to the cable in the truss bar at reference point 1. Install a $\frac{3}{8}$ " locknut on the eyebolt as far as you can turn it by hand, you will later use this to tension the cable. String the cable over the bolt holding the top brace to the side angle at reference points 2 and 3. Attach the cable anchor with a 25 degree angle to the base of the truss riser at reference point 4 using the same $\frac{3}{8}$ inch x 1-1/4 inch bolts and lock nuts that attach the truss riser angles. Install a $\frac{1}{4}$ " cable thimble through the hole in the cable anchor, and route the cable through it. With the truss risers perpendicular to the tube pull the cable as tight as you can by hand and clamp them back to the cable using two $\frac{1}{4}$ " cable clamps MP900143. For maximum holding, be sure to install the clamps so the short tail presses against the U-bolt. Slide one clamp as tight to the thimble as possible and slide the other one to within 1" of the tail. If the tail is more than 24" long, cut the excess cable off. Repeat the process for the opposite side. Then attach the second set of cables beginning with attaching the "L" shaped eyebolt truss anchor bars to the base of the lowest truss riser (reference point 5) and routing through points 6 and 7 terminating at the anchor point welded to the tube at reference point 8 using a thimble and clamps. Repeat for the opposite side. Ensure that the truss risers are square with the tube and tighten the bolts, then tighten the nuts on the eyebolts so that the tension on all cables is even and the tube is slightly bowed up. Tighten all bolts on the truss risers.

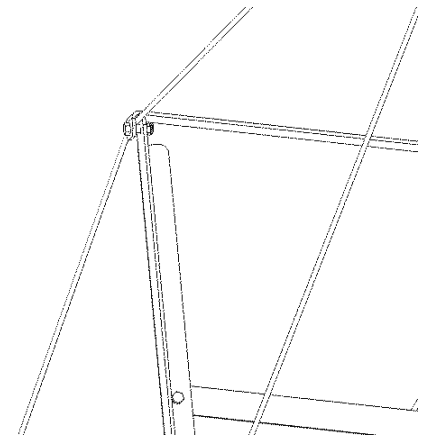
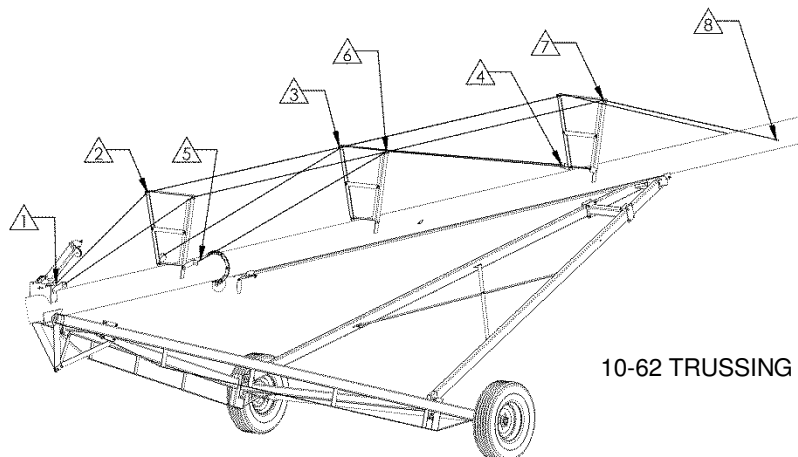

On the 10 inch (72 ft) model: install the 2 lower cables (SD200809) and 4 upper cables (SD200820) as shown below. Begin by installing the eyebolt attached to the cable in the anchor channel on the tube at reference point 1. Install a 3/8" locknut on the eyebolt as far as you can turn it by hand, you will later use this to tension the cable. String the cable over the bolt holding the top brace to the side angle at reference points 2 and 3. Attach the cable anchor with a 25 degree angle to the base of the truss riser at reference point 4 using the same 3/8 inch x 1-1/4 inch bolts and lock nuts that attach the truss riser angles. Install a 1/4" cable thimble through the hole in the cable anchor, and route the cable through it. With the truss risers perpendicular to the tube pull the cable as tight as you can by hand and clamp them back to the cable using two 1/4" cable clamps MP900143. For maximum holding, be sure to install the clamps so the short tail presses against the U-bolt. Slide one clamp as tight to the thimble as possible and slide the other one to within 1" of the tail. If the tail is more than 24" long, cut the excess cable off. Repeat the process for the opposite side. Then attach the second set of cables beginning with attaching the "L" shaped eyebolt truss anchor bars to the base of the lowest truss riser (reference point 5) and routing through points 6 and 7 terminating at the anchor point welded to the tube at reference point 8 using a thimble and clamps. Repeat for the opposite side. Ensure that the truss risers are square with the tube and tighten the bolts, then tighten the nuts on the eyebolts so that the tension on all cables is even and the tube is slightly bowed up. Repeat the procedure to install the lower truss cables (SD200809) beginning with the eyebolts at reference point 20 through 21 and anchoring to the tube at reference point 22. Tighten all bolts on the truss risers.

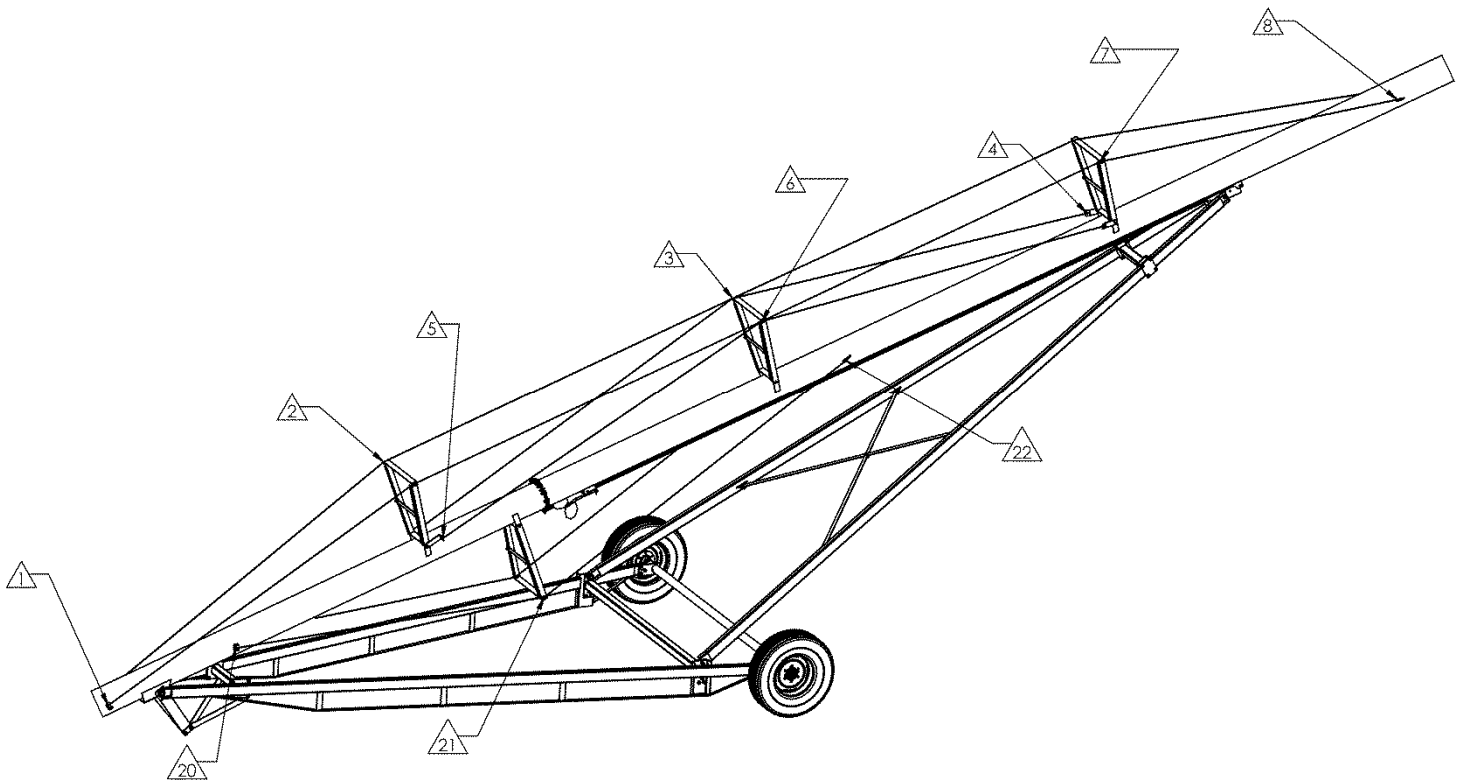

10-72 TRUSSING

On the 10 inch (82 ft) model: install the 2 lower cables (SD200809) and 8 upper cables (SD200820). Begin by attaching the “L” shaped eyebolt truss anchor bars to the hopper lift mount with two 3/8 x 1 inch bolts, and lock nuts. Then install the eyebolt attached to the cable in the truss bar at reference point 1. Install a 3/8” locknut on the eyebolt as far as you can turn it by hand, you will later use this to tension the cable. String the cable over the bolt holding the top brace to the side angle at reference points 2 and 3. Attach the cable anchor with a 25 degree angle to the base of the truss riser at reference point 4 using the same 3/8 inch x 1-1/4 inch bolts and lock nuts that attach the truss riser angles. Install a 1/4” cable thimble through the hole in the cable anchor, and route the cable through it. With the truss risers perpendicular to the tube pull the cable as tight as you can by hand and clamp them back to the cable using two 1/4” cable clamps. For maximum holding, be sure to install the clamps so the short tail presses against the U-bolt. Slide one clamp as tight to the thimble as possible and slide the other one to within 1” of the tail. If the tail is more than 24” long, cut the excess cable off. Repeat the process for the opposite side. Then attach the second set of cables begin by attaching the “L” shaped eyebolt truss anchor bars to the base of the lowest truss riser (reference point 5) and routing through points 6 and 7 terminating at the base of the truss riser using a cable anchor with a 25 degree angle at reference point 8 using a thimble and clamps. Then repeat attaching at points 9-12 and then at points 13-16 anchoring to the tube. Repeat for the opposite side. Ensure that the truss risers are square with the tube and tighten the bolts, then tighten the nuts on the eyebolts so that the tension on all cables is even and the tube is just slightly bowed up. Repeat the procedure to install the lower truss cables (SD200809) beginning with the eyebolts at reference point 20 through 21 and anchoring to the tube at reference point 22. Tighten all bolts on the truss risers.

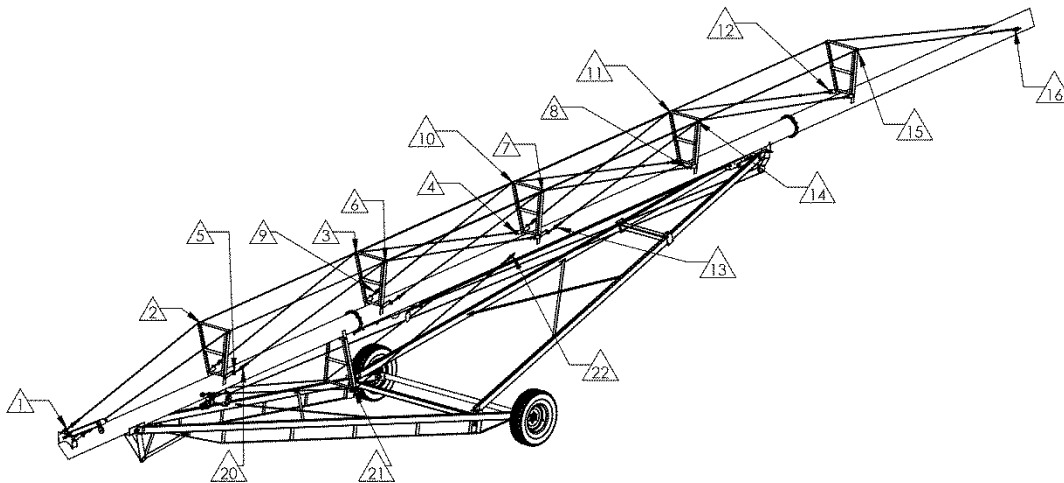

10-82 TRUSSING

8. Attach the drive section to the lower tube using the 1/2 x 1-1/2 inch bolts and lock nuts. Adjust the fighting discharge end shaft so the thrust is carried on the 4-bolt cast flange bearing by bottoming the fighting out on the splined shaft, then threading the 1-1/2 inch nut onto the fighting end shaft until finger tight. Then tighten the nut two more full turns. Do not let the fighting bottom out on the spline shaft at the intake end after adjustment. The thrust load must be carried at the discharge end of the auger. Tighten the set screw in the keyway to lock the nut. Attach the shield using two 3/8 x 3/4 inch bolts and lock nuts. If grain is leaking out around the bottom gear box, the thrust load is being carried incorrectly. Tighten the 1-1/2 inch nut until the thrust is carried at the discharge end of the auger.
9. Install the track car onto the top end of the track, and then install the 1/2” x 8” track stop bolt prior to using the auger. Failure to do so could cause the auger to collapse. Install all items this step along with the following before tightening any bolts.

On the 10 Inch 62FT AND 72FT MODELS

- a. Attach the rear lift arms to the track car using one 1/2 x 8 inch bolt, one nut, and two washers.

- b. Attach the front lift arms and short stabilizer braces to the front undercarriage mount on the lower tube using one 5/8 x 1-1/2 inch bolt, bushing, washer, and nut for each arm.
- c. Install the cross-brace weldment using six 5/8 x 1-1/2 inch bolts and nuts. Leave the top hole on each side open.
- d. Connect the rear arms to the front arms and cross-brace weldment by lifting the auger tube, moving the rear arms so that the top holes on the cross-brace and the holes in the rear arms line up. Attach the rear arms using 5/8 x 2 inch bolt, bushings, washer, and nut for each arm.
- e. Attach the axle using six 5/8 x 1-1/2 inch bolts and lock nuts.
- f. Install the front cross-brace weldment and long stabilizer braces using eight 1/2 x 1-1/2 inch bolts, and lock nuts, and two 1/2 x 2 inch bolts and locknuts.
- g. Install the two rear X-braces using five 1/2 x 1-1/2 inch bolts, and lock nuts.

On the 10 Inch 82 FT Model

- a. Attach the lift assist weldment to the track car using a 3/4" x 8-1/2" bolt and locknut; tighten snug only as this acts as a pivot.
- b. Attach the rear lift arms to the lift assist weldment using a 5/8 x 1-1/2 inch bolt, bushing, washer, and nut for each arm.
- c. Attach the front lift arms, short and long stabilizer braces, and angle-iron cross-brace as shown below
- d. Install the 3 x 3 tubing cross-brace weldment using six 5/8 x 1-1/2 inch bolts and nuts. Leave the top hole on each side open.
- e. Attach the axle using six 5/8 x 1-1/2 inch bolts and lock nuts.
- f. Install the two front and rear X-braces using five 1/2 x 1-1/2 inch bolts, and lock nuts.

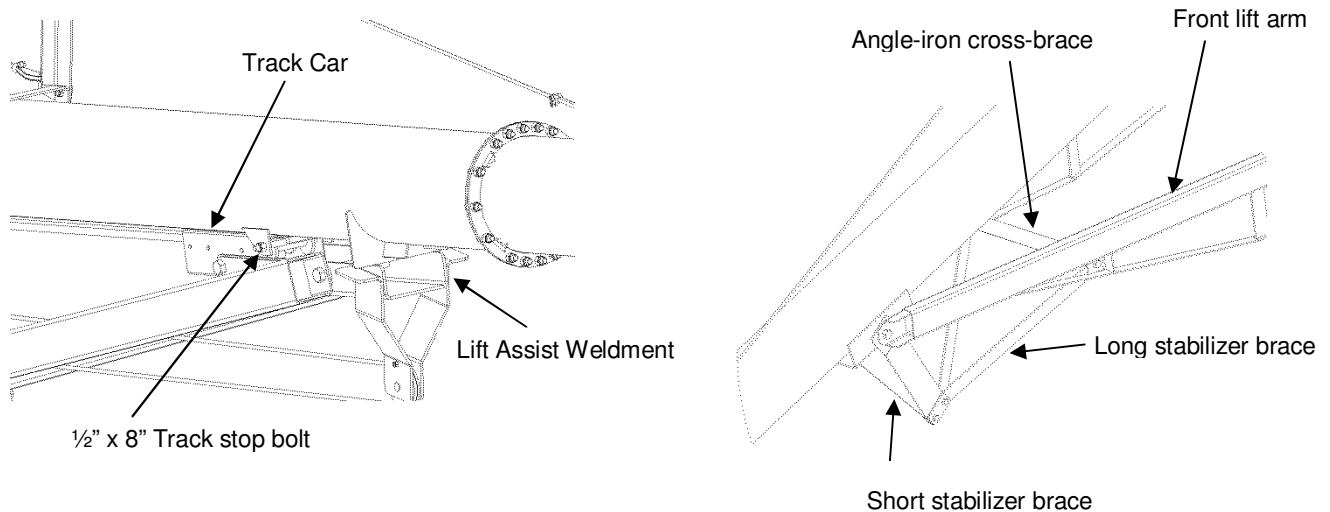

10. Mount the wheels. Align the tube so that it's centered over the undercarriage and level before tightening the bolts installed in Step 8. Tighten the bolts at each joint on the left and right side before going to the next joint to avoid the undercarriage pulling to one side by tightening all the bolts on one side first. Install the rear undercarriage arm cross-brace using eight 1/2" x 3-1/2" bolts and locknuts and two 5" x 6" rectangular plates.

11. Mount the hydraulic worm winch onto the winch mount located on the lower tube using 3/8 x 1 inch bolts and lock nuts. Loosen the set screw in the motor mount sleeve, rotate the motor about 90 degrees to install the hydraulic hoses (not furnished) and tighten the set screw. The hydraulic motor has two #10 O-rings (7/8 inch – 14 O-ring) female ports.
12. Attach the lift cable to the winch by feeding the cable into the top of the drum nearest the auger tube, making sure to have the cable extend a minimum of 2 inches past the cable keeper. The nuts for the cable keeper should be on the outside of the drum. Maintain at least 5 wraps on the drum. NOTE: Cable winch must be aligned with cable line so that the cable doesn't stack on one side of drum.

10 Inch 62 FT and 72 FT cable routing

Thread the cable under the center track stop, around, the sheave in the track car, back past the center track stop, and fasten the cable to the tube by the tube splice with two cable clamps and thimble.

10 Inch 82 FT cable routing

Thread the cable around the sheave on the lift assist weldment, from the bottom side and back on the top past the center track stop, and fasten the cable to the anchor on the lower side of the tube by the tube splice with two cable clamps and a thimble.

13. Attach the stop flags to the stop flag arms using the #10 x 3/4 inch screw and lock nuts. The lettering must face the auger tube when the arms are parallel to the tube. These flags will swing out when the track car approaches the end of the track.

NOTE: The operator must stop raising the auger when these swing out (See DANGER statement near SAFE OPERATING INSTRUCTIONS and recommendations).
14. Remove the four bolts from the front of the gearbox. Be careful not to break the seal on the front of the gearbox. Install the poly implement end PTO shield and re-install the gearbox bolts. Attach the implement input drive (IID) to the lower gear box using a 1/4 inch key and 1/4 x 2-1/4 inch spiral pin. Tighten the set screw in the IID. Mount the IID support bracket to the drive section using 2-3/8 inch bolts and lock nuts. Use the rubber strap to support the IID for transport.
15. Line up the hopper CV joint with the hopper discharge flighting and attach with 3/8 x 2 inch roll pin. Connect the hopper tube to the hopper body with 1/2 x 1-1/2 inch bolts, 1/2 inch lock nuts, and 1/2 inch flat washers. Mount hopper wheels with 3/4 x 8-3/4 inch pins and bushings.
16. Install the hopper telescoping power shaft onto the gearbox in the hopper head using 3/8 x 3 inch bolt and self-locking nut. Be sure to mount the hopper power shaft with the outer half to the upper gearbox. Place the swing drive hopper on the pivot ring centered on the drive section pivot place. Secure the hopper to the drive section using four bushings, washers, and lock nuts. The hopper can be mounted on either side of the auger. Install the hopper telescoping power shaft onto the lower gearbox in the drive section using 5/16 x 3 inch Grade 2 bolts and self-locking nut. Close all access doors and keep in place during operation.
17. Attach the swing over arm to the mount on the lower tube using the 5/8 x 4-1/2 inch pin and securing with the 1/8 inch hairpin. Mount the hopper winch to the winch mount using the 3/8 inch x 1 inch bolt and lock-nut. This winch can be mounted on either side of the auger. Thread the 3/16 inch x 35 ft hopper cable through the swing over arm and attach to the winch. The cable hook is attached to the hook located on the outside of the hopper for transporting.
18. Hitch the auger to the tractor and adjust the hitch so that the IID does not bottom out. Check for clearance as the auger is raised.
19. Refer to the Safe Operating Instructions on page 7.
20. There are several decals on the portable grain auger and its attachments with safety instructions, read and understand these safety alerts before operating. Also read and understand the Owner's Manual before operating.
21. Do not operate the auger empty during the break-in period. For the best results, do not full feed the intake for the first 500 bushels. After break-in, never run auger at slow idle when full feeding the auger.

12 INCH (72, 82, AND 92FT) AUGER

One must use extreme caution when assembling this auger. Two (2) lifting devices (i.e. Loader tractor, forklift, etc) are required as well as various wrenches and tools. Assemble the auger on a flat surface. Right, left, front, and back refer to looking at the auger from the intake end.

1. Set tubes approximately two (2) feet apart. Note the location and sequence of the tubes (i.e. 30 and 40 ft) and bolt the flighting together, as shown below, with 1/2 x 3-1/2 inch fine thread bolt and lock nut and 3/8 x 7/8 button head screw and lock nut. Slide the tubes together and attach with 1/2 x 1-1/2 inch bolts and 1/2 inch lock nuts.

NOTE: Do not fully tighten bolts in flange ring connection the first time. Work around the flange at least twice to gradually pull the connection together. Fully tightening the bolts on one side will pull the auger tubes out of alignment.

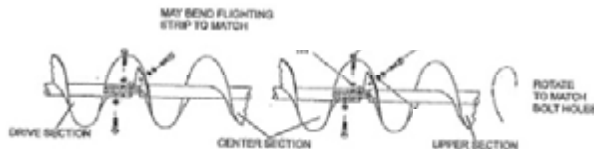

2. Lay drive section assembly flat with flange joint spaced two (2) feet away from the center auger tube. Fasten the flighting assemblies together, as shown above, with 1/2 x 3-1/2 inch fine thread bolt, lock nut, 3/8 x 7/8 button head screw and lock nut. Fasten flighting assemblies so that the drive section flight overlaps the lowest flight assembly. Make sure tubes are straight. Slide drive section and tube together and connect at flange ring with 1/2 x 1-1/2 inch bolts and 1/2 inch lock nuts.
3. Attach drop spout by sliding the flight shaft through the 1-1/2 inch bearing on the head. Connect drop spout to tube with 1/2 x 1-1/2 inch bolts and 1/2 inch lock nuts. Align the female spline in the drive section flight with the male spline on the gearbox. Push flight toward the drive section until the splines bottom out on each other. Thread the 1-1/2 inch nut onto the flighting until finger tight. Tighten the nut two (2) full turns.
4. Assembly truss risers with 3/8 x 1 inch bolts and 3/8 inch lock nut. Ensure that the correct holes are being used for the correct tube size. Attach truss risers to tubes with 5/8 x 1-1/2 inch bolts and 5/8 inch lock nuts. Note proper truss mount location for each auger length shown on the previous page. String truss cables and attach to tubes with 5/8 inch eyebolts and anchor bars. Preload the tubes by raising the discharge end four (4) inches. Tighten the nuts on the eyebolts until the discharge end raises slightly.
5. Lay out axle (on 82 and 92 ft) and attach left and right lower arms to axle with 1/2 x 1-1/2 inch bolts and 1/2 inch lock nuts. Leave attaching hardware loose. NOTE: There are six (6) holes in the mount brackets. The 82 ft augers use the inside four (4) holes while the 72 and 92 ft augers use the outside four (4) holes. Attach cross braces to front arms (loose) with 5/8 x 2-1/2 inch bolts and lock nuts. Attach X-braces to front arms with 1/2 x 1-1/2 inch bolts and 1/2 inch lock nuts. Working around the pattern at least twice, tighten the nuts on the bolts for front arms and cross braces in a cross pattern. Do not tighten the bolts fully the first time around.
6. Attach transport rest halves to the axle with 1/2 x 1-1/2 inch bolts and 1/2 lock nuts.
7. Attach top arm to lower arms with 1-1/4 x 3-3/4 inch pin, bushing, and 1/4 x 2 inch cotter pins.
8. Note location of undercarriage to tube connections shown on the next page. Attach top arm to tube support bracket with 5/8 x 2-1/2 inch bolts, 5/8 inch bushing, and 5/8 inch lock nuts. Attach front arms to axle and to tube with 5/8 inch x 2-1/2 inch bolts, 5/8 inch bushings, washers, and 5/8 inch lock nuts. Discharge end of auger may need to be raised or lowered to align holes for assembly. Attach cross brace to front arms with 1/2 x 1-1/2 inch bolts and 1/2 inch lock nuts. Attach swing over arm to tube with 1/8 inch hairpin.



CAUTION: AFTER THE TOP TUBE IS FASTENED TO THE CENTER TUBE, THE AUGER MAY OVERBALLANCE WITH THE DISCHARGE END FALLING TO THE GROUND UNLESS RESTAINED BY A LIFTING DEVICE. BEFORE REMOVING LIFTING DEVICES, ANCHOR THE INTAKE END.

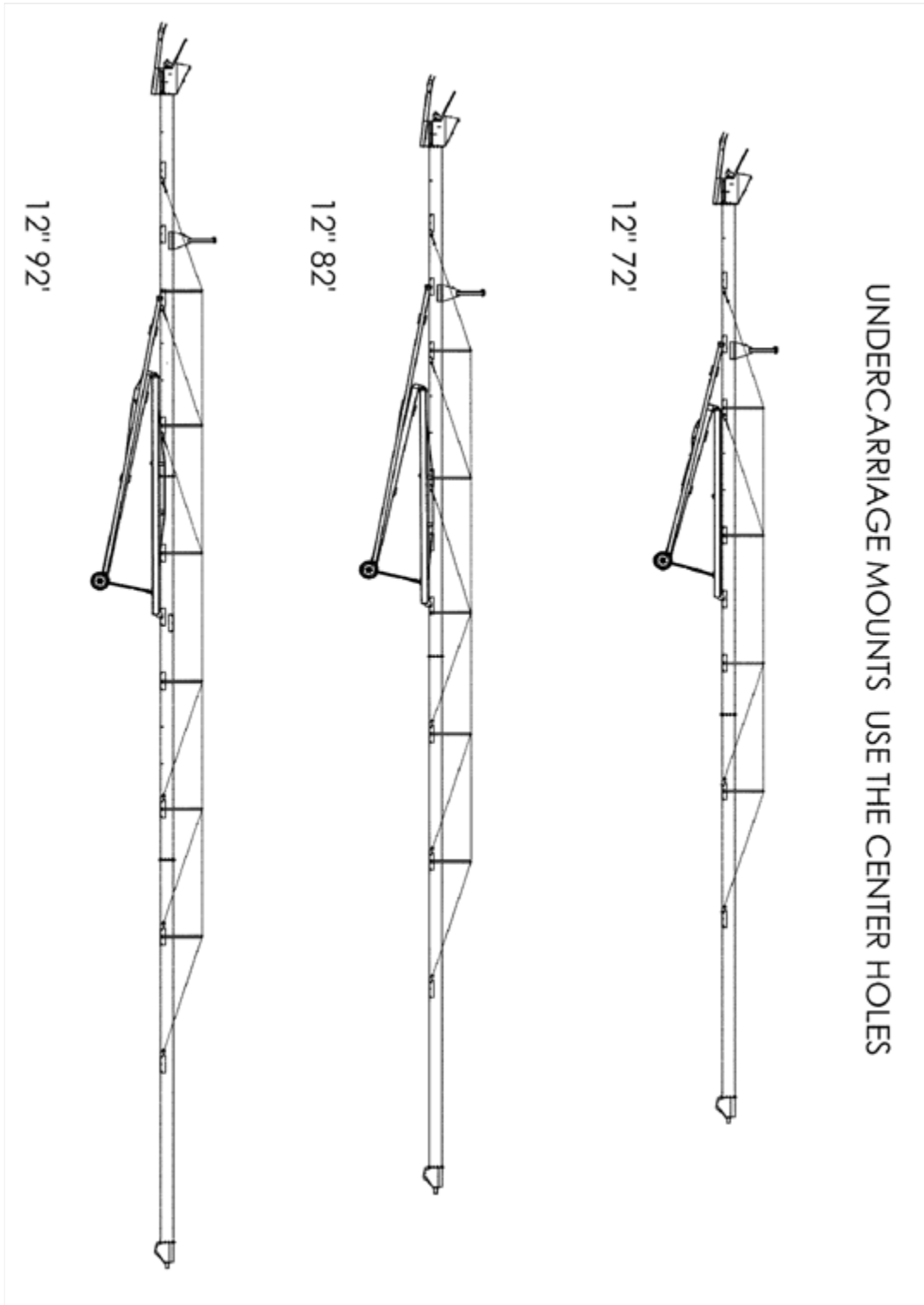

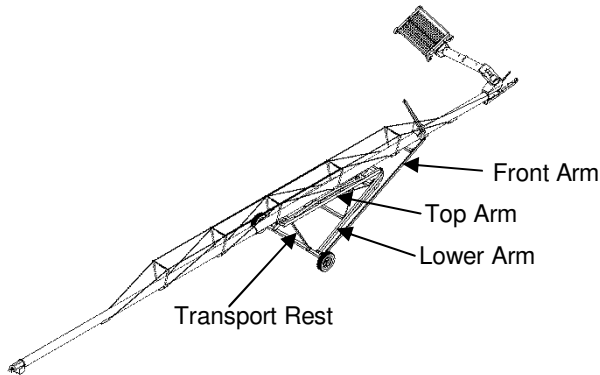

9. Mount the wheels on the hubs using the wheel bolts in the hubs. Valve stems should point away from the axle. There are 12 holes on each rim. Be sure to use the set of holes with the proper taper (i.e. taper pointing in).
10. Attach base end of lift cylinder to top arm with 1-1/4" x 6-1/2" pin for 72FT models, or a 1-1/2" x 7-3/4" for 82FT and 92FT models and 1/4" x 2" cotter pins. Route hoses from cylinder along the top undercarriage arm to the top undercarriage pivot point and back down along the auger tube, to the hitch. Attach hitch on drive section to tractor. Check tractor hydraulic reservoir to ensure proper oil level. Run hoses to tractor. Cycle cylinder full stroke at least four (4) times to ensure that the cylinder is full of oil and that air is purged from the system. Recheck tractor hydraulic reservoir for proper oil level. Attach rod end of cylinder to front arm with 1-1/4" x 4-1/2" pin on 72FT models, or 1-1/2" x 4-3/4" pin on 82FT and 92FT models and 1/4" x 2" cotter pins. Ensure that no one is near the auger, raise the auger all the way up, and then lower to transport position. Check for hose binding or stretching. Repeat the lift and lower operation.
11. Recheck the flighting thrust load. The thrust load must be carried at the discharge end of the auger. If the flight spline is bottomed out on the gearbox, turn the 1-1/2 inch nut) until they are separated by approximately 1/8 inch. Tighten the set screw in the keyway to lock the nut. Tighten the bearing lock collar. Attach the shield with 3/8 inch lock nut.
12. Remove the four (4) bolts from the front of the gearbox. NOTE: Be careful not to break the seal on the front of the gearbox. Install the poly implement end PTO shield and re-install the gearbox bolts. Mount the implement input driveline (IID) shaft to the lower gearbox with 1/4 x 2-1/4 inch spiral pin. Tighten setscrew on IID. Mount the IID hanger with 3/8 x 1 inch bolts and lock nuts. Hang IID from hanger with rubber strap.
13. Line up the hopper CV joint with the hopper discharge flighting and attach with 3/8 x 3 inch bolt and lock nut. Connect the hopper tube to the hopper body with 1/2 x 1-1/2 inch bolts, 1/2 inch lock nuts, and 1/2 inch flat washers. Attach the hopper access door. Mount hopper wheels with 3/4 x 8-3/4 inch pins and bushings.
14. Attach the hopper head assembly to tube with 1/2 x 1-1/2 inch bolts and 1/2 inch lock nuts.
15. Install bushings on the inlet pivot ring. Set hopper on drive section by putting discharge head into pivot ring and attaching with washers and 1/2 inch lock nuts. Install the hopper power shaft between the gearboxes using 3/8 x 3 inch bolt and nut on top and 5/16 x 3 inch bolt and nut on the bottom. Note: Be sure to mount the hopper power shaft with the outer half to the upper gear box. The hopper can be mounted on either side of the auger. Close access door and keep in place during operation. Hopper height may be adjusted by removing hair pin (under hopper) from hopper wheel axle. Then remove hopper wheel axle from socket and reinstall in alternate socket.
16. Mount the winch to the hopper winch mount using 3/8 x 1 inch bolts and 3/8 inch lock nuts. This winch can be mounted on either side of the auger. Thread the hopper lift cable through the swing over arm and attach to winch. The cable hook is attached to the hook located on the outside of the hopper for transporting. Raise and lower hopper to ensure proper operation. Attach the transport safety cable with 1/8 inch hairpin.
17. Refer to the Safe Operating Instructions on page 7.
18. There are several decals on the portable grain auger and its attachments with safety instructions, read and understand these safety alerts before operating. Also read and understand the Owner's Manual before operating.

Do not operate the auger empty during the break-in period. For the best results, do not full feed the intake for the first 500 bushels. After break-in, never run auger at slow idle when full feeding the auger.

12 INCH (122FT) AUGER

One must use extreme caution when assembling this auger. Three lifting devices (i.e. loader tractor, forklift, etc.) are required as well as various wrenches and tools. Assemble the auger on a flat surface. Right, left, front and back refer to looking at the auger from the intake end.

1. Attach the front undercarriage arms to the axle using twenty 1/2" x 1-1/2" bolts and locknuts. Install the 3 cross braces and pair of angle-iron X-braces to the undercarriage using twenty-nine 1/2" x 1-1/2" bolts and locknuts. **Do not fully tighten the bolts until the trussing is attached**
2. Attach the axle extensions to the axle using twelve 5/8"x 2" bolts and locknuts. NOTE: the axle extensions should not be used when transporting the auger but must be used when the auger is raised to increase the stability of the auger. If transporting before raising the auger, bolt the spindle and hub assemblies directly to the main axle, otherwise bolt the spindle and hub assemblies to the axle extensions. Mount the wheels onto the spindle and hub assemblies.

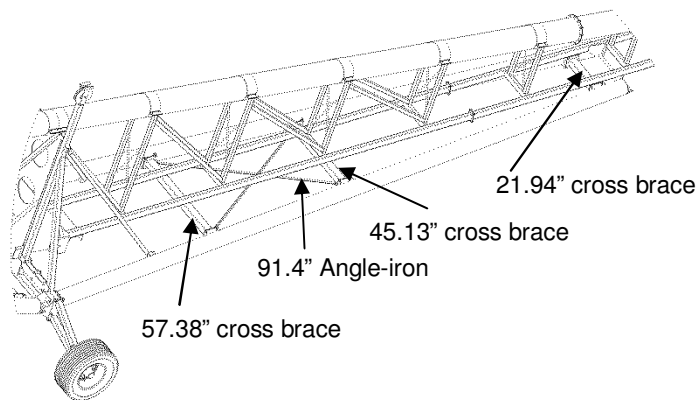

3. Assemble the two lower truss weldments using eight 1/2" x 1-1/2" bolts and locknuts. Attach the lower truss weldments to the undercarriage assembly using a 1-1/4" x 40" pin and two 1/4" x 2" cotter pins and two 1-1/4" x 10 gauge washers.
4. Position the lower tube into the lower truss section, center the 5/8" x 1-1/2" washer and locknut in the slot on the tube, but do not tighten, this will be used to adjust the trussing and keep the tubes straight.

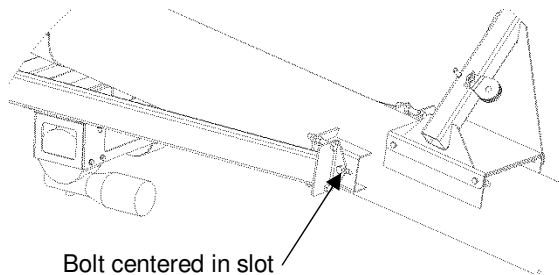

5. Attach the third trussing section to the lower 2 sections using 1/2" x 1-1/2" bolts and locknuts. Support the middle of the truss with a stand or lifting device until it is attached to the tube. With the trussing level and centered on the axle tighten the bolts on the cross-braces on the lower undercarriage arms assembled in step 1 in a crossing pattern.
6. Align one of the 2 middle tubes with the lower tubes and leave them 2' apart. Install the lower 2 pieces of flighting, and slide them together carefully so the core does not get bent. Make sure the lower flighting overlaps the upper flighting, and twist the flighting until the holes in the core line up. Bolt the flighting cores together using two 1/2" x 3-

1/2" fine threaded bolts and locknuts. Using a 3/8" x 7/8" socket head bolt and locknut, bolt the two flighting strips together.

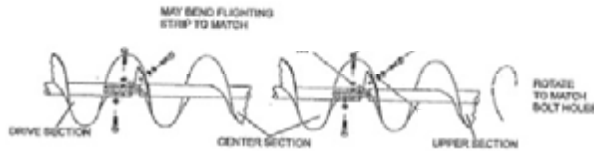

7. Slide the tubes together until the flange rings meet. Install the 1/2" x 1-1/2" bolts and locknuts in the flange ring on the auger tubes and tighten them in a crossing pattern to evenly pull the flange rings together.
8. Repeat steps six and seven assembling the third and fourth tubes and flighting to the lower 2. Support these tubes until the trussing is installed.
9. Install the upper trussing section to the lower 3, and attach it to the tube. Center the bolts holding the trussing to the tube at the top end in the slot, move the bottom joint as needed. Beginning at the bottom, use the lifting devices to straighten the tubes. Once the tubes are straight install the half clamps with 3/8" x 1-1/2" bolts, lock-washers and nuts to clamp the trussing to the tubes. Once you get to the axle bow the top end up approximately 1' and continue clamping the trussing to the tube. Use the half clamp with the truss riser welded to it on the top half clamp on the truss.
10. Install the 5/8 x 4 bolts and nuts in the truss and mounting ears on the tube. Lock one nut on each side of the mounting ear welded to the tubes. Tighten the 5/8" bolts in the slots connecting the trussing to the tubes. Ensure all the half clamps are tight and slowly let the weight of the tube down. If the tube is not bowed up slightly, loosen up the half clamps and adjustment bolts, lift up some more, and re-tighten everything until the top tube is slightly bowed up, as it will come down slightly when it is filled with grain.
11. Position the drive section in line with the lower tube and install the drive section flight and attach it to the lower flight as in step 3. Then install and tighten the bolts connecting the flange ring of the lower tube to the drive section.
12. Attach the rear undercarriage arms to the axle using two 1-1/4" x 10-1/2" pins. Attach the track car with the rollers up and the sheaves toward the intake end of the auger. Install the cross braces and angle X-braces, with thirty-seven 1/2" x 1-1/2" bolts and locknuts, but do not tighten.

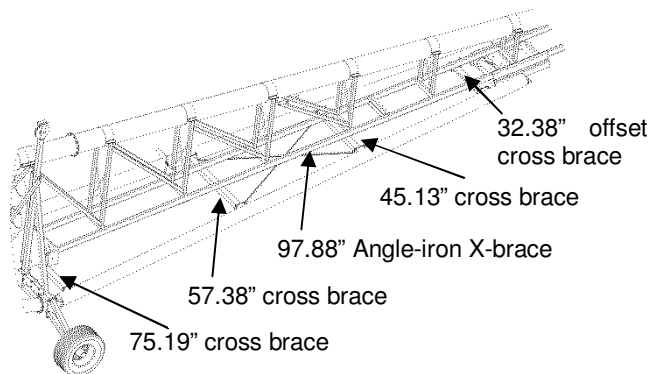

13. Slide the flighting onto the splined shaft on the drive section gearbox. Attach the discharge spout by sliding the flight shaft through the 1-1/2" bearing. Bolt the truss flange ring anchor to the discharge spout, and the spout to the tube using 1/2" x 1-1/2" bolts and locknuts. Thread the 1-1/2" nut onto the top shaft until there is approximately 1/4" of splined shaft showing on the drive section gear box. Then set the setscrew and tighten the 3/8" nut to keep the 1-1/2" nut in place, and tighten the setscrews on the bearing.
14. Attach the eyebolt truss anchors to the square tubing of the upper trussing using 5/8" x 3-1/2" bolts, washers and locknuts with the flat washers to the inside. Install the 5/8" x 6-1/2" eyebolts in the anchor bars and turn the 5/8" locknuts on a couple of turns by hand. Install two 3/8" cable clamps in the top of the truss riser with the U-bolt portion

sticking through the top plate and the 3/8" x 52' cable threaded through. Leave the clamp loose enough that the cable can slide freely for now. Loop the lower end of the cables through the eyebolts and fasten securely with 2 clamps per cable and a thimble. Leave the cable doubled back about 18" and install one clamp approximately 1" from the end and the other as close to the thimble as possible. Be certain that the U-bolt portion of the clamps is in contact with the short end of the cable. Pull the cables tight and fasten them to the flange ring anchor using the same method as fastening them to the eyebolts. Snug the cable up a little by tightening the eyebolts, and then tighten the cable clamps on the truss riser. Now tighten up the eyebolts until the auger tube has a slight bow up. **NOTE:** This cable may need to be re-tightened after operating or towing the auger.

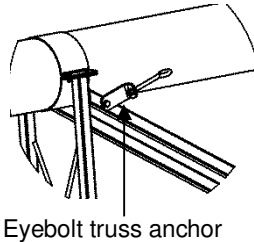

Eyebolt truss anchor

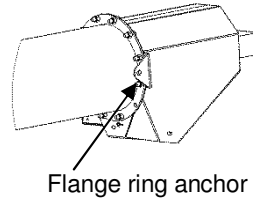

Flange ring anchor

15. Bolt the axle risers to the axle using twelve 5/8" x 4-1/2" bolts and locknuts. Install the 8' long 2x2 tubing braces connecting the axle risers to the front undercarriage arm using four 5/8 x 1-1/2" bolts and locknuts.
16. Lift the rear arms and the track car up to meet the rear trussing. Bolt the track car guides to the track car using eight 1/2 x 1-1/2" bolts and locknuts.
17. Attach the hydraulic winch assembly to the lower truss by using eight 1/2" x 1-1/2" bolts, locknuts, and flat washers. Connect 90° swivel elbows to the winch. String the hydraulic hoses through the round hose loops on the lower tube and fasten them to the swivel elbows installed in the motor on the worm winch.
18. Thread the 3/8" lift cable. Begin by fastening the cable to the winch assembly; making sure the cable comes over the top side of the winch drum. Thread the cable between the lower truss and the pivot pin. Thread the cable along the left side of the auger first, through the sheave on the tube lower truss, up over the sheave on the axle riser assembly, and then through the next sheave on the tube upper truss, up to the track car, around and through the sheaves to the right side of the auger. Come back down to the first sheave on the upper truss, then up over the sheave on the riser assembly and back down to the next sheave on the tube lower truss. Next thread the cable around the sheaves in the middle of the tube lower truss and back to the track car. Anchor the cable around the vertical pin in the car with two 3/8" cable clamps. Be sure to install the clamps with the U-bolt portion contacting the short tail of the cable for maximum holding.
19. Mount the "STOP LIFT" sign assembly on the left side of the auger to the second vertical tube on the truss above the center splice on the top auger section. Use the square plate that matches up to the stop lift flag assembly and four 3/8" x 3" bolts and locknuts. Fasten the extension spring and adjust the flag so it will catch the flat bar on the top of the track car guides. The "STOP LIFT" sign will swing out, when properly adjusted, when maximum height has been reached.

Stop lift flag assembly

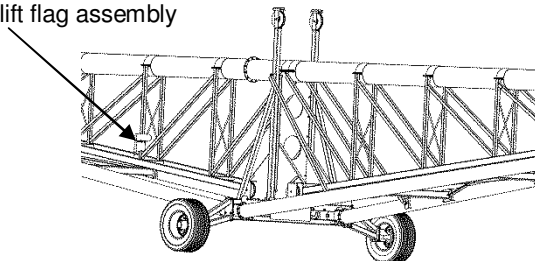

20. Remove the four (4) bolts from the front of the gearbox. NOTE: Be careful not to break the seal on the front of the gearbox. Install the poly implement end PTO shield and re-install the gearbox bolts. Mount the implement input driveline (IID) shaft to the lower gearbox with 1/4 x 2-1/4 inch spiral pin. Tighten setscrew on IID. Mount the IID hanger with 3/8 x 1 inch bolts and lock nuts. Hang IID from hanger with rubber strap.

CAUTION: BEFORE REMOVING LIFTING DEVICES, ANCHOR THE INTAKE END. AT THIS STAGE OF ASSEMBLY, THE AUGER MAY OVERBALANCE AND DISCHARGE END WILL FALL TO THE GROUND.

21. Line up the hopper CV joint with the hopper discharge flighting and attach with 3/8 x 3 inch bolt and lock nut. Connect the hopper tube to the hopper body with 1/2 x 1-1/2 inch bolts, 1/2 inch lock nuts, and 1/2 inch flat washers. Attach the hopper access door. Mount hopper wheels with 3/4 x 8-3/4 inch pins and bushings.
22. Attach the hopper head assembly to tube with 1/2 x 1-1/2 inch bolts and 1/2 inch lock nuts.
23. Install bushings on the inlet pivot ring. Set hopper on drive section by putting discharge head into pivot ring and attaching with washers and 1/2 inch lock nuts. Install the hopper power shaft between the gearboxes using 3/8 x 3 inch bolt and nut on top and 5/16 x 3 inch bolt and nut on the bottom. Note: Be sure to mount the hopper power shaft with the outer half to the upper gear box. The hopper can be mounted on either side of the auger. Close access door and keep in place during operation. Hopper height may be adjusted by removing hair pin (under hopper) from hopper wheel axle. Then remove hopper wheel axle from socket and reinstall in alternate socket. Hang IID from hanger with rubber strap.
24. Mount the winch to hopper winch mount with 1/2" x 1-1/2" bolts and 1/2" locknuts. This winch can be mounted on either side of the auger. Thread the hopper lift cable through the sheaves on the hopper lift arm and attach to winch. The cable hook is attached to the handle located on the outside of the hopper for transporting. Raise and lower hopper to ensure proper operation. Attach the transport safety cable with 1/8" hairpin and 1/2" flat washer.
25. Refer to the Safe Operating Instructions on page 7.
26. There are several decals on the portable grain auger and its attachments with safety instructions, read and understand these safety alerts before operating. Also read and understand the Owner's Manual before operating.

Do not operate the auger empty during the break-in period. For the best results, do not full feed the intake for the first 500 bushels. After break-in, never run auger at slow idle when full feeding the auger.

DRIVE

Most Art's-Way Mfg. Co. augers can be set up with a power take off drive. Some Art's-Way Mfg. Co. augers can be set up with a gasoline engine drive, electric motor drive, or hydraulic drive.

It is essential to inspect your drive before adding power and know how to shut down in an emergency. Whenever you must service or adjust your equipment, make sure you shut down and lock out your power source.

When a gasoline engine drive is used, fill with gasoline only when the motor is shut off and cool. Direct the exhaust pipe away from all flammable material. Do not run gasoline engine exhaust in a building where carbon monoxide could become a hazard.

For the electric motor driven auger, be sure all electrical cables are grounded, of the approved size, and meet all local electrical codes.

For most models you may purchase an additional auger drive to convert PTO drive to electric drive and vice-versa. Gas engine drive models cannot be converted.

PTO DRIVE ASSEMBLY

1. Attach the PTO Driveline to the gear box with a 1/4" key and 5/16" x 2" spiral pin. To reverse the side of the PTO, tip the gearbox over, remove the vent plug from the top and swap it with the drain plug on the bottom so the vent is on top after the gearbox is tipped over.
2. Mount the gearbox shield using two 1/2" x 3/4" bolts and lockwashers in the two holes closest to the intake. Install the gearbox coupler shields using two 1/2" x 3/4" bolts and lockwashers through the 2 remaining holes in the gearbox shield.
3. Install the lower fixed PTO shield using four 3/8" x 3/4" bolts and locknuts to attach it to the gearbox shield. Attach the upper PTO shield to the gearbox shield using two 3/8" x 3/4" bolts and locknuts, leave the lock nuts loose enough that the shield will fall down to cover the PTO knuckle on its own.
4. Mount PTO hanger on the auger tube using a 3/8" x 1" bolt and locknut to fasten it to the mount.

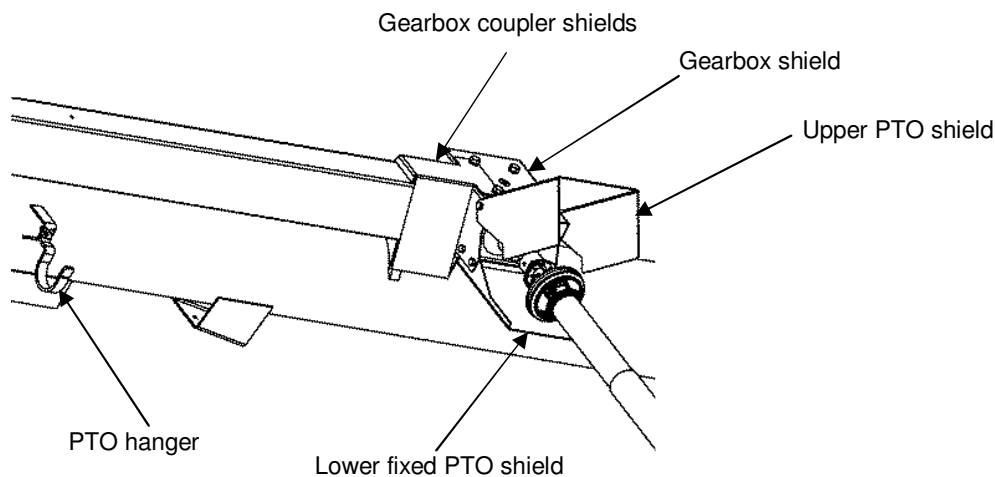

ELECTRIC DRIVE ASSEMBLY

1. Mount the gearbox shield using two 1/2" x 3/4" bolts and lockwashers in the two holes closest to the intake. Install the gearbox coupler shields and electric motor mount weldment using two 1/2" x 1" bolts and lockwashers through the 2 remaining holes in the gearbox shield.
2. Install the half clamps with the mounting ears on the top clamp, using six 3/8" x 1-1/2" bolts and locknuts. Align the holes with the holes in the electric motor mount weldment, and install two 1/2" x 1-1/2" bolts and locknuts.
3. Attach the shield plate to the two mounting points on the electric motor mount weldment using two 3/8" x 1" bolts, washers and locknuts. Install the aluminum pulley on the gearbox with a 1/4" key and setscrew.
4. Install the electric motor and pulley (4-1/2" pulley recommended, not supplied). Install the belts and tension them appropriately with two 1/2" x 8-1/2" bolts and lock them with two nuts on each bolt (one on each side of the ear attached to the sliding motor mount). Adjust the shield plate to avoid contacting the electric motor shaft, and install the shield brace angle iron with two 3/8" x 1" bolts and locknuts. Install electric shield weldment with four 1/4" x 4" bolts and locknuts.

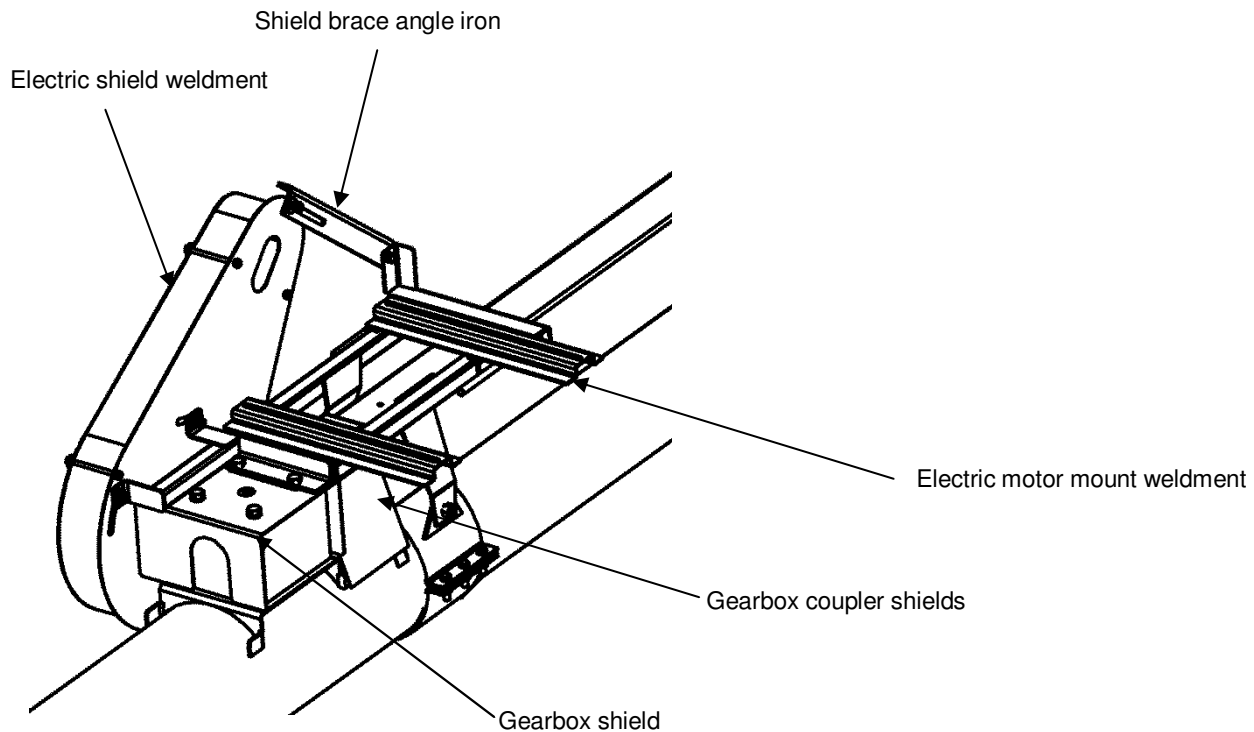

GAS DRIVE ASSEMBLY

1. Remove the gearbox from the mount welded to the tube. Remove the bottom 3 driveline shields and cut the driveline off 8" below the 3rd driveline mount from the bottom, remove the bearing and flanges from the lower 2 mounts. Attach the 1.5:1 gear ratio gearbox to the clamp-on gearbox mount re-using the bolts and lockwashers that attached the gearbox to the mount welded to the tube. Clamp on the gearbox using the lower half clamp and eight 3/8" x 1-1/2" bolts lockwashers and nuts. Slide the chain coupler over the driveline, drill a 5/16" hole in line with the coupler through the driveline and install the 5/16" bolt and nut. Attach the gas drive weldment to lower half clamp using two 1/2" x 1-1/2" bolts and locknuts. Snug the bolts up, but leave them loose enough to allow the mount to pivot.
2. Attach the two 33" angle irons to the gas mount weldment and to the pivot weldment. Remove the 1/2" nut and lockwasher from the cross braces on the lower undercarriage arm, attach the pivot weldment and re-tighten. Install the aluminum pulley on the gearbox with a 1/4" key and setscrew.
3. Mount the gearbox shield using two 1/2" x 1" bolts and lockwashers in the two holes closest to the intake. Install the gearbox coupler shields using two 1/2" x 1" bolts and lockwashers through the 2 remaining holes in the gearbox shield.
6. Install the gas motor and pulley (4" pulley recommended, not supplied). Install the belts and tension them appropriately with two 1/2" x 8-1/2" bolts and lock them with two nuts on each bolt (one on each side of the ear attached to the sliding motor mount). Be sure the engagement lever is back so the belts are tight. This lever will be moved forward to disengage the auger when starting the motor. Adjust the lower shield to avoid contacting the gas engine or belts.

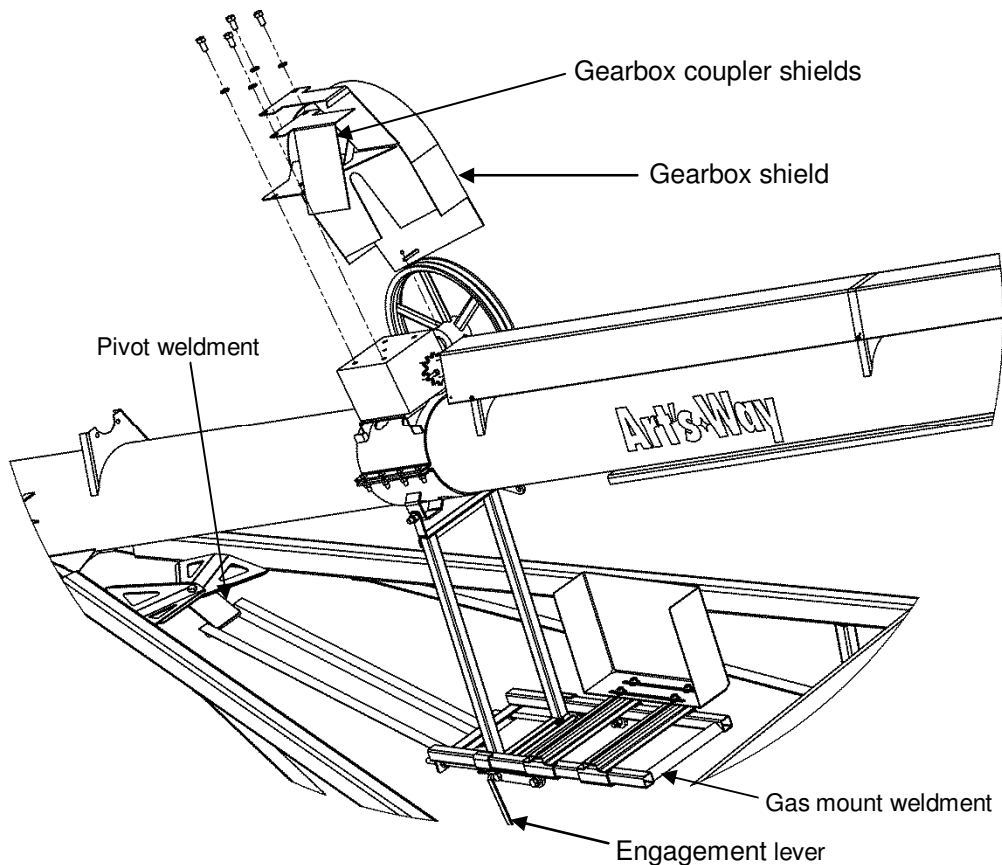

HYDRAULIC DRIVE ASSEMBLY

1. Remove the roller chain from the chain coupler and then remove the gearbox.
2. Mount the hydraulic motor to the motor mount using four 3/8" x 1" bolts and lockwashers.
3. Slide the splined sprocket on the hydraulic motor, and re-install the roller chain on the chain coupler.
4. Bolt the motor and mount assembly to the mount welded to the auger tube using four 1/2" x 1" bolts and locknuts.
5. Install the chain coupler shields on the hydraulic motor mount weldment using two 1/2" x 1" bolts and locknuts through the 2 holes in the top of the hydraulic motor mount.

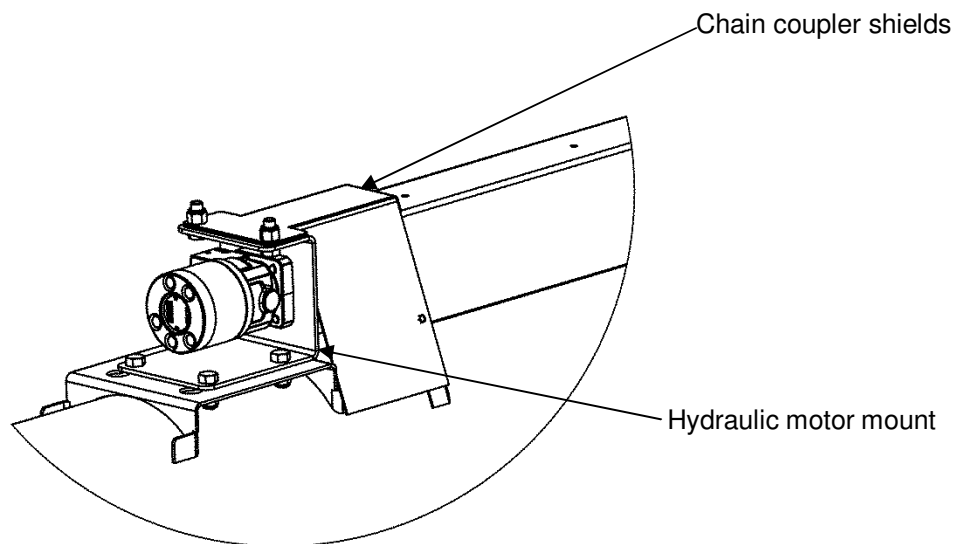

10 INCH BIN HOPPER ASSEMBLY

1. Remove the intake cage and install the hopper drive flight on the shaft of the lower flighting. Make sure the hopper drive flighting matches up with the main flighting, and clamp the two strips together. If you are not going to use the auger without the bin hopper you can weld the flighting to the existing flighting, otherwise drill a 3/8" hole through the 1" shaft of the main auger and install a 3/8" bolt and locknut.
2. Install the transition tube and half clamp using ten 3/8" x 1-1/2" bolts, nuts and lockwashers. Be sure the tabs on the half-clamp are on the intake end and are pointing straight up.

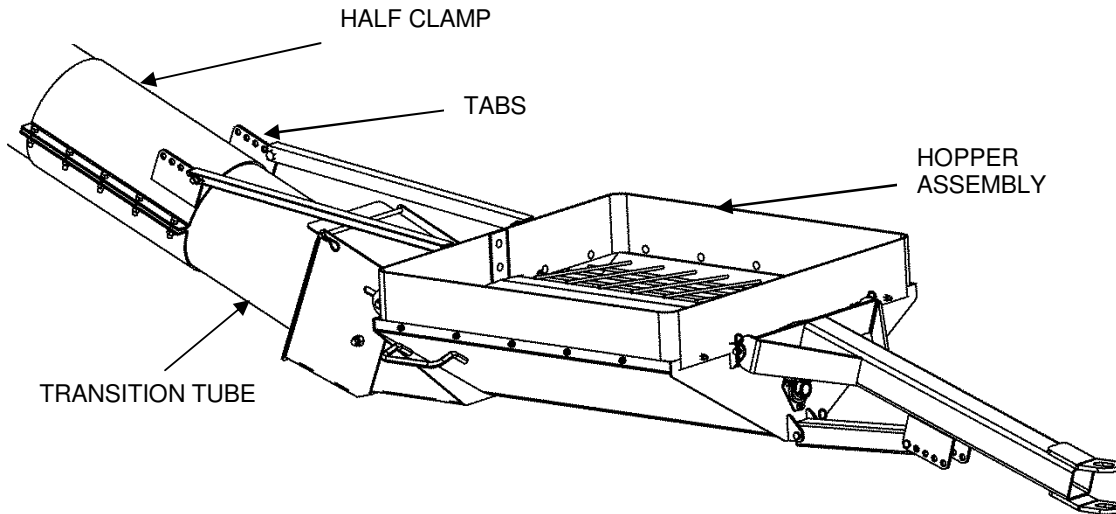

3. Slide the square end of the CV joint onto the square shaft of the transition flighting. Line up hopper assembly and slide it into place with the round end of the CV joint slipping over the shaft on the hopper assembly and the transition box on the hopper assembly fitting inside the box on the transition tube. Line up the hole in the CV joint with the hole in the auger shaft and install a 3/8" x 2" roll pin.
4. Bolt the hopper to the transition tube with four 1/2" x 1-1/4" carriage bolts and locknuts. Install large flat washers on the outside of the top slotted holes.
5. Adjust the hopper to the desired angle and install the angle irons to hold the angle constant. Install the hitch and adjust the angle to obtain the desired ground clearance.
6. Install the half clamps for using pivoting dolly jack using six 3/8" x 1-1/2" bolts, nuts and lockwashers. Align the jack as close to vertical as possible to allow the pivot to work properly. The half clamps may need to be slid lower to increase the height the jack lifts the auger.

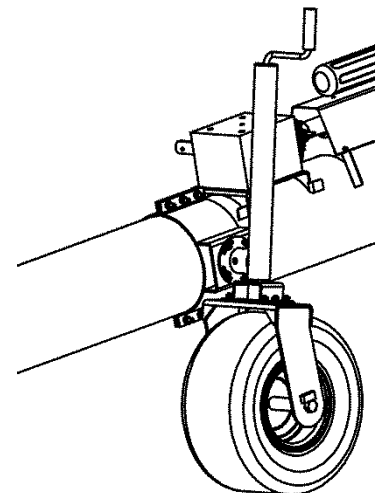

12 INCH BIN HOPPER ASSEMBLY

1. Remove the intake cage and install the hopper drive flight on the shaft of the lower flighting. Make sure the hopper drive flighting matches up with the main flighting, and clamp the two strips together. If you are not going to use the auger without the bin hopper you can weld the flighting to the existing flighting, otherwise drill a 3/8" hole through the 1" shaft of the main auger and install a 3/8" bolt and locknut.
2. Install the transition tube and half clamp using ten 3/8" x 1-1/2" bolts, nuts and lockwashers. Be sure the tabs on the half-clamp are on the intake end and are pointing up.

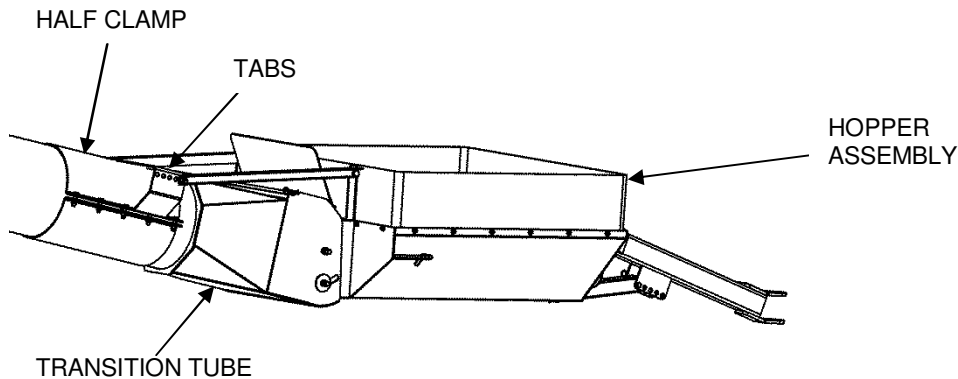

3. Slide the square end of the CV joint onto the square shaft of the transition flighting. Line up hopper assembly and slide it into place with the round end of the CV joint slipping over the shaft on the hopper assembly and the transition box on the hopper assembly fitting inside the box on the transition tube. Line up the hole in the CV joint with the hole in the hopper drive shaft and install a 3/8" x 2" roll pin.
4. Bolt the hopper to the transition tube with four 1/2" x 1-1/4" carriage bolts and locknuts. Install large flat washers on the outside of the lower slotted holes.
5. Adjust the hopper to the desired angle and install the angle irons to hold the angle constant. Install the hitch and adjust the angle to obtain the desired ground clearance.
6. Install the half clamps for using pivoting dolly jack using six 3/8" x 1-1/2" bolts, nuts and lockwashers. Align the jack as close to vertical as possible to allow the pivot to work properly. The half clamps may need to be slid lower to increase the height the jack lifts the auger.

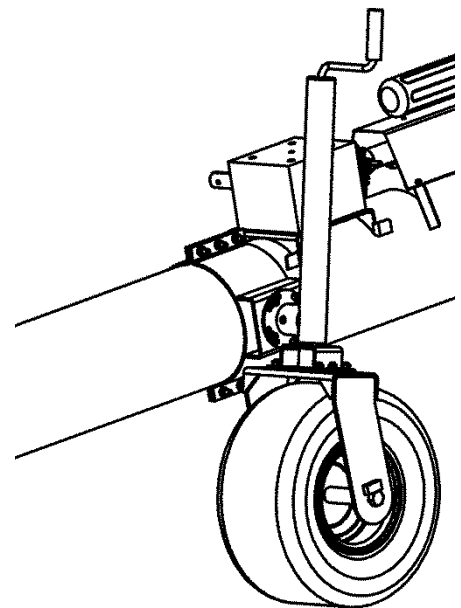

SHEAR BOLT

WHEN THE SPECIFIED SIZE AND GRADE OF SHEAR BOLT SHEARS, IT IS THE OPERATOR'S WARNING THAT AN EXTREME CONDITION EXISTS AND THAT A REDUCTION OF FLOW INTO THE HOPPER IS NECESSARY.



CAUTION: USING OTHER THEN A SPECIFIED GRADE SHEAR BOLT MAY RESULT IN DAMAGE TO THE DRIVE COMPONENTS.

Do not replace with a higher grade of shear bolt.

Using other than recommended grade shear bolt may result in damage to drive components.

When the specified size and grade of shear bolt shears, it is the operator's warning that an extreme condition exists and that a reduction of flow into the hopper is necessary.

Do not replace with a higher grade of shear bolt.

Using other than recommended grade shear bolt may result in damage to drive components

8 inch (34 ft) models	5/16 inch x 2-1/2 inch Grade 2 shear bolt located at output of gear box.
8 inch (41 ft thru 72 ft) models	5/16 inch x 2-1/2 inch Grade 2 shear bolt located at output of gear box.
10 inch (34 ft thru 44 ft) models	5/16 inch x 2-1/12 inch Grade 2 shear bolt located of gear box.
10 inch (55 ft thru 60 ft) models	5/16 inch x 1-1/4 shear Grade 2 shear bolt located at shear clutch on implement input drivelines.
10 inch (66 ft and 76 ft) models	3/8 inch x 1-1/4 inch Grade 2 shear blot located at shear clutch on Implement Input Driveline (IID).
12 inch (34 ft) models	5/16 inch x 2-1/2 inch Grade 2 shear bolt located output of gear box.
12 inch (40 ft and 46 ft) models	3/8 inch x 1-1/4 inch Grade 5 shear bolt located at shear clutch on Implement Input Driveline (IID)
14 inch (40 ft) models	3/8 inch x 1-1/4 inch Grade 5 shear bolt located at shear clutch on Implement Input Driveline (IID)
12 inch (55 ft and longer) models with 540 RPM Input	3/8 inch x 1-1/4 inch Grade 5 shear bolt located at shear clutch on Implement Input Driveline (IID)
12 inch and 14 inch (55 ft and longer) models with 1000 RPM	5/16 inch x 1-1/4 inch Grade 5 shear bolt located at shear clutch on Implement Input Driveline (IID).

INTAKE SECTIONS

THE INTAKE IS GUARDED TO PROVIDE A DETERRENT FROM ACCIDENTAL CONTACT WITH THE ROTATING FLIGHTING. DO NOT STEP OR STAND ON THE INTAKE CAGE OR HOPPER. DO NOT OPERATE THE AUGER IF THE INTAKE GUARD HAD BEEN REMOVED, REPAIRED, OR REPLACE A DAMAGED INTAKE GUARD BEFORE OPERATING. ONE PIN REMOVES THE LOW HITCH FOR USE IN HOPPERS AND CRAMPED AREAS.



CAUTION: DO NOT STEP OR STAND ON THE INTAKE SECTION. CONTACT WITH ROTATING FLIGHTING WILL CAUSE SERIOUS INJURY OR DEATH.

WINCH AND CABLE

Always inspect the straps, rope, cable, and hook before each use. Never use strap, rope, or cable that is worn, frayed, or kinked. Never let anyone stand near or under any equipment being winched. Do not stand near the winch strap, rope, or cable because it can whip violently if it should break.

Read and understand all instructions before using product. Never allow anyone unfamiliar with the operating instructions to use this product.

If you cannot crank the winch with one hand, you are probably overloading the winch.

High forces may be created by the use of a winch thereby creating potential safety hazards.

Never let go of the handle until you are sure the ratchet pawl is properly set and supporting the load. If not, the handle can spin dangerously backwards. A clicking ratchet pawl when lowering the load will not support the load.

Winches that are equipped with a two-way ratchet pawl system allow the conveniences of being wind the line onto either the top or bottom of the winch drum. IN NO CASE WILL THE RATCHET PAWL SYSTEM HOLD THE LOAD WHEN IT IS BEING LET OUT OR LOWERED.

This winch is not designed to be a human or equipment hoist and should never be operated when there are persons positioned on or under the load being moved.

The cable keeper or rope threading alone will not support the load. Never let the cable or rope all the way out. Always keep a minimum of five (5) complete wraps of the cable or rope around the drum hub.

On two speed winches make sure that the ratchet pawl is properly engaged to hold the load before attempting to change gears.

Failure to follow these instructions may result in serious injury and/or property damage.

Maintain at least five (5) full wraps of cable on the winch drum. Be sure cable had no kinks or sharp bends. Be sure cable clips are properly installed. Be sure that the cable on the winch is a diameter as furnished to support the load to be lifted.

Always inspect the cable before each use to make sure it is not damaged. Replace the cable if it is frayed or kinked.

Never permit anyone on or under the load that is being lifted.

Never stand alongside the winch cable or guide the cable with your hands. If the cable breaks, it can act as a whip and can inflict serious injury to anyone in the path of the cable.

FULTON K1051/KX1051 STANDARD WORK WINCH

1. Apply automotive type grease to both the pinion and drum gear teeth and to the OD of drum bearings. Keep this light film of grease on gear teeth at all times.
2. Keep ratchet pawl pivot, bushings, and pinions threads lubricated with automotive engine oil at all times.
3. Check break friction disc for wear. If less than 1/16 of an inch thick, cracked, or broken should be replaced.
4. During each usage, check for proper ratchet operation as follows: When cranking cable in, a loud clicking sound should be heard. When cranking cable out, there is not clicking and the ratchet pawl should be fully engaged into the ratchet gear teeth.

FULTON K1550/KX1550 STANDARD WORK WINCH

1. Apply automotive type grease to both the pinion and drum gear teeth and to the OD of drum bearings. Keep this light film of grease on gear teeth at all times.
2. Keep ratchet pawl pivot, bushings, and pinions threads lubricated with automotive engine oil at all times.
3. Check break friction disc for wear. If less than 1/16 of an inch thick, cracked, or broken should be replaced.
4. During each usage, check for proper ratchet operation as follows: When cranking cable in, a loud clicking sound should be heard. When cranking cable out, there is not clicking and the ratchet pawl should be fully engaged into the ratchet gear teeth.

ART'S-WAY HYDRAULIC ALLY DRIVEN WORM WINCH

A winch driven by a hydraulic motor is normally controlled by a valve in the tractor. Because of this situation, several additional warnings must be observed.

The winch must be aligned with the cable so that the cable does not stack on one side of the winch drum. Do not allow the cable to become slack on the winch drum. The cable may recoil and slip over the side of the drum. In either case, the cable will wind on the drum spindle and cause the winch or cable to fail, allowing the auger to drop, which may cause physical damage to the auger or may cause personal injury.

Always disconnect the hydraulic hoses from the tractor after the auger is raised or lowered to the desired position. Inadvertent movement of the hydraulic valve on the tractor may cause damage or personal injury.

Maximum elevation is determined by interference between track car and auger structure. The operator **MUST STOP RAISING** the auger **BEFORE** track car reaches the end of the track. Continued lift will cause failure to the winch, lift cable, or auger supports, causing auger to collapse, resulting in **SERIOUS INJURY OR DEATH**.

ON 12 and 14 inch (60 to 82 ft) augers, the operator **MUST STOP RAISING** the auger **BEFORE** extending member is fully extended. Continued lift will cause failure of the winch, lift cable, or auger supports, causing the auger to collapse, which can result in physical damage and possible **INJURY OR DEATH**.

Never check for hydraulic leaks using any part of the human body. Oil injection can occur, causing serious injury.

Continued running of the winch after the auger is lowered to transport position may allow the cable to become totally loose. As a result, the cable may snarl or loop on the outside of the winch drum or wrap improperly (backwards), causing the cable to rub or catch on an object. Either situation could cause cable failure and collapse of the auger.

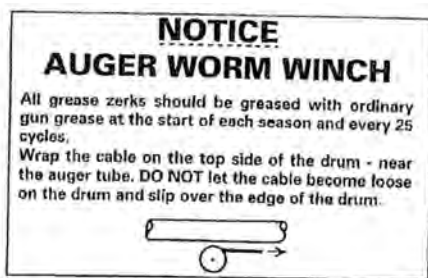

This winch is of a general purpose design and the load rating (2500 pounds) is based on an intermittent duty cycle. This winch is not designed to be a human hoist and should never be operated when there are persons positioned on or under the load being moved

Feed cable over the top of the drum nearest the auger tube, through the hole and extend the cable a minimum of two (2) inches past the cable keeper. All nuts for the cable keeper must be on the outside of the drum.

Worm Winch Break-In

If during the first few uses of the worm winch, the worm winch becomes very hot, stop and allow it to cool down before continuing. This is part of the normal break-in process.

Lubrication

Grease at the start of each season and every 25 cycles using common gun grease. Five grease zerks are located on the winch.

Never exceed the maximum rated capacity of 2500 pounds.

Maintain at least five full wraps of cable on the drum at all times.

Always inspect the cable before each use to make sure the cable is not worn, kinked, or frayed. These conditions are unsafe. Replace the cable immediately.

Be sure that the cable is strong enough to support the load to be lifted. Maximum cable size is 5/16 inch dia. 7 x 19 galvanized aircraft cable.

Never stand alongside the winch cable or guide the cable with your hands. If the cable breaks, it can act as a whip and can inflict serious injury to anyone in the path of the cable.

Never permit anyone on or under the load that is being lifted.

OPERATING INSTRUCTIONS

Art's-Way portable grain augers are designed primarily to convey grain to and from grain storage bins or buildings. This machine must have a break-in-period with different operating conditions than for normal use. The tube and flighting must get a polished surface through use. Once the new auger has polished (some need 20 bushels and some need several hundred bushels) it will run smooth at recommended speed.

1. It is essential to inspect your drive before adding power.
2. During the break-in period, run the tractor at slow idle until grain begins to flow from the discharge. For the first 500 bushels, operate at the slow speed and restrict the flow of grain at the intake. Gradually increase the speed until operating at full PTO speed. Do not run empty during break-in period.
3. After the break-in period always operate at PTO speeds between 500 and 540 RPM. Never run tractor at slow idle when full feeding the auger. Do not operate when empty as unnecessary wear occurs.
4. Do not open the grain gate on hopper bottom trailers fully as force-feeding may occur, causing an overload condition with possible damage to the unit.
5. Do not operate at slow PTO speed unless the flow of grain is also reduced. Refer to the Trouble Shooting Section on page 50.)
6. After completing the transfer of grain, run the unit until the grain has been emptied from it.

MOVING INSTRUCTIONS

CONNECT THE HYDRAULIC HOSE TO THE TRACTOR, RAISE/LOWER THE AUGER TO CLEAR ANY OBSTRUCTIONS.

1. Raise the hopper into transport position before moving the auger.
2. Remove the implement input drive (IID) from the tractor whenever moving the auger. Failure to do this every time may cause damage to the CV joint in the IID.
3. Only transport the auger in the fully down position.
4. Do not tow over 20 mph.

HITCH ADJUSTMENT

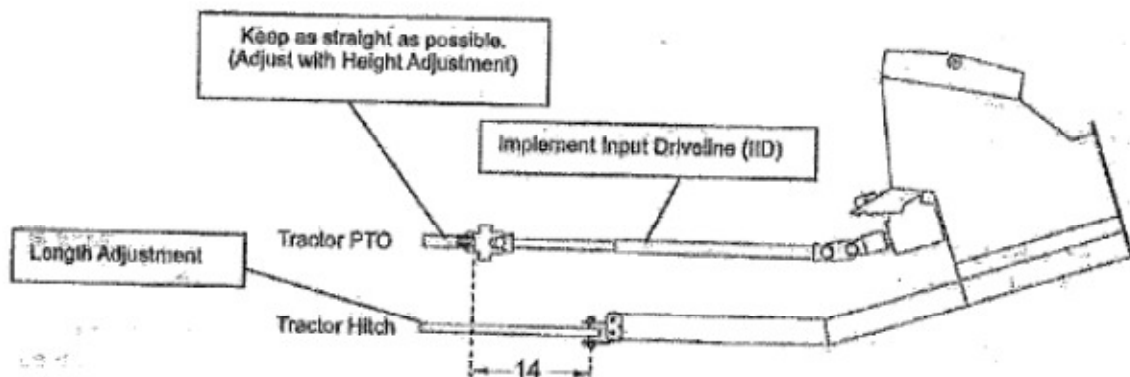

CAUTION: IT IS IMPORTANT TO ADJUST YOUR HITCH. THE ILLUSTRATION ABOVE IS YOUR GUIDE TO PROPER HITCH ADJUSTMENT. IMPROPER ADJUSTMENT CAN CAUSE DAMAGE AND/OR EXCESSIVE WEAR ON U-JOINT ASSEMBLIES.

NOTE: The shielding has been removed in the illustration for parts demonstration only. Install all shielding before operating the unit.

The tractor should be positioned to the auger so that the distance from the end of the tractor PTO shaft is 14 inches from the hitch pin. Use the tractor drawbar length adjustment. This is so the implement input driveline (IID) does not bottom out when the auger is raised to maximum position. Vertical adjustment is a trial and error process. The goal is to have an equal angle on the IID U-joints in the operating position.

The IID should be disconnected from the tractor while positioning the auger, otherwise physical damage may result in the IID or auger.

The result of improper hitch adjustment is breaking the ball inside the CV joint. Bending in excess of 50 degrees on the CV joint will also break the ball inside the CV joint. Constant angle applications require more frequent greasing. See lubrication section for greasing procedures.

CYLINDER LIFT

12 Inch (72, 82, and 92 ft) commercial swing drive auger is equipped with a hydraulic cylinder to provide lift.

Any settling of auger is due to hydraulic oil leaking past the cylinder piston. If the auger will not lower, dirt in the counterbalance valve may have blocked the piston from operating the valve. The “downside” of the counterbalance valve should be removed and cleaned.

Always disconnect the hydraulic hoses from the tractor after the auger is raised or lowered to the desired position. Inadvertent movement of the hydraulic valve on the tractor may cause damage or personal injury.

Never check for hydraulic leaks using any part of the human body. Oil injection can occur, causing serious injury.

Refer to the winch and cable section for full details on the Fulton Winch.

MAINTENANCE

Proper maintenance on the auger means a longer life for the machine and a safer and more efficient operation.



CAUTION: KEEP CHILDREN AWAY WHEN PERFORMING MAINTENANCE.

CAUTION: BEFORE PERFORMING ANY MAINTENANCE, ENSURE THAT POWER IS SHUT DOWN AND LOCKED OUT.

CAUTION: WHERE POSSIBLE, PERFORM MAINTENANCE WITH AUGER IN FULL DOWN POSITION.

CAUTION: REPLACE ALL SHIELDS.

GENERAL MAINTENANCE PROCEDURE

We recommend the following steps for the general maintenance of this auger:

1. Observe the safe guidelines and checklist in this manual on a daily basis when auger is in use.
2. Check all operating, lifting and transport components. Replace damaged or worn parts before using auger.

NOTE: To replace a damaged part, refer to assembly instructions on page 12.

Intake Hopper Angle Drive

Lubricate the angle-drive after every 8 hours of operation. Use high temperature grease.

NOTE: If the angle drive in hopper runs hot AFTER an appropriate break-in period, this may mean the angle drive is not properly aligned. To correct, first lock out power, then loosen bolts securing the angle drive and adjust or shim up until the flight can fairly easily be rotated by hand.

Hydraulic Hose

Check hose and hose coupler frequently for leaks, wear or damage. Replace if necessary. Use cardboard when searching for leaks.

Lift Cable

Check and replace if frayed or damaged. Make certain that cable clamps are secure.

Cable Sheaves

Oil sheave pins on lift cylinder twice a year.

Truss Cables

Adjust as needed to keep auger tube reasonably straight.

Wheel Hubs

Repack every two or three years with lithium based grease.

Tire Pressure

Check with a pressure gauge monthly or when pressure seems low. We recommend that pressure be maintained at 18 to 24 PSI (124 to 165 kPa).

Hopper Lift Cable

Check and replace if frayed or damaged.

Hopper Lift Cable Pulleys

Oil lightly several times a year for easier raising of hopper.

Winch

Keep a film of grease on gears. Occasionally oil the bushings, drum shaft and ratchet.

Optional Low Profile Hopper

Frequently: Loosen the two nuts securing the service door. Open door - then grease the four bushings and the two u-joints. Close door, then securely tighten the two 3/8" nuts.

Occasionally: Check and adjust the hopper drive chain and lubricate the hopper drive chain. To adjust chain, loosen the bearing bolts and adjust chain tension to about 1/4" deflection. REPLACE SHIELD.

PTO Driveline

Lubricate all FIVE grease fittings regularly with good quality LITHIUM SOAP BASE E.P. GREASE meeting the NLGI #2 specifications and containing no more than 1% molybdenum disulfide. (Example: SHELL SUPER DUTY or EQUIVALENT)

Grease fittings No. 2 and 3 can be reached through hole in implement end portion of the driveline shield.

Grease fitting No. 4 can be reached through hole in center portion of the driveline shield.

The first lube interval should be 16-24 hours of operation after initial start-up, and then follow the schedule.

LUBE RECOMMENDATIONS		
INTERVAL	LOCATION	AMOUNT
8 HRS.**	CROSS & BEARING	1 PUMP
8 HRS.	TELESCOPING MEMBERS	4-8 PUMPS
8 HRS.**	CV BALL & SOCKET	1-2 PUMPS

** Constant angle applications must have lube interval of 4 hours.



CAUTION: REPLACEMENT PARTS ARE NOT LUBRICATED

Replacement parts must be lubricated at time of assembly. Use amount listed above per location, then follow lube recommendations outlined above for lubing intervals.

Ensure that the setscrews and shear-bolt are tight.

SERVICING OF MECHANICAL DRIVE SYSTEMS

Bottom Chain Drive

Keep drive chain tension adjusted to about 1/4" deflection by loosening the four bolts on lower bearing, then retighten. Oil chain frequently enough to keep film of oil on chain (this can be done through hole in top of sprocket shield). Replace sprocket shield after maintenance.

Universal Joint

Flip up safety discharge door and lubricate grease fitting in the u-joint every 8 hours of operation. Check setscrews and retighten if necessary.

Bearing

Lubricate grease fitting on lower flight bearing. Replace sprocket shield after maintenance.

GEAR BOX

The gear box is shipped dry. Use SAE No. 90 grease. For best results, maintain the gearbox at half (1/2) full.

MODEL	Amount
8 inch (34 ft)	18 oz
8 inch (41 ft thru 72 ft)	18 oz
10 inch models	18 oz
12 inch (34 ft thru 46 ft)	18 oz
14 inch (40 ft)	18 oz
12 inch (55 ft thru 82 ft)	74 oz
14 inch (55 ft thru 82 ft)	74 oz

Head drives and chain cases are serviced with all-purpose grease at the factory. Maintain the grease to just below the lower bearings. Add 1 pound of grease at the start of each season.

Implement Input Drivelines (IID) should be lubricated periodically.

LUBRICATION

GROUND HUGGER HOPPER

The CV joint in the hopper has three (3) grease zerks. Lubricate the IID every 4 hours with NLGI #2 E.P grease containing no more than 1 % molybdenum disulfide.

The hanger bearing in the hopper must be greased every 8 hours of operation with all-purpose grease.

The chain case, located at the end of the hopper, is serviced with all-purpose grease at the factory. Maintain the grease to just below the lower bearings. Add one (1) pound of grease at the start of each season.

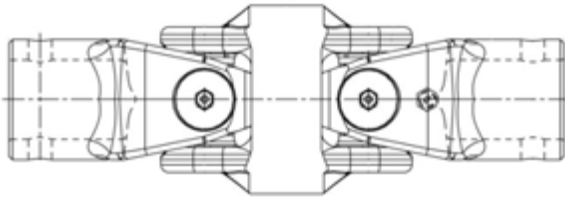

TRACTOR TO MAIN AUGER

12 inch commercial swing drive augers use an implement input driveline (IID) with four (4) grease zerks. Three (3) of the zerks are located on the CV joint on the implement end of the IID and one (1) is located on the U-joint on the tractor end. Lubricate the IID every 8 hours with NLGI #2 E.P grease containing no more than 1 % molybdenum disulfide. NLGI #2 E.P. grease containing no more than 3% molybdenum disulfide may be used on the telescoping and CV ball and socket members only.

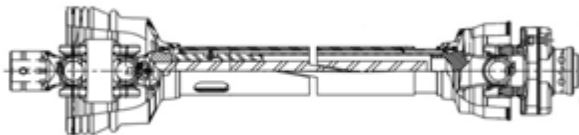

INTERNAL POWER SHAFT

12 inch commercial swing drive augers use a power shaft between the two gearboxes. The grease zerks need to be lubricated every 8 hours with NLGI #2 E.P grease containing no more than 1 % molybdenum disulfide.

GEAR BOX

The gearboxes are filled at the factory. Leakage may occur during shipment. Check lube level before using. Use SAE #90 grease. All 12 inch models take 12 oz in each gear box. For best results, maintain gear boxes at 1/2 full.

Oil Level

To check the oil level, remove the level plug located below. The oil should be level with the bottom of this opening. If more oil is needed..

Oil Change Information

The winch vent/fill and drain plugs are located as shown. Oil should be changed after the first 24 hours of operating time. Then the oil should be changed every 100 hours of operating time, or every six months, whichever comes first.

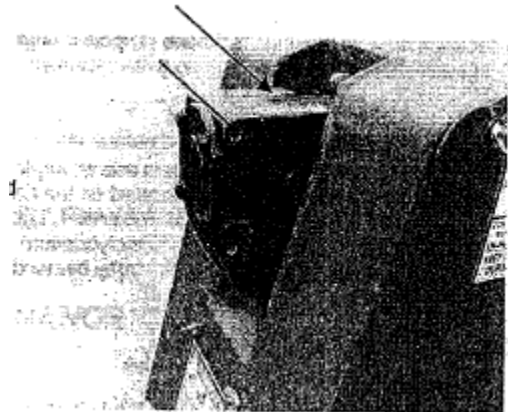

TRANSPORT



CAUTION: WHEN RAISING OR LOWERING THE AUGER, BE SURE THE WHEELS OF THE AUGER OR TOWING UNIT ARE FREE TO MOVE. BECAUSE OF THE SCISSOR ACTION OF THE UNDERCARRIAGE ASSEMBLY WILL RESULT IN DAMAGE TO THE UNIT IF THE WHEELS CAN NOT MOVE.

PRE-TRANSPORT

Before transporting auger, ensure that:

1. Make sure the auger is in full down-position with PTO driveline disconnected from tractor. The lift-assist arm must be seated against the track and the track car against the track stop with slight tension on the lift cable
2. Make sure that the hitch pin and safety chain are in place and secure. Place safety chain through clevis welded to auger hitch tube and bolt together before attaching to tractor.
3. Make sure that the intake feed hopper is raised into transport position and secured with saddle pin and hairpin.



CAUTION: DO NOT OPERATE THE AUGER WITH THE INTAKE HOPPER IN THE TRANSPORT POSITION. THIS WILL DAMAGE THE U-JOINT.

4. Make sure that the swivel jack (on side of hitch) is in transport position and locked.
5. The transport tongue must be securely fastened to the intake cage before moving the auger.
6. Make sure some tension is applied to the lift cable during transport.

TRANSPORTING

When transporting the auger, remember to:

1. Ensure that all unauthorized personnel are clear of transport zone.
2. Be alert to overhead obstructions and electrical wires and devices. The augers have minimum clearances from 12 to 14 feet (3.66 m to 4.30 m), with auger hitch at 20 inches.
3. Do not transport auger at speeds greater than 20 mph (32 km/h).
4. Observe all regulations concerning marking, towing, and maximum width.
5. Equip the auger with the necessary lights where required by law.
6. Do not transport auger on slopes greater than 20 degrees.
7. Use extreme caution in turning and cornering when towing auger.

STORAGE

GOING TO STORAGE

To protect auger in storage during the off-season, perform the following:

1. Lower the auger to full down position with slight tension on the cable.
2. Lubricate all grease fittings per the maintenance section.
3. Inspect auger for damage and note any repairs required. Order replacement parts from your dealer.
4. Check tire pressure and inflate to 24 PSI (165 kPa).
5. Clean and re-lubricate the spline on PTO driveline. Cover PTO driveline with a plastic bag to protect it from the weather and place it in the transport saddle.
6. Tow auger to storage area. Park and chock wheels.

RETURNING TO SERVICE FROM STORAGE

To prepare auger for use after storage, perform the following:

1. Check tire pressure and inflate to 24 PSI (165 kPa) if necessary.
2. Tow auger to worksite, being mindful of electrical wires overhead.
3. Remove waterproofing from spline of PTO driveline and re-lubricate.
4. Replace any damaged parts and decals.
5. Conduct general maintenance procedure before using auger.
6. Before raising auger after storage, make certain cable is in good condition, replacing it if frayed or damaged. In addition, ensure that cable is properly seated in cable sheaves on lift cylinder and that cable clamps are secure.

TROUBLE SHOOTING

The most frequent problem is created by the operator who does not read or heed this sign that is placed on the tube just below the gear box on every new auger.

If the new auger is vibrating and “jumping up and down” the operator has violated the above “break in” rules and may already have damaged the auger. Once the new auger has polished (some need 20 bushels and some need several hundred bushels) it will run smooth at recommended speeds. After break in, run the tractor PTO at 540 RPM (1000 RPM for some 12 inch models and 14 inch (55 ft and longer)) to obtain the required flighting speed for near capacity.

Plugging. Grain build-up under the spout from an over-filled bin should cause the relief discharge to open. Snow or ice mixed with grain during difficult harvest seasons can cause the relief discharge to freeze and fail to function. Check this frequently when operating under such conditions.

Plugging can occur when full feeding the intake with slow auger flighting speed. This permits the flights to overfill. Refer to Trouble Shooting No 1. Plugging can also be caused by foreign objects (such as rags, sacks, cans, etc.) which go part way up the tube and wedge between the flights. This can restrict or completely stop the flow of grain.

When the flighting will not turn :

If no foreign object is present

If the bin is not over-filled

If the grain is dry

You should remove the flighting and check it. Also check the flighting connection for damage (on 34 ft through 82 ft models) to be sure the lower half flighting laps the upper half flighting. Refer to the diagram on the assembly instructions.

A rare and unexplainable plugging can occur when temperatures, humidity, and moisture contents of the grain reach a certain level, along with ice or snow. Under these conditions, sometimes the auger will freeze. Then placing in an environment above 32° F (0° C) may loosen the auger. Most of the time the auger plugs due to these conditions: It plugs so tight you may damage the auger clearing it. Pliers, pipe wrenches, chains, and patience are necessary to clear the machine. Problems seem to be greater when operating in snow or ice. The only solution seems to be by limiting intake by covering some of the intake cage.

Plugging can occur in a situation like removing grain (wet or dry) from a full bin or a deep pit, causing force feeding, and creating an overload. This situation becomes more apt to cause problems when auger flighting speed is very low, permitting the flights to over-fill.

A shear bolt is used to prevent damage to the auger. A shear bolt, like a slip clutch, works well when a shock load is transmitted. Many times when an auger plugs, the build-up is slow and smooth and sometimes damage can be done before the bolt shears. There is also the possibility of the coupler by the gear box on the shaft so tight the bolt does not have a chance to shear. Refer to page 38 for location and grades of the shear bolts.

If you hear any unusual noises after the initial break-in period, you should remove the flighting and inspect it. It is easy to remove the flighting. Simply remove the cross pin (visible through discharge spout), remove the intake cage guard and tow hitch, and take the flight out of the intake end. Be sure to replace the intake guard before operating the auger again.

If power requirements seem excessive, check the line voltage and ampere rating of the motor or speed of the gasoline engine. Refer to assembly instructions for proper pulley size on motor, gasoline engine, and auger. A partially plugged auger will require excessive amounts of horsepower.

Grease working out of bearings on the driveline is nothing to be concerned about, and will stop when excess has worked out. Grease working out of enclosed head drive is a small amount of liquid that separates from the all-season gun grease. The grease needed for lubricating will remain in the case.





Capacity problems. Our sales literature states capacities for the various sizes of auger and notes that extreme conditions will reduce capacity. The degree of angle, moisture content, and speed of flighting are the main factors. Dirty grain or high moisture grain will not flow as well and is usually restricted some by the intake guard, thus reducing the capacity substantially.

Do not run the auger when empty, as unnecessary wear occurs.

TORQUE SPECIFICATIONS

Use these torque values when tightening hardware (excluding: locknuts, self-tapping, thread forming, and sheet metal screws) unless specified.

All torque values are in lb-ft except those marked with an asterisk (*) which are lb-in. For metric torque value Nm, multiply the lb-ft or lb-in value by 0.113.

Unified National Thread	Grade 2 		Grade 5 		Grade 8 	
	Dry	Lubed	Dry	Lubed	Dry	Lubed
8-32 8-36	19* 20*	14* 15*	30* 31*	22* 23*	41* 43*	31* 32*
10-24 10-32	27* 31*	21* 23*	43* 49*	32* 36*	60* 68*	45* 51*
1/4-20 1/4-28	66* 76*	50* 56*	9 10	75* 86*	12 14	9 10
5/16-18 5/16-24	11 12	9	17 19	13 14	25	18 20
3/8-16 3/8-24	20 23	15 17	30 35	23 25	45 50	35
7/16-14 7/16-20	32 36	24 27	50 55	35 40	70 80	55 60
1/2-13 1/2-20	50 55	35 40	75 90	55 65	110 120	80 90
9/16-12 9/16-18	70 80	55 60	110 120	80 90	150 170	110 130
5/8-11 5/8-18	100 110	75 85	150 180	110 130	220 240	170 180
3/4-10 3/4-16	175 200	130 150	280 300	200 220	380 420	280 320
7/8-9 7/8-14	170 180	125 140	430 470	320 360	600 660	460 500
1-8 1-14	250 270	190 210	640 710	480 530	900 1000	680 740
Metric Course Thread	Grade 8.8 		Grade 10.9 		Grade 12.9 	
	Dry	Lubed	Dry	Lubed	Dry	Lubed
M6-1	8	6	11	8	13.5	10
M8-1.25	19	14	27	20	32.5	24
M10-1.5	37.5	28	53	39	64	47
* M12-1.75	65	48	91.5	67.5	111.5	82
M14-2	103.5	76.5	145.5	108	176.5	131
M16-2	158.5	117.5	223.5	165.5	271	200

TIGHTEN HYDRAULIC FITTINGS



CAUTION: ESCAPING FLUID UNDER PRESSURE CAN PENETRATE THE SKIN CAUSING SERIOUS INJURY. RELIEVE PRESSURE BEFORE DISCONNECTING HYDRAULIC OR OTHER LINES. TIGHTEN ALL CONNECTIONS BEFORE APPLYING PRESSURE. KEEP HANDS AND BODY AWAY FROM PIN HOLES AND NOZZLES WHICH EJECT FLUIDS UNDER HIGH PRESSURE. USE A PIECE OF CARDBOARD OR PAPER TO SEARCH FOR LEAKS. DO NOT USE YOUR HAND.

TIGHTENING FLARE TYPE FITTINGS

Check flare and flare seat for defects that might cause leakage.

Align hose end with fitting before tightening.

Lubricate connection and hand tighten swivel nut until snug.

To prevent twisting the hose, use two wrenches. Place one wrench on the hose end body and with the second wrench, tighten the swivel nut to the torque shown in this chart.

Tube Size OD	Nut Size Across Flats	Torque Value*		Recommended Turns To Tighten (After Finger Tightening)	
		(Nm)	(lb-ft)	(Flats)	(Turns)
(in.)	(in.)				
3/16	7/16	8	6	1	1/6
1/4	9/16	12	9	1	1/6
5/16	5/8	16	12	1	1/6
3/8	11/16	24	18	1	1/6
1/2	7/8	46	34	1	1/6
5/8	1	62	46	1	1/6
3/4	1-1/4	102	75	3/4	1/8
7/8	1-3/8	122	90	3/4	1/8

NOTE: Torque values shown are based on lubricated connections as in reassembly.

TIGHTENING O-RING FITTINGS

Inspect O-ring and seat for dirt or obvious defects.

On angle fittings, back the locknut off until washer bottoms out at top of groove.

Hand tighten fitting until backup washer or washer face (if straight fitting) bottoms on face and O-ring is seated.

Position angle fittings by unscrewing no more than one turn.

Tighten straight fittings to torque shown.

Tube Size OD	Nut Size Across Flats	Torque Value*		Recommended Turns To Tighten (After Finger Tightening)	
		(Nm)	(lb-ft)	(Flats)	(Turns)
(in.)	(in.)				
3/8	1/2	8	6	2	1/3
7/16	9/16	12	9	2	1/3
1/2	5/8	16	12	2	1/3
9/16	11/16	24	18	2	1/3
3/4	7/8	46	34	2	1/3
7/8	1	62	46	1-1/2	1/4
1-1/16	1-1/4	102	75	1	1/6
1-3/16	1-3/8	122	90	1	1/6
1-5/16	1-1/2	142	105	3/4	1/8
1-5/8	1-7/8	190	140	3/4	1/8
1-7/8	2-1/8	217	160	1/2	1/12

NOTE: Torque values shown are based on lubricated connections as in reassembly.

SPECIFICATIONS

GENERAL

Model

8 inch (34, 41, 46, 55, 60, 66, and 72 ft length)

10 inch (34, 44, 55, 60, 66, and 76 ft length)

12 inch (34, 40, 46, 55, 60, 66, 72, 76, and 82 ft length)

14 inch (40, 55, 66, 76, and 82 ft length)

Height

8 inch – 21 ft to 50 ft

10 inch – 23 ft 6 inch to 49 ft 6 inch

12 inch – 21 ft to 55 ft 10 inch

14 inch – 26 ft 8 inch to 55 ft 10 inch

Power Source

PTO Drive

Gas Drive – 8 inch (34 ft) and 10 inch (34 ft)

Electric -

Hydraulic – 8 inch (34 ft) and 10 inch (34 ft)

Capacity

8 inch –



10 inch –

12 inch – Up to 6,000 bph (dry corn)

14 inch – Up to 9,000 bph (dry corn)

SAE Bolt Identification

Identification of SAE Bolt Grades; Head Markings

Grades 0, 1, and 2 - No markings	
Grades 5: 3 radial dashes 120° apart	
Grades 8: 6 radial dashes 60° apart	

NOTES

NOTES



ART'S-WAY MANUFACTURING CO., INC. TECHNICAL MANUALS

Manuals are available from your local dealer or Art's-Way Manufacturing Co., Inc. for the operation, service, and repair of your machine. For prompt convenient service, contact your local dealer for assistance in obtaining the manuals for your machine.

Your local dealer can expedite your order for operator manuals, illustrated parts catalogs, service manuals, and maintenance records.

Always give the Machine Name, Model, and Serial Number so your local dealer can provide the correct manuals for your machine.

Art's-Way Manufacturing Co., Inc. reserves the right to make improvements in design or changes in specifications at any time without incurring any obligation to install them on units previously sold.

Except as expressly authorized, no part of this manual may be reproduced, copied, transmitted, disseminated, downloaded or stored in any storage medium, for any purpose without the express prior written consent of Art's-Way Manufacturing Co., Inc.

ART'S-WAY MANUFACTURING CO., INC.

HWY 9 WEST - PO Box 288

Armstrong, IA. 50514 U.S.A

© Copyright 2009

ART'S-WAY MANUFACTURING CO., INC.

All Rights Reserved

Produced And Published In The U.S.A. By



CPS DYNAMICS, LLC

PO Box 9007

Wichita, KS 67205

www.cpsdynamics.com



Art's-Way Manufacturing Co., Inc.

Hwy 9 West – PO Box 288

Armstrong, IA. 50514 U.S.A