



Art's-Way Manufacturing Co., Inc.

Model 9016-BT
Beet Tandem High Dump

Operator's Manual & Illustrated Parts List
619650

Issued October 2016



This symbol means ATTENTION! BECOME ALERT! YOUR SAFETY IS INVOLVED. The message that follows the symbol contains important information about your safety. Carefully read the message. Make sure you fully understand the causes of possible injury or death.

IF THIS MACHINE IS USED BY AN EMPLOYEE, IS LOANED, OR IS RENTED, MAKE SURE THAT THE OPERATOR UNDERSTANDS THE TWO INSTRUCTIONS BELOW.

BEFORE THE OPERATOR STARTS THE ENGINE:

GIVE INSTRUCTIONS TO THE OPERATOR ON SAFE AND CORRECT USE OF THE MACHINE.

MAKE SURE THE OPERATOR READS AND UNDERSTANDS THE OPERATOR'S MANUAL FOR THIS MACHINE.

 **WARNING**

IMPROPER OPERATION OF THIS MACHINE CAN CAUSE INJURY OR DEATH.

BEFORE STARTING THE ENGINE, DO THE FOLLOWING:

1. READ THE OPERATOR'S MANUAL.
2. READ ALL SAFETY DECALS ON THE MACHINE.
3. CLEAR THE AREA OF OTHER PERSONS.
4. LEARN AND PRACTICE SAFE USE OF MACHINE CONTROLS IN A SAFE AND CLEAR AREA BEFORE YOU OPERATE THIS MACHINE ON A JOB SITE.

It is your responsibility to observe pertinent laws and regulations and to follow manufacturer's instructions on machine operation and maintenance.

See your Authorized Art's-Way Manufacturing Co., Inc. dealer or Art's-Way Manufacturing Co., Inc. for additional operator's manuals, illustrated parts catalogs, and service manuals.

TO THE OWNER

Congratulations on the purchase of your new Art's-Way Beet Tandem High Dump. You have selected a top quality machine that is designed and built with pride to ensure you have many years of efficient and reliable service.

Many people have worked on the design, production, and delivery of this Beet Tandem High Dump. The information in this manual is based on the knowledge, study, and experience through years of specializing in the manufacturing of farm machinery. This manual is designed to provide you with important information regarding safety, maintenance, and machine operation so you can and will get the best possible performance from your Beet Tandem High Dump.

Even if you are an experienced operator of this or similar equipment, we ask that you read this manual before operating this Beet Tandem High Dump. The way you operate, adjust, and maintain this unit will have much to do with its successful performance. Any further questions you may have about this product of Art's-Way equipment should be directed to your local Art's-Way dealer or to Art's-Way Manufacturing Co., Inc. Armstrong, Iowa, 50514, (712) 864-3131.

SPECIFICATIONS AND DESIGN ARE SUBJECT TO CHANGE WITHOUT NOTICE

Art's-Way Manufacturing Co., Inc. is continually making product improvements. In doing so, we reserve the right to make changes and/or add improvements to our products without obligation for the equipment previously sold.

Modifications to this Beet Tandem High Dump may affect the performance, function, and safety of its operation. Therefore, no modifications are to be made without the written permission of Art's-Way Manufacturing Co., Inc. Any modification made without the written permission of Art's-Way Mfg. Co. Inc. shall void the warranty of this product.

In the interest of continued safe operation of this Beet Tandem High Dump, pay particular attention to the safety alert symbol(s) throughout this manual.

Art's-Way Manufacturing Co., Inc. STATEMENT OF PRODUCT LIABILITY

Art's-Way Manufacturing Co., Inc. recognizes its responsibility to provide customers with a safe and efficient product. Art's-Way Manufacturing Co., attempts to design and manufacture its products in accordance with all accepted engineering practices effective at the date of design. This statement should not be interpreted to mean that our products will protect against the user's own carelessness or failure to follow common safety practices nor will Art's-Way Manufacturing Co., be liable for any such act. In addition, Art's-Way Manufacturing Co., assumes no liability for any altered product or any modified product by users or anyone other than an authorized dealer.

IMPORTANT WARRANTY INFORMATION

The warranty for this Beet Tandem High Dump appears on page 6 of this manual. In order to establish proper warranty registration, the Warranty Registration must be completed and returned to the factory. Failure to comply with this requirement will result in invalidating the warranty!

LIMITATIONS OF THIS MANUAL

This manual contains operating instructions for your 9016-BT Beet Tandem High Dump only. Any mention of other machinery in this manual other than the 9016-BT Beet Tandem High Dump is for reference only. This manual does not replace nor is it to be used for any machinery that may be attached to or used in conjunction with the 9016-BT Beet Tandem High Dump.

PARTS & SERVICE

As the purchaser of your new high dump, it is very important to consider the following factors:

A. Original Quality

B. Availability of Service Parts

C. Availability of Adequate Service Facilities

Art's-Way Manufacturing Co., Inc. has an excellent dealership network ready to answer any questions you may have about your high dump. Parts for your machine may be ordered through our dealers. When placing a parts order, please have the **model** and **serial number** ready. This will allow the dealer to fill your order as quickly as possible.

For your convenience, we have provided this space for you to record your model number, serial number, and the date of purchase, as well as your dealer's name and address.

Art's Way
Since 1956

SERIAL NO.

MODEL NO.

**Manufactured by
Art's Way Manufacturing Co., Inc.
Armstrong IA USA**

TABLE OF CONTENTS

TO THE OWNER	1
SPECIFICATIONS AND DESIGN ARE SUBJECT TO CHANGE WITHOUT NOTICE	1
Art's-Way Manufacturing Co., Inc. STATEMENT OF PRODUCT LIABILITY	1
IMPORTANT WARRANTY INFORMATION	1
LIMITATIONS OF THIS MANUAL	1
PARTS & SERVICE	2
TABLE OF CONTENTS	3-5
LIMITED WARRANTY	6
SAFETY FIRST	7
NOTICES OF DANGER, WARNING, AND CAUTION	7
<u>Safety Instructions</u>	8
GENERAL	8
BEFORE OPERATING	9
DURING OPERATION	9
MAINTENANCE SAFETY	9
HYDRAULIC SAFETY	10
TRANSPORTATION SAFETY	10
STORAGE SAFETY	10
TIRE SAFETY	11
ASSEMBLY SAFETY	11

TABLE OF CONTENTS	
NAME	PAGE
HIGH DUMP ASSEMBLY	16
WEIGHTBOX ASSEMBLY	18
DECALS	20
HYDRAULICS	23
RUNNING GEAR ASSEMBLY	26
HUB AND SPINDLE ASSEMBLY	28
WHEEL ASSEMBLY	30
TANK, ELEVATOR ASSEMBLY	34
ELEVATOR, ROLLER ASSEMBLY	36
FRAME, ROLLER ASSEMBLY	38
ELEVATOR, CYLINDER ASSEMBLY	40
FRAME - ELEVATOR, CYLINDER ASSEMBLY	42
FRAME, HYDRAULIC BLOCK ASSEMBLY	44
TANK, GUARD ASSEMBLY	46



LIMITED WARRANTY FOR NEW ART'S WAY MANUFACTURING CO. FARM MACHINERY (U.S. ONLY)

- A. GENERAL PROVISIONS:** Art's Way Manufacturing Co., Inc. (Art's Way Mfg.) warrants the products it sells to be free from defects in material and workmanship for the periods of time set forth in the Warranty Table below. Art's Way Mfg. obligation and liability under this limited warranty, is to repair or replace (at Art's Way Mfg. option) any part(s) that upon manufacture were defective in material or workmanship. Warranty service shall be performed by an authorized Art's Way Mfg. dealer or authorized service center and will be completed using Art's Way Mfg. supplied parts. Parts supplied by Art's Way Mfg. are shipped F.O.B. Art's Way. The original purchaser shall be responsible for service calls and transportation of the farm machinery to and from their dealer or service center. The original purchaser is also responsible for any expedited repair charges (i.e., overtime and "next day air" deliveries) requested by the original purchaser. The original purchaser is also responsible for any repair service, parts, and labor on repairs made to the farm machinery at the time the warranty service was being performed.
- B. SECURING WARRANTY SERVICE:** The original purchaser must (1) contact their authorized dealer and report the break-down. (2) The authorized dealer shall provide objective evidence of the farm machinery's warranty status to Art's Way Mfg. (3) The authorized dealer shall provide all documentation to Art's Way Mfg. which supports that the farm machinery was thoroughly inspected prior to set-up and delivery to the original purchaser. (4) The original purchaser shall make the farm machinery available to their Art's Way Mfg. authorized dealer and/or Art's Way Mfg. authorized service center within 30 days of the reported break-down. All parts or assemblies replaced under the limited warranty must be held for inspection for ninety (90) days, or until credit has been issued, or a claim has been returned to a dealer. When a claim is returned to a dealer with instructions to return and/or hold the part(s) for inspection, parts must be handled as instructed or the claim may be denied.
- C. SPARE PARTS WARRANTY:** Art's Way Mfg. warrants that it will replace or repair (excluding labor) as Art's Way Mfg. elects, without charge, any genuine spare part purchased from Art's Way Mfg. which is defective in material or workmanship within ninety (90) days of the date of installation. This warranty applies to parts that, in Art's Way Mfg. judgement, prove to be defective in either material or workmanship. All parts to be shipped F.O.B. Art's Way Mfg. All spare parts replaced under the spare parts warranty must be held for inspection for ninety (90) days or until credit has been issued, or a claim has been returned to a dealer. When a claim is returned to a dealer with instructions to return and/or hold the part(s) for inspection, parts must be handled as instructed or the claim may be denied.
- D. LIMITATIONS:** Art's Way Mfg. Limited Warranty does not extend coverage to product being used in a commercial application (i.e. rented equipment). Art's Way Mfg. Limited Warranty does not extend to parts and elements not manufactured by Art's Way Mfg., and which carry the warranty of another manufacturer. Art's Way Mfg. makes no other warranty expressed or implied and makes no warranty of merchantability or fitness for any particular purpose beyond that expressly stated in this warranty. Art's Way Mfg. liability is limited to the terms set forth in this warranty and does not include any liability for direct, indirect, incidental or consequential damages or expenses of delay and Art's Way Mfg. liability is limited to the repair and replacement of defective parts as set forth herein. Any improper use and/or maintenance, including operation after the discovery of defective or worn parts, operation beyond the rated capacity, substitution of parts not approved by Art's Way Mfg. or any alteration or repair by others than the authorized Art's Way Mfg. dealer or authorized service center which affect the product materially and adversely, shall void the warranty. No dealer, employee or representative is authorized to change this warranty in any way or grant any other warranty unless such change is made in writing and signed by an officer of Art's Way Mfg. Some states do not allow limitations on how long an implied warranty lasts or exclusions or limitations of incidental or consequential damages, so the above limitations or exclusions may not apply to you. This warranty gives you the specific legal rights, and you may have other rights that vary from state to state.

NOTE: As of April 1, 2015, all previously distributed information concerning the limited warranty coverage of any Art's Way Manufacturing Company, Inc. manufactured product is to be considered null and void and replaced by this document.

Art's Way Mfg. Farm Machinery	Warranty Coverage
Grinder / Mixer – Model 6520, 6530, 6140, 6105, and Portable and Stationary equipment	1 (one) Year from Date of Delivery to Original Purchaser
Manure Spreader	1 (one) Year from Date of Delivery to Original Purchaser
Graders and Land Planes	1 (one) Year from Date of Delivery to Original Purchaser
Beet Harvesting Machinery	1 (one) Harvest Season from Date of Delivery to Original Purchaser
Shredders – Model 180C and 240C	1 (one) Year from Date of Delivery to Original Purchaser
Plows	1 (one) Year from Date of Delivery to Original Purchaser
Forage Blowers – Model 1060 and 2060	1 (one) Year from Date of Delivery to Original Purchaser
Forage Boxes/Receivers – Model 5300 and 1250	1 (one) Year from Date of Delivery to Original Purchaser
Rakes	1 (one) Year from Date of Delivery to Original Purchaser
Dump Boxes	1 (one) Year from Date of Delivery to Original Purchaser
Augers	1 (one) Year from Date of Delivery to Original Purchaser
Running Gear	1 (one) Year from Date of Delivery to Original Purchaser
Snow Blowers	1 (one) Year from Date of Delivery to Original Purchaser
Harvester Reel	1 (one) Year from Date of Delivery to Original Purchaser

SAFETY FIRST

SAFETY INSTRUCTIONS

“A careful operator is the best insurance against an accident.” Quote from the National Safety Council.

Most accidents can be prevented if the operator:

1. Fully understands how the machine functions.
2. Can anticipate situations which may produce problems.
3. Can make necessary corrections before problems develop.

**THIS SYMBOL MEANS ATTENTION!
BECOME ALERT!
YOUR SAFETY IS INVOLVED!**



- Universal Safety Alert Symbol

The American Society of Agricultural Engineers has adopted the Universal Safety Alert Symbol as a way to identify areas of potential danger if the equipment is not operated correctly. Please be alert whenever you see this symbol in the manuals or on your high dump.

Art's-Way Manufacturing Co., Inc. strives to make our equipment as safe as possible. The Art's-Way 9016-BT Beet Tandem High Dump conforms to applicable safety standards at the time of manufacturing. A safety conscious equipment operator makes an effective accident-prevention program complete.

Safety features and instructions for the high dump are detailed in the Safety Guidelines section of this Operator's Manual. It is the responsibility of the owner to ensure that all operators read and understand the manual before they are allowed to operate the High Dump. (Occupational Safety and Health Administration (OSHA) regulations 1928.57).

NOTICES OF DANGER, WARNING, AND CAUTION

Signal Words: Note the use of signal words **DANGER**, **WARNING**, and **CAUTION** on the high dump and in this manual. The appropriate signal word for each has been selected using the following guidelines:

⚠ DANGER

Indicates a hazardous situation which, if not avoided, will result in death or serious injury.

⚠ WARNING

Indicates a hazardous situation which, if not avoided, could result in death or serious injury.

⚠ CAUTION

Indicates a potentially hazardous situation which, if not avoided, could result in minor or moderate injury.

NOTICE

NOTICE is used to address practices not related to physical injury.

SAFETY INSTRUCTIONS

Safety instructions (or equivalent) signs indicate specific safety-related instructions or procedures.

Note: Contains additional information important to a procedure and will be found within the regular text body of this manual.

SAFETY INSTRUCTIONS

GENERAL

Most work related accidents are caused by failure to observe basic safety rules or precautions. An accident can often be avoided by recognizing potentially hazardous situations before an accident occurs. As you operate and maintain the High Dump you must be alert to potential hazards. You should also have the necessary training, skills, and tools to perform any assembly procedure.

Improper operation and/or maintenance of this unit could cause a dangerous situation that results in injury or death.

Do not use this unit until you read and understand the information contained in this manual. Do not use this equipment for anything other than its intended purpose.



Safety precautions and warnings are provided in this manual and on the unit. If these hazard warnings are not heeded, bodily injury or death could occur to you or to other persons.

Art's-Way Manufacturing Co., Inc. cannot anticipate every possible circumstance that might involve a potential hazard. The warnings in this manual and on the product are, therefore, not all-inclusive. If a method of operation not specifically recommended by us is used, you must satisfy yourself that it is safe for you and for others. You should also ensure that the unit will not be damaged or be made unsafe by the methods that you choose.

The information, specifications, and illustrations in this manual are based on the information that was available at the time this material was written and can change at any time.

Safety Alert Symbols



death.

This is the safety alert symbol. It is used to alert you to potential personal injury hazards. Obey all safety messages that follow this symbol to avoid possible injury or

This manual contains DANGERS, WARNINGS, CAUTIONS, NOTICES, SAFETY INSTRUCTIONS, and NOTES which must be followed to prevent the possibility of improper service, damage to the equipment, personal injury, or death. The following key words call the readers attention to potential hazards.

Hazards are identified by the "Safety Alert Symbol" and followed by a signal word such as "DANGER", "WARNING", or "CAUTION".

**SAFETY
INSTRUCTIONS**

Remember:
"The Best Operator is a Safe Operator"

CAUTION



Read and understand the operator's manual and all the safety decals before operating the high dump. Review all safety instructions with all operators annually.

BEFORE OPERATING

SAFETY
INSTRUCTIONS

Do not wear loose fitting clothing as it may catch in moving parts.



Make sure all guards and shields are installed, including the tractor power take-off (PTO) master shield, before starting or operating the high dump.



Be sure that the correct implement driveline parts are used and that they are properly secured.

Lower the lifter wheels when the high dump is not in use.

Install safety chain when attaching the high dump to the tractor.



Clear the area of bystanders, especially children, when making repairs, adjustments, or performing maintenance on the high dump.



Do not allow riders.

Put all tractor and machine controls in “neutral” and disengage the PTO before starting. Follow the starting instructions according to the OEM tractor manual.



Operate the high dump only while seated on the tractor seat.



Make sure the unit is adequately supported with safety blocks or safety stands when changing tires or performing maintenance.

DURING OPERATION

CAUTION



Entanglement Hazard
Keep hands, feet, hair, and clothing away from moving parts. Wait for all movement to

stop before approaching equipment. Before making adjustments:

1. Shut off the tractor,
2. Set parking brake,
3. Put machine in neutral, and
4. Remove key while making adjustments.



Keep all shields and guards in place and in good working condition.



Keep all bystanders, especially children, away from the high dump while in operation.



Do not allow riders while the high dump is in operation.



Do not attempt to unclog, clean, or adjust the high dump while it is running.



Stay away from overhead power lines. Electrocution can occur even without direct contact.



Keep all hydraulic lines, fittings, and couplers tight and free of leaks. (Refer to Safety Guidelines – Hydraulic Safety).



Use caution when ascending or descending on the high dump. Wet shoes or boots are slippery.

MAINTENANCE SAFETY

SAFETY
INSTRUCTIONS

Follow all operating, maintenance, and safety instructions found in this Manual.



Before servicing, adjusting, repairing, or unclogging the machine, always make sure the tractor engine is stopped, key in your pocket, the machine is lowered to the ground, all controls are placed in neutral, the parking brake is set, and all the moving parts have stopped.



Use sufficient tools, jacks, and hoists that have the capacity for the job.



Use support blocks or safety stands when changing tires or performing maintenance.



Follow good shop practices of keeping the service area clean and dry, and use adequate light for the job at hand.



Before applying pressure to the hydraulic system, make sure all lines, fittings, and couplers are tightly secured and in good condition.



Make sure all shields/guards are in place and properly secured when performing maintenance.

HYDRAULIC SAFETY

SAFETY INSTRUCTIONS

Follow all operating, maintenance, and safety instructions found in this Manual.

Make sure components in the hydraulic system are kept clean and in good working condition.



Relieve pressure from the hydraulic system before servicing or disconnecting from the tractor.



Keep all hydraulic lines, fittings, and couplers tightly secured and free of leaks.



Replace any worn, cut, abraded, flattened, or crimped hoses.



Do not make any temporary repairs to the hydraulic lines, fittings, or hoses using tape, clamps, or cement. The hydraulic system operates under extremely high pressure and temporary repairs may fail suddenly and create a hazardous/dangerous situation.



Wear proper hand and eye protection when searching for a high-pressure hydraulic leak. Use a piece of wood or cardboard as a backstop instead of hands to identify and isolate a leak. If injured by a concentrated high-pressure stream of hydraulic fluid, seek medical attention immediately. Serious infection or toxic reaction can develop if hydraulic fluid penetrates the surface of the skin.



Before applying pressure to the system, make sure all components are tight and that the hydraulic lines, hoses, and couplings are not damaged.

TRANSPORTATION SAFETY

SAFETY INSTRUCTIONS

Follow all operating and safety instructions found in this manual when transporting this equipment.

Make sure the high dump complies with all local regulations regarding transporting equipment on public roads and highways.



Make sure the Slow Moving Vehicle (SMV) emblem and all lights and reflectors required by local highway and transportation authorities are properly in place, clean, and clearly visible to traffic.



Do not allow riders on any machinery during transport.

Make sure the high dump is securely attached to the tractor and install a safety chain to the high dump.

Make sure the tractor brake pedals are latched together.

Do not exceed 20 mph (32 km/h) when transporting the high dump. Always reduce speed on rough roads and surfaces, or when going down inclines.

Use caution when turning and always use the turn signals on the tractor to indicate your turning intentions to the other traffic.

The weight of the trailed machine should NEVER exceed the weight of the towing vehicle.

Check all clearances carefully whenever the machine is towed.

Lower the elevator into the transport position before transporting the high dump on the highway.



Stay away from overhead obstructions and power lines during transport. Electrocutation can occur even without direct contact.

STORAGE SAFETY

SAFETY INSTRUCTIONS

Follow all operating and safety instructions found in this manual when storing this equipment.



Store the high dump in an area away from human activity.



Do not permit children to play on or around the stored machine at any time.

Make sure that the high dump is stored in an area with a firm and level base to prevent the machine from tipping or sinking into the ground.



Block the wheels to prevent the machine from rolling.

TIRE SAFETY**SAFETY
INSTRUCTIONS**

Follow all operating and safety instructions found in this manual when working around tires.

Have only a qualified tire dealer or tire repair service perform tire repairs.

Do not attempt to install a tire on a wheel or rim unless you have the proper equipment and experience to do the job.

Do not substitute tires with a lesser road rating and/or capacity for the original equipment tires.

WARNING

Explosive Force Hazard
Tire replacement, repair, and/or maintenance should be done by a qualified tire dealer or qualified repair service.

Failure to follow proper procedures when installing a tire on a wheel or rim can produce an explosive force that will result in serious injury or death.

Do not attempt to install a tire without proper equipment and experience to perform the job.

ASSEMBLY SAFETY**SAFETY
INSTRUCTIONS**

Follow all assembly, operating, and safety instructions found in this manual when assembly this equipment.



Use adequate manpower to perform assembly procedures safely.

Assemble the high dump in an area with sufficient space to maneuver the largest components and allow easy access to all sides of the machine.



Use only forklifts, lift cranes, jacks, and tools with sufficient capacity for the loads.



Do not allow spectators, especially children, in the working area.

**THIS PAGE
LEFT
INTENTIONALLY
BLANK**

SECTION 1: OPERATOR'S MANUAL

**THIS PAGE
LEFT
INTENTIONALLY
BLANK**

SECTION 2: ILLUSTRATED PARTS LIST - FULL ASSEMBLY

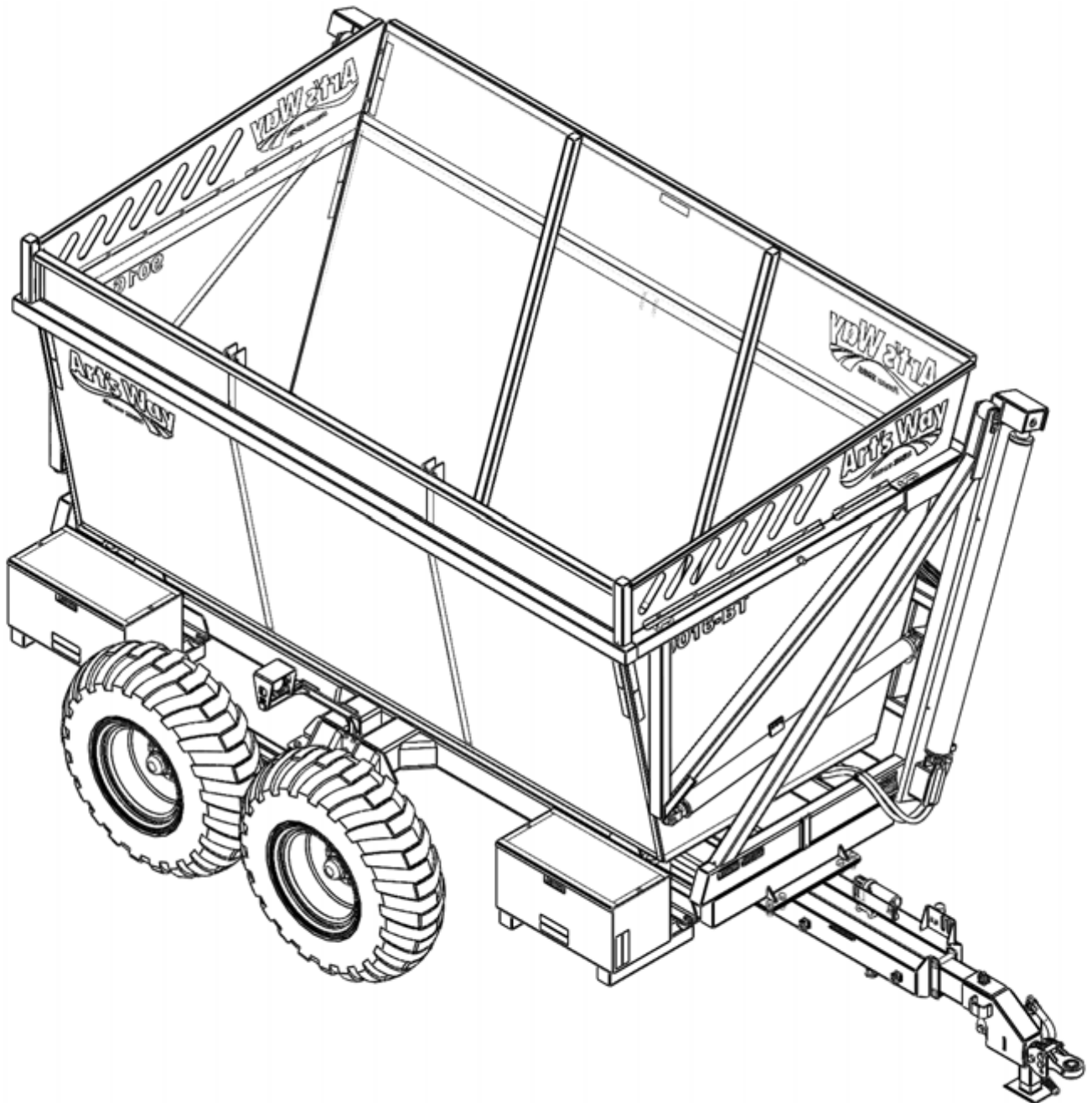

HIGH DUMP ASSEMBLY

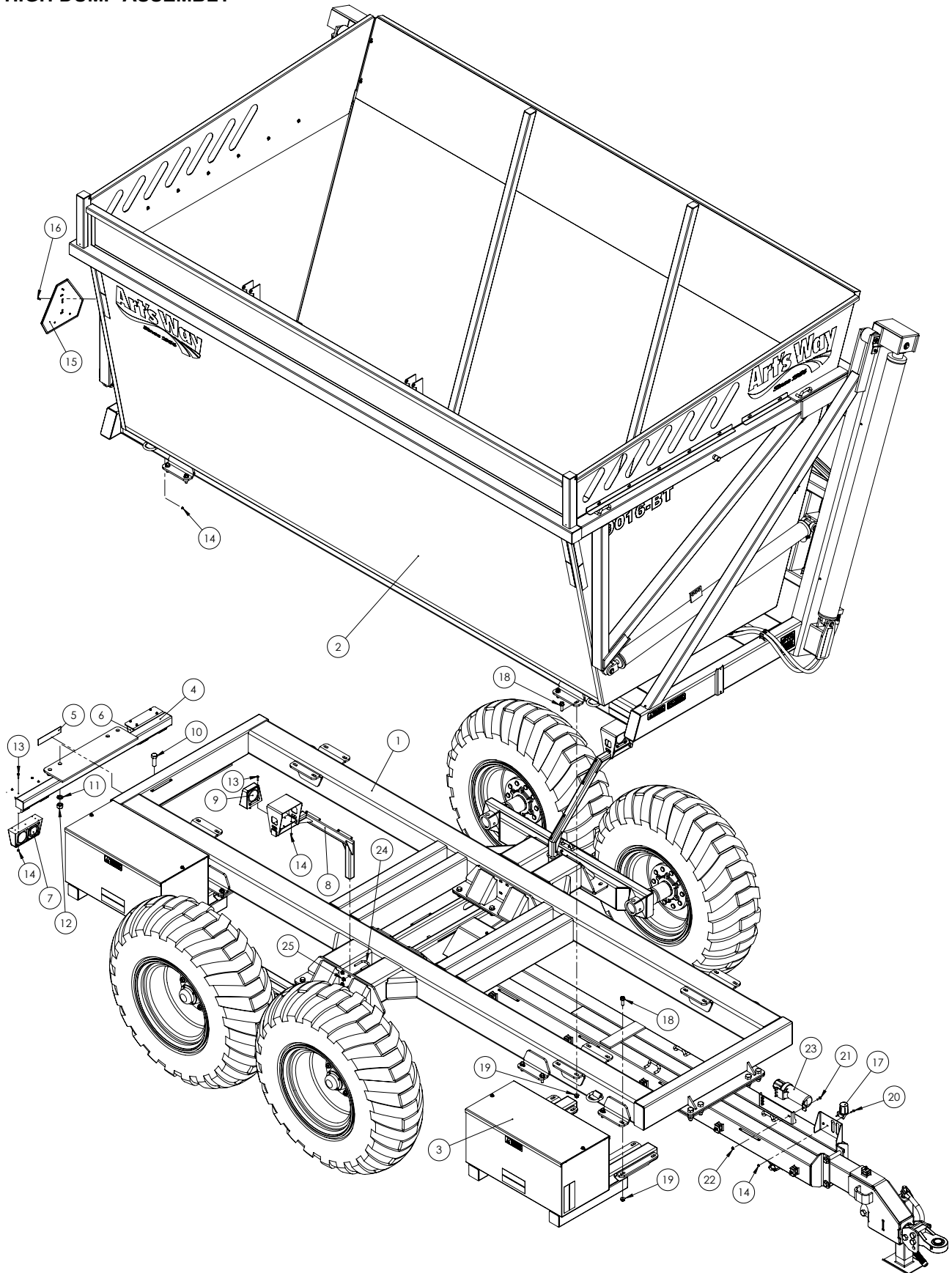

ITEM NO.	PART NUMBER	DESCRIPTION	QTY.
1	619800	ROLLING CHASIS W/SCALE	1
2	617960	DUMP BOX ASSY	1
3	618250	WEIGHT BOX ASSY	2
4	619090	LIGHT BAR, REAR	1
5	476450	TAPE, RED RETROREFLECTIVE	1
6	619730	LAMP ASSY, LH DUAL	1
7	619740	LAMP ASSY, RH DUAL	1
8	619060	MOUNT, AMBER LIGHT	2
9	619710	LAMP ASSY, AMBER LED	2
10	497590	BOLT, HHCS 1-8 X 3 GR8	4
11	003350	WASHER, LOCK 1"	4
12	J14H805	NUT, HEX 1-8	4
13	600090	BOLT, HFH 1/4-20	16
14	600100	NUT, HFH NYLOC 1/4-20	20
15	E224138	EMBLEM, CAUTION SMV	1
16	I159920	SCREW, RHMS 1/4-20X3/4 ZN	2
17	JPT1296	BRACKET, STORAGE HOLDER 7 POLE	1
18	600300	BOLT, HFH 5/8-11	32
19	600150	NUT, HFH NYLOC 5/8-11	32
20	600020	BOLT, HFH 1/4-20	2
21	600060	BOLT, HFH 5/16-18 X 1"	4
22	600110	NUT, HFH NYLOC 5/16-18	4
23	MP907739	TUBE - OP MAN HOLDER	1
24	290890	BOLT, U	4
25	600140	NUT, HFH NYLOC 1/2-13	8

WEIGHTBOX ASSEMBLY

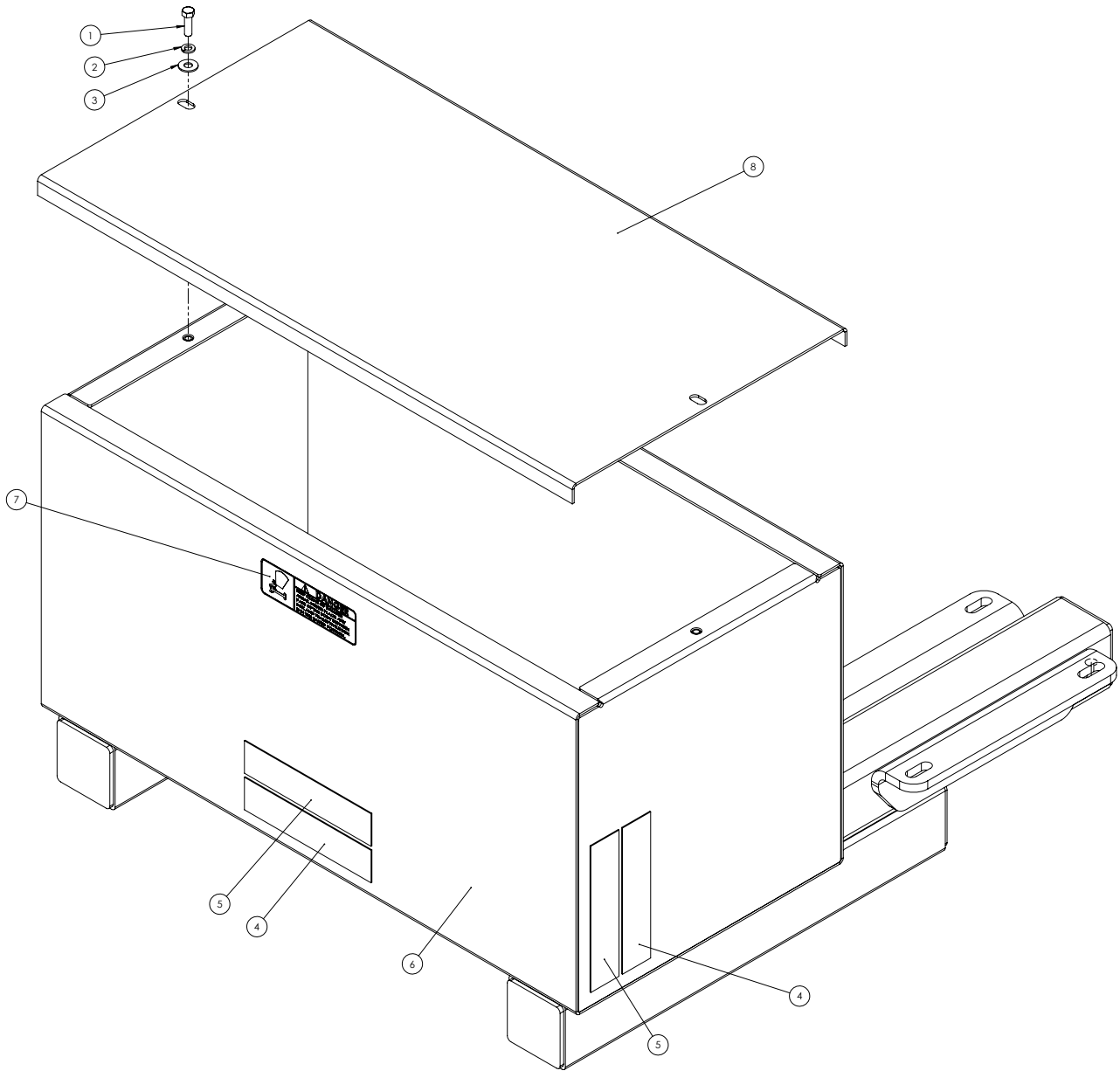

ITEM NO.	PART NUMBER	DESCRIPTION	QTY.
1	006690	BOLT, HHCS 3/8-16 X 1-1/4	2
2	021180	WASHER, LOCK 3/8	2
3	021190	WASHER, FLAT 3/8 STD	2
4	476450	TAPE, RED RETROREFLECTIVE	3
5	476460	TAPE, YELLOW RETROREFLECTIVE	3
6	618210	WEIGHT BOX WELDMENT	1
7	MP19.00113	DECAL, DANGER	1
8	MP19.00937.7	COVER, WEIGHT BOX	1

DECALS

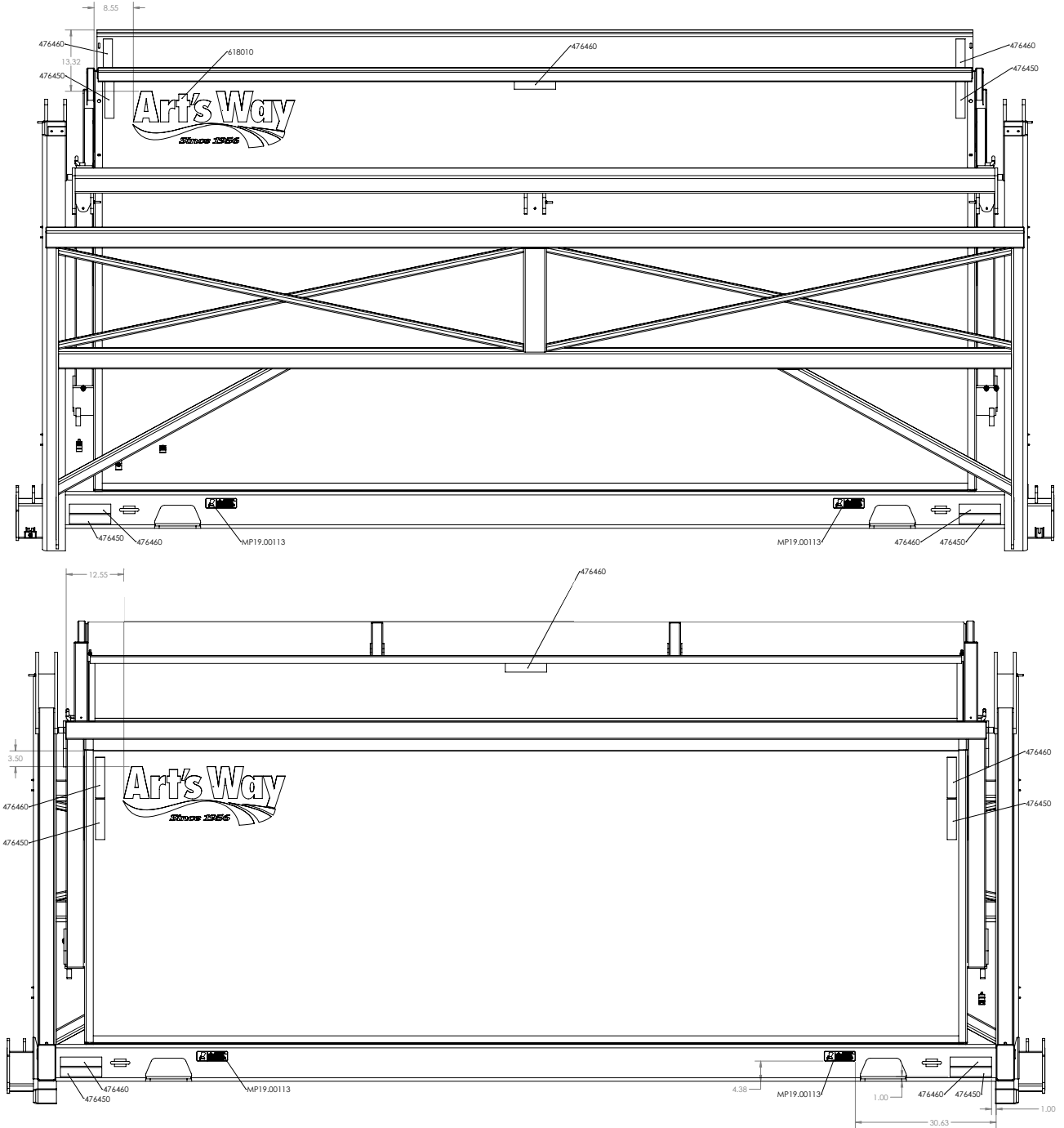

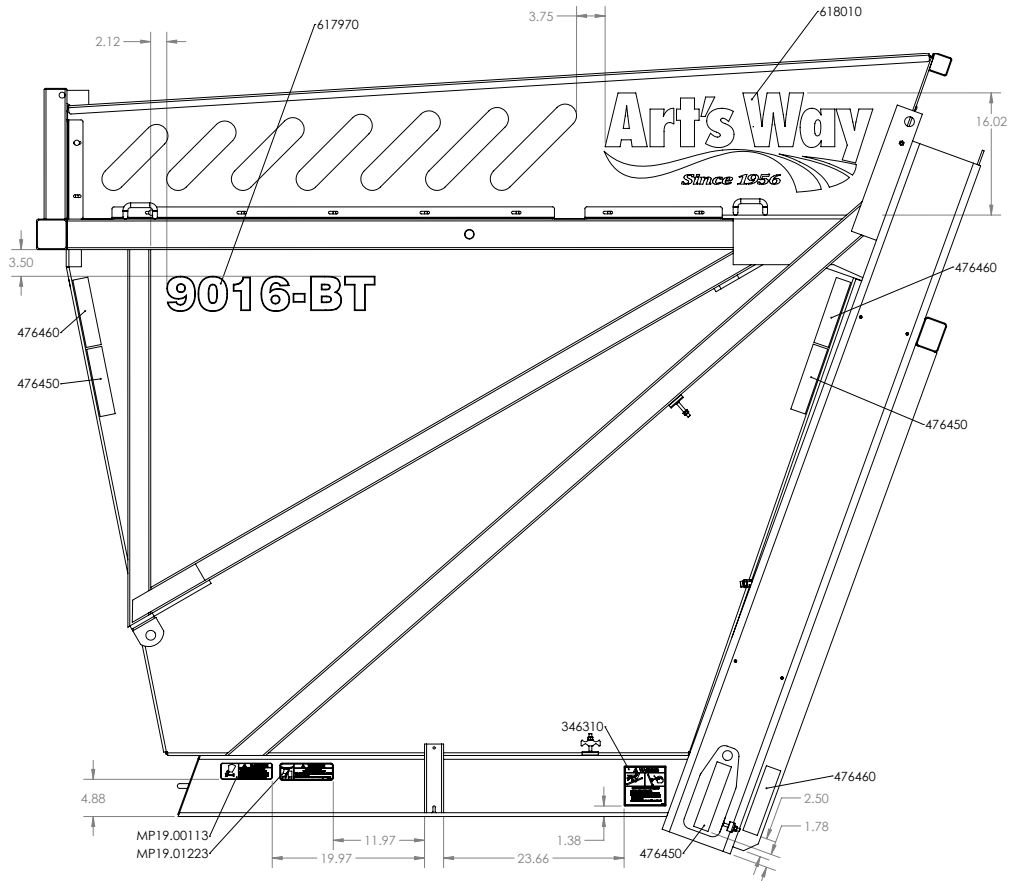
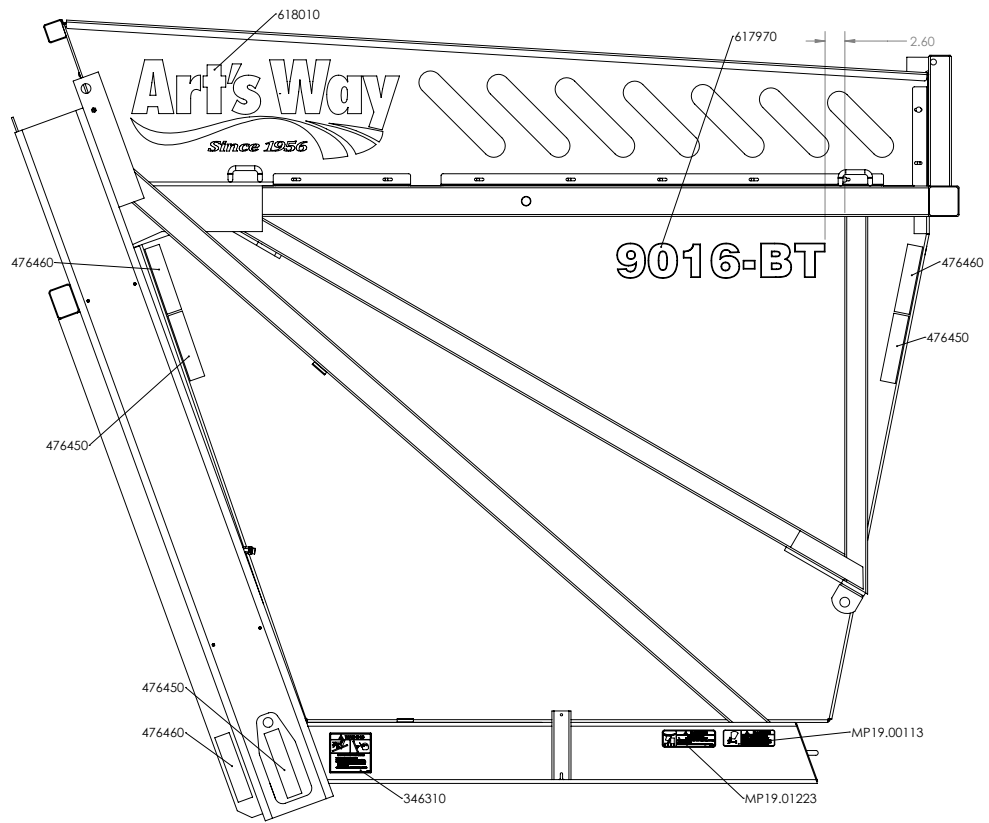

**THIS PAGE
LEFT
INTENTIONALLY
BLANK**

HYDRAULICS

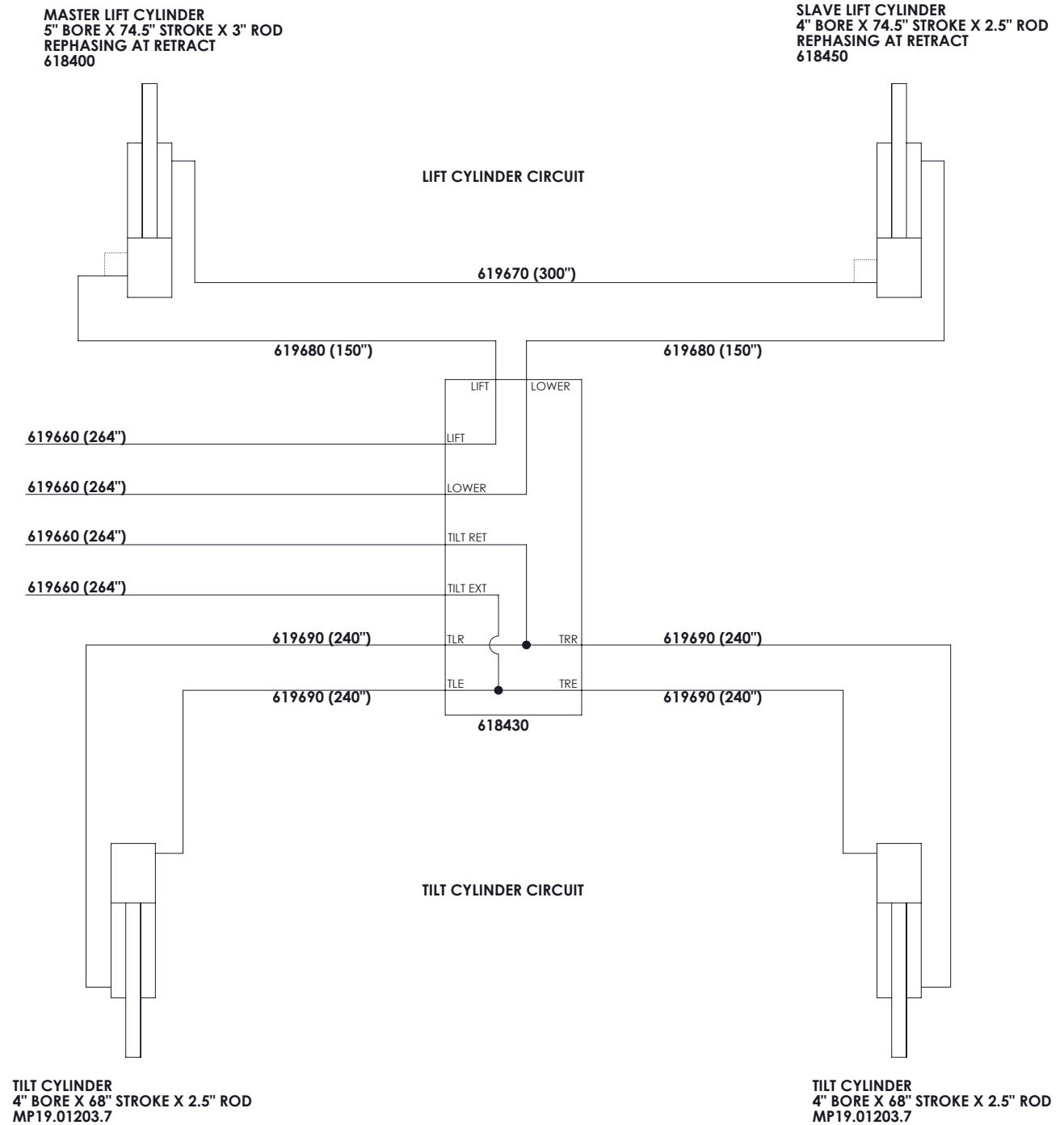

**THIS PAGE
LEFT
INTENTIONALLY
BLANK**

SECTION 2: ILLUSTRATED PARTS LIST - RUNNING GEAR

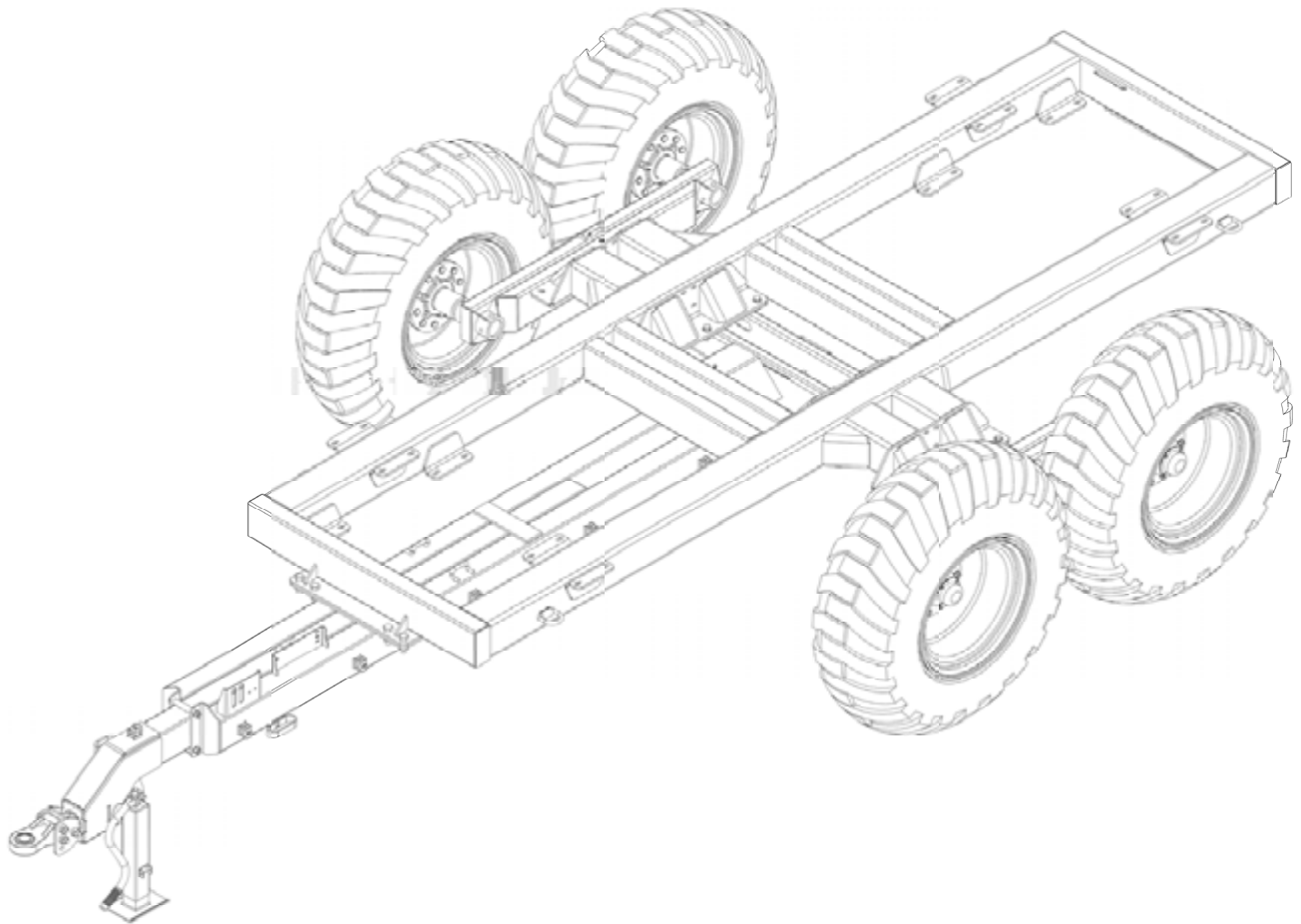

RUNNING GEAR ASSEMBLY

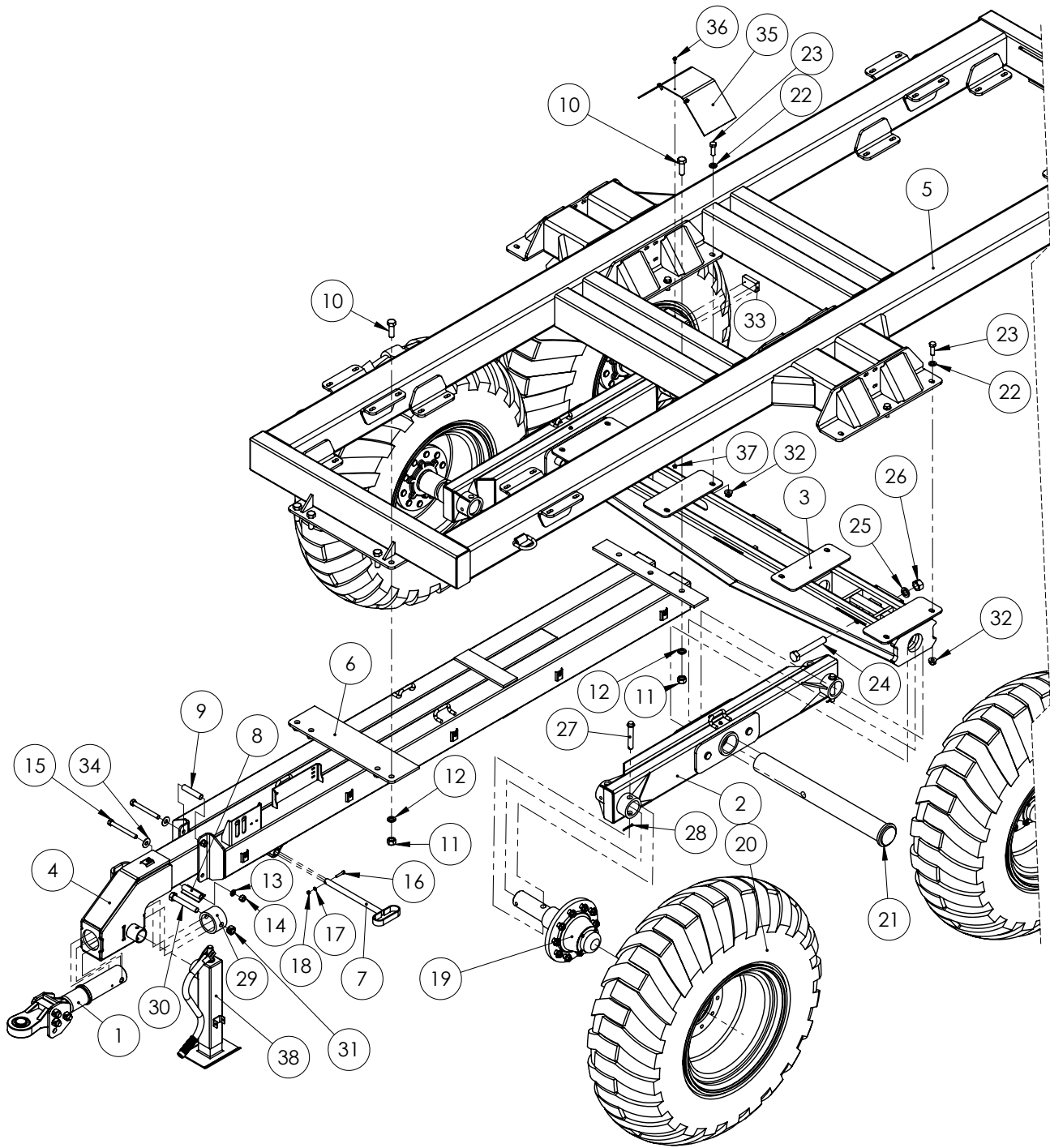

ITEM NO.	PART NUMBER	DESCRIPTION	QTY.
1	619810	HITCH ASSY, W/SCALE	1
2	618150	BEAM, WALKING TANDEM	2
3	618040	BEAM, AXLE SUPPORT	1
4	618350	TONGUE WLDT	1
5	618020	FRAME WELDMENT	1
6	618130	HITCH SUPPORT	1
7	MP19.01259	PIN WLDT, HITCH	1
8	MP19.01270	TUBE, PIN	1
9	MP19.01268	TUBE	1
10	497590	BOLT, HHCS 1-8 X 3 GR8	7
11	J14H805	NUT, HEX 1-8	7
12	003350	WASHER, LOCK 1"	7
13	036800	WASHER, LOCK 3/4 SAE	2
14	036750	NUT, HEX 3/4-10	2
15	479980	BOLT, HHCS 3/4-10 X 7 GR 8 ZN	2
16	037790	BOLT, HHCS 3/8-16 X 2	1
17	021180	WASHER, LOCK 3/8	1
18	027260	NUT, HEX 3/8-16 GR5 ZN	1
19	619890	HUB/SPINDLE	4
20	HN69-07-4019	WHEEL, 16R20 USED	4
21	H160009	PIVOT PIN ASSY	2
22	600330	WASHER,FLAT 3/4	8
23	600340	BOLT, HHCS	8
24	HZ85-03-2080	BOLT, HEX, 1-1/4" X 8" Z8	2
25	E829047	WASHER, LOCK 1-1/4	2
26	HZ85-42-2020	NUT, LOCK, DEFORMED, 1-1/4"-7 Z8	2
27	H160017	SPINDLE PIN ASSY (TANDEM)	4
28	114370	PIN, COTTER, 1/4" X 2" Z5	2
29	H160077	SWIVEL HITCH STOP	1
30	J08H4722	BOLT, HHCS 1-8 X 6 1/2 GR8 ZN	1
31	990510	NUT, LOCK 2-WAY 1-8	1
32	600160	NUT, HFH TOPLOCK 3/4-10	8
33	619830	JUNCTION BLOCK, 6 PORT	1
34	990710	WASHER, FLAT 3/4 STD	2
35	526720	DEFLECTOR, RUBBER	1
36	600060	BOLT, HFH 5/16-18 X 1"	3
37	600110	NUT, HFH NYLOC 5/16-18	3
38	U51800143	JACK	1

HUB AND SPINDLE ASSEMBLY

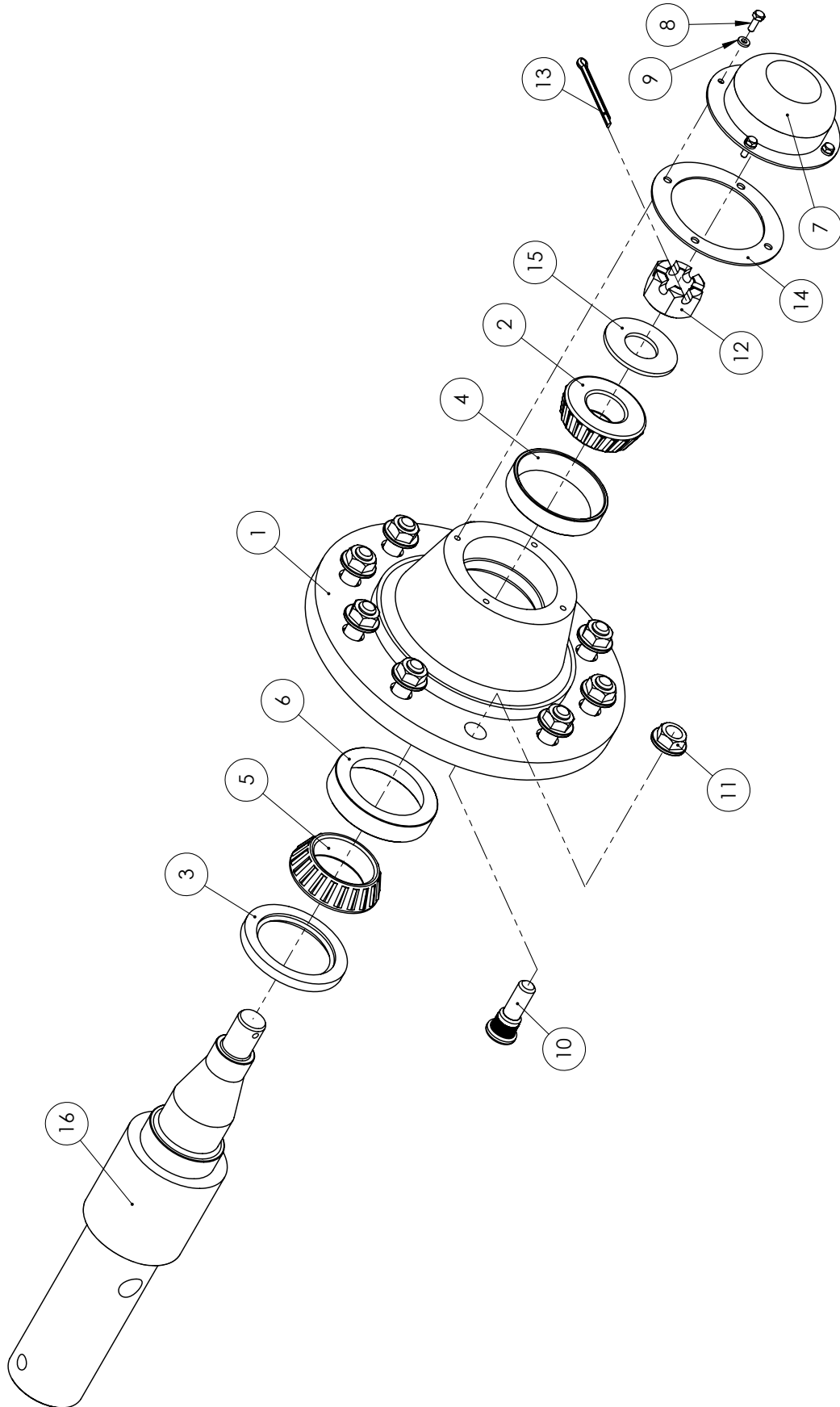

ITEM NO.	PART NUMBER	DESCRIPTION	QTY.
1	HN69-05-4072	873 HUB MACHINED CASTING	1
2	HN69-02-4045	OUTSIDE BEARING #460	1
3	HN69-02-4028	GREASE SEAL #33464 SA	1
4	HN69-02-4068	OUTSIDE BEARING RACE #453A	1
5	HN69-02-4064	INSIDE BEARING #33275	1
6	HN69-02-4066	INSIDE BEARING RACE #33462	1
7	HN69-02-4030	4-BOLT DUST CAP	1
8	HZ82-03-0412	1/4" HEX HEAD BOLT, .75"	4
9	HZ82-66-0404	WASHER, LOCK SPLIT, 1/4" Z5	4
10	HN69-02-4061	WHEEL, STUD 3/4"	10
11	HN69-02-4042	3/4" LUG NUT	10
12	E552023	NUT, SLOTTED 1-1/4 12 GR5	1
13	MP906827	.25"X 3" COTTER PIN	1
14	455750P	GASKET, HUB	1
15	R61502	FW 1.375	1
16	619880	LOAD CELL SPINDLE	1

WHEEL ASSEMBLY

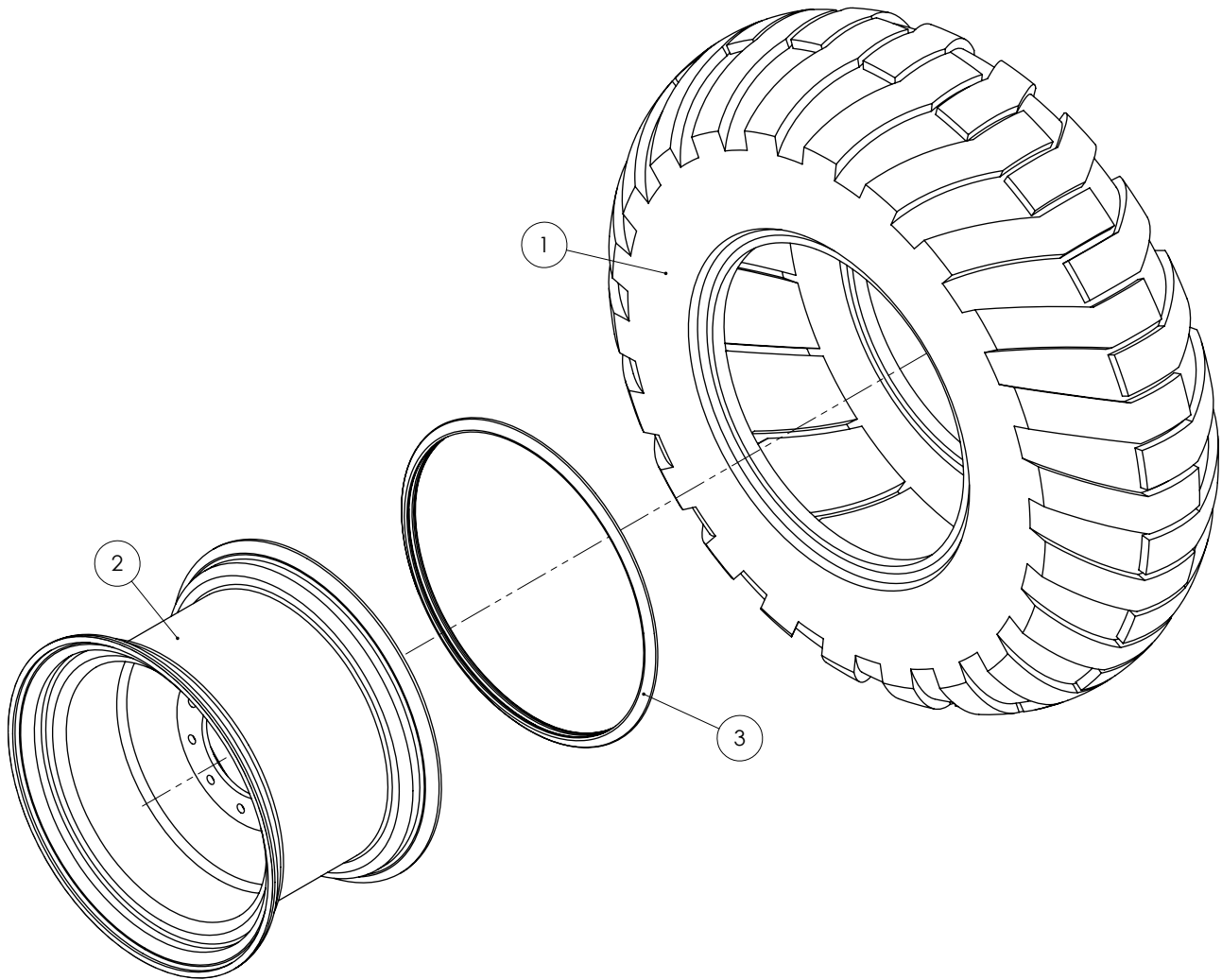

ITEM NO.	PART NUMBER	DESCRIPTION	QTY.
1	HN69-07-4073	20.5 X 25 TIRE	1
2	HN69-07-4074	RIM	1
3	606100	L RING, WHEEL LOCKING	1

**THIS PAGE
LEFT
INTENTIONALLY
BLANK**

SECTION 2: ILLUSTRATED PARTS LIST - TANK & LIFT

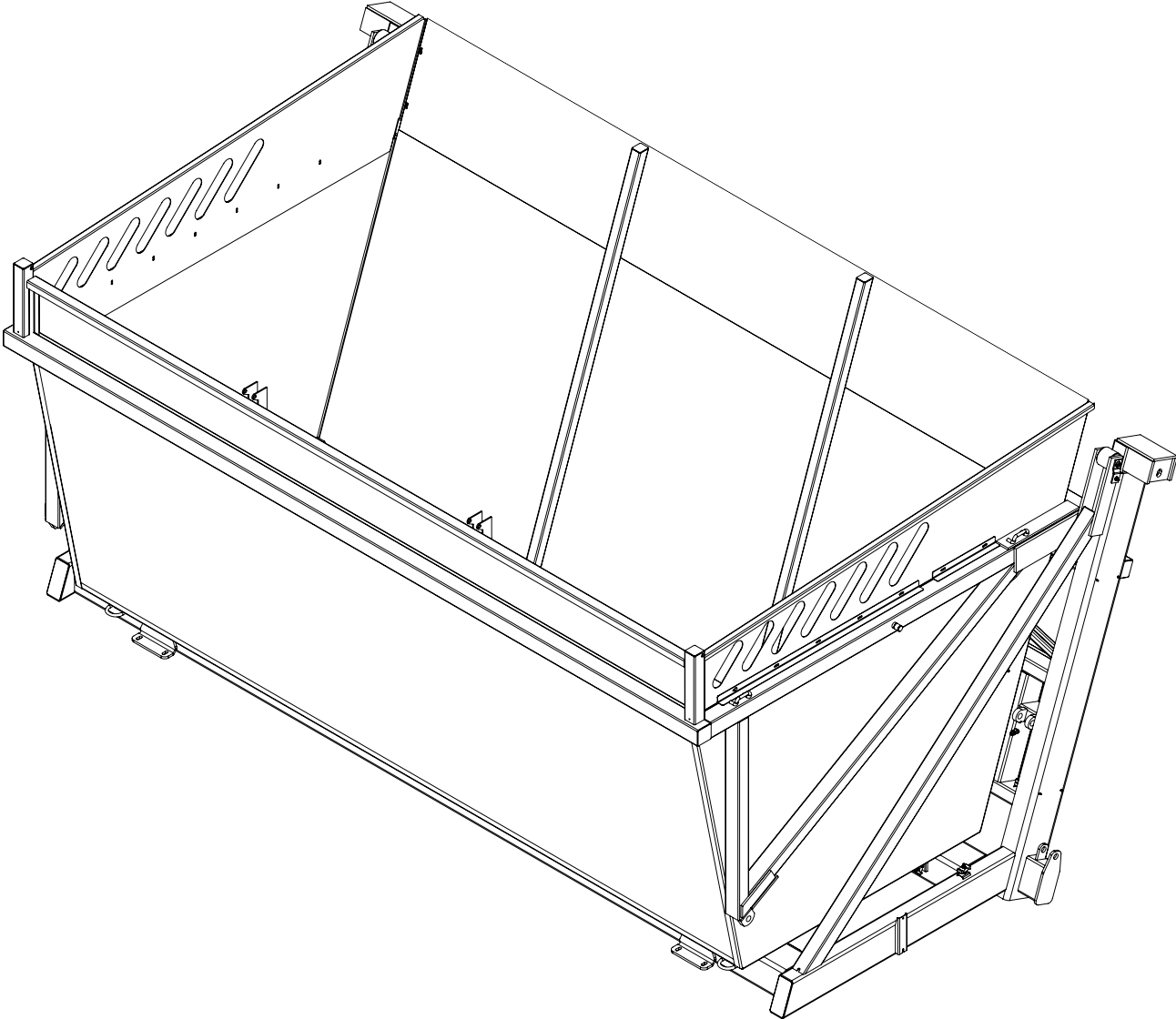

TANK, ELEVATOR ASSEMBLY

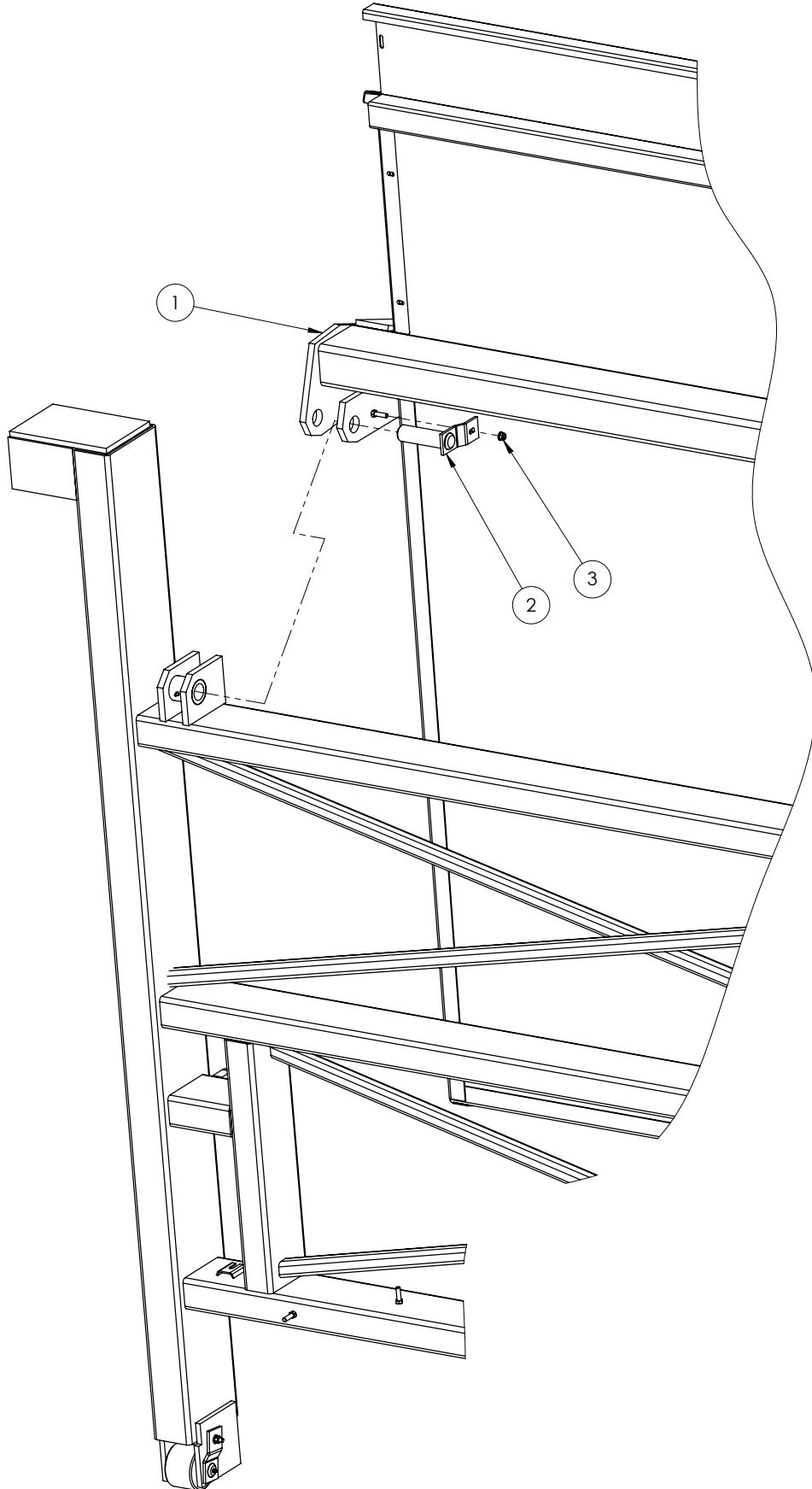

ITEM NO.	PART NUMBER	DESCRIPTION	QTY.
1	618420	TANK WELDMENT, 9016 GREEN	-
2	MP19.00639	PIN, TANK PIVOT	-
3	600120	NUT, HFH NYLOC 3/8-16	-

ELEVATOR, ROLLER ASSEMBLY

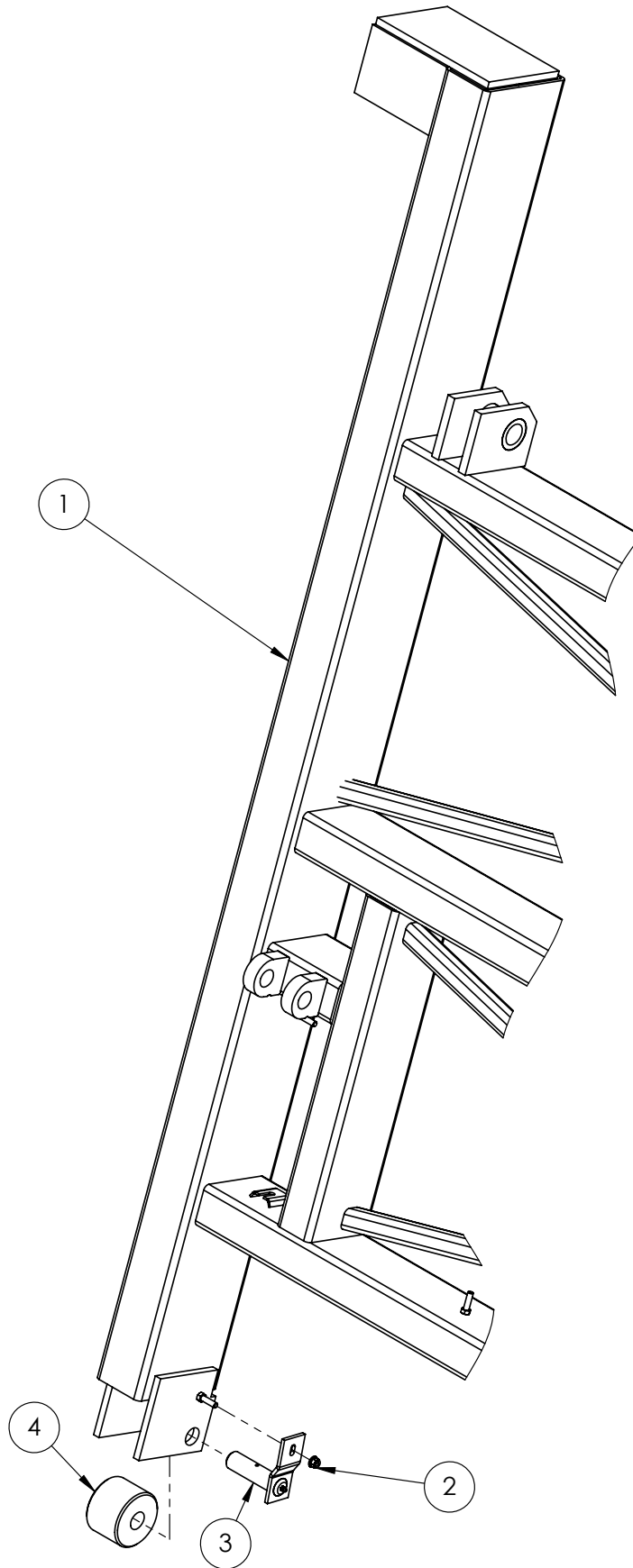

ITEM NO.	PART NUMBER	DESCRIPTION	QTY.
1	MP19.00484.1	ELEVATOR ASSEMBLY	-
2	600120	NUT, HFH NYLOC 3/8-16	-
3	MP19.00644	PIN ASSEMBLY	-
4	MP19.00454.7	ROLLER, BOTTOM	-

FRAME, ROLLER ASSEMBLY

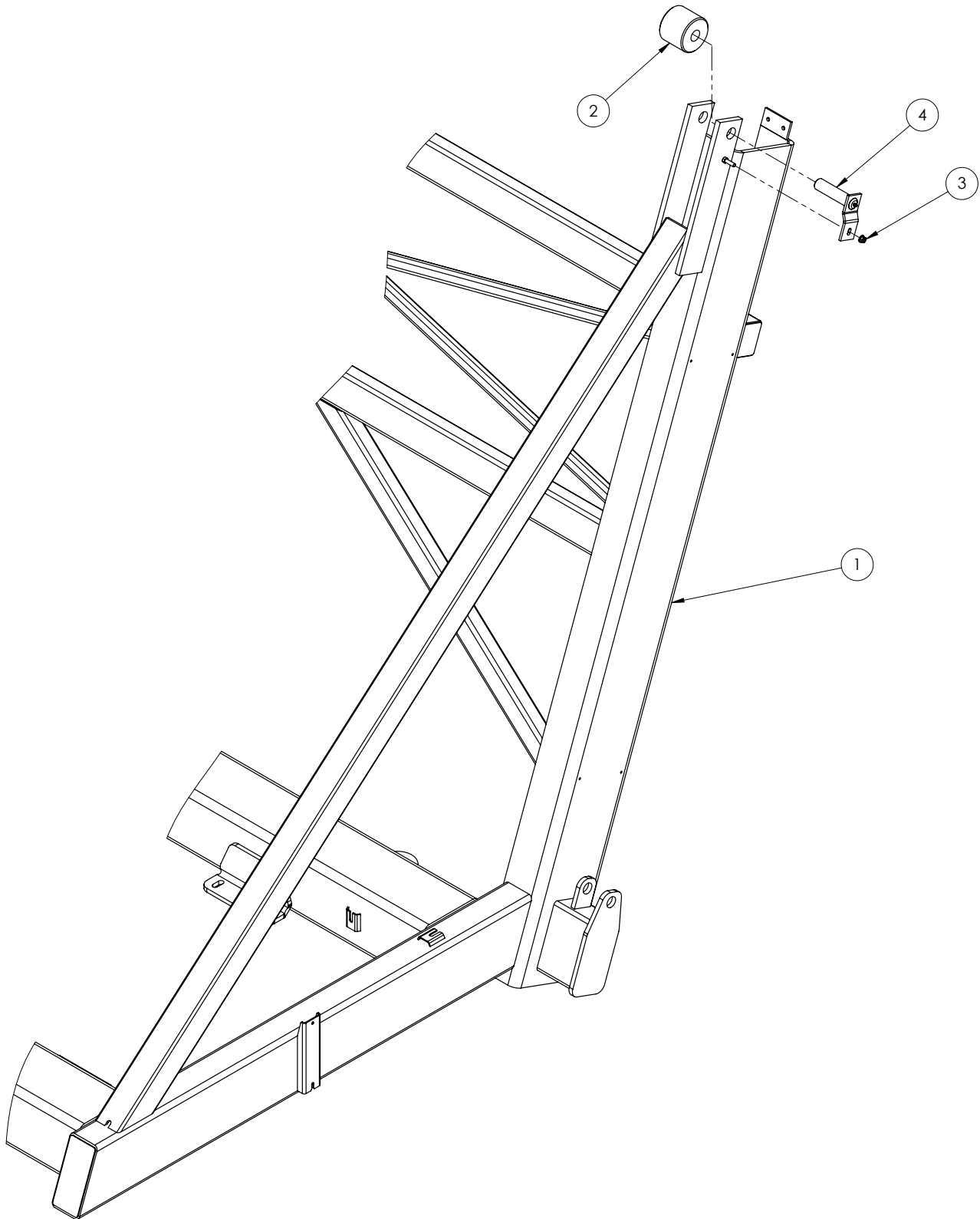

ITEM NO.	PART NUMBER	DESCRIPTION	QTY.
1	617950	FRAME, DUMPBOX 9016	-
2	MP19.00453.7	WHEEL, ROLLER	-
3	600120	NUT, HFH NYLOC 3/8-16	-
4	MP19.00643	PIN, UPPER ROLLER W/ZERKC4	-

ELEVATOR, CYLINDER ASSEMBLY

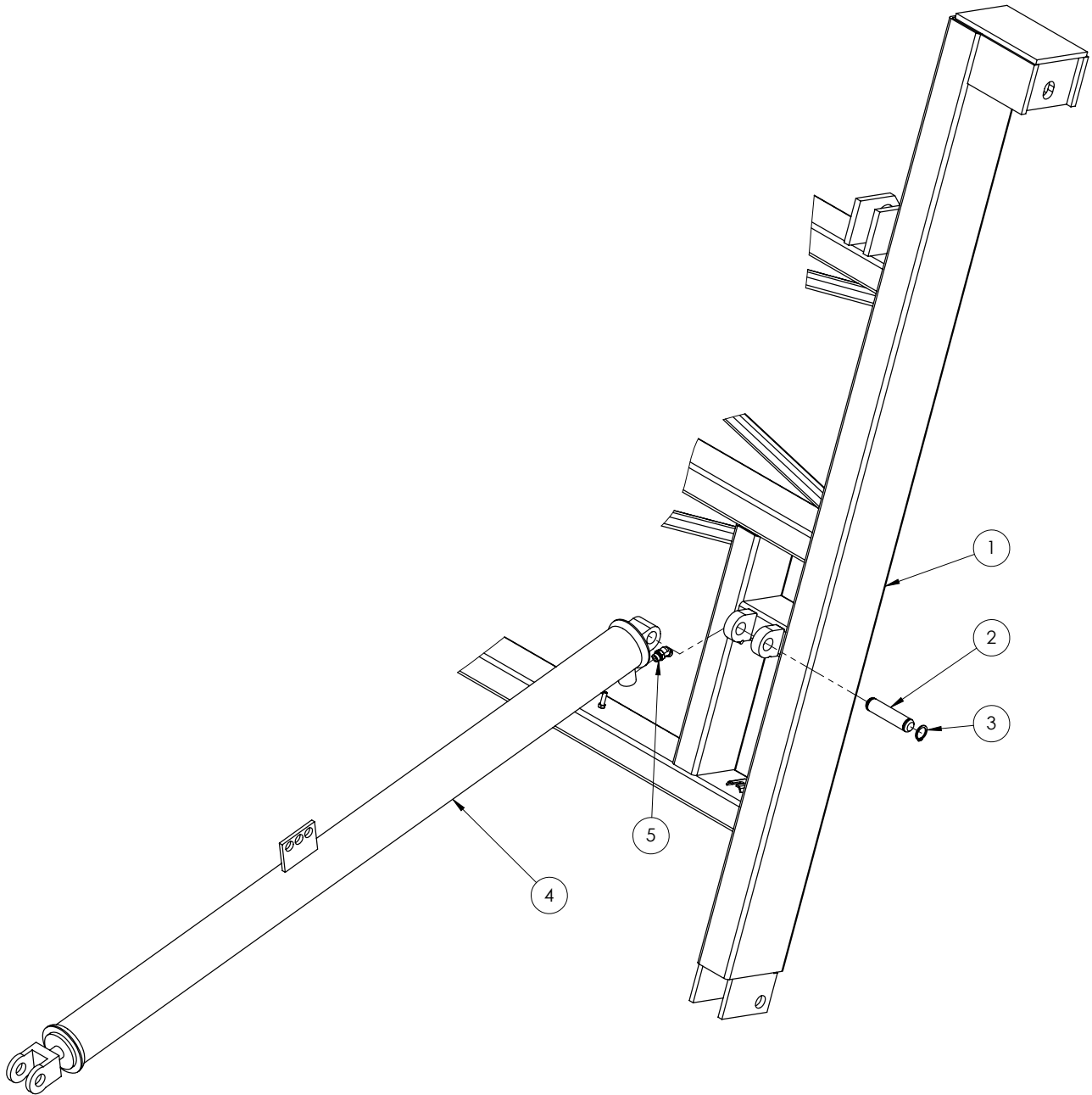

ITEM NO.	PART NUMBER	DESCRIPTION	QTY.
1	MP19.00484.1	ELEVATOR ASSEMBLY	-
2	MP19.01215	PIN - 1.25 X 5.38	-
3	I609053R1	RING, RETAINING 1-1/4	-
4	MP19.01203	CYLINDER, HYD 4 X 68 X 2.50	-
5	MP09.74156	FITTING, HYD 45°	-

FRAME - ELEVATOR, CYLINDER ASSEMBLY

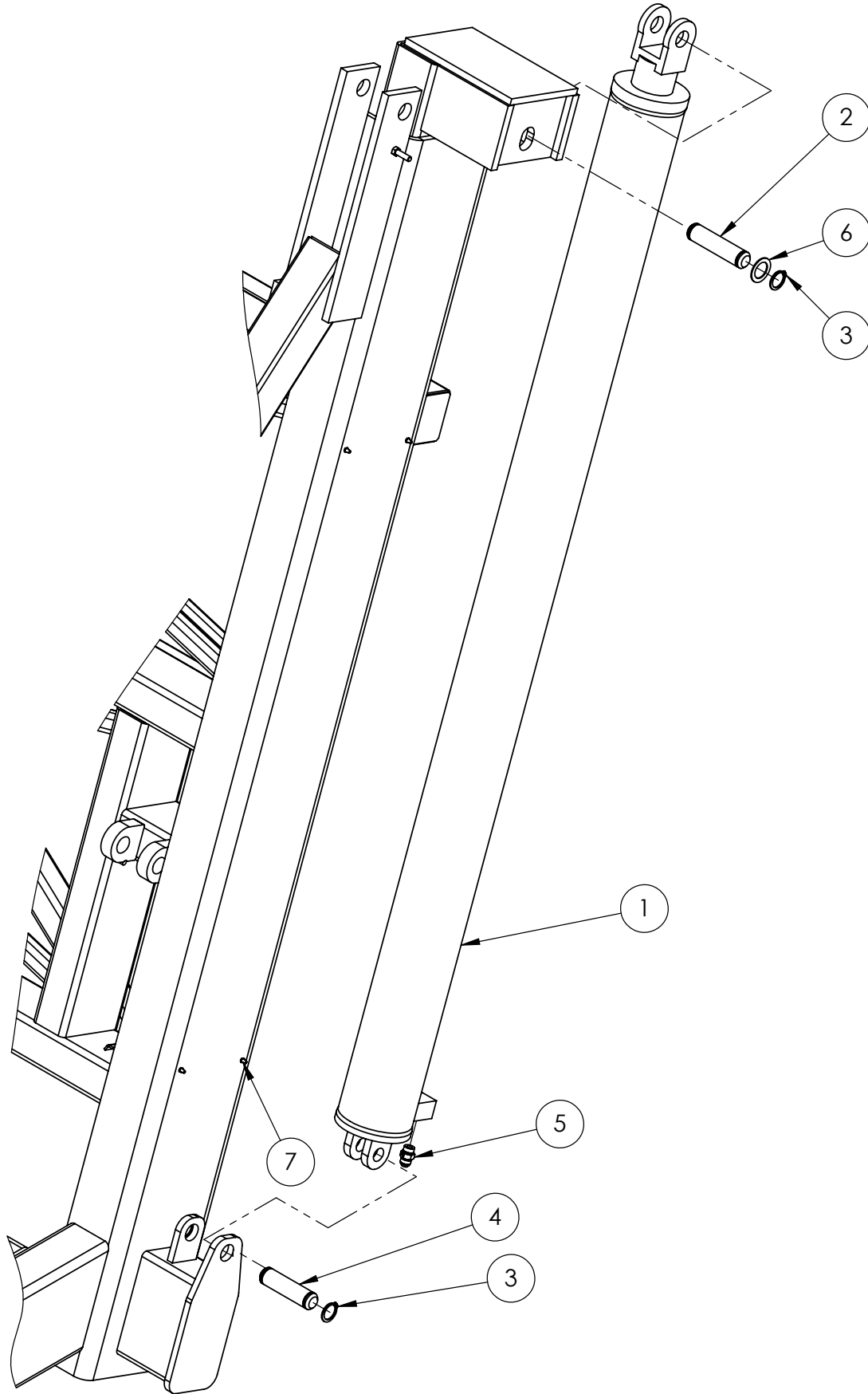

ITEM NO.	PART NUMBER	DESCRIPTION	QTY.
1	618400	CYLINDER, HYD 5 X 74.50 X 3.00	-
2	MP19.01215	PIN - 1.25 X 5.38	-
3	I609053R1	RING, RETAINING 1-1/4	-
4	MP19.00629	PIN, CYLINDER 1.25 X 4.88	-
5	MP09.74155	FITTING, HYD STRAIGHT	-
6	025770	WASHER, MACH 1.25 X 1.87	-
7	115590	FITTING, GREASE	-

FRAME, HYDRAULIC BLOCK ASSEMBLY

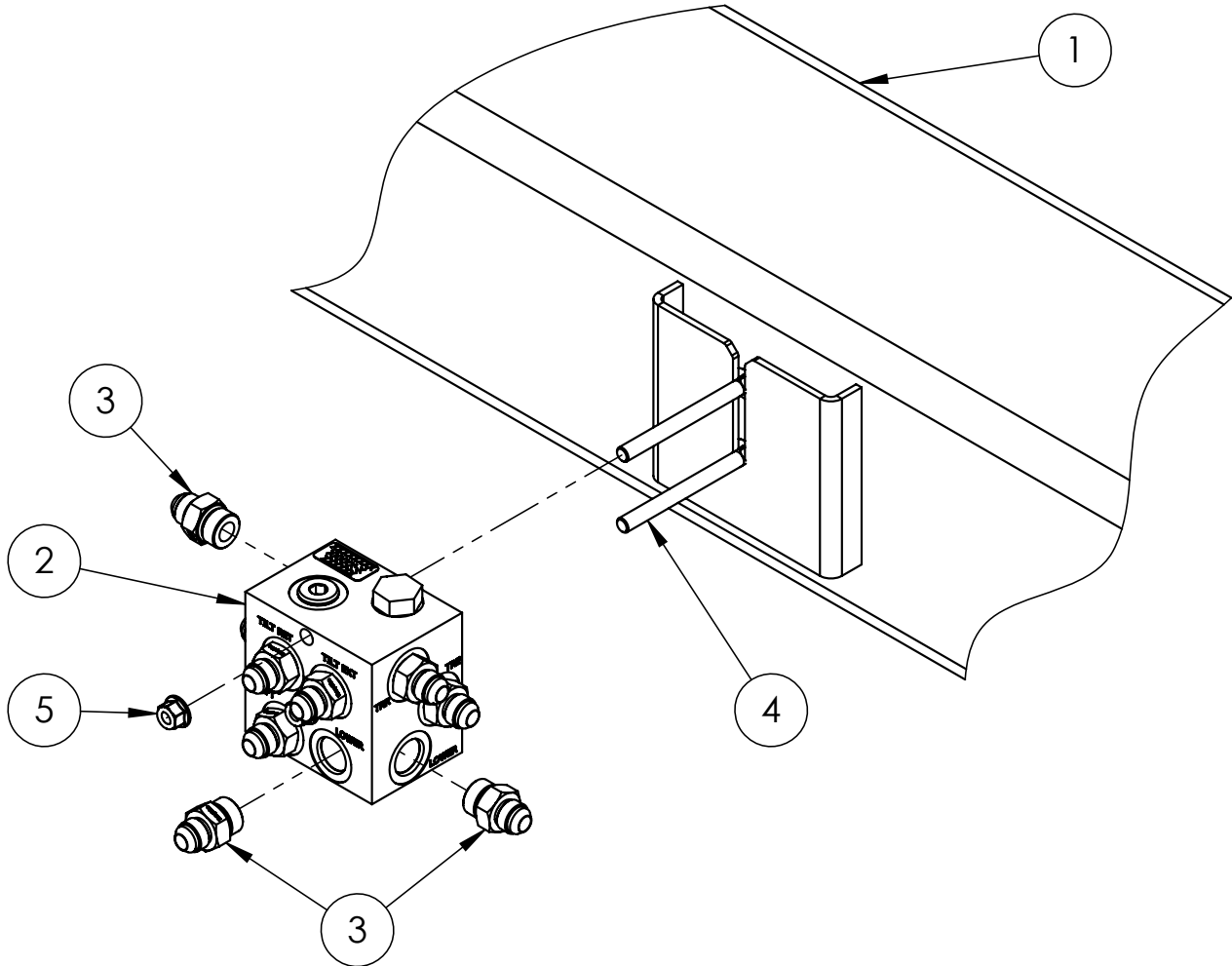

ITEM NO.	PART NUMBER	DESCRIPTION	QTY.
1	617950	FRAME, DUMPBOX 9016	-
2	618430	MANIFOLD, HYD	-
3	MP32.02101	FITTING, HYD STRAIGHT	-
4	991190	BOLT, CRG 3/8-16 X 3-1/2	-
5	600120	NUT, HFH NYLOC 3/8-16	-

TANK, GUARD ASSEMBLY

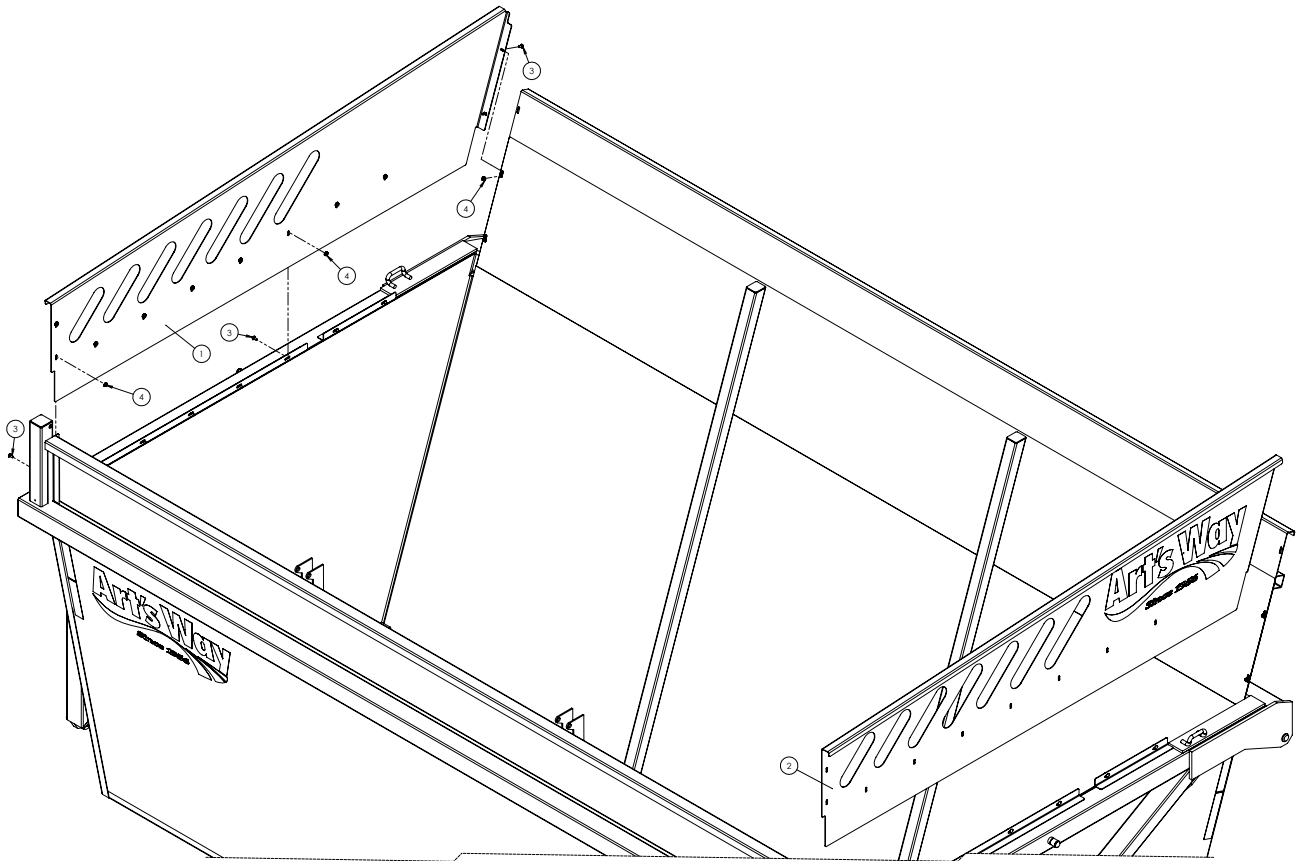

ITEM NO.	PART NUMBER	DESCRIPTION	QTY.
1	618270	PANEL, FRONT LH DUMP	1
2	618260	PANEL, REAR LH DUMP	1
3	012410	BOLT, CRG 5/16-18X3/4 SSN ZN	22
4	600110	NUT, HFH NYLOC 5/16-18	22

NOTES:

NOTES:

Art's

Since

NOTES:





Art's-Way Manufacturing Co., Inc. TECHNICAL MANUALS

Manuals are available from your local dealer or Art's-Way Manufacturing Co., Inc. for the operation, service, and repair of your machine. For prompt convenient service, contact your local dealer for assistance in obtaining the manuals for your machine.

Your local dealer can expedite your order for operator manuals, illustrated parts catalogs, service manuals, and maintenance records.

Always give the Machine Name, Model, and Serial Number so your local dealer can provide the correct manuals for your machine.

Art's-Way Manufacturing Co., Inc. reserves the right to make improvements in design or changes in specifications at any time without incurring any obligation to install them on units previously sold.

Except as expressly authorized, no part of this manual may be reproduced, copied, transmitted, disseminated, downloaded or stored in any storage medium, for any purpose without the express prior written consent of Art's-Way Manufacturing Co., Inc.

ART'S-WAY MANUFACTURING CO., INC.

HWY 9 WEST - PO Box 288

Armstrong, IA. 50514 U.S.A

© Copyright 2012

ART'S-WAY MANUFACTURING CO., INC.

All Rights Reserved