

# MILLER PRO

## HIGH LIFT DUMP BOX

### *PARTS BOOK*

MODELS 9012 & 9015

19.01013B

This parts book is furnished for your convenience only. All parts must be purchased through an authorized dealer. Call us for a dealer near you.



P O Box 127  
511 East Main St.  
St. Nazianz, WI 54232  
(920) 773-2121

Issue Date: 8/04



# MILLER PRO

## 9012 & 9015 High Lift Dump Box

### Contents

	Page
<b>Frame, Latch &amp; Weight Box (4-Wheel Running Gear)</b> .....	<b>2</b>
Frame, Latch & Weight Box (4-Wheel Running Gear) Parts List.....	3
<b>Frame &amp; Latch (2-Wheel Cart)</b> .....	<b>4</b>
Frame & Latch (2-Wheel Cart) Parts List .....	5
<b>Roof</b> .....	<b>6</b>
Roof Parts List .....	7
<b>Running Gear (4-Wheel)</b> .....	<b>8, 10</b>
Running Gear (4-Wheel) Parts List .....	9, 11
<b>Cart (2-Wheel)</b> .....	<b>12</b>
Cart (2-Wheel) Parts List .....	13
<b>6" Riser Kit (4-Wheel Running Gear)</b> .....	<b>14</b>
6" Riser Kit (4-Wheel Running Gear) Parts List .....	15
<b>6" Riser Kit (Cart Style)</b> .....	<b>16</b>
6" Riser Kit (Cart Style) Parts List .....	17
<b>Hydraulic System (4-Wheel Running Gear)</b> .....	<b>18</b>
Hydraulic System (4-Wheel Running Gear) Parts List .....	19
<b>Hydraulic System (2-Wheel Cart)</b> .....	<b>20</b>
Hydraulic System (2-Wheel Cart) Parts List .....	21
<b>Hydraulic Cylinder (Fisher Hydraulics) S/N 19.00580 to 19.00645</b> .....	<b>22</b>
Hydraulic Cylinder (Fisher Hydraulics) S/N 19.00580 to 19.00645 Parts List.....	23
<b>Hydraulic Cylinder (Energy Mfg.) S/N 19.00650 &amp; Up</b> .....	<b>24</b>
Hydraulic Cylinder (Energy Mfg.) S/N 19.00650 & Up Parts List .....	25
<b>Hydraulic Cylinder (Energy Mfg.) Optional Special Large Diameter Cylinders</b> .....	<b>26</b>
Hydraulic Cylinder (Energy Mfg.) Optional Special Large Diameter Cylinders Parts List .....	27
<b>Electrical</b> .....	<b>28</b>
Electrical Parts List .....	29
<b>Brakes</b> .....	<b>30</b>
Brakes Parts List .....	31
<b>Brake Pole</b> .....	<b>32</b>
Brake Pole Parts List.....	33
<b>Tank And Decals</b> .....	<b>34</b>
Tank And Decal Parts List .....	35
<b>Part Number Index</b> .....	<b>36</b>

# Frame, Latch & Weight Box (4-Wheel Running Gear)

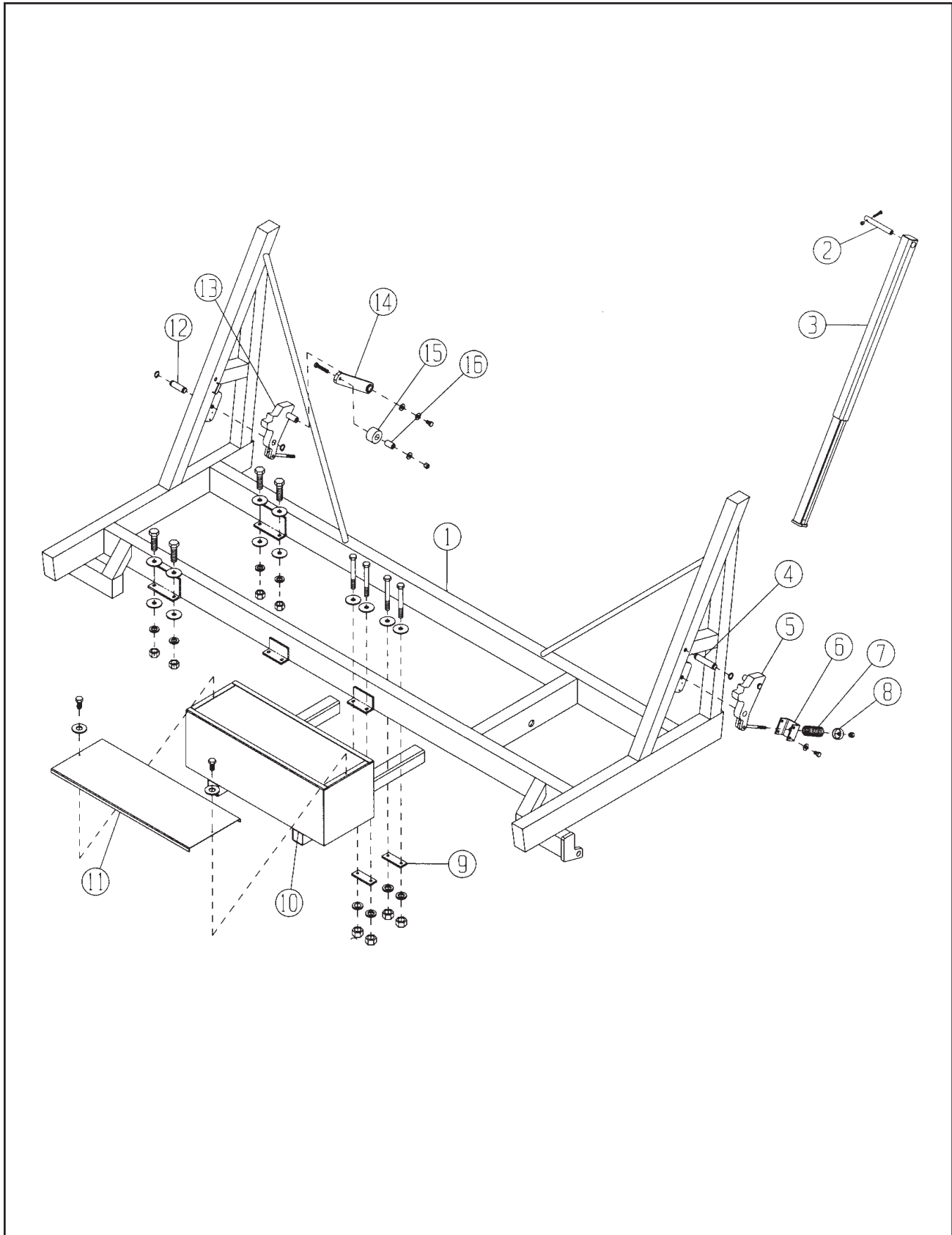

# MILLER PRO

## Frame, Latch & Weight Box (4-Wheel Running Gear) Parts List

Item	Part No.	Quantity	Description
1	19.00843.7	1	Frame (12 Ft)
	19.00844.7	1	Frame (15 Ft)
	903832	8	Bolt, Hex, 5/8-11 x 2-1/2 Gr 5
	900498	16	Flat Washer, 5/8
	900508	8	Lockwasher, 5/8
	900371	8	Nut, Hex, 5/8-11
2	19.00938	2	Pin - Tank Pivot
	906401	2	Nut, Hex, 1/2-13 Nyl Ins
	901341	2	Bolt, Hex, 1/2-13 x 2-1/2 Gr 5
3	19.00930.7	2	Slide Tube Weldment
4	19.00365	2	Slide Tube Cylinder Mounting Pin
	100.11100	4	Retaining Ring, 1, Heavy
5	19.01158.7	1	Latch Weldment, Front (Replaces Part #19.00789.7)
6	19.00985.7	2	Spring Mount
	902364	8	Bolt, Hex, 3/8-16 x 3/4 Gr 5
	900504	8	Lockwasher, 3/8
7	19.00984.7	2	Spring, Compression, 1.937 x .207 x 5.5
8	12.10497.7	2	Guide, Spring
	900497	2	Flat Washer, 1/2
	906401	2	Nut, Hex, 1/2-13 Nyl Ins
9	19.00663.7	4	Strap, Weight Box
	900498	8	Flat Washer, 5/8
	900508	8	Lockwasher, 5/8
	900371	8	Nut, Hex, 5/8-11
	09.73710	8	Bolt, Hex, 5/8-11 x 6-1/2 Gr 5
10	19.00935.7	1	Weight Box (12 Ft)
	19.00664.7	1	Weight Box (15 Ft)
11	19.00937.7	1	Weight Box Cover (12 Ft)
	19.00492.7	1	Weight Box Cover (15 Ft)
	904172	2	Nut, Clip 3/8-16
	902367	2	Bolt, Hex, 3/8-16 x 1-1/4 Gr 5
	900495	2	Flat Washer, 3/8
12	19.00775	2	Pin - Latch Pivot
	100.11100	4	Retaining Ring, 1, Heavy
13	19.01157.7	1	Latch Weldment, Rear (Replaces #19.00788.7)
	900497	2	Flat Washer, 1/2
	900506	2	Lockwasher, 1/2
	902930	2	Bolt, Hex, 1/2-13 x 1 Gr 5
14	19.00779.7	2	Latch Bar Weldment
15	19.00981	2	Roller - 2.5 OD x 1.04 ID x 1.50 UHMW
16	19.00990	2	Spacer, .56 x 1.00 x 1.62
	903853	2	Bolt, Hex, 1/2-13 x 2-3/4 Gr 5
	900497	2	Flat Washer, 1/2
	906401	2	Nut, Hex, 1/2-13 Nyl Ins

## Frame & Latch (2-Wheel Cart)

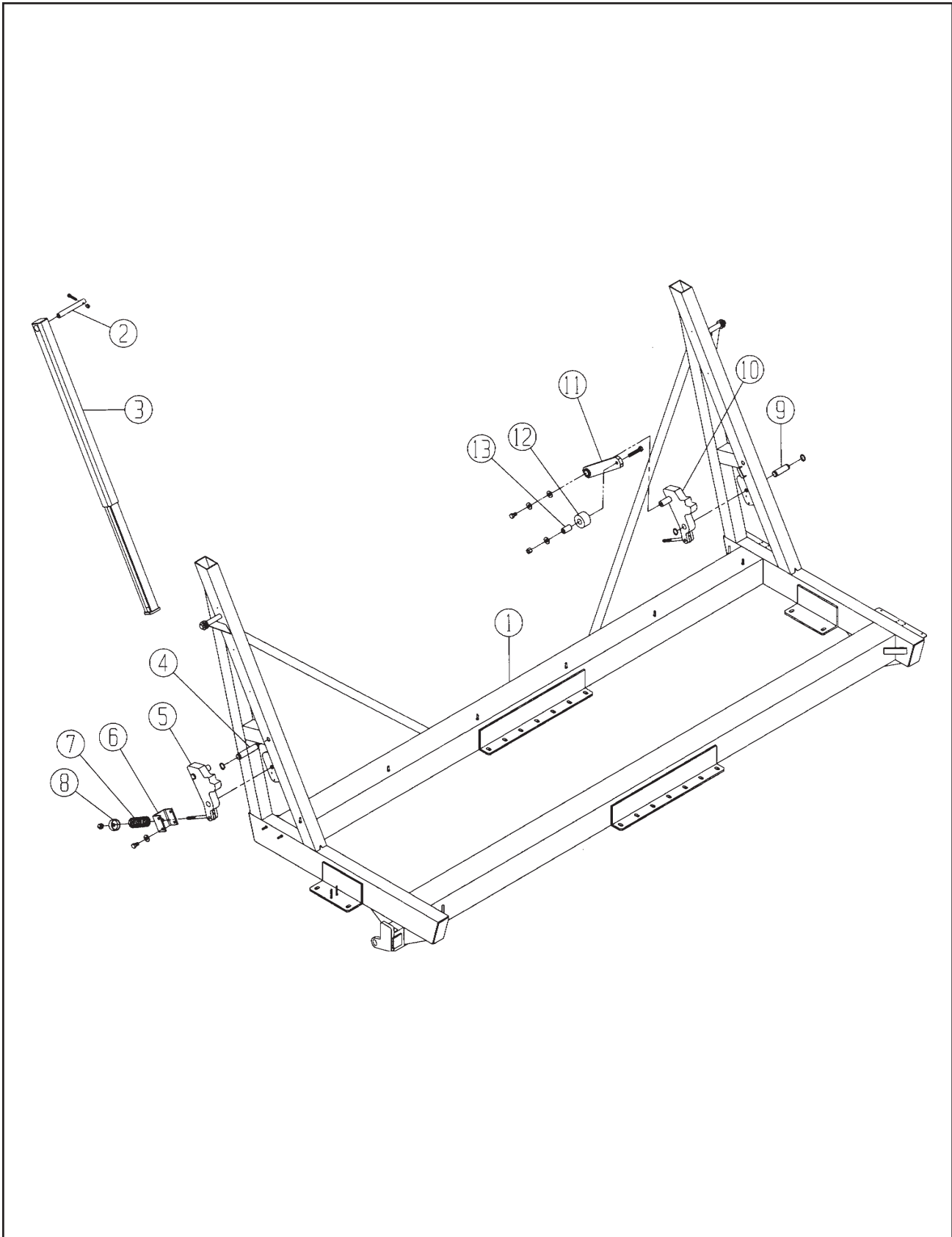

# MILLER PRO

## Frame & Latch (2-Wheel Cart) Parts List

Item	Part No.	Quantity	Description
1	19.01046.7	1	Frame (15 Ft Cart)
2	19.00938	2	Pin - Tank Pivot
	906401	2	Nut, Hex, 1/2-13 Nyl Ins
	901341	2	Bolt, Hex, 1/2-13 x 2-1/2 Gr 5
3	19.00930.7	2	Slide Tube Weldment
4	19.00365	2	Slide Tube, Cylinder Mounting Pin
	100.11100	4	Retaining Ring, 1, Heavy
5	19.01157.7	1	Latch Weldment, Rear
6	19.00985.7	2	Spring Mount
	902364	8	Bolt, Hex, 3/8-16 x 3/4 Gr 5
	900504	8	Lockwasher, 3/8
7	19.00984.7	2	Spring, Compression, 1.937 x .207 x 5.5
8	12.10497.7	2	Guide, Spring
	900497	2	Flat Washer, 1/2
	906401	2	Nut, Hex, 1/2-13 Nyl Ins
9	19.00775	2	Pin - Latch Pivot
	100.11100	4	Retaining Ring, 1, Heavy
10	19.01158.7	1	Latch Weldment, Front
	900497	2	Flat Washer, 1/2
	900506	2	Lockwasher, 1/2
	902930	2	Bolt, Hex, 1/2-13 x 1 Gr 5
11	19.00779.7	2	Latch Bar Weldment
12	19.00981	2	Roller - 2.5 OD x 1.04 ID x 1.50 UHMW
13	19.00990	2	Spacer, .56 x 1.00 x 1.62
	903853	2	Bolt, Hex, 1/2-13 x 2-3/4 Gr 5
	900497	2	Flat Washer, 1/2
	906401	2	Nut, Hex, 1/2-13 Nyl Ins

# Roof

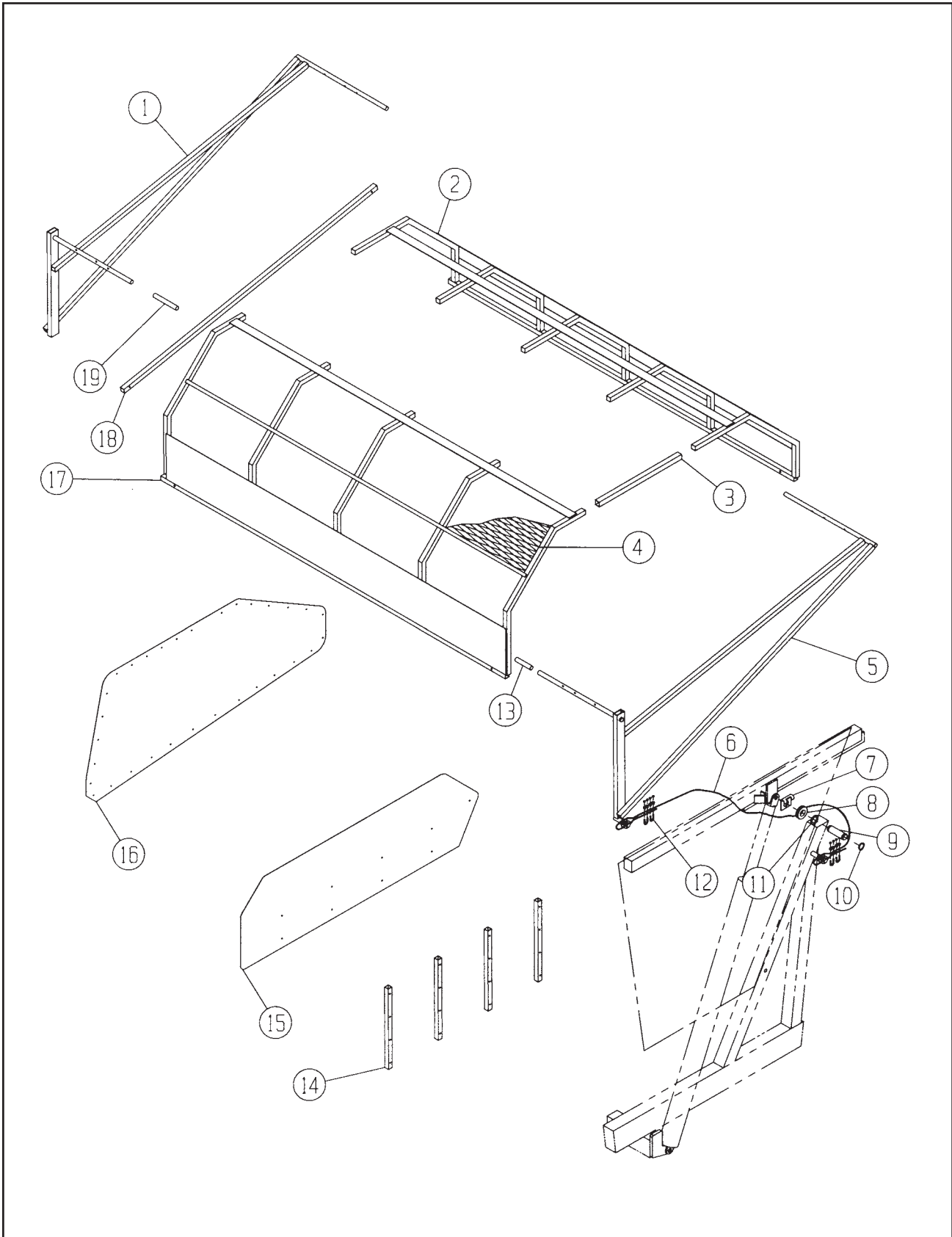



## Roof Parts List

Item	Part No.	Quantity	Description
1	19.00925.7	1	Roof Arm Weldment - Rear
	906401	4	Nut, Hex, 1/2-13 Nylock
	903300	4	Bolt, Hex, 1/2-13 x 2-1/4 Gr 5
2	19.00927.7	1	Tube Weldment - Dump Side (12 Ft)
	19.00929.7	1	Tube Weldment - Dump Side (15 Ft)
3	19.00879.7	5	Tube, Roof Connector (12 Ft)
	19.00879.7	6	Tube, Roof Connector (15 Ft)
	903937	10	Nut, Hex, 3/8-16 Nyl Ins (12 Ft)
	903937	12	Nut, Hex, 3/8-16 Nyl Ins (15 Ft)
	903517	10	Bolt, Hex, 3/8-16 x 2-1/4 Gr 5 (12 Ft)
	903517	12	Bolt, Hex, 3/8-16 x 2-1/4 Gr 5 (15 Ft)
4	19.00893.7	4	Sheet, Expanded Metal (12 Ft)
	19.00893.7	5	Sheet, Expanded Metal (15 Ft)
	907120	113	Screw, Tek, #12-16 x 7/8 (12 Ft)
	907120	134	Screw, Tek, #12-16 x 7/8 (15 Ft)
	09.70891	113	Flat Washer, 1/4 x 1 x 18 Ga (12 Ft)
	09.70891	134	Flat Washer, 1/4 x 1 x 18 Ga (15 Ft)
5	19.00924.7	1	Roof Arm Weldment - Front
	906401	4	Nut, Hex, 1/2-13 Nylock
	903300	4	Bolt, Hex, 1/2-13 x 2-1/4 Gr 5
6	19.00970	2	Cable, 1/4 x 14'
7	19.00040.5	2	Guide, Cable
8	19.00039	2	Pulley
9	19.00958	2	Pin, 1.25 x 4.25, Cyl (S/N 19.00645 & Down)
	19.01161	2	Pin, 1.25 x 5.75, Cyl with Hole (S/N 19.00646 & Up)
	901341	2	Bolt, Hex, 1/2-13 x 1-1/2
	906401	2	Nut, Hex, 1/2-13 Nylock
10	19.00023	4	Retaining Ring, 1.25, Heavy
11	900842	2	Machine Bushing, 1-1/4
12	900143	8	Clamp, Cable, 1/4
13	19.00966.7	1	Spacer, Roof Arm, 6.44" (12 Ft)
	19.00905.7	1	Spacer, Roof Arm, 8.44" (15 Ft)
14	19.00980.7	4	Channel, Crop Guide
	902063	12	Bolt, Hex, 5/16-18 x 2 Gr 5
	906483	13	Nut, Hex, 5/16-18 Nyl Ins
	900494	26	Flat Washer, 5/16
	902859	1	Bolt, Hex, 5/16-18 x 1 Gr 5
15	19.00799.7	1	Panel, Crop Guide (Optional)
16	19.00877.7	1	Roof End Sheet
	907120	25	Screw, Tek, #12-16 x 7/8
	09.70891	25	Flat Washer, 1/4 x 1 x 18 Ga
17	19.00926.7	1	Tube Weldment - Non-Dump Side (12 Ft)
	19.00928.7	1	Tube Weldment - Non-Dump Side (15 Ft)
18	19.00892.7	1	Roof Cross Tube
19	19.00880.7	1	Spacer, Roof Arm, 3.44"

# Running Gear (4-Wheel)

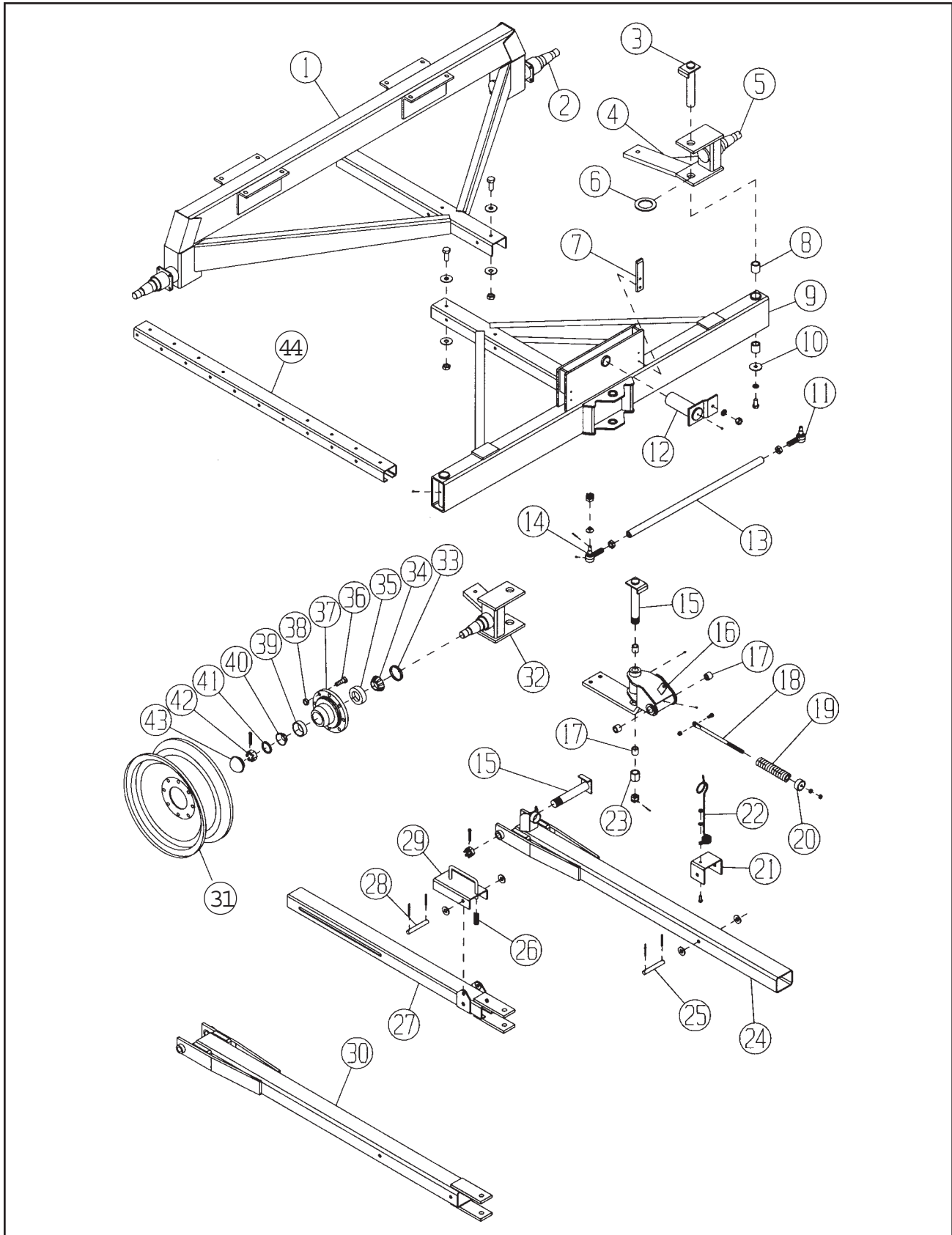

## Running Gear (4-Wheel) Parts List

Item	Part No.	Quantity	Description
1	19.00860.7	1	Rear Axle Weldment, 96" Wheel Base
	19.00861.7	1	Rear Axle Weldment, 120" Wheel Base
	904253	4	Bolt, Hex, 5/8-11 x 2 Gr 5
	09.70954	8	Flat Washer, 5/8 HT
	906402	4	Nut, Hex, 5/8-11 Nyl Ins
2	19.00066	2	Spindle, 3 x 20.12
3	19.00665.7	2	King Pin Weldment
4	19.00915.7	1	Trunnion Weldment, LH, 96" Wheel Base
	19.00917.7	1	Trunnion Weldment, LH, 120" Wheel Base
5	19.00068	2	Spindle, 3 x 11.25
6	19.00480	2	Flat Washer, 3.12 x 4.75 x .25
7	19.00669	4	Wear Pad, Bolster
	09.71123	8	Screw, Cap, 5/16-18 x 1 BTN
8	19.00080	4	Bushing, 1-3/4 x 2-1/8 x 2
9	19.00919.7	1	Front Bolster Weldment, 96" Wheel Base
	19.00920.7	1	Front Bolster Weldment, 120" Wheel Base
	904253	4	Bolt, Hex, 5/8-11 x 2 Gr 5
	09.70954	8	Flat Washer, 5/8 HT
	906402	4	Nut, Hex, 5/8-11 Nyl Ins
10	902374	2	Fitting, Grease, 1/4-28, 45°
	22.37147	2	Flat Washer, .78 x 2.75 x .18
	900700	2	Lockwasher, 3/4
	904777	2	Bolt, Hex, 3/4-10 x 1-1/2 Gr 5
11	12.10303	2	Ball Joint Kit, LH (Includes Ball Joint, Boot, Nut, Pin & Fitting)
	12.10374	2	Nut, Jam, 1-16 LH
12	19.00642	1	Bolster Pin Weldment
	900538	1	Fitting, Grease, 1/4-28
	900497	1	Flat Washer, 1/2
	900506	1	Lockwasher, 1/2
	900369	1	Nut, Hex, 1/2-13
13	19.00868.7	2	Tie Rod, 96" Wheel Base
	19.00869.7	2	Tie Rod, 120" Wheel Base
14	12.10304	2	Ball Joint Kit, RH (Includes Ball Joint, Boot, Nut, Pin & Fitting)
	12.10375	2	Nut, Jam, 1-16
15	12.10606.7	2	Hitch Pin Weldment, 1-1/4 x 12-5/8
	904866	2	Nut, Hex Castle, 1-1/4-7
	09.73906	2	Pin, Cotter, 5/16 x 2-1/2
16	12.10665.7	1	Hitch Box Weldment
	900538	2	Fitting, Grease, 1/4-28
17	16.10645	4	Bushing, 1-1/4 x 1-1/2 x 2
18	12.10495	1	Bolt, 3/4 spade
	900372	2	Nut, Hex, 3/4-10
	900414	1	Bolt, Hex, 1/2-13 x 2 Gr 5
	906401	1	Nut, hex, 1/2-13 Nylock
19	12.10056	1	Spring, Compression
20	12.10497.7	1	Guide, Spring

# Running Gear (4-Wheel) continued

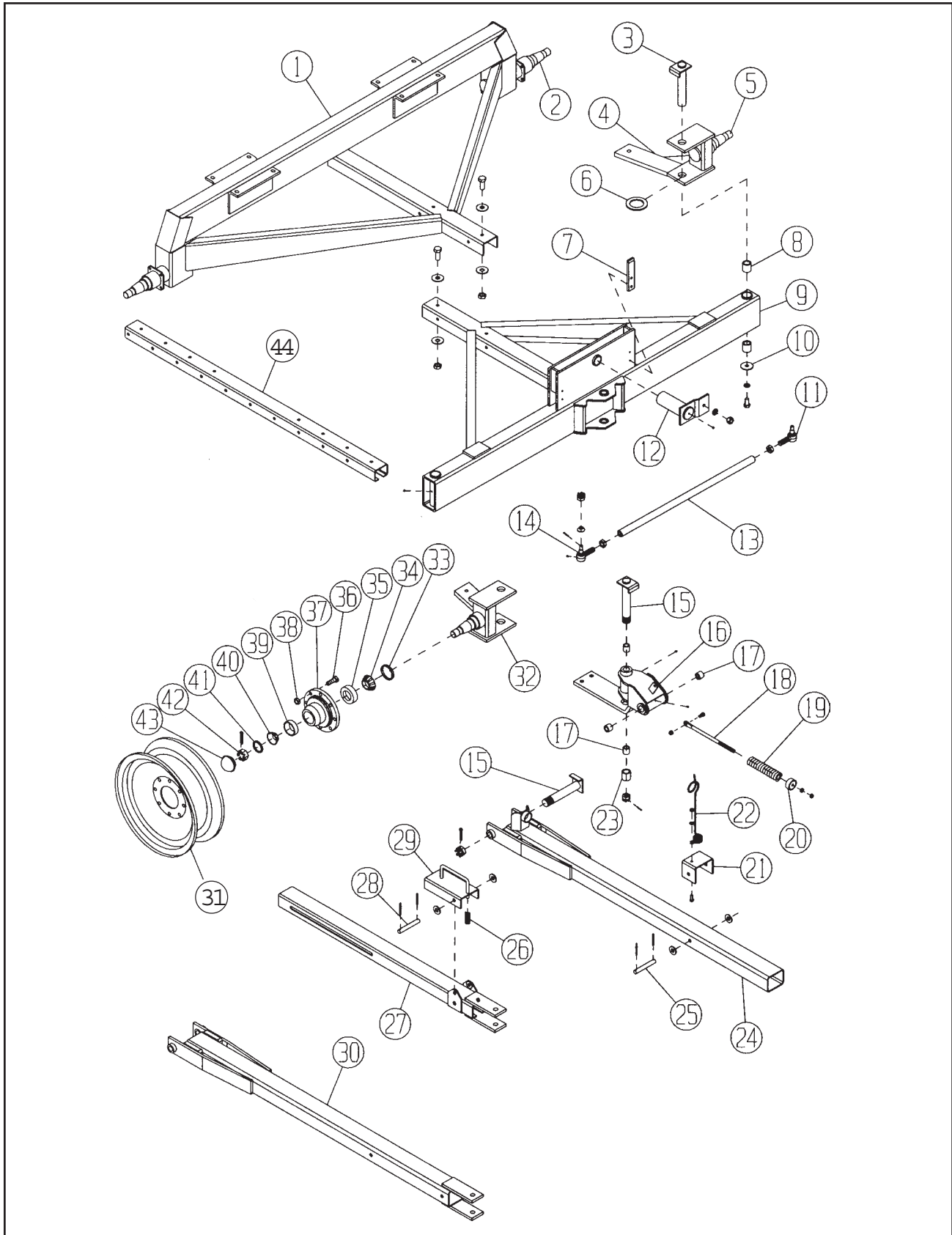

# MILLER PRO

## Running Gear (4-Wheel) Parts List continued

Item	Part No.	Quantity	Description
21	19.00713.7	1	Bracket, Hose Hanger
	902915	1	Flat Washer, 7/16
	09.70731	1	Nut, Hex, 7/16-14 Nyl Ins
	904871	1	Bolt, Hex, 7/16-14 x 1-1/4 Gr 5
22	07.06420.7	1	Bracket, Hose
23	12.10337.7	1	Spacer, Hitch Box
24	12.10598.7	1	Pole, Long
25	12.10388	1	Pin, 3/4 x 7
	09.72003	2	Pin, Roll, 3/16 x 2
	900499	2	Flat Washer, 3/4
26	12.10490	1	Spring, Compression
27	12.10603.7	1	Pole Extension
28	12.10388	1	Pin, 3/4 x 7
	09.72003	2	Pin, Roll, 3/16 x 2
	900499	2	Flat Washer, 3/4
29	12.10360.7	1	Adjuster
30	19.00784.7	1	Pole Weldment
31	19.00152	2	Wheel, 20 x W8B, 8 Bolt (Dump Side, Double Center)
	19.00156	2	Decal, Dump Side
	19.00304	2	Wheel, 20 x W8B, 8 Bolt (Non Dump Side, Single Center)
	19.818724	4	11.00 x 20 Used Military Tire
	19.00295	4	Inner Tube
	12.10506	4	Wheel, 22.5 x 13, 8 Bolt
	12.09999	4	Tire, 16.5L x 22.5 Used Truck
32	19.00916.7	1	Trunnion Weldment, RH, 96" Wheel Base
	19.00918.7	1	Trunnion Weldment, RH, 120" Wheel Base
33	19.00082	4	Seal, Oil, 3
34	19.00083	4	Bearing Cone, 2.250
35	19.00084	4	Bearing Cup, 2.250
36	19.00085	32	Stud, Wheel, 5/8-18 x 2-3/8
37	19.00081	4	Hub Assembly w/Cups & Studs (Includes Items 35, 36 & 39)
38	65.10125	32	Nut, Wheel, 5/8-18
39	65.10110	4	Bearing Cup, 1.625
40	65.10108	4	Bearing Cone, 1.625
41	65.10106	4	Flat Washer, 1.06 x 2.13 x .25
42	65.10104	4	Nut, Hex Slotted, 1-14 UNS
	901658	4	Pin, Cotter, 7/32 x 2-1/4
43	903205	4	Cap, Hub
44	12.10050.7	1	Reach - Short
			<b>Optional Wheels</b>
	12.00114	4	Wheel, 16.1 x 14 (Not Shown)
	19.00400	32	Nut, Wheel, Flanged (Not Shown)
	12.10506	4	Wheel, 22.5 x 13 (Not Shown)
	19.00400	32	Nut, Wheel, Flanged (Not Shown)

# Cart (2-Wheel)

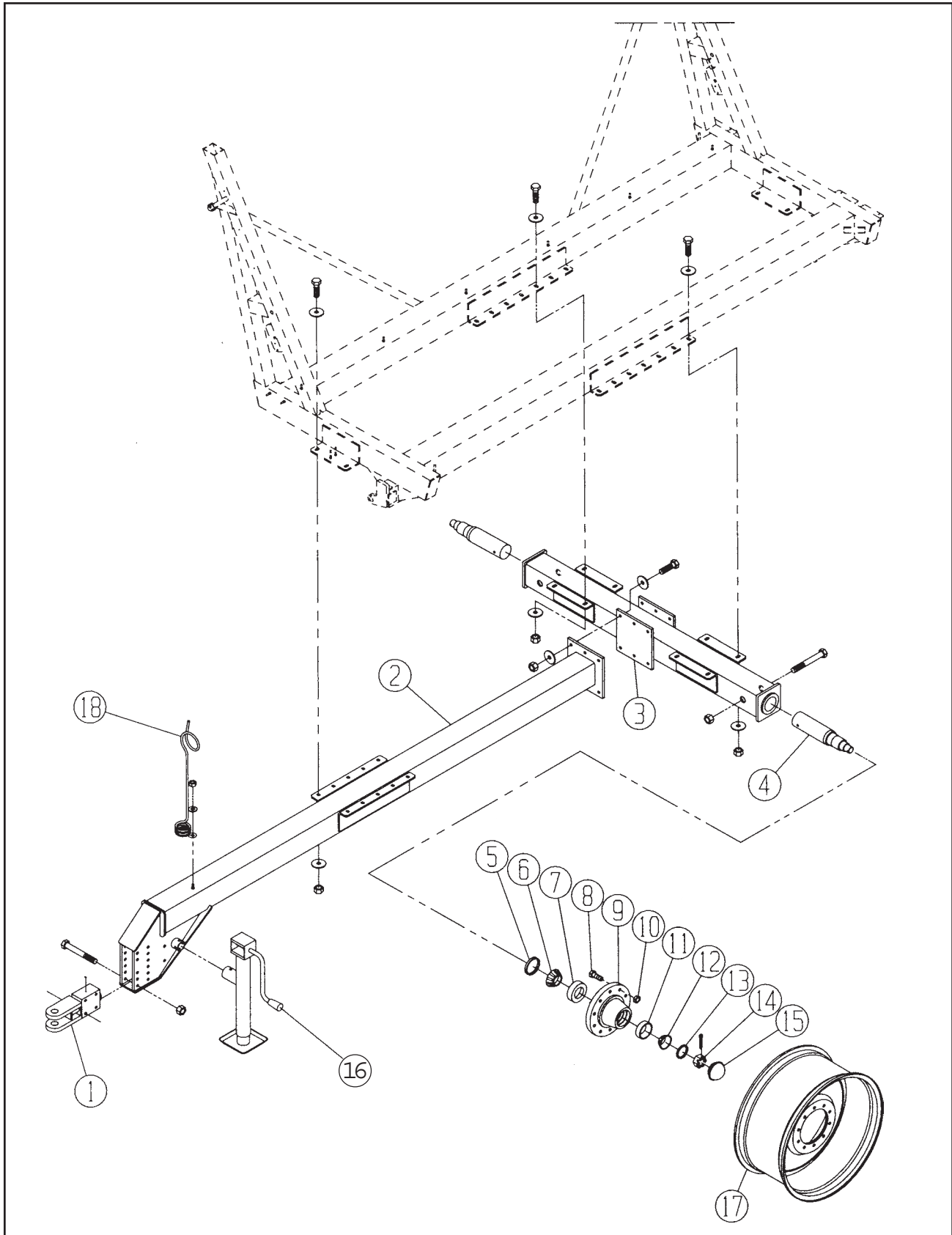

# MILLER PRO

## Cart (2-Wheel) Parts List

Item	Part No.	Quantity	Description
1	19.01057.7	1	Tongue Weldment - 15 Ft Cart
	907078	4	Bolt, Hex, 3/4-10 x 7-1/2 Gr 5
	906349	4	Nut, Hex Lock, 3/4-10 Nyl Ins
	903993	1	Fitting, Grease, 1/4-28, 90°
2	19.01024.7	1	Hitch Weldment - 15 Ft Cart
	903423	4	Bolt, Hex, 3/4-10 x 2-1/2 Gr 5
	900499	8	Flat Washer, 3/4
	906349	4	Nut, Hex Lock, 3/4-10 Nyl Ins
3	19.01039.7	1	Axle Weldment - 15 Ft Cart
	903423	8	Bolt, Hex, 3/4-10 x 2-1/2 Gr 5
	900499	16	Flat Washer, 3/4
	906349	8	Nut, Hex Lock, 3/4-10 Nyl Ins
	09.71756	6	Bolt, Hex, 3/4-10 x 3 Gr 5
	900499	12	Flat Washer, 3/4
4	19.01002	2	Spindle - 4.5 OD x 21.25
	907137	2	Bolt, Hex, 5/8-11 x 7-1/2 Gr 5
	906402	2	Nut, Hex Lock, 5/8-11 Nyl Ins
5	19.01121	2	Seal, Oil, 4.375
6	19.01122	2	Bearing Cone, 3.54
7	19.01123	2	Bearing Cup, 3.54
8	19.01124	20	Stud, Wheel, 3/4-16 x 2-13/16
9	19.01125	2	Hub Assembly w/Cups & Studs (Includes Items 7, 8 & 11)
10	19.01126	20	Nut, Wheel, 3/4-16 Flange
11	19.01128	2	Bearing Cup, 2.62
12	19.01127	2	Bearing Cone, 2.62
13	19.01129	2	Flat Washer, 2.06 x 4.00 x .25
14	19.01130	2	Nut, Hex Slotted, 2-12 UNS
	19.01131	2	Pin, Cotter, 5/16 x 3-1/2
15	19.01132	2	Cap, Hub
16	24.90180	1	Jack, 7000 lb
17	19.01004	2	Wheel, 38 x 18, 10 Bolt, Cart
18	07.06420.7	1	Bracket, Hose
	906400	1	Nut, Hex Lock, 3/8-16 Nyl Ins
	900495	2	Flat Washer, 3/8

# 6" Riser Kit (4-Wheel Running Gear)

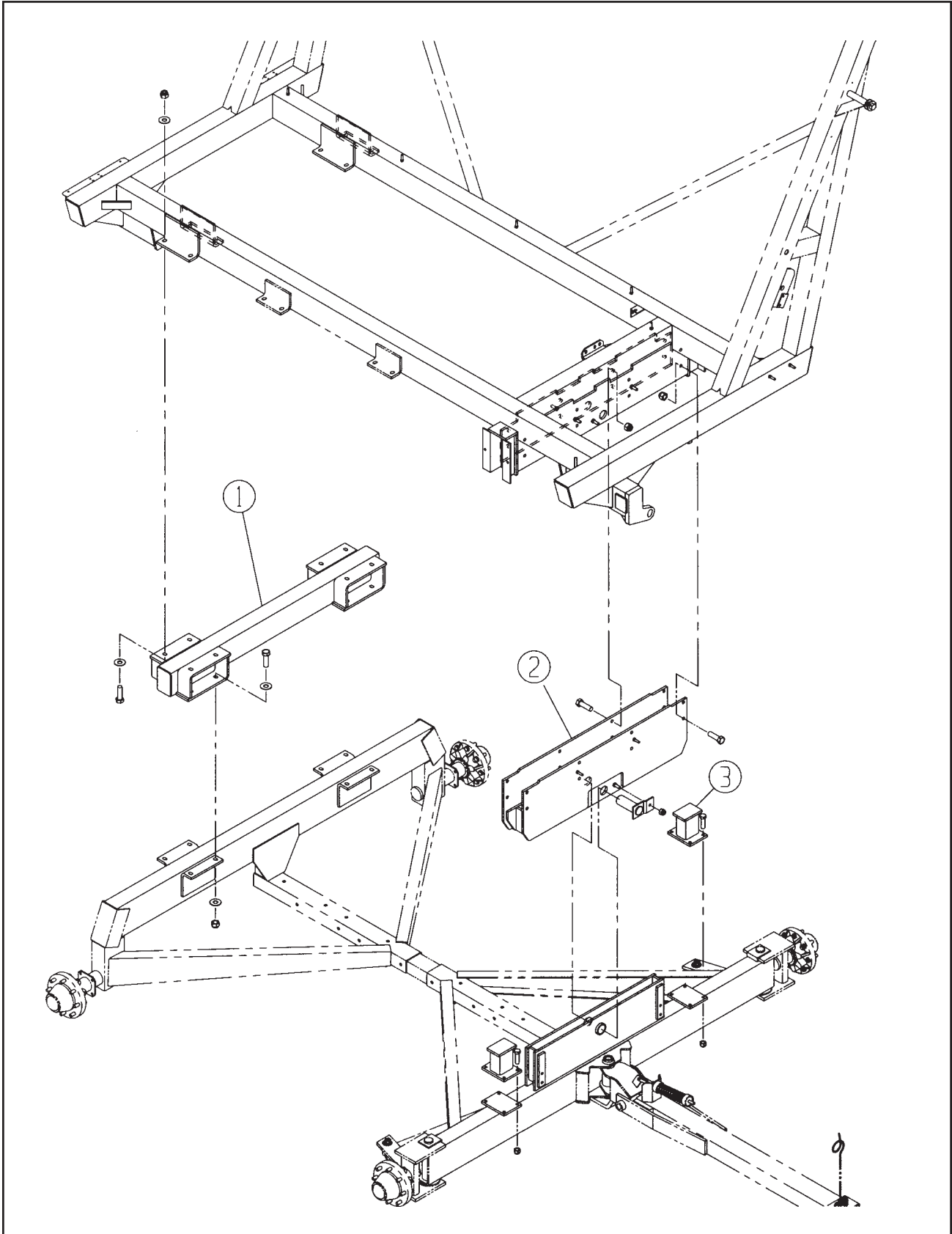





# 6" Riser Kit (Cart Style)

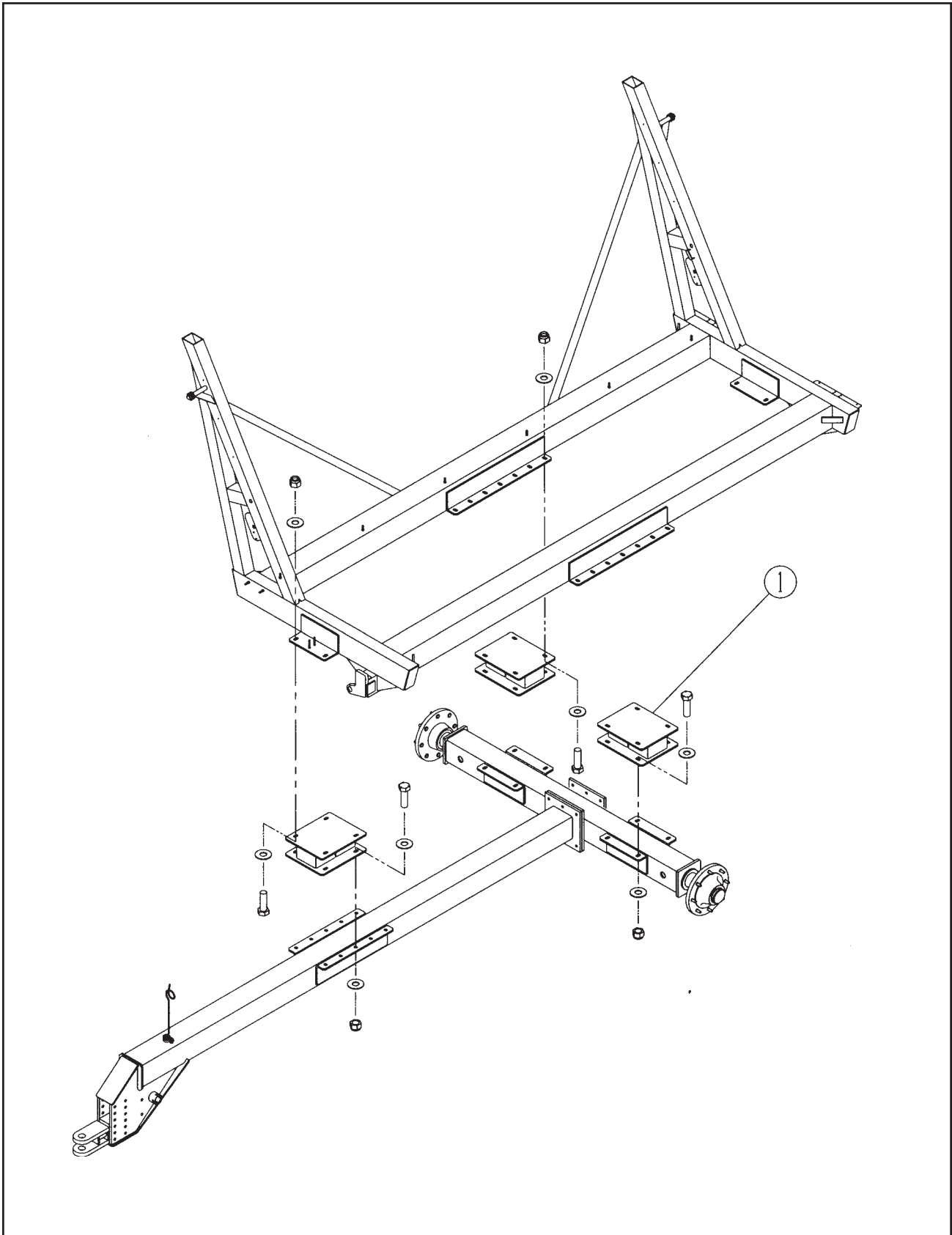



# Hydraulic System (4-Wheel Running Gear)

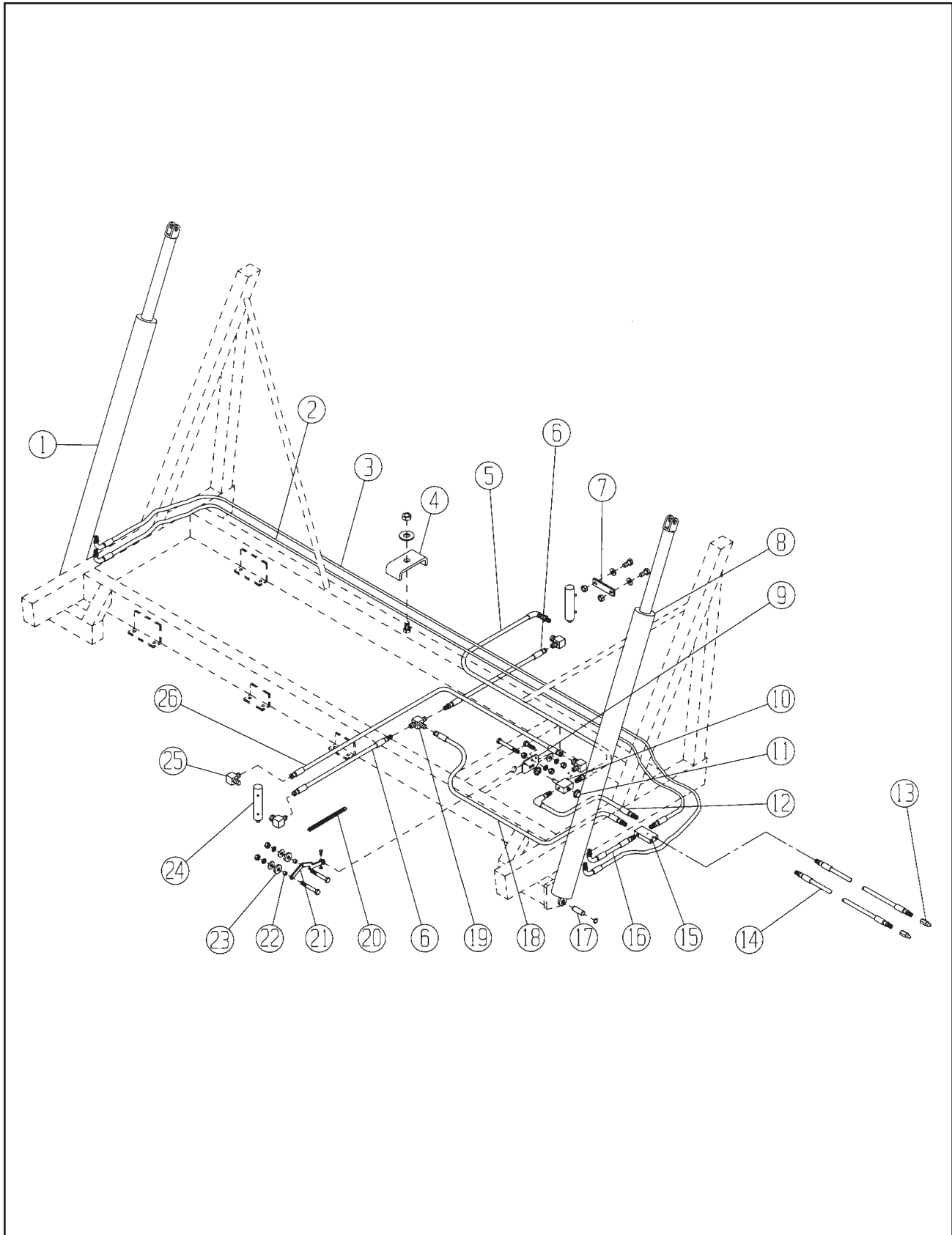

# MILLER PRO

## Hydraulic System (4-Wheel Running Gear) Parts List

Item	Part No.	Quantity	Description
1	19.00863.7	1	Cylinder, 5.0 x 80.5 x 3
2	19.00154	1	Hose Assembly, 210" (12 Ft)
	19.00157	1	Hose Assembly, 250" (15 Ft)
3	19.00045	1	Hose Assembly, 245" (12 Ft)
	19.00153	1	Hose Assembly, 284" (15 Ft)
4	322848B1.7	10	Clip, Hydraulic Line
	901105	10	Flat Washer, 3/8
	902291	10	Nut, Hex Lock, 3/8-16 Nyl Ins
5	19.800206	1	Hose Assembly, 37"
6	19.00998	2	Hose Assembly, 36"
7	19.00520.7	2	Strap, Stabilizer
	902928	4	Bolt, Hex, 1/2-13 x 1-1/4 Gr 5
	900506	4	Lockwasher, 1/2
	900369	4	Nut, Hex, 1/2-13
8	19.00898.7	1	Cylinder, 4.0 x 80.5 x 2.5
9	19.00716.7	1	Plate, Valve
	902928	2	Bolt, Hex, 1/2-13 x 1-1/4 Gr 5
	901937	2	Flat Washer, 1/2
	900506	2	Lockwasher, 1/2
	900369	2	Nut, Hex, 1/2-13
	902675	1	Bolt, Hex, 1/2-13 x 3 Gr 5
	903772	2	Nut, Hex, 1/2-13 Whiz
10	19.00997	1	Stabilizer Valve Assembly
11	19.00684	2	Bushing, Valve
12	19.01000	1	Hose Assembly, 64"
13	07.19044	2	Male Pioneer, 1/2" Coupler
14	19.00571	2	Hose Assembly, 120"
15	19.00995	1	Hydraulic Manifold, SAE Ports
16	19.00155	1	Hose Assembly, 19"
17	19.00630	2	Cylinder Mount Pin, 1.25 x 3.50 (S/N 19.00645 & Down)
	19.01160	2	Cylinder Mount Pin, 1.25 x 4.00 (S/N 19.00650 & Up)
	19.00023	4	Retaining Ring, 1-1/4 Ext, Heavy
18	19.00999	1	Hose Assembly, 24"
19	09.74123	1	Fitting, Tee, 37° Flare, 3/4-16
20	19.00149	1	Spring, Extension, 1.125 x .12 x 12
21	19.00251.7	1	Arm Weldment
	902603	1	Bolt, Hex, 5/16-18 x 2 Gr 5
	906483	1	Nut, Hex Lock, 5/16-18 Nyl Ins
22	19.00278	2	Spacer, .56 x 1.00 x .62
23	19.00151	2	Roller, UHMW
	902050	2	Bolt, Hex, 1/2-13 x 2 Gr 5
	900497	2	Flat Washer, 1/2
	900506	2	Lockwasher, 1/2
	900369	2	Nut, Hex, 1/2-13
24	19.01165.7	2	Cylinder, 3 x 6 x 1.5
25	07.17946	3	Fitting, 90° Elbow, 37° Flare - Orb
26	19.00569	1	Hose Assembly, 57"

# Hydraulic System (2-Wheel Cart)

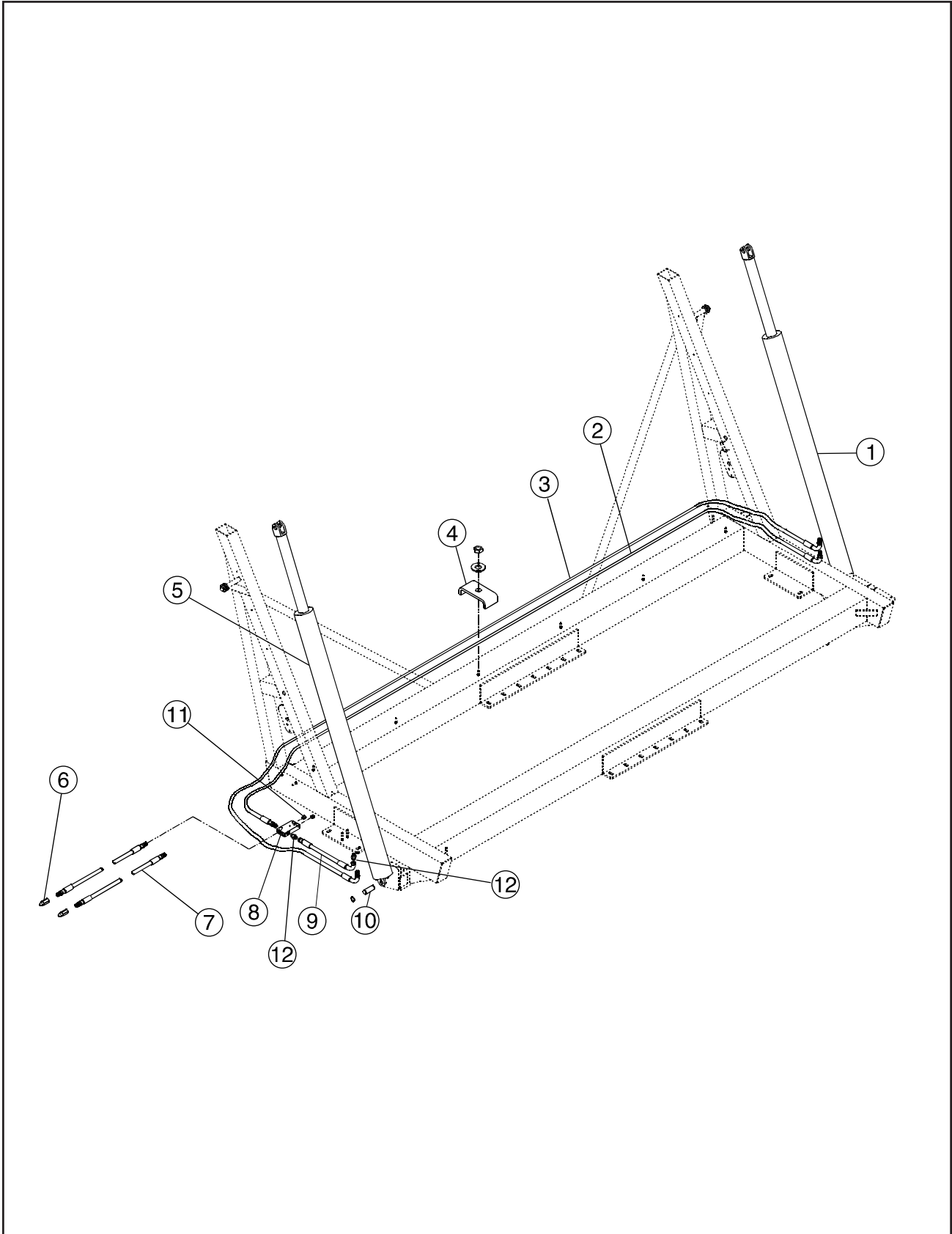



# Hydraulic Cylinder (Fisher Hydraulics) S/N 19.00580 to 19.00645

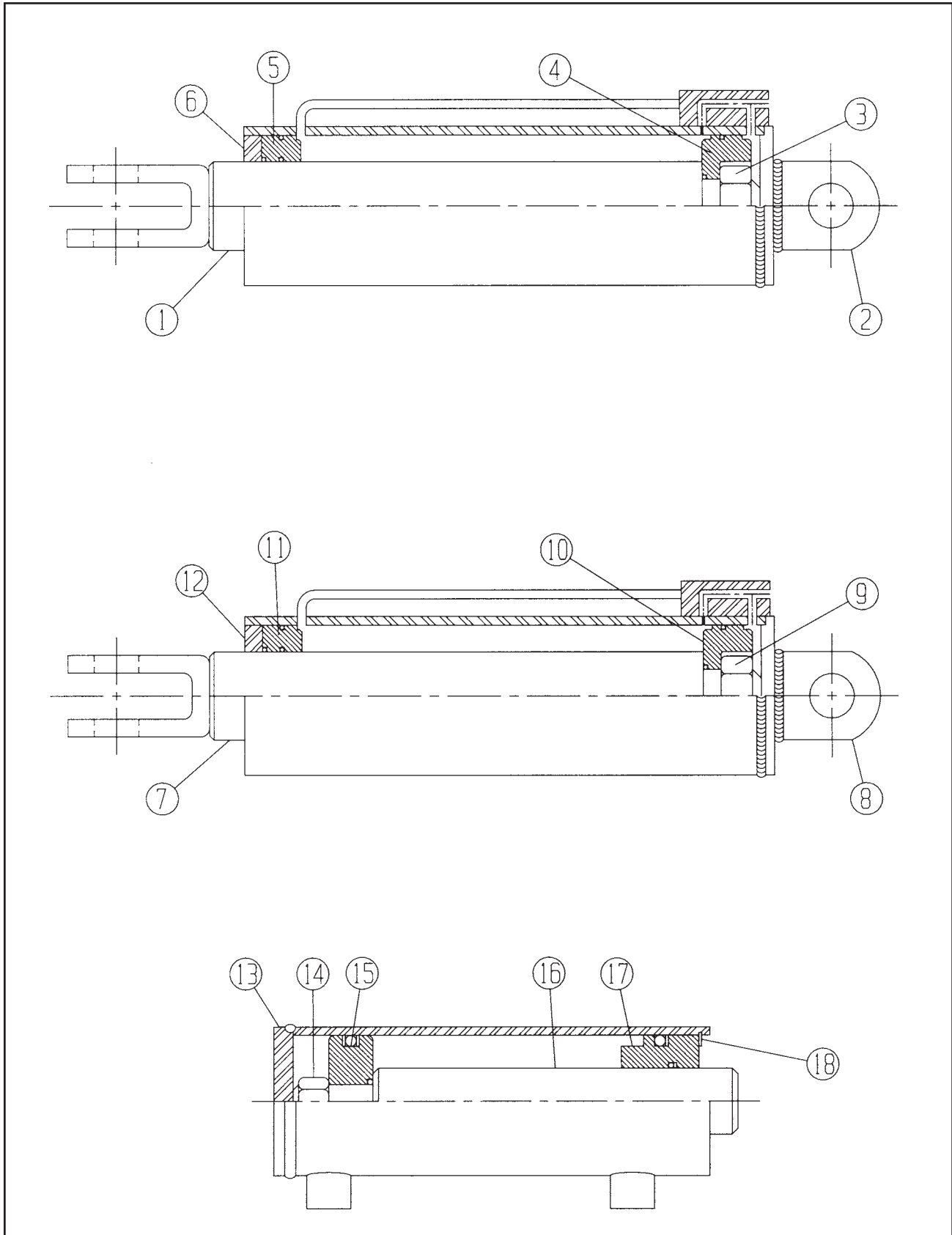



# MILLER PRO

## Hydraulic Cylinder (Fisher Hydraulics) S/N 19.00580 to 19.00645 Parts List

Item	Part No.	Quantity	Description
			4" HYDRAULIC CYLINDER FISHER HYDRAULICS 19.00898 (Replaced by 19.01164.7 & 19.01172)
			<b>Identification Feature - Cylinder Assembly Has A Locking Ring With External Threads On The Rod End.</b>
1	19.01009	1	Piston Rod, 4 x 80.5 x 2.50 Cyl
2	NSS	1	Butt & Tube Assembly, 4 x 80.5 x 2.5 Cyl
3	19.00124	1	Nut
4	19.00125	1	Piston
5	19.00126	1	Gland
6	19.00127	1	Locking Ring, External Thread
	19.00056	1	Seal Kit
			5" HYDRAULIC CYLINDER FISHER HYDRAULICS 19.00863 (Replaced by 19.01163.7 & 19.01172)
			<b>Identification Feature - Cylinder Assembly Has A Locking Ring With External Threads On The Rod End.</b>
7	19.01011	1	Piston Rod, 5 x 80.5 x 3 Cyl
8	NSS	1	Butt & Tube Assembly, 5 x 80.5 x 3 Cyl
9	19.00130	1	Nut
10	19.00131	1	Piston
11	19.00132	1	Gland
12	19.00133	1	Locking Ring, External Thread
	19.00055	1	Seal Kit
			3" STABILIZER CYLINDER FISHER HYDRAULICS 19.00461 (Replaced by 19.01165.7)
			<b>Identification Feature - Cylinder Assembly Has An Internal Snap Ring On The Rod End.</b>
13	NSS	1	Butt & Tube Assembly
14	19.00743	1	Nut
15	19.00744	1	Piston
16	19.00741	1	Piston Rod
17	19.00745	1	Gland
18	19.00746	1	Snap Ring
	19.00747	1	Seal Kit

# Hydraulic Cylinder (Energy Mfg.) S/N 19.00650 & Up

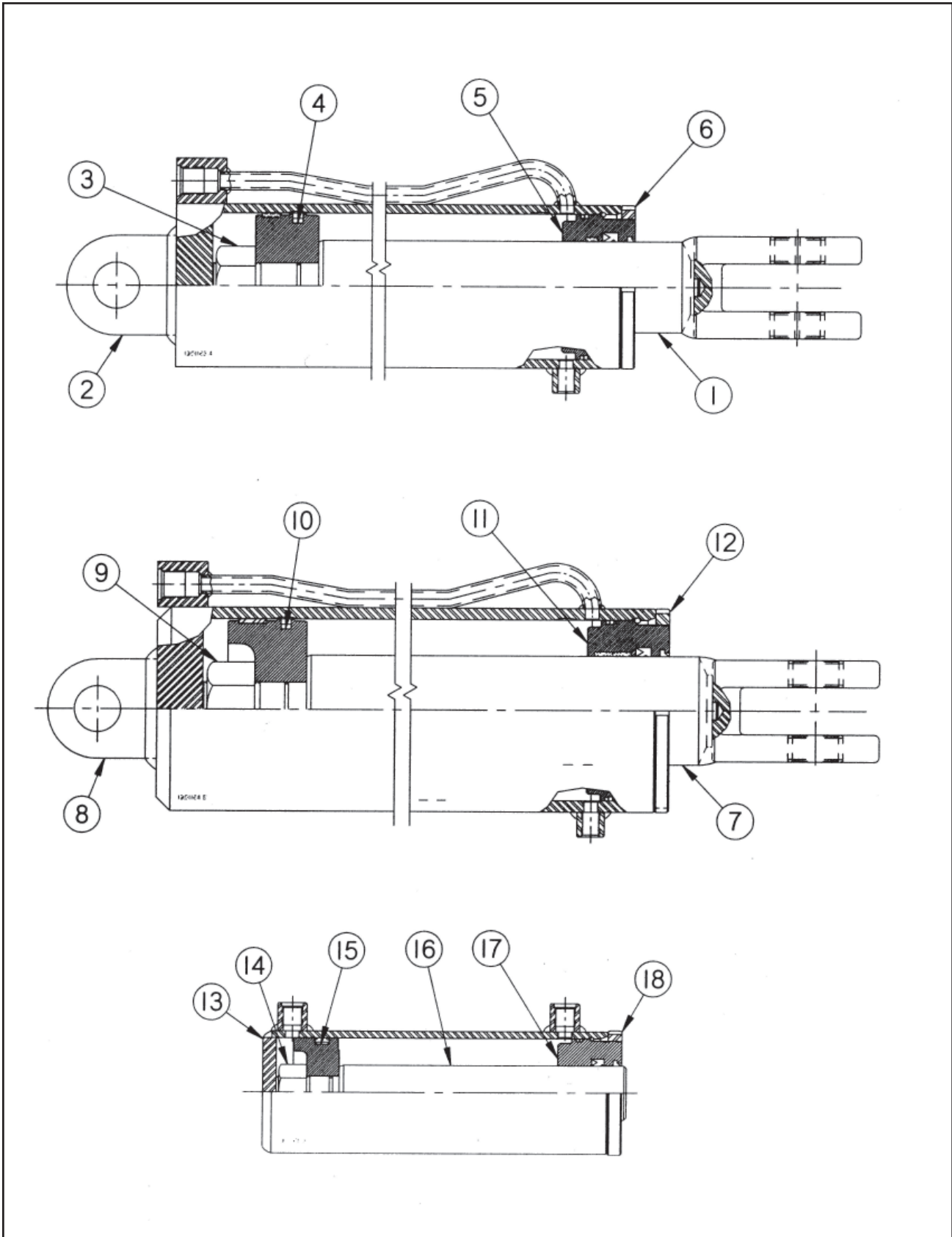

# MILLER PRO

## Hydraulic Cylinder (Energy Mfg.) S/N 19.00650 & Up Parts List

Item	Part No.	Quantity	Description
			4" HYDRAULIC CYLINDER ENERGY MFG 19.01164.7
			<b>Identification Feature - Cylinder Assembly Has A Locking Ring With Internal Threads On The Rod End.</b>
1	19.01173	1	Piston Rod, 4 x 80.5 x 2.50 Cyl
2	NSS	1	Butt & Tube Assembly, 4 x 80.5 x 2.5 Cyl
3	19.01174	1	Nut
4	19.01175	1	Piston
5	19.01176	1	Gland
6	19.01177	1	Locking Ring, Internal Thread
	19.01178	1	Seal Kit
			5" HYDRAULIC CYLINDER ENERGY MFG 19.01163.7
			<b>Identification Feature - Cylinder Assembly Has A Locking Ring With Internal Threads On The Rod End.</b>
7	19.01179	1	Piston Rod, 5 x 80.5 x 3 Cyl
8	NSS	1	Butt & Tube Assembly, 5 x 80.5 x 3 Cyl
9	19.01180	1	Nut
10	19.01181	1	Piston
11	19.01182	1	Gland
12	19.01183	1	Locking Ring, Internal Thread
	19.01184	1	Seal Kit
			3" STABILIZER CYLINDER ENERGY MFG 19.01165.7
			<b>Identification Feature - Cylinder Assembly Has A Locking Ring With Internal Threads On The Rod End.</b>
13	NSS	1	Butt & Tube Assembly
14	19.01186	1	Nut
15	19.01185	1	Piston
16	19.01187	1	Piston Rod
17	19.01188	1	Gland
18	19.01189	1	Snap Ring
	19.01190	1	Seal Kit

# Hydraulic Cylinder (Energy Mfg.) Optional Special Large Diameter Cylinders

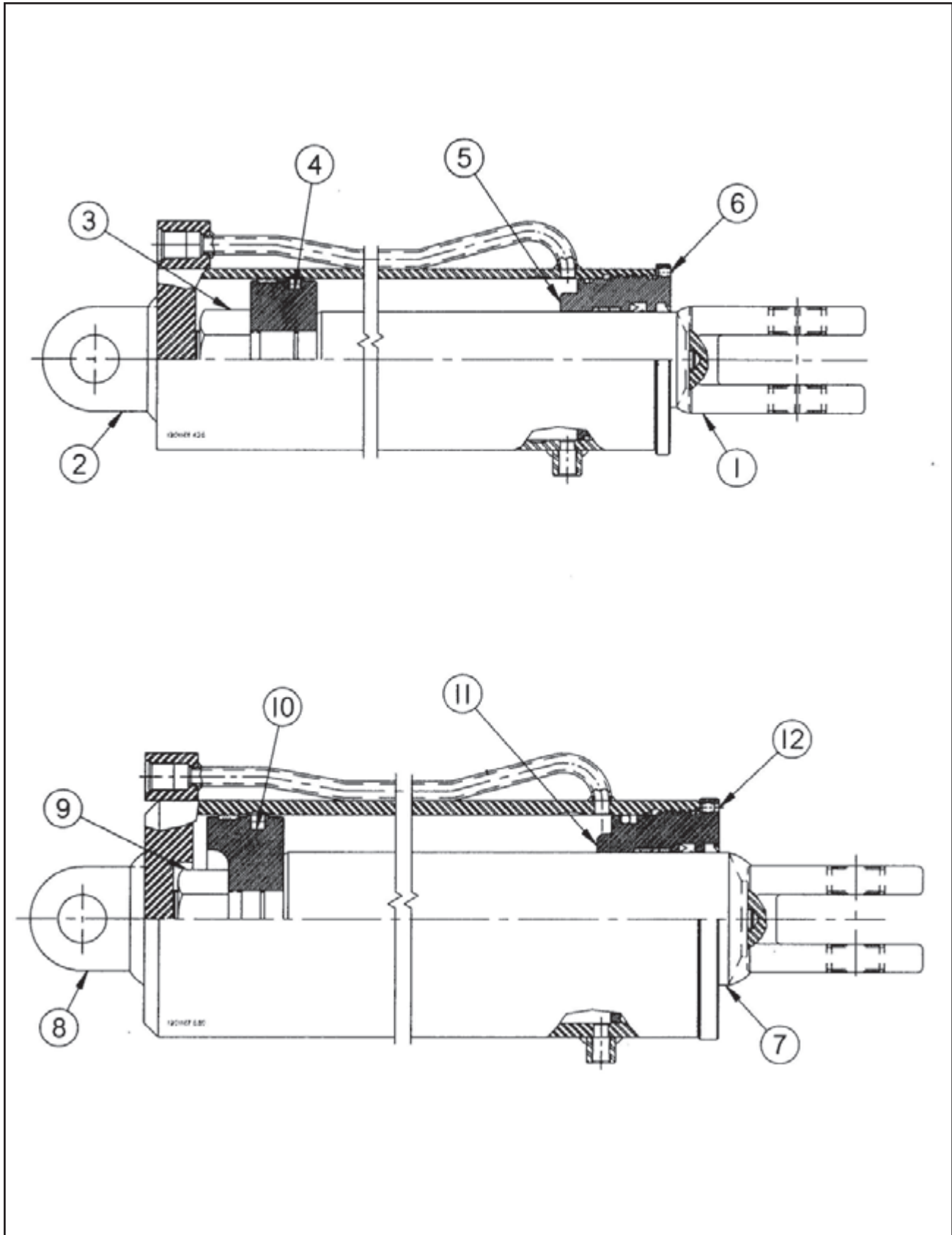

# MILLER PRO

## Hydraulic Cylinder (Energy Mfg.) Optional Special Large Diameter Cylinders Parts List

Item	Part No.	Quantity	Description
			4.25" HYDRAULIC CYLINDER ENERGY MFG 19.01168.7
			<b>Identification Feature - Cylinder Assembly Has A Locking Ring With Internal Threads On The Rod End.</b>
1	19.01191	1	Piston Rod, 4.25 x 80.5 x 2.50 Cyl
2	NSS	1	Butt & Tube Assembly, 4.25 x 80.5 x 2.5 Cyl
3	19.01192	1	Nut
4	19.01193	1	Piston
5	19.01194	1	Gland
6	19.01195	1	Locking Ring, Internal Thread
	19.01196	1	Seal Kit
			5.50" HYDRAULIC CYLINDER ENERGY MFG 19.01167.7
			<b>Identification Feature - Cylinder Assembly Has A Locking Ring With Internal Threads On The Rod End.</b>
7	19.01197	1	Piston Rod, 5.50 x 80.5 x 3.5 Cyl
8	NSS	1	Butt & Tube Assembly, 5.50 x 80.5 x 3.50 Cyl
9	19.01198	1	Nut
10	19.01199	1	Piston
11	19.01200	1	Gland
12	19.01201	1	Locking Ring, Internal Thread
	19.01202	1	Seal Kit

# Electrical

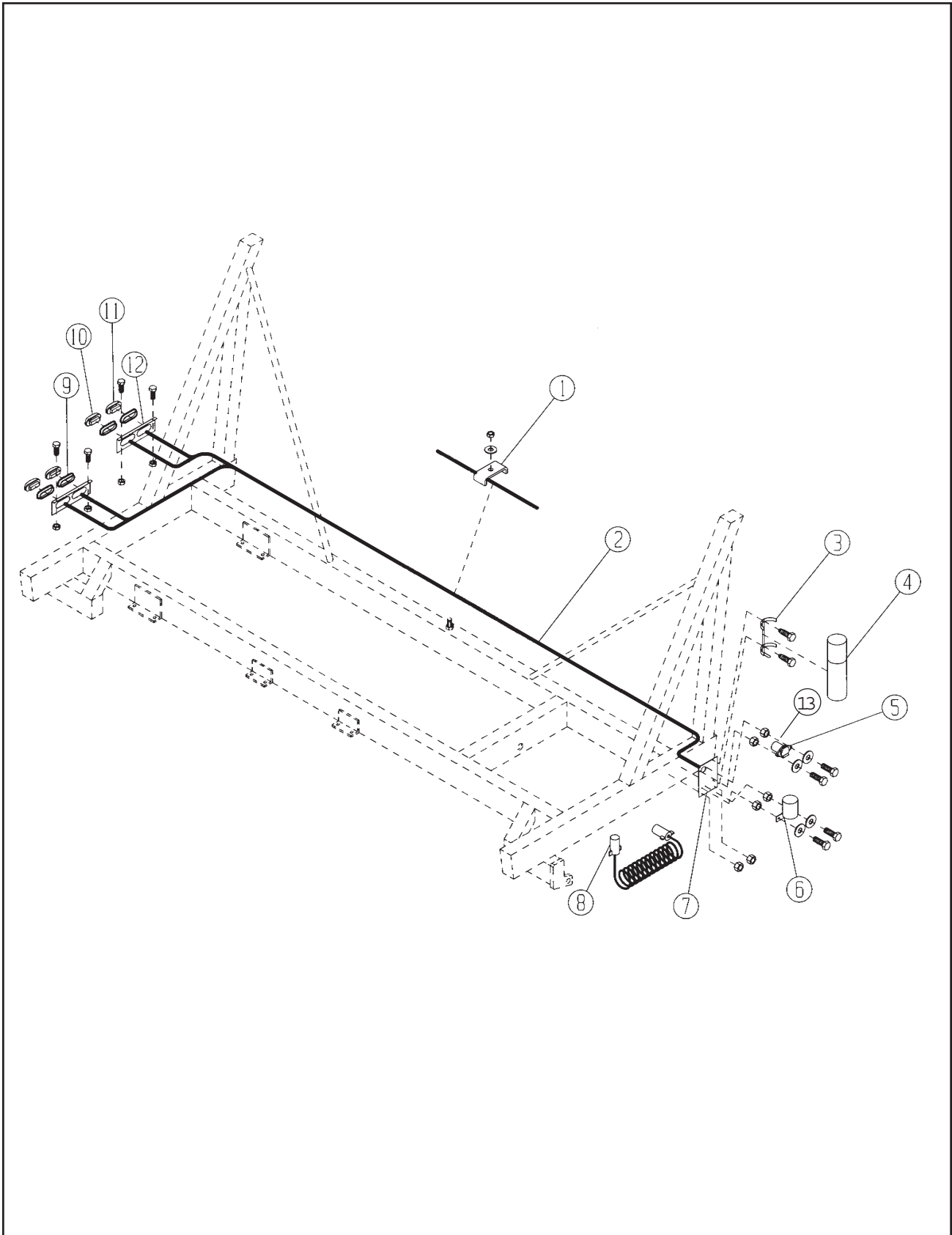



# Brakes

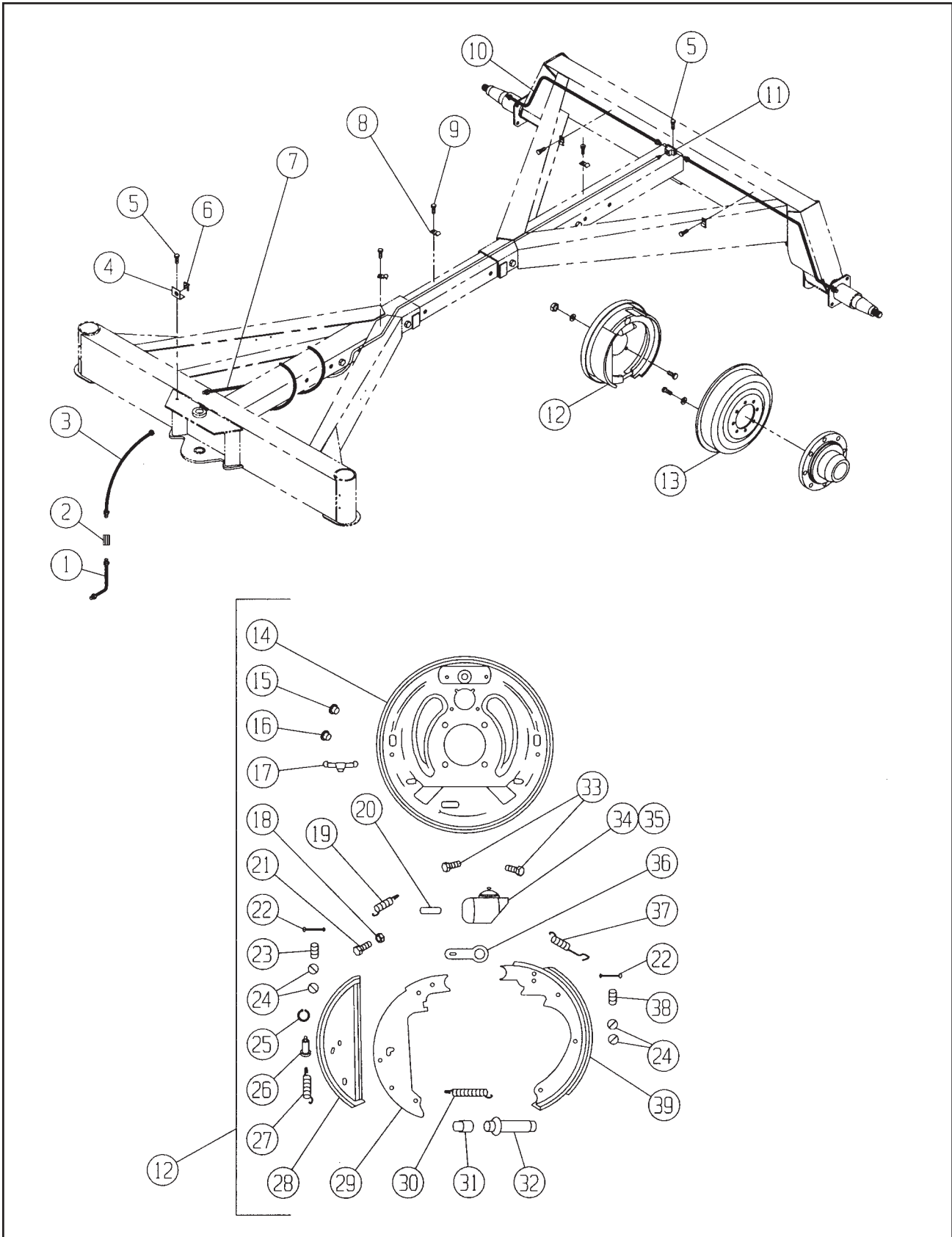



## Brakes Parts List

Item	Part No.	Quantity	Description
1	12.10458	1	Tube, 4-1/2
2	12.10445	1	Union
3	12.10446	1	Hose, 18-7/8
4	12.10448	1	Bracket, Hose
5	09.71112	2	Bolt, Hex, 5/16-18 x 3/4 Self Tap
6	12.10449	1	Hose Clip
7	12.10450	1	Brake Line, 15'
8	12.10454	8	Clip, Brake Line
9	903810	8	Screw, #10 x 3/4 Self Tap
10	12.10451	2	Brake Line, 53"
11	12.10447	1	Tee, w/Bracket
12	903193	1	Brake, Left Backing Plate Assembly
	903292	4	Bolt, Hex, 1/2-20 x 1 Gr 5
	900506	4	Lockwasher, 1/2
	09.70738	4	Nut, Hex, 1/2-20
	903192	1	Brake, Right Backing Plate Assembly (Not Shown)
	903292	4	Bolt, Hex, 1/2-20 x 1 Gr 5
	900506	4	Lockwasher, 1/2
	09.70738	4	Nut, Hex, 1/2-20
13	12.10397.5	2	Brake Drum, 13", 2-3/4 Spindle
	903292	16	Bolt, Hex, 1/2-20 x 1 Gr 5
	900506	16	Lockwasher, 1/2
14	12.10460	2	Back Plate Assembly
15	12.10485	2	Plug, Plastic
16	903259	2	Plug, Plastic
17	903246	2	Cover Plate, Adjusting Hole
18	903936	2	Nut, Hex Lock, 5/16
19	903240	2	Spring, Front Lever (Red)
20	903238	2	Push Rod, Wheel Cylinder
21	903827	2	Bolt, Travel Link
22	903242	4	Pin, Shoe Hold Down
23	903244	2	Spring, Front Lever (Yellow)
24	903243	8	Cup, Shoe Hold Down
25	902854	2	Retaining Ring
26	12.10482	2	Pin, Front Side
27	903258	2	Spring, Front Shoe
28	903229	2	Front Brake Shoe Assembly
29	903230	2	Front Shoe Lever
30	903239	2	Spring, Adjusting Screw (Yellow)
31	903237	2	Socket, Adjusting Screw
32	12.10467	2	Adjusting Screw & Pivot Nut
33	12.10466	4	Screw & Lockwasher
34	903232	1	Wheel Cylinder Assembly, Right
35	903233	1	Wheel Cylinder Assembly, Left
36	903255	2	Travel Link
37	903241	2	Spring, Rear Shoe (Orange)
38	903245	2	Spring, Rear Hold Down (Black)
39	903231	2	Rear Shoe Assembly

# Brake Pole

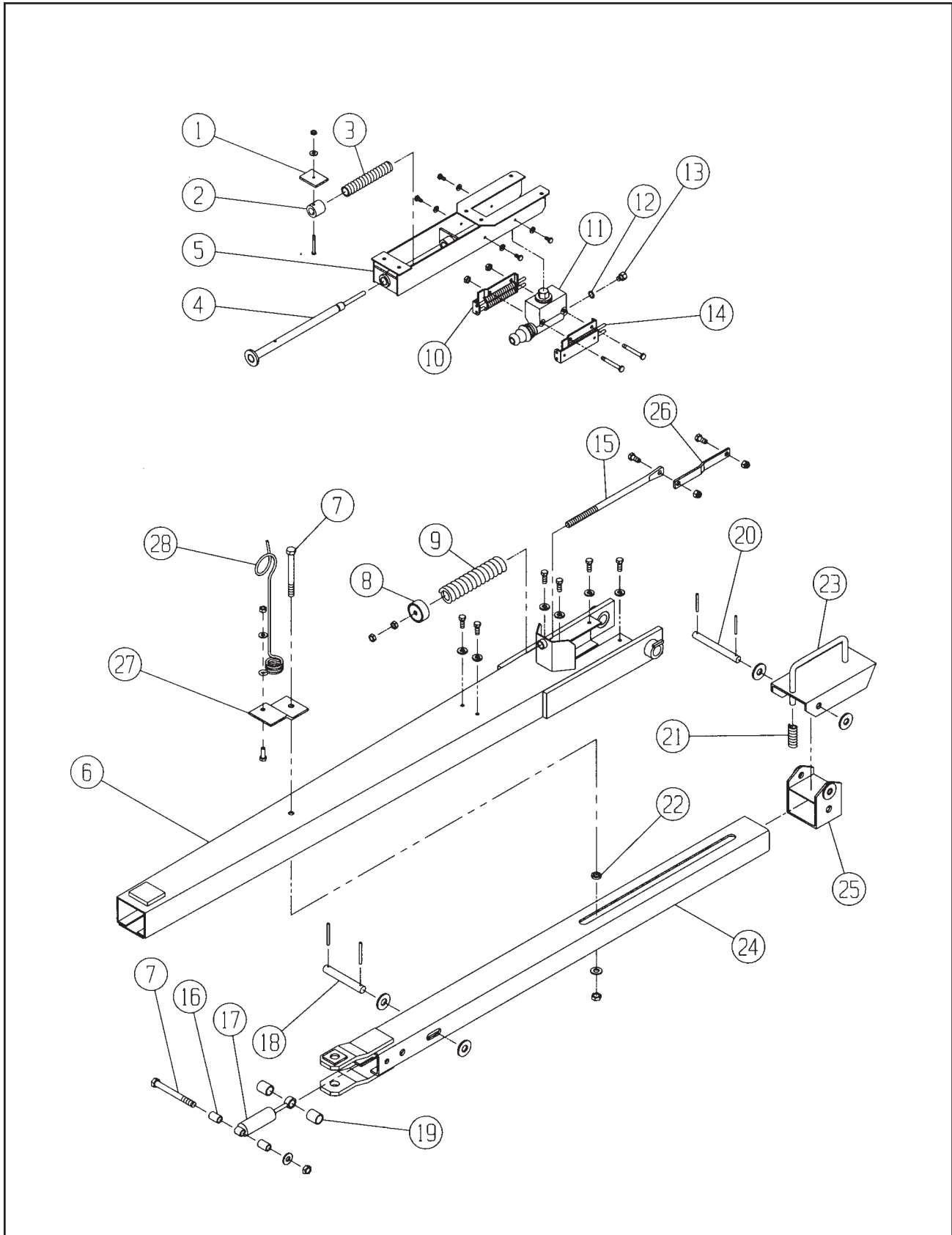

## Brake Pole Parts List

Item	Part No.	Quantity	Description
1	12.10438.5	1	Stop, Inner Bearing
2	12.10433.5	1	Bushing, Bracket Inner
	09.71075	1	Bolt, Hex, 1/4-20 x 2-1/4 Gr 5
	900502	1	Lockwasher, 1/4
	904092	1	Nut, Hex Lock, 1/4-20 Nyl Ins
3	110090A1	1	Spring, Compression
4	12.10434	1	Push Rod, Brake
5	12.10407.5	1	Support, Brake
	900389	4	Bolt, Hex, 5/16-18 x 1/2
	900503	4	Lockwasher, 5/16
6	12.10415.5	1	Pole, Brake
	900397	6	Bolt, Hex, 3/8-16 x 1 Gr 5
	900504	6	Lockwasher, 3/8
7	904217	2	Bolt, Hex, 5/8-11 x 5 Gr 5
	900498	2	Flat Washer, 5/8
	906402	2	Nut, Hex Lock, 5/8-11 Nyl Ins
8	12.10497.7	1	Guide, Spring
9	12.10056	1	Spring, Compression, .38 x 2.0 x 9.25
10	903280	1	Cylinder Brake Assembly, Right
11	12.10440.5	1	Master Cylinder
	902831	2	Bolt, Hex, 3/8-16 x 3 Gr 5
	906400	2	Nut, Hex Lock, 3/8-16 Nyl Ins
12	903212	1	Gasket, Brake
13	903216	1	Connector, Brake
14	903281	1	Cylinder Brake Assembly, Left
15	12.10495	1	Bolt, Spade, 3/4
	900372	2	Nut, Hex, 3/4-10
	900414	2	Bolt, Hex, 1/2-13 x 2 Gr 5
	906401	2	Nut, Hex Lock, 1/2-13 Nyl Ins
16	12.10406.5	2	Spacer, Shock Absorber
17	12.10443.5	1	Shock Absorber, Brake
18	12.10436	1	Pin, 7/8 Brake
	09.70970	2	Flat Washer, 7/8
	09.72003	2	Pin, Roll, 3/16 x 2
19	12.10414.5	2	Spacer, Shock Absorber
20	12.10388	1	Pin, 3/4 x 7
	900499	2	Flat Washer, 3/4
	09.72003	2	Pin, Roll, 3/16 x 2
21	12.10490	1	Spring, Compression
22	12.10048.5	1	Spacer
23	12.10360.7	1	Adjuster
24	12.10410.5	1	Pole, Extension, Brake
25	12.10405.5	1	Pivot, Adjuster, Brake
26	12.10674.5	1	Link, Offset
27	19.00726.7	1	Hose Bracket, Brake Pole
	904871	1	Bolt, Hex, 7/16-14 x 1-1/4 Gr 5
	902915	1	Flat Washer, 7/16
	09.70731	1	Nut, Hex, 7/16-14
28	07.06420.7	1	Hose Bracket

# Tank And Decals

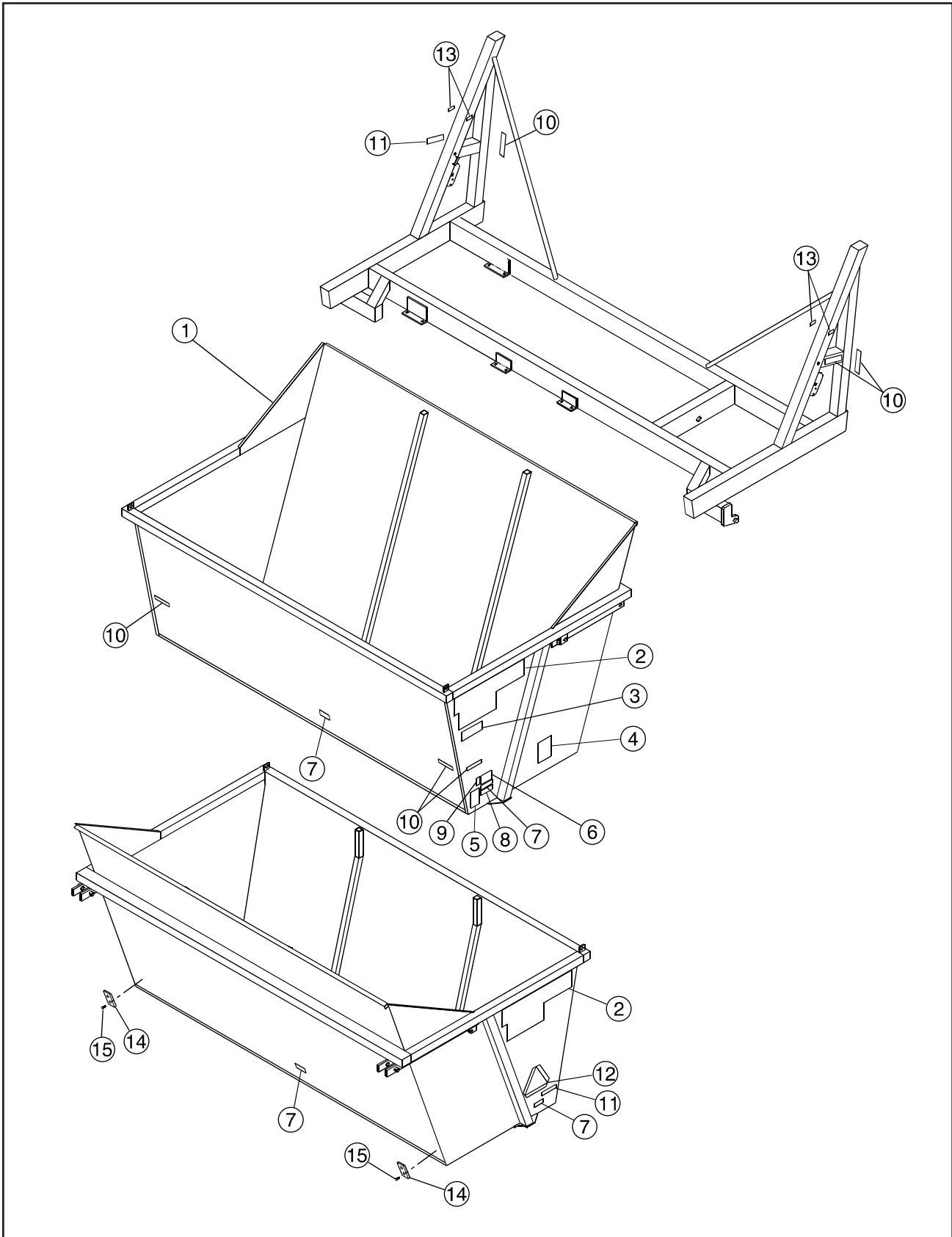



## Part Number Index

Part No.	Page	Part No.	Page	Part No.	Page
07.06420.7	11, 13, 33	12.10449	31	19.00131	23
07.17946	19	12.10450	31	19.00132	23
07.19044	19, 21	12.10451	31	19.00133	23
09.70731	11, 33	12.10454	31	19.00140	35
09.70738	31	12.10458	31	19.00149	19
09.70891	7	12.10460	31	19.00151	19
09.70954	9	12.10466	31	19.00152	11
09.70970	33	12.10467	31	19.00153	19, 21
09.71075	33	12.10482	31	19.00154	19
09.71112	29, 31	12.10485	31	19.00155	19
09.71123	9, 35	12.10490	11, 33	19.00156	11
09.71756	13	12.10495	9, 33	19.00157	19, 21
09.72003	11, 33	12.10497.7	3, 5, 9, 33	19.00251.7	19
09.73710	3	12.10506	11	19.00278	19
09.73906	9	12.10598.7	11	19.00295	11
09.74123	19	12.10603.7	11	19.00304	11
09.74155	21	12.10606.7	9	19.00337	29
100.11100	3, 5	12.10665.7	9	19.00342	29
11.11111	29	12.10674.5	33	19.00365	3, 5
110090A1	33	16.10645	9	19.00400	11
12.00114	11	16.20165	29	19.00480	9
12.09999	11	16.20178	35	19.00492.7	3
12.10048.5	33	16.20191	29	19.00520.7	19
12.10050.7	11	16.20192	29	19.005294	35
12.10056	9, 33	16.20193	29	19.00569	19
12.10303	9	16.20213	29	19.00571	19, 21
12.10304	9	16.20259.7	29	19.00630	19, 21
12.10337.7	11	19.00023	7, 19, 21	19.00642	9
12.10360.7	11, 33	19.00036	35	19.00663.7	3
12.10374	9	19.00039	7	19.00664.7	3
12.10375	9	19.00040.5	7	19.00665.7	9
12.10388	11, 33	19.00045	19	19.00669	9
12.10397.5	31	19.00055	23	19.00684	19
12.10405.5	33	19.00056	23	19.00713.7	11
12.10406.5	33	19.00066	9	19.00716.7	19
12.10407.5	33	19.00068	9	19.00726.7	33
12.10410.5	33	19.00080	9	19.00741	23
12.10414.5	33	19.00081	11	19.00743	23
12.10415.5	33	19.00082	11	19.00744	23
12.10433.5	33	19.00083	11	19.00745	23
12.10434	33	19.00084	11	19.00746	23
12.10436	33	19.00085	11	19.00747	23
12.10438.5	33	19.00113	35	19.00775	3, 5
12.10440.5	33	19.00115	35	19.00779.7	3, 5
12.10443.5	33	19.00124	23	19.00784.7	11
12.10445	31	19.00125	23	19.00799.7	7
12.10446	31	19.00126	23	19.00800.7	35
12.10447	31	19.00127	23	19.00837.7	35
12.10448	31	19.00130	23	19.00843.7	3

## Part Number Index (continued)

Part No.	Page	Part No.	Page	Part No.	Page
19.00844.7	3	19.01011	23	19.01196	27
19.00860.7	9	19.01024.7	13	19.01197	27
19.00861.7	9	19.01039.7	13	19.01198	27
19.00863.7	19, 21	19.01046.7	5	19.01199	27
19.00868.7	9	19.01057.7	13	19.01200	27
19.00869.7	9	19.01095.7	15	19.01201	27
19.00877.7	7	19.01098.7	15	19.01202	27
19.00879.7	7	19.01101.7	15	19.01204	29
19.00880.7	7	19.01121	13	19.800206	19
19.00892.7	7	19.01122	13	19.818724	11
19.00893.7	7	19.01123	13	21.09024	35
19.00898.7	19, 21	19.01124	13	22.37147	9
19.00905.7	7	19.01125	13	24.90180	13
19.00915.7	9	19.01126	13	322848B1.7	19, 21, 29
19.00916.7	11	19.01127	13	40.00321	21
19.00917.7	9	19.01128	13	65.10104	11
19.00918.7	11	19.01129	13	65.10106	11
19.00919.7	9	19.01130	13	65.10108	11
19.00920.7	9	19.01131	13	65.10110	11
19.00924.7	7	19.01132	13	65.10125	11
19.00925.7	7	19.01147.7	17	900143	7
19.00926.7	7	19.01157.7	3, 5	900369	9, 19
19.00927.7	7	19.01158.7	3, 5	900371	3
19.00928.7	7	19.01160	19	900372	9, 33
19.00929.7	7	19.01161	7	900389	33
19.00930.7	3, 5	19.01165.7	19	900397	33
19.00935.7	3	19.01173	25	900414	9, 33
19.00937.7	3	19.01174	25	900493	29
19.00938	3, 5	19.01175	25	900494	7
19.00957	35	19.01176	25	900495	3, 13
19.00958	7	19.01177	25	900497	3, 5, 9, 19
19.00959	35	19.01178	25	900498	3, 15, 33
19.00964	35	19.01179	25	900499	11, 13, 17, 33
19.00966.7	7	19.01180	25	900502	33
19.00970	7	19.01181	25	900503	33
19.00980.7	7	19.01182	25	900504	3, 5, 33
19.00981	3, 5	19.01183	25	900506	3, 5, 9, 19, 31
19.00984.7	3, 5	19.01184	25	900508	3
19.00985.7	3, 5	19.01185	25	900538	9
19.00990	3, 5	19.01186	25	900700	9
19.00994.7	29	19.01187	25	900842	7
19.00995	19, 21	19.01188	25	901105	19, 21, 29
19.00997	19	19.01189	25	901341	3, 5, 7
19.00998	19	19.01190	25	901658	11
19.00999	19	19.01191	27	901937	19
19.01000	19	19.01192	27	902050	19
19.01002	13	19.01193	27	902063	7
19.01004	13	19.01194	27	902291	19, 21, 29
19.01009	23	19.01195	27	902364	3, 5

## Part Number Index

Part No.	Page	Part No.	Page	Part No.	Page
902367	3	904092	29, 33		
902374	9	904172	3		
902603	19	904217	33		
902675	19	904253	9, 15		
902831	33	904777	9		
902854	31	904866	9		
902859	7, 29	904871	11, 33		
902915	11, 33	906349	13, 17		
902928	19	906400	13, 33		
902930	3, 5	906401	3, 5, 7, 9, 15, 33		
903033	29	906402	9, 13, 15, 33		
903192	31	906483	7, 19, 29		
903193	31	907078	13		
903205	11	907120	7		
903212	33	907137	13		
903216	33	907168	21		
903229	31	907215	29		
903230	31	907216	29		
903231	31	907219	35		
903232	31	907220	35		
903233	31	907225	35		
903237	31	907510	35		
903238	31				
903239	31				
903240	31				
903241	31				
903242	31				
903243	31				
903244	31				
903245	31				
903246	31				
903255	31				
903258	31				
903259	31				
903280	33				
903281	33				
903292	31				
903300	7				
903423	13, 17				
903517	7				
903518	15				
903772	19				
903810	31				
903827	31				
903832	3, 15				
903853	3, 5				
903936	31				
903937	7				
903993	13				







© 2004 by Miller-St. Nazianz, Inc.