

MILLER PRO

FORAGE BLOWER MODEL 1060 SERIES II

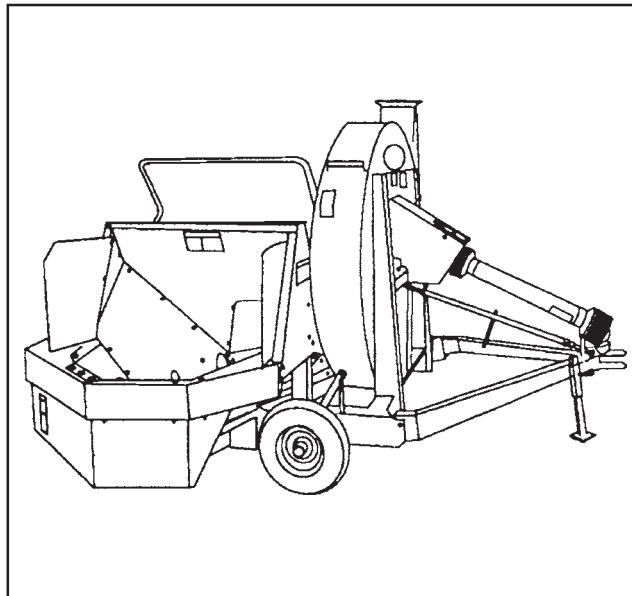

OPERATOR'S MANUAL

**DO NOT OPERATE THIS EQUIPMENT UNTIL THIS
MANUAL HAS BEEN READ AND UNDERSTOOD.**

23.00004F
7/05



Art's-Way Manufacturing Co., Inc.
P.O. Box 288
Armstrong, IA 50514
Tel. 712-864-3131
FAX: 712-864-5154

GENERAL INFORMATION

The purpose of this manual is to assist the operator in maintaining and operating the Forage Blower. Read it carefully: it furnishes information and instructions that will help you achieve years of dependable service.

All replacement parts should be obtained from or ordered through your Miller dealer. Give complete information when ordering service parts including the model number and serial numbers. Record numbers in the space provided as a handy record for quick reference.

Model No. _____ **Serial No.** _____

Date Purchased _____

Model and Serial Numbers are located on the rear main frame channel.

Art's-Way Mfg. reserves the right to make improvements in design, or changes in specifications at any time, without incurring any obligation to owners of units previously sold.

IDENTIFYING TERMS

“LEFT” and “RIGHT” are determined from a position standing at the rear of the unit looking toward the direction of travel. From this position the hopper or in-feed is on the “Right” side. “FRONT” is the tongue end and “REAR” is the trailing end when the tractor is traveling forward.

TRACTORS

This Operator’s Manual uses the term “Tractor” when identifying the power source for the forage blower. However, the same safety and operating practices apply to other power sources such as hydraulic and electric motors.

WARRANTY REGISTRATION

The **DELIVERY AND WARRANTY REGISTRATION CARD** found in the front of this manual must be completed and signed to validate your warranty protection. You must read and understand the places where you attest to having received instructions as to care, adjustments, safe operation and applicable warranty policy. The terms and conditions of the warranty are specified on the rear cover of this manual.

WARNING

SOME PHOTOGRAPHS USED HEREIN MAY SHOW DOORS, GUARDS AND SHIELDS OPENED OR REMOVED. BE SURE THAT ALL DOORS, GUARDS AND SHIELDS ARE FASTENED IN THEIR PROPER POSITION BEFORE MACHINE IS OPERATED!

TABLE OF CONTENTS

General Inside Front Cover	Adjustments 28
Identification Numbers	Check Fan Tip Clearance 28
Warranty Registration Information	Fan Paddle 29
Forage Blower Inspection	Paddle Clearance 29
Checklist 4	Paddle Replacement 30
Safety Precautions for the Farm 7-11	Housing Band 30
Safety Decals 12-14	Shear Bar Adjustment 31
Replacement of Decals 14	Auger Drive Belts 31
Introduction 15	Belt Tension-Drive Shaft 31
Intended Use 15	Belt Tension-Augur Drive 32
Tractor/Blower Preparation 16-17	Auger Clearance 33
Tractor Specifications 16	General 33
Tractor Drawbar/Power Take-Off	Shear Bolts 33
Requirements 16-17	Lubrication and Maintenance 34-35
Attaching Blower to Tractor 18	Power Take-Off 34
Telescopic Power Take-Off	Pillow Block Bearings 34
Shaft Assembly 18	Shear Device 34
Drive Overload Protection 19	Auger Bearings 34
Adjusting Hopper Height 19	Auger Drive Shaft 35
Leveling the Forage Blower 20	Idler Pivot 35
Positioning the Forage Blower 21	Clutch Linkage 35
Pipe Assembly 21	Wheels 35
Access to Operator Area 22	1000 RPM Gearbox 35
Rotating Blower Outlet 22	Bolt Torque Specificatons 36
Operation 23	Troubleshooting 37
Checklist 23	Specifications 38
Starting 24	Warranty Inside Rear Cover
Blower Fan Speed 24	
During Operation 24	
Adding Water 24-25	
Air Control Baffle 25	
Shutdown of Blower 25	
Unplugging of Blower or Pipes 25	
Highway Safety Chain 26	
Transporting Blower 26	
Storage Instructions 27	

FORAGE BLOWER

PRE-DELIVERY CHECK LIST

After the Forage Blower has been completely set-up, check to be certain it is in correct running order before delivering it to the customer. The following is a list of points to inspect. Check off each item as you have made the proper adjustments and found the item operating satisfactorily. Any adjustment must be made according to specifications defined in this manual.

- All shields and guards are in place and fastened.
- All covers are closed and latched.
- Blower band tightened, per instructions on pages 28-30.
- All grease fittings have been lubricated. See "lubrication" section in this manual, pages 34-35
- Auger clearances are properly adjusted. See instructions, page 33.
- All drive belts are at proper tension. See "Adjustments" section in this manual, pages 31-32.
- All bolts and other fasteners are tight.
- PTO shields turn freely and proper shear bolts are installed.
- Fan shear bar and auger are adjusted properly. See "Adjustments" section in this manual.

Dealer's Name

Signature of Pre-Delivery Inspector

Date of Inspection

Model No.

Serial No.

DELIVERY CHECK LIST

The following check list is an important reminder of valuable information that MUST be passed on to the customer at the time the unit is delivered. Check off each item as you explain it to the customer

- Give the customer the Operator's Manual. Instruct them to be sure to read and completely understand its contents BEFORE attempting to operate the unit.
- Explain the precautionary statement section of the manual
- Explain and review with the customer how to tighten and importance of keeping blower band tight, pages 28-30 in this manual.
- Explain that regular lubrication and proper adjustments are required for continued proper operation and long life. Review with the customer the Maintenance and Adjustments in the section of this manual.
- Advise the customer to check both belts for proper tension after the second load has been unloaded and to continue to check the tension until the initial stretch in the belts disappears.
- Complete the Delivery Registration Card and have customer sign it and return it to Art's-Way Manufacturing.
- Explain the use of water to prevent gum build up inside blower.

Explain the warranty.

I acknowledge that above points were reviewed with me at the time of delivery.

Customer's Signature

Date Delivered

(Customer Copy)

FORAGE BLOWER

PRE-DELIVERY CHECK LIST

After the Forage Blower has been completely set-up, check to be certain it is in correct running order before delivering it to the customer. The following is a list of points to inspect. Check off each item as you have made the proper adjustments and found the item operating satisfactorily. Any adjustment must be made according to specifications defined in this manual.

- All shields and guards are in place and fastened.
- All covers are closed and latched.
- Blower band tightened, per instructions on pages 28-30.
- All grease fittings have been lubricated. See "lubrication" section in this manual, pages 34-35
- Auger clearances are properly adjusted. See instructions, page 33.
- All drive belts are at proper tension. See "Adjustments" section in this manual, pages 31-32.
- All bolts and other fasteners are tight.
- PTO shields turn freely and proper shear bolts are installed.
- Fan shear bar and auger are adjusted properly. See "Adjustments" section in this manual.

Dealer's Name _____

Signature of Pre-Delivery Inspector _____

Date of Inspection _____

Model No. _____

Serial No. _____

DELIVERY CHECK LIST

The following check list is an important reminder of valuable information that MUST be passed on to the customer at the time the unit is delivered. Check off each item as you explain it to the customer

- Give the customer the Operator's Manual. Instruct them to be sure to read and completely understand its contents BEFORE attempting to operate the unit.
- Explain the precautionary statement section of the manual
- Explain and review with the customer how to tighten and importance of keeping blower band tight, pages 28-30 in this manual.
- Explain that regular lubrication and proper adjustments are required for continued proper operation and long life. Review with the customer the Maintenance and Adjustments in the section of this manual.
- Advise the customer to check both belts for proper tension after the second load has been unloaded and to continue to check the tension until the initial stretch in the belts disappears.
- Complete the Delivery Registration Card and have customer sign it and return it to Art's-Way Manufacturing.
- Explain the use of water to prevent gum build up inside blower.
- Explain the warranty.

I acknowledge that above points were reviewed with me at the time of delivery.

Customer's Signature _____

Date Delivered _____

(Dealer Copy)

This page intentionally left blank

PRECAUTIONARY STATEMENTS

PERSONAL SAFETY

Throughout this manual and on machine decals, you will find precautionary statements followed by specific instructions. These precautions are intended for the personal safety of you and those working with you. Please take the time to read them.



CAUTION

The word CAUTION indicates a potentially hazardous situation which, if not avoided, may result in minor or moderate injury. It may also be used to alert against unsafe practices.



WARNING

The word WARNING indicates a potentially hazardous situation which, if not avoided, could result in death or serious injury, and includes hazards that are exposed when guards and shields are removed. It may also be used to alert against unsafe practices.



DANGER

The word DANGER indicates an imminently hazardous situation which, if not avoided, will result in death or serious injury. The word DANGER is limited to the most extreme situations.

Failure to follow the CAUTION, WARNING, and DANGER instructions may result in serious bodily injury or death.

MACHINE SAFETY

Additional precautionary statements are followed by specific instructions. These statements are intended for machine safety.

Attention

The word ATTENTION is used to warn the operator of potential machine damage if a certain procedure is not followed.

Important

The word IMPORTANT is used to inform the reader of something he needs to know to prevent minor machine damage if a certain procedure is not followed.

SAFETY PRECAUTIONS FOR THE FARM

PERSONAL INJURY MAY RESULT IF THESE PRECAUTIONS ARE NOT FOLLOWED

The safety of the operator is one of the main concerns in machine design. However, every year many accidents occur which could have been avoided by a few seconds of thought and a more careful approach to handling farm machinery and implements. You, the operator, can avoid many accidents by observing the following precautions and insist those working with you and for you follow them.

In order to provide a better view, certain illustrations in this manual may show an assembly with the safety shield removed. However, a machine should never be operated in this condition. Keep all shields in place. If shield removal becomes necessary for repairs, replace shield prior to machine operation.

- MAKE SURE all safety shields and covers are securely in place when machine is operating.
- Do not operate machine without power take-off shaft shields installed.
- BE CAREFUL and use caution when transporting machine, especially on highways or rough roads.
- MAKE SURE tractor engine is stopped and power take-off is disengaged before carrying out lubrication, adjustments, repairs, etc.
- MAKE SURE that the operator is the only person on the tractor and nobody is on the Forage Blower or Forage Box when they are operating or in motion.
- KEEP CLEAR of discharge when unit is operating. Ensure all persons around machine observe this precaution.
- BE PARTICULAR about matching operating speed to terrain. Reduce speed when operating on rough or hilly ground.
- BE ALERT for people and /or animals, in front or around machine, when about to start machine.
- Transport gear is designed and rated for maximum speed of 20 MPH.
- BE EXTRA CAREFUL when going through fence gates or nearing confined quarters. Be especially careful to prevent ends from hooking fixed objects.
- Keep all shields in place.
- Keep hands, feet and clothing away from power driven parts.
- BE PARTICULAR about loose clothing. This catches easily in moving parts.
- STOP TRACTOR ENGINE before doing any checks, adjustments, repairs, lubrication or clearing any obstruction, or when leaving tractor for any reason.
- When driving tractor and unit on a road or highway, whether at night or during the day, use accessory lights. Use of a flashing amber light is acceptable in most localities. However, some localities prohibit the use of them. Local laws should be checked for all highway lighting and marking requirements.
- A rear-facing SMV emblem should be displayed on rear of Forage Blower. SMV emblem should be kept clean and intact.
- REMEMBER: SAFETY is only a word until it is put into practice.

SAFETY PRECAUTIONS FOR THE FARM

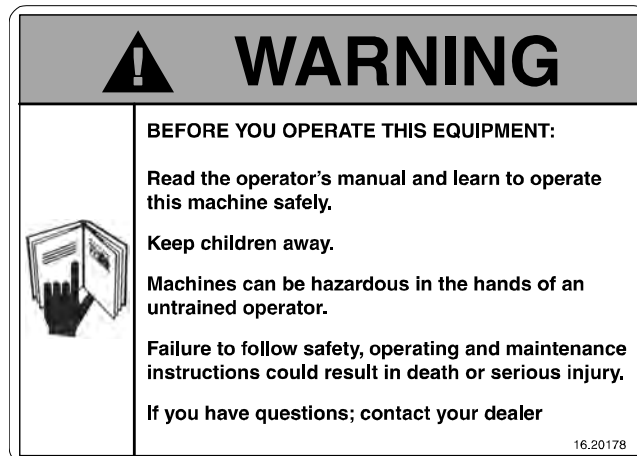

KNOW THE RULES. Read this manual carefully and follow all safety recommendations. Check for the meanings of all signs, flag markings, signals and safe operating practices. **KNOW THE RULES-LIVE BY THEM.**

PROTECT YOURSELF. Wear all protective clothing and personnel safety devices. You may need a hard hat, safety shoes, safety glasses, personal hearing protection, heavy gloves, etc.

KNOW YOUR EQUIPMENT. Know your machine, study the manual and play it safe. Make sure you **KNOW** how it operates and **WHAT IT CAN AND CAN NOT DO.**

CHECK YOUR WORK AREA. Inspect the surface over which you will travel. Look for deep holes, drop offs, large obstacles, wet, slippery surfaces, overhead clearance, electrical lines and terrain. **KEEP ALERT. AVOID HAZARDOUS CONDITIONS.**

CLEAN UP. Keep your work area and machine clean, wipe up grease and oil, brush away dust or mud, scrape away snow and ice. Slippery surfaces can be **DANGEROUS.**

MAKE THE RIGHT START. Be certain that you have the right machine to do the job.

INSTRUCT EMPLOYEES. Be certain that your employees or members of your family who will operate this unit have read and understand this manual and are fully familiar with the operation of the unit.

WATCH OUT FOR OTHERS. Always be aware of what is going on around your area. Be alert. Watch out for others who may cause you trouble by their carelessness. Never permit riders on your equipment. Yours is a one-man machine. Never permit an unqualified person to operate your machine. **WATCH OUT FOR OTHERS.**

MOUNT PROPERLY. Mount tractor slowly. Always clean your shoes and wipe your hands before climbing on and operating any controls. Start safely from operator's seat. Never start up until you have warned others from area. **THINK SAFETY.**

WORK SAFELY. Whenever possible, work on level surface. Avoid steep hills, slopes, ramps, and grades. Be especially careful when working on hillsides. Travel slowly over rough terrain. Avoid sharp turns or climbing steep slopes. Never travel with obstructed vision.

WATCH OUT FOR OBSTACLES. Adjust your speed to the conditions of the terrain. Watch out for rocks and stumps. Avoid soft edges, deep holes, and steep grades. Stay in gear when traveling downhill. Reduce speed when operating in smoke, dust, or fog.

TRANSPORTING PROCEDURES. If it is necessary to transport machine over public roads or streets, be sure all local and state regulations covering transport of your equipment are followed. **MOVE CAREFULLY. MOVE SAFELY.**

SAFETY PRECAUTIONS FOR THE FARM

WATCH OUT FOR TRAFFIC. Make sure all required safety pins and chains are in place and secure. Never travel faster than is appropriate for conditions. Avoid injuries to you and others.

RULES OF THE ROAD. If the machine is to be towed over the road, refer to the instructions in this manual for specific preparation instructions. Be sure that clearance flags, flashing lights, and warning signs are in place. Make sure the slow moving emblem is clearly visible at a distance to any vehicle approaching from the rear. Obey all traffic regulations, use turn signals when turning, approach all intersections with caution, observe all speed and traffic control signs. Avoid panic braking. Travel with caution.

SAFE PARKING. Always park your machine on a level and non-operating or designated parking area. If parking on a slope is necessary, position the machine at right angles to the slope.

SAFE DISMOUNTING. Always bring tractor to a complete stop before dismounting. Shut off the engine. Dismount carefully. Check for slippery conditions on steps or ground.

SAFE MAINTENANCE

PROTECT YOUR EYES. Wear eye protection. Wear safety glasses or goggles to protect your eyes from fuel or solvents. Wear goggles or a face shield when you grind or drill on metal parts. Wear a proper helmet or goggles when you weld, cut or burn.

PREPARE THE REPAIR WORK AREA. Choose a clean and level work area. Make sure there is enough room and adequate light and ventilation. Keep the floor and work surface clean. Wipe up oil and grease and sand slippery areas. Make sure you have the correct tools and keep them clean. Be sure the necessary jacks and hoists are in good order. Don't do any heavy lifting alone. A GOOD MECHANIC CAN BE IDENTIFIED BY THE CONDITION OF HIS TOOLS.

PREPARE THE MACHINE. Move the machine onto a level surface. Shut off the engine and operate controls to release all hydraulic pressure. Never work with the engine running. Remove only those guards or covers that prevent access to the equipment needing repair. **BE CERTAIN THAT GUARDS ARE REPLACED.**

USE JACKS AND HOISTS CAREFULLY. Be certain that the hoists or jacks you use have adequate lifting capacity and are in good repair. Position jacks and hoists carefully, lift slowly and only as much as is needed for clearance. When working beneath raised equipment, never depend on the hoist or jack alone; always use substantial blocks. Such blocks as concrete blocks are inadequate.

AVOID FIRE AND EXPLOSION HAZARDS. Always work in a well ventilated area. Make sure you know where the fire extinguishers are kept and how to use them. Use a non-flammable solvent to clean parts instead of gasoline or diesel fuel.

AVOID ELECTRICAL HAZARDS. Never use wet, worn or frayed power cords. Don't use electrical equipment in wet areas. Be sure all electric drills, drivers, wrenches, hoists, grinders and other power tools are correctly wired and properly grounded. Never touch bare wires without first making sure they are not carrying current. In case of electrical fires, use a CO2 fire extinguisher.

POWER SOURCE SHUTDOWN PROCEDURE

Before cleaning, unclogging, adjusting, lubricating or servicing this machine:

1. Disengage the tractor PTO.
2. Shut off the tractor engine, remove the starter key and take it with you.
3. Wait for all machine motion to stop
4. Remove ALL power connections from the tractor.

Failure to follow these precautions could result in death or serious injury.

SAFETY PRECAUTIONS FOR THE FARM

BE CAREFUL WITH FLUIDS UNDER PRESSURE

The hydraulic system is under pressure whenever the engine is running, and may hold residual pressure even after shutdown. Before working on any pressurized system, relieve all operating and residual pressures. To relieve the pressure in the hydraulic system, cycle all controls after shutdown.



CAUTION

Hydraulic systems are highly pressurized and must be approached with great care. Hydraulic pressure can drive hydraulic fluid through the skin. Check for leaks in a hydraulic system with a piece of wood or scrap cardboard and not your bare hands. If a pinhole leak injects hydraulic fluid into your body, see a physician immediately.

DON'T TAKE CHANCES. Tighten all bolts, fittings, and connections to torque values specified by the manufacturer. Replace all guards, covers and shields. Refill and recharge pressure systems only with manufacturer approved fluids. Check your work, clean up and recheck oil, hydraulic fluid and all other service points before restarting.

ONE FINAL WORD. It is impossible, within this manual, to cover every hazardous situation you may encounter. But, your knowledge of these safety precautions and your adherence to the basic rules of safety will help build good judgement in all situations. Our object is to help you develop safe operating, maintenance and repair procedures. **REMEMBER: SAFETY IS YOUR BUSINESS AND YOUR RESPONSIBILITY.**

DON'T TAKE CHANCES. Use the correct tools. Make sure wrenches and drivers are properly sized and fitted. Don't use broken, damaged or badly worn parts. Don't change sealed relief valve settings. Do not reset an adjustable relief valve for a pressure higher than recommended by the manufacturer. Do not close off overflow or bypass lines. Replace all filters and screens.



Look for this symbol to point out important safety precautions. It means ATTENTION! BECOME ALERT! YOUR SAFETY IS INVOLVED.

SAFETY DECALS

! WARNING

BEFORE YOU OPERATE THIS EQUIPMENT:

Read the operator's manual and learn to operate this machine safely.

Keep children away.

Machines can be hazardous in the hands of an untrained operator.

Failure to follow safety, operating and maintenance instructions could result in death or serious injury.

If you have questions; contact your dealer

16.20178

! CAUTION

OPERATE ONLY WITH
540 RPM PTO
KEEP ALL GUARDS AND SHIELDS
IN PLACE DURING OPERATION.

340248B1

! WARNING

ROTATING FAN BLADES CAN INJURE OR DISMEMBER.
STAY AWAY
FAN ROTATION CONTINUES AFTER POWER IS DISENGAGED.

LOOK AND LISTEN FOR EVIDENCE OF ROTATION. DO NOT REMOVE GUARDS, BLOWER THROAT, OR PIPE UNTIL FAN HAS COMPLETELY STOPPED.
FAILURE TO HEED COULD RESULT IN DEATH OR PERSONAL INJURY.

337143B2

! DANGER

ROTATING AUGER CAN KILL!
STAY AWAY

DO NOT ATTEMPT TO RE-POSITION FEED WHILE MACHINE IS RUNNING.
DO NOT ATTEMPT TO STRADOLE OR STAND ON HOPPER ASSEMBLY.

YOU CAN SLIP AND BE CAUGHT IN THE AUGER
FAILURE TO HEED WILL RESULT IN DEATH OR PERSONAL INJURY.

331865B1

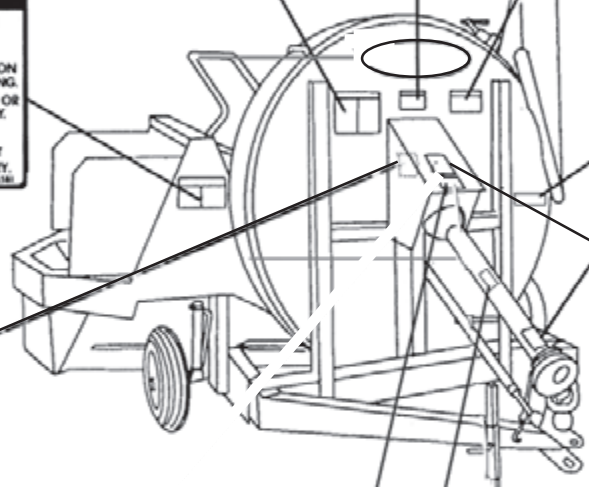

907220
YELLOW REFLECTOR

! DANGER

ROTATING DRIVELINE
CONTACT CAN CAUSE DEATH
KEEP AWAY!

DO NOT OPERATE WITHOUT —

- ALL DRIVELINE, TRACTOR AND EQUIPMENT SHIELDS IN PLACE
- DRIVELINES SECURELY ATTACHED AT BOTH ENDS
- DRIVELINE SHIELDS THAT TURN FREELY ON DRIVELINE

329594B2

! WARNING

SHIELD IS OFF

REPLACE SHIELD BEFORE OPERATING

FAILURE TO HEED COULD RESULT IN DEATH OR PERSONAL INJURY

331096B2

336957B1

TRACTOR DRAWBAR
ADJUSTMENT

540 RPM PTO 1 3/8(35mm)

14 IN(356mm)

SEE TRACTOR OPERATOR'S MANUAL FOR ADJUSTMENT INSTRUCTION
ALWAYS KEEP IMPLEMENT HITCH PINNED TO TRACTOR DRAWBAR

336957B1

! DANGER

SHIELD MISSING DO NOT OPERATE

! DANGER

SHIELD MISSING DO NOT OPERATE

! DANGER

331639B2

SAFETY DECALS

337143B2



331101B2



313865B1



331096B2



RED REFLECTOR
907219

YELLOW REFLECTOR
907220

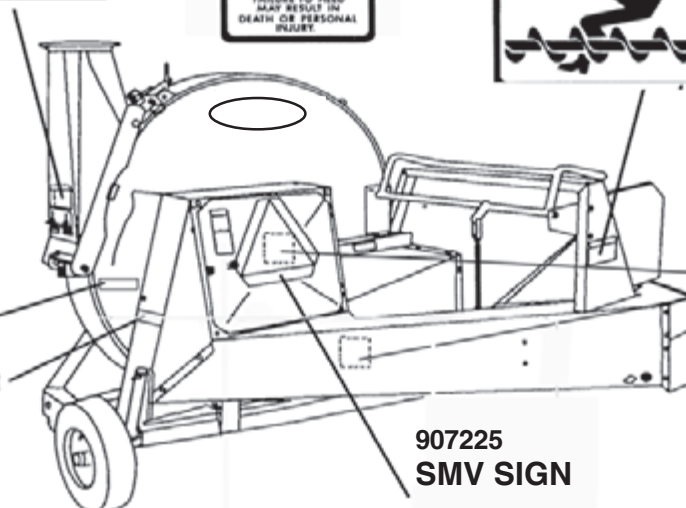

907225
SMV SIGN

329594B2



344243B1

TRACTOR DRAWBAR
ADJUSTMENT

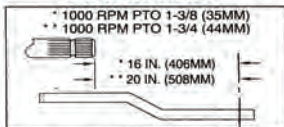

SEE TRACTOR OPERATOR'S MANUAL FOR ADJUSTMENT INSTRUCTION ALWAYS KEEP IMPLEMENT HITCH PINNED TO TRACTOR DRAWBAR

344243B1



344428B1



340250B1

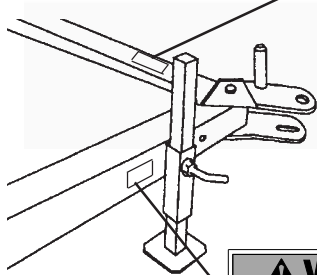

17.01155

SAFETY DECALS

337145B1



336885B1



331865B1



RED REFLECTOR
907219



331101B2



331096B2



331865B1

YELLOW REFLECTOR
907220

REPLACEMENT OF DECALS

Check all safety decals and replace any that are worn, missing or illegible. Decals may be ordered from your Miller Dealer.

An SMV sign MUST be displayed when unit is towed on public roads at slow speeds. Check local codes for specific requirements.

INTRODUCTION

This Forage Blower is a heavy-duty, high capacity machine which blows all types of forage with equal ease, haylage, light hay, silage or grain are all blown with a minimum of plugging or spillage. The auger, formed paddles and the air regulator door ensure a smooth material flow from the hopper through the pipe.

This Forage Blower was designed to utilize the power of larger tractors for much faster blowing rates and filling center-fill soils. All types of material are blown up a 9" pipe in a smooth continuous flow.

This Forage Blower has many time and effort saving features. Maintenance is held to an absolute minimum. Operation requires attention to only one lever on the Forage Blower, the tractor power take-off lever and the controls on self-unloading box or conveyor. One man can handle large loads in short periods of time.

Re-lube fan shaft bearings are used to ensure long life and safety is assured, with safety shields at points which might be hazardous.

A complete line of accessories and attachments are available for the Forage Blower from your local Dealer.



WARNING

Some illustrations in this manual show the Forage Blower with guards and shields removed to show details. Be sure all guards and shields are in place before operating the Forage Blower. If this practice is not followed, serious injury or death could result.

INTENDED USE

This Forage Blower is designed solely for use in normal agricultural operations of blowing ensilage into a silo or barn. Use in any other manner will be considered as contrary to the intended use. Miller accepts no liability for damage or injury resulting from such misuse, and these risks must be borne solely by the user. Compliance with and strict adherence to the conditions of operation, service and repair as specified by Miller, also constitute essential elements of intended use.

This Forage Blower should be operated, serviced and repaired only by people familiar with all its particular characteristics and acquainted with the relevant safety procedures.

The accident prevention regulations and all other generally recognized regulations on safety and occupational medicine and road traffic regulations must be observed at all times.

Any arbitrary modifications carried out on this Forage Blower may relieve Art's-Way Mfg. of any liability for any resulting damage or injury.

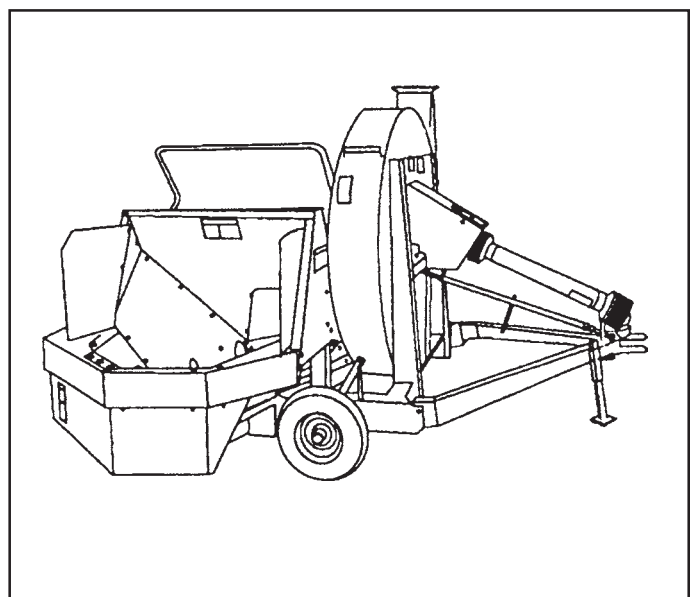

Figure 2. BN2060 Forage Blower

TRACTOR/BLOWER PREPARATION

TRACTOR SPECIFICATIONS

This Forage Blower is designed for a normal operating power take-off speed of 540 RPM. When forage blower is equipped with optional 1000 RPM gear box, the power take-off speed is 1000 RPM. The tractor should be checked to insure that it is operating at recommended speed when the Forage Blower is under load.

However, the tractor used to power the Forage Blower must meet certain requirements.

It is recommended that a tractor with a minimum of 80 HP at 540 RPM or 140 HP at 1000 RPM be used with the Forage Blower. Higher HP rated tractors may be more desirable if tough materials, such as wilted hay or heavy materials, are to be blown. More HP may also be needed on higher silos.

The tractor should be in good condition and transmit an even flow of power. Tractors with an improperly tuned engine and slow reacting governors that permit excessive drop in speed will overload the power take-off and continuously shear bolts in the shear bolt protection assembly. Life of the power take-off is greatly reduced if this is a frequent occurrence.

ASAE P.T.O. STANDARD

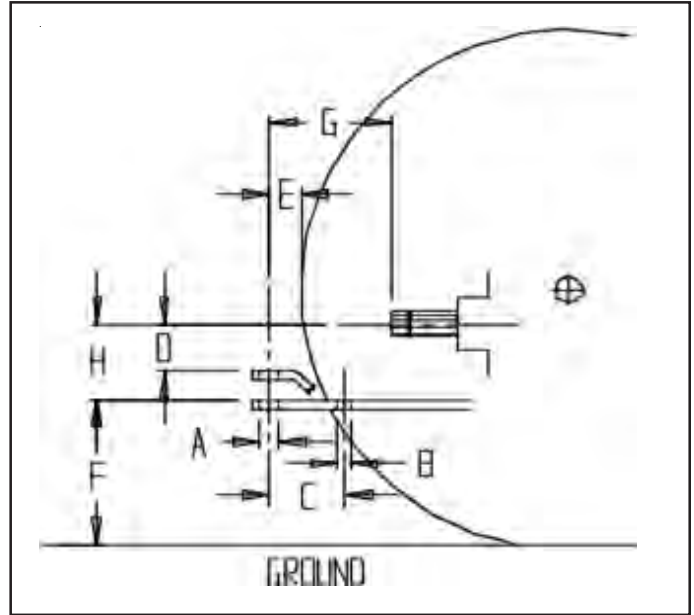

Figure 3. Drawbar — Power Take-Off Standard

TRACTOR DRAWBAR/POWER TAKE-OFF REQUIREMENTS

Tractor must be equipped with drawbar and power take-off that conform to ASAE standards. See Figure 3 (at top right).

For safe power take-off operation, horizontal distance from center of drawbar pin to end of tractor power take-off shaft should be according to Dimension "G" in Figure 3.

To reduce wear on power take-off shaft, universal joints and tractor, power take-off drive shaft should be aligned with blower input shaft. If tractor is equipped with swinging drawbar, adjust so that tractor power take-off and blower drive shaft are in line. See Figure 4.

Nominal Diameter Standard Operating Speed (RPM)	1-3/8" 540 +/- 10	1-3/8" 1000 +/- 25	1-3/4" 1000 +/- 25
A. Hitch pin hole diameter, minimum	1.31"	1.31-1.67"	1.67-2.00"
B. Auxiliary hole diameter	.84"	.84"	.84-1.00"
C. Auxiliary hole spacing	4.0"	4.0"	4.0-5.18"
D. Hitch pin and clevis clearance plane below PTO shaft centerline	7.9-8.8"	7.9-8.8"	8.8-10.0"
E. † Horizontal distance from hitch pin to tire OD: Preferred minimum	1.0"	1.0"	1.0"
F. Height of drawbar with popular tires: 30 - 100 HP 60-170 HP 135-300 HP	13.0-20.0"	15.0-22.0"	15.0-22.0"
G. End of PTO shaft to hitch pin hole	14.0"	16.0"	20.0"
H. Top of drawbar to PTO centerline Minimum Maximum	8.0 12.0	8.0 14.0	10.0 14.0

† Largest code R1 tire specified for use by tractor manufacturer.

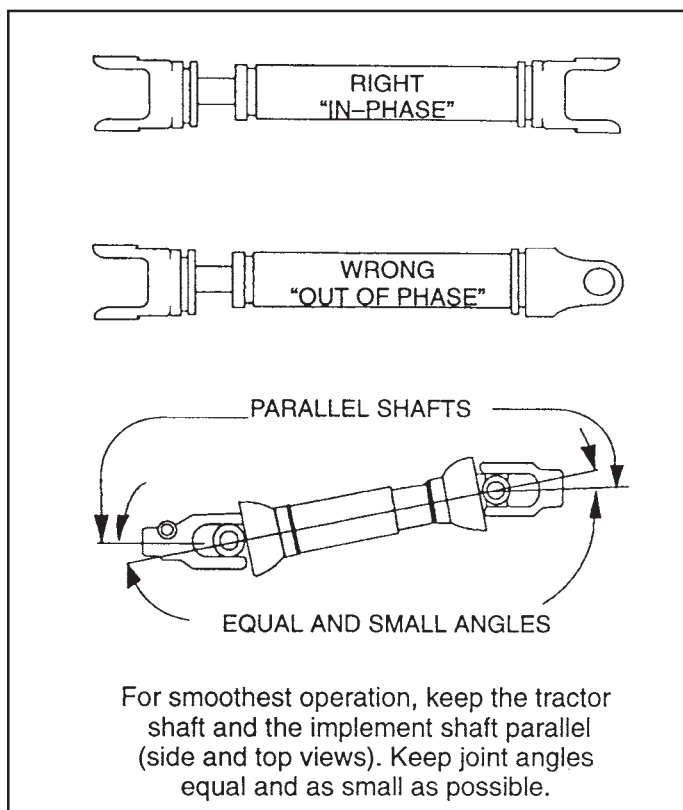

Figure 4. Power Take-Off Operating Angle

Figure 4 shows the correct operating angle for the power take-off.

Check power take-off shaft engagement. With unit attached to your tractor, and without power take-off shaft turning, make sure that the power take-off shaft does not bottom out at the point of most compression of shaft.

Important

Yokes must be kept in proper alignment.

ATTACHING BLOWER TO TRACTOR

Back tractor to Forage Blower, then connect tongue to tractor drawbar. The correct horizontal distance between hitch point and end of the power take-off shaft (Dimension "G") is shown in Figure 3 on page 16.

Shut off the tractor engine and be sure power take-off is disengaged.

Attach blower hitch to tractor drawbar with hitch pin. Be sure to retract jack stand before moving.

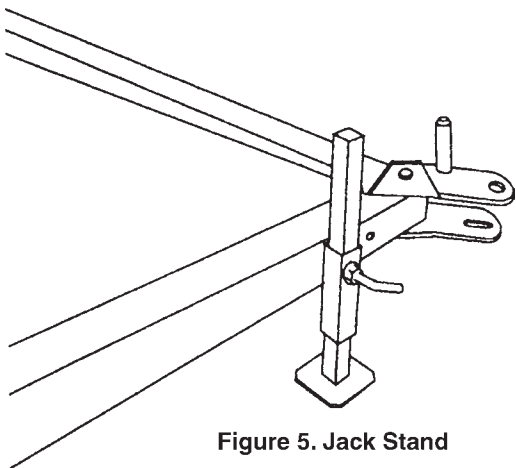

Figure 5. Jack Stand

Note

For best operation, tractor power take-off drive shaft and blower shaft or gearbox shaft must be in line and parallel.

Whenever operating, the Forage Blower must be secured to the tractor drawbar.

Important

If tractor is equipped with a swinging type drawbar, secure it to its center position by pinning on both sides. A swinging drawbar could overload power take-off shaft and cause damage.

TELESCOPIC POWER TAKE-OFF SHAFT ASSEMBLY

Power take-off shaft is attached to tractor's power take-off splined shaft by means of a spring-loaded lock that engages the groove in tractor's splined drive shaft. Be sure lock is fully engaged in groove by firmly pulling shaft rearward.

Be certain that power take-off shaft telescopes freely under hand pressure. Shaft should be not "bottom" in any position. If power take-off assembly does not meet these requirements, repair or replace it and avoid the chances of serious injury.

Follow these precautions to insure safe operation of the power take-off assembly:

1. Power take-off shaft must be in as straight a line as possible.
2. A swinging tractor drawbar must be securely pinned in line with tractor power take-off.
3. Blower hitch must be securely pinned to tractor drawbar.
4. Keep all guards and shields in place on power take-off while operating.
5. Be certain power take-off shaft has free telescopic action and is of proper length.
6. Be sure power take-off shaft is secured to tractor power take-off. Make sure safety lock snaps in place.
7. Disconnect power take-off shaft when transporting Forage Blower. Complete power take-off shaft may be secured to Forage Blower drawbar as shown in Figure 19. Damage to universal joints will occur if Forage Blower is transported with power take-off shaft attached to tractor.

DRIVE OVERLOAD PROTECTION

Most power take-off shaft damage is the result of fluctuating power from tractor. A quick drop and rise of power will create an overload on the power take-off shaft and will not only damage the shaft, but possibly damage the tractor's power take-off system.

Since, in some cases, this surging of power can neither be predicted nor prevented, the power take-off shaft is equipped with a shear bolt assembly. This assembly is designed to break its connecting bolts any time this sudden surge occurs. Shear protection is located at Forage Blower yoke and reduces damage to the power take-off shaft only. However, shear bolts will not protect the tractor's power take-off or blower.

In the event an overload occurs which shears the bolts, disengage power take-off, shut off tractor and determine the cause of shearing. Only specified shear bolts can be used for replacement. Never replace it with a higher or lower strength bolt, as doing so may result in damage to the machine. With power take-off disengaged and tractor shut off, replace shear bolts as follows:

1. Line up holes in both halves of shear hub and drive out existing sheared bolts.
2. Install new shear bolts as shown and tighten to 12 foot pounds. Do not overtighten.

Important 540 RPM PTO

Shear Bolt replacement, use only 5/16" x 2 -1/4" Grade 5 Hex Bolts (Part No. 902603) and 5/16" Hex Lock Nuts. NO SUBSTITUTES.

Important 1000 RPM PTO

Shear Bolt replacement, use only 1/4" x 2" Grade 8 Hex Bolts (Part No. 907336) and 1/4" Lock Nuts. NO SUBSTITUTES.

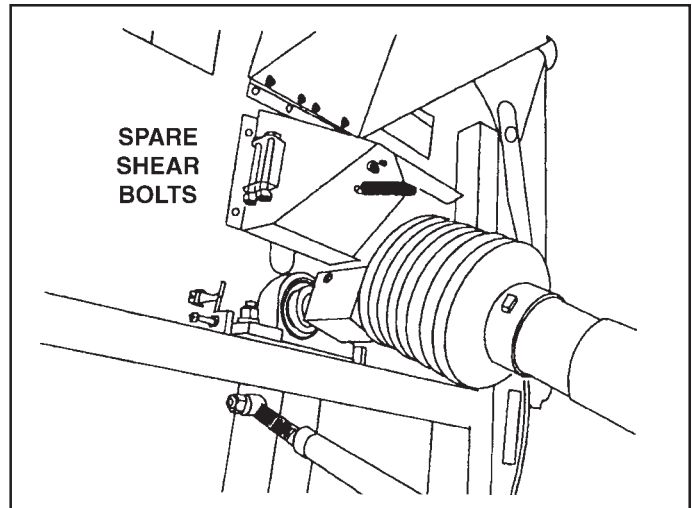

Figure 6. Power Take-Off Shear Hub

ADJUSTING HOPPER HEIGHT

The height of the hopper can be adjusted by turning the wheel adjusting cranks clockwise to raise the hopper or counterclockwise to lower the hopper.

Note

Both wheels are individually adjustable.

Turning the wheel adjusting crank on both wheels counterclockwise to the maximum position will allow frame of the Forage Blower to rest on the ground.

LEVELING THE FORAGE BLOWER

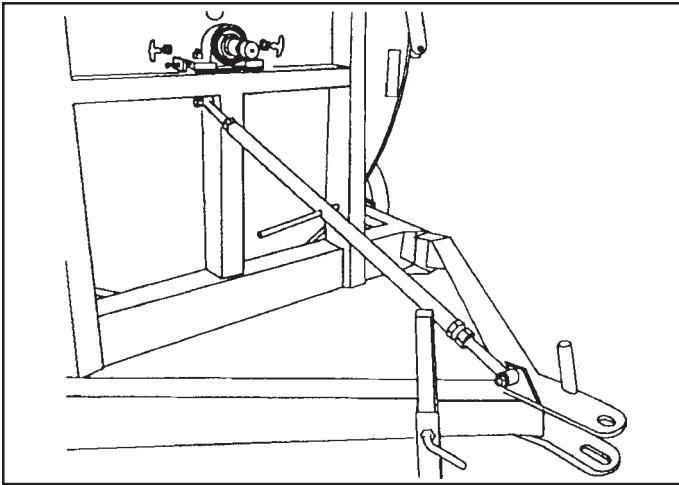

Figure 7. Leveling Fore and Aft

The Forage Blower should be level while operating to ensure good material flow through hopper.

To level the Forage Blower fore or aft, turn adjusting turnbuckle (Figure 7) clockwise or counterclockwise, respectively.

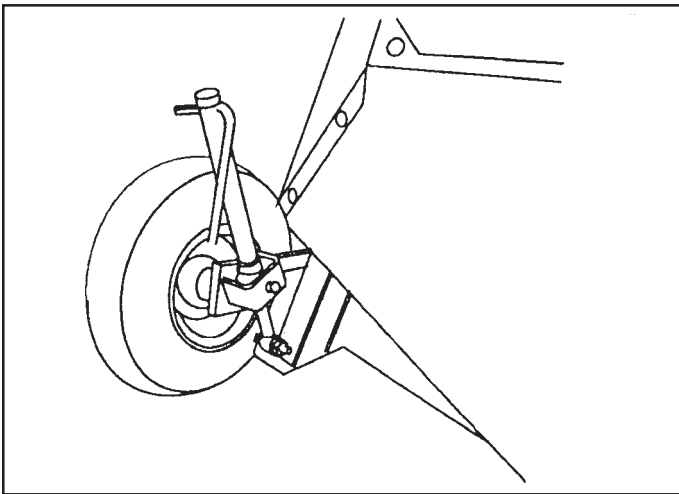

Figure 8. Left Wheel Adjustment

To level the Forage Blower left or right, adjust height of either or both wheel cranks (Figure 8), or trench or block as required.

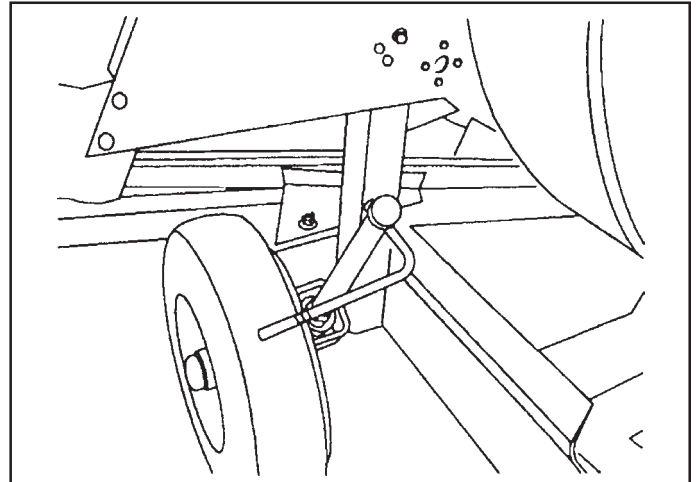

Figure 9. Right Wheel Adjustment

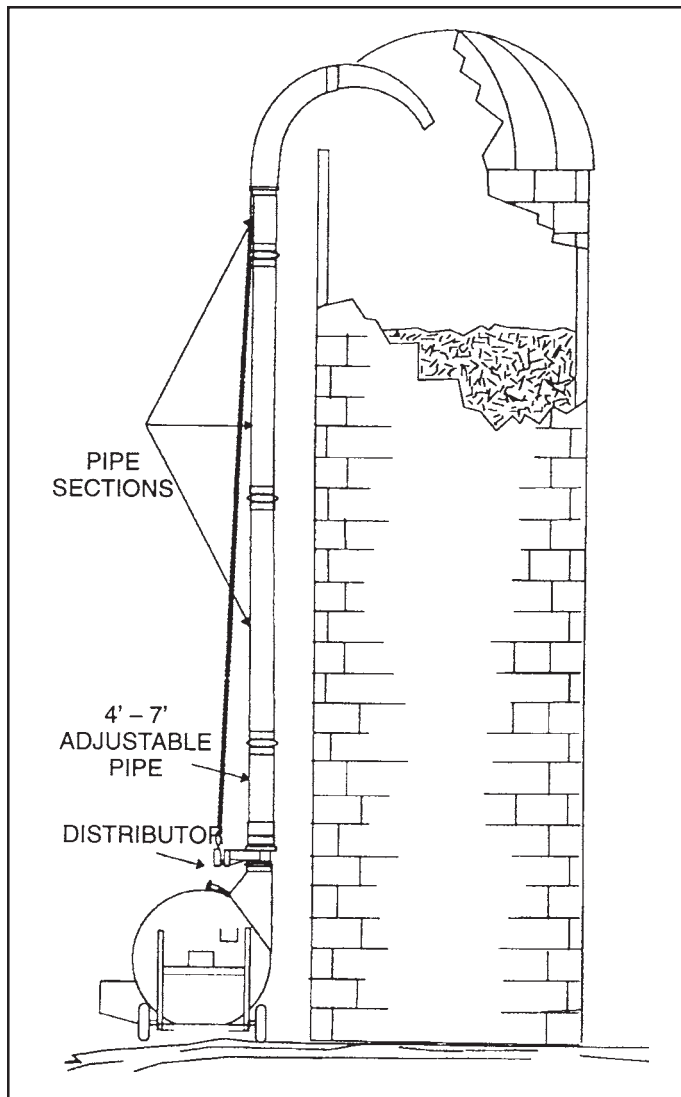

Figure 10. Pipe Assembly

POSITIONING THE FORAGE BLOWER

Position the Forage Blower next to storage facility so that hopper is easily accessible for forage box unloading and in line with Forage Blower pipe. Forage Blower should be level, with drive shaft in a straight line from front to rear with tractor power take-off. Level the Forage Blower so that entry into the blower pipe is a straight line. If necessary, rotate blower band to align it with pipe.

PIPE ASSEMBLY

If use of elbows is necessary, use elbows with large radii and assemble them close to the discharge end of the pipe assembly. Sharp bends and flexible fluttering elbows in the pipe layout will not only cut down capacity, but could cause plugging.

Mount elbow on wall of silo. There should be an 8" to 10" clearance from the bottom edge of the elbow to the top of the silo wall, otherwise back pressure and plugging can occur.

When using telescopic pipe, install right side up. Male end must be mounted on Forage Blower.

Dented or bend pipe must not be used.

Be consistent in pipe diameter sizes. Variations that create ridges or welts will setup turbulence and reduce capacity.

Keep outlet boot vertical for wilted hay or very heavy material.

Running the pipe through the end of a barn is most desirable, since the pipe can be set nearly vertical, and openings are usually available, thereby eliminating the use of elbows. When setting pipe to go through the side of a barn, it is important that the pipe run under eaves and set as close to vertical as possible. Avoid going through roof or roof gables when elbows would be required.

Never let weight of pipe rest on Forage Blower or hang from top of silo only.

Miller accessories are specifically designed for This Forage Blower. Use them, whenever possible.

ACCESS TO OPERATOR AREA

For safe operation of Forage Blower, it is imperative to set up your operation similar to that shown (Figure 11). Walkway clearance between tractors must be maintained for easy access to the operator's area.



CAUTION

Never cross over power take-off or hopper to reach the operator's area. Serious injury or death could result.

Important

Forage Blower must be pinned to the tractor's drawbar during blowing operations.

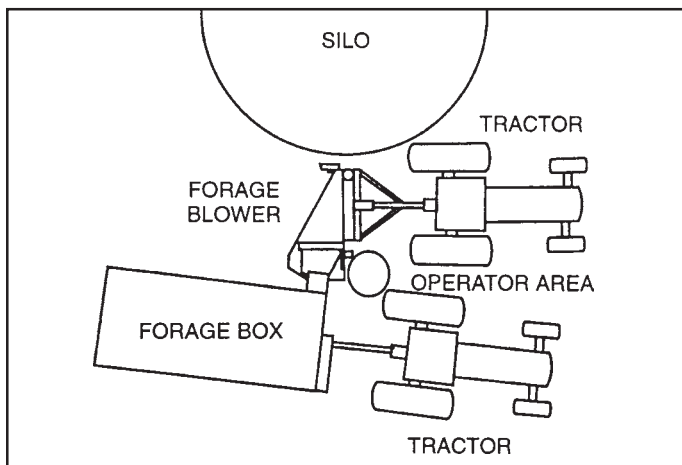

Figure 11. Operator's Path to Controls

ROTATING BLOWER OUTLET

The ranges of pipe angle settings are shown (Figure 12). The vertical position should be used whenever possible for maximum blowing performance. When blowing dry hay at an angle, a reduced tractor throttle setting is recommended to prevent recirculation in lower housing.

The direction of discharge can be changed by rotating blower band and outlet. Measure gap space on blower band (Figure 13). Loosen blower band clamp and rotate blower band to the desired position. After tightening blower band, be sure

grooves along each edge of blower band are firmly seated on side sheets. It may be necessary to tap edges of blower band lightly while tightening to help seat the band properly. Recheck gap space. If greater than prior measurement, clean out grooves to seat band properly. Check and reset shear bar (see Page 31).

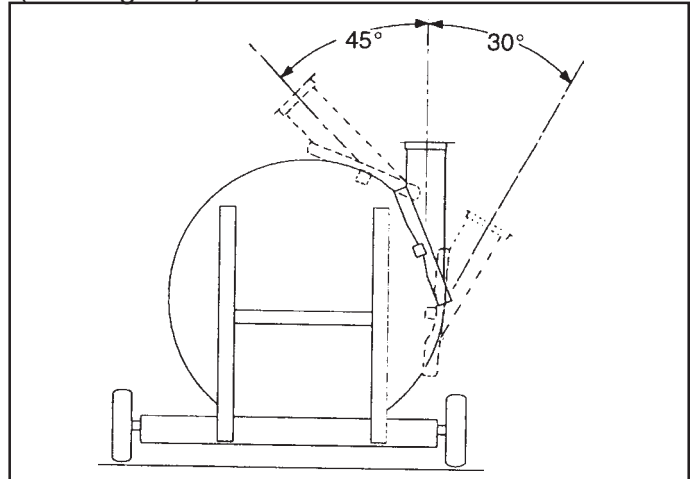

Figure 12. Blower Outlet Range of Settings

Note

It is important that the grooves in the blower band be completely free of foreign material and firmly seated in side sheets. If this is not done paddle tip clearance will be changed and Forage Blower performance will be adversely affected.

Inspection of paddles can be made by removing two bolts at bottom of blower outlet (Figure 13) and swinging outlet up on its top hinge. Outlet may be removed without affecting band tension by taking out hinge pin, if maintenance is necessary.

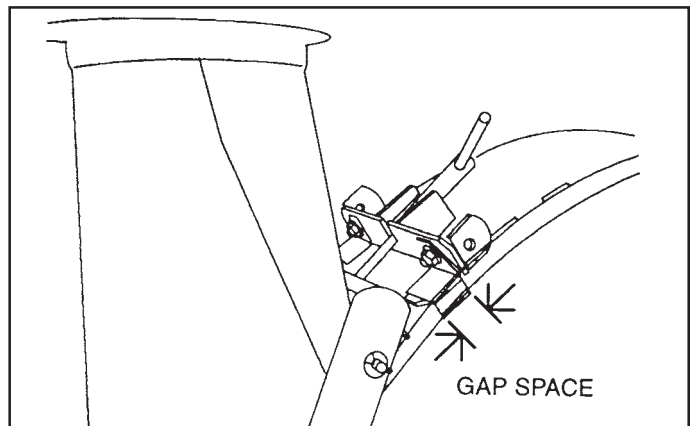

Figure 13. Blower Outlet

OPERATION

CHECKLIST

Before preparing to use Forage Blower, walk completely around machine and observe all CAUTION, WARNING and DANGER decals. These are carefully placed to provide a safe work attitude. Observe them and obey them.



WARNING

Make sure children are kept away and under constant adult supervision and control when ever equipment is in use. Failure to heed may result in personal injury or death.

1. Tractor condition.
 - a. Continuity of power.
 - b. 540 RPM or 1000 RPM with optional gearbox.
 - c. Stability.
2. Forage Blower stability.
 - a. Machine level.
 - b. Jack stand raised and secured in place.
 - c. Secured and hitched to tractor.
3. Shear bolt assembly.
 - a. Remove shear bolts and check shear flanges to insure they are free of rust. Lubricate flanges and reassemble.
 - b. Shear bolts snug, but not tight.
4. Power take-off alignment.
 - a. Tractor/blower shafts parallel.
 - b. Equal yoke angles.
5. Fan clearances.
 - a. Rotate by hand.
 - b. Fan properly adjusted.
6. Blower band properly tightened.
7. Shear bar properly adjusted.
8. Auger control lever disengaged.
9. Outlet boot and pipe flanges properly mated.
10. Pipe assembly straight and properly supported.
11. Optional 1000 RPM gearbox oil level proper.

When checklist has been completed and pipe assembly has been properly set up, Forage Blower is ready for operation.

STARTING

Start with a low tractor throttle setting and engage power take-off drive. Gradually work up to recommended RPM speed and begin feeding operation. By starting Forage Blower slowly, you will alleviate a sudden jolt to the power take-off shaft and the shear bolts.

BLOWER FAN SPEED

The Forage Blower is designed to operate at a power take-off speed of 540 RPM or 1000 RPM with optional gearbox, under load. With shelled corn, reducing the RPM 30% - 50% is normally recommended. Tractor power, type of crop, moisture content, and condition of pipe will affect capacity and operating heights.

AUGER CONTROL

Engage auger by pushing auger control lever (Figure 14) away from forage box.

Engage control lever on self-unloading box and regulate flow so that ensilage moves without excess spillage.

Important

DO NOT feed ensilage into hopper of Forage Blower until power take-off is operating at recommended RPM.

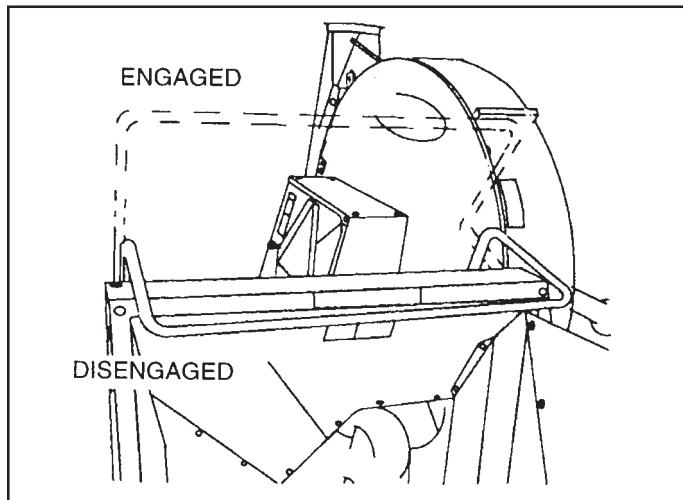

Figure 14. Auger Control Lever Position

DURING OPERATION

Feed material as far forward into hopper as possible. Material entering on top of auger is desirable as this will feed material directly into fan. Keep a steady continuous flow of material going into hopper.

While Forage Blower is operating, periodically check RPM for proper speed. Between loads, check for gumming on fan or blower housing.

If Forage Blower becomes plugged or hopper becomes overloaded, disengage auger and halt flow of silage into hopper. If shear bolts shear, immediately disengage auger clutch, halt flow of silage into hopper, and disengage blower drive power take-off. Replace shear bolts only after fan has stopped turning.

Important

It will be necessary to re-tighten band after every load for first ten loads, and daily during the first few days of operation, or after having made a band adjustment or replacement.

ADDING WATER

At times when moisture content in some crops reaches 40 to 60 percent, they will release some very sticky plant juices. These juices will cause a gum deposit on any surface that the crop comes in contact with. A gum buildup inside the blower housing or pipe will definitely reduce the blowing efficiency of the Forage Blower. A ticking noise while operating may result from the paddle tips striking a very heavy gum buildup inside blower housing.

To remove or prevent plant gum buildup, attach a water hose with shutoff valve to flange (Figure 15) provided in hopper and inject a spray of water into hopper with crop. Use enough water to keep inside of the blower housing and fan free of gum buildup.

ADDING WATER, continued

Your Forage Blower may be equipped with a secondary water coupling (Figure 15) attached to the blower band. This location can be used for adding water to prevent gum buildup inside blower. Although it is available it is not the preferred location for adding water.

To use this coupling drill a 1/4 inch hole into the band and attach a water hose with shutoff to inject water into the blower housing.

Note

Surfaces can be checked between loads, after making sure tractor is shut off and Forage Blower has completely stopped turning.

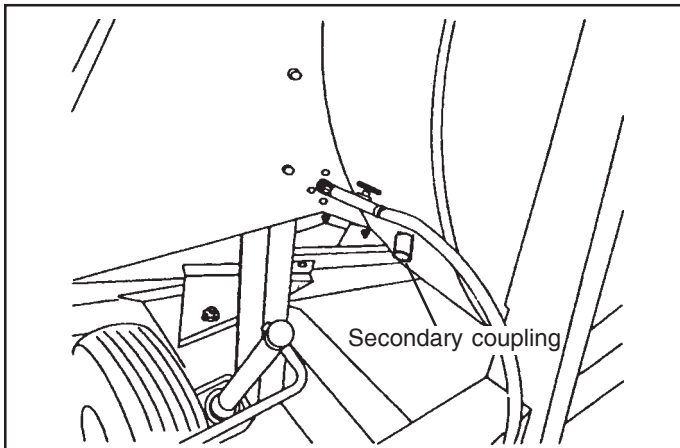

Figure 15. Water Inlet Connection

To reduce friction heat when blowing an excessively dry crop, water can be added.

An increase in crop moisture content due to this addition of water is very small. For example, if a total of 5 gallons of water is added while blowing a 4 ton load of a 50 percent moisture crop, the increase in average moisture content will be only 1/4 of one percent.

Begin feeding crop into hopper before turning water on and turn water off before unloading of box is complete. Plugging of pipe can occur if water enters before crop.

While water is generally added for removing plant gum, it has been found that water can also be added to improve blowing performance when working with a difficult crop, even though there are no visible gum deposits.

AIR CONTROL BAFFLE

When blowing shelled or ground ear corn, high back pressure in blower pipe may cause some crop to discharge out transition air inlet. If this happens, close the air inlet by sliding the baffle cover down to cover the air inlet slot. (Figure 16).

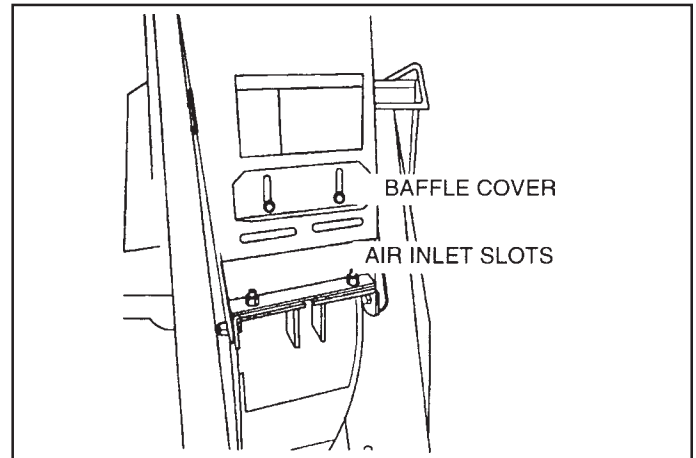

Figure 16. Air Control Baffle

SHUTDOWN OF BLOWER

Shut off water, if being used, and disengage auger control lever (Figure 14). Shut down Forage Blower as gradually as it was started by reducing power take-off RPM.

UNPLUGGING OF BLOWER OR PIPES



WARNING

DO NOT perform any unplugging or pipe removal on this machine unless the POWER SOURCE SHUTDOWN PROCEDURE (page 10) has been exercised.

If the blower pipes or blower become plugged use care when removing pipes from blower to avoid crop from falling from the pipe and into your face.

DO NOT remove crop through the blower throat. Blower fan could move unexpectedly pinching hands or fingers. Always remove the throat to remove crop.

DO NOT operate blower unless the blower pipes are securely attached to blower.

TRANSPORTING AND STORAGE

HIGHWAY SAFETY CHAIN

When transporting Forage Blower on a public highway, a highway safety chain must be used (Part No. 322580B91) (Figure 17). Check state and local codes before towing on a public road. Do not tow at speeds in excess of 20 MPH.

In addition to a highway safety chain, a safety hitch pin is recommended.

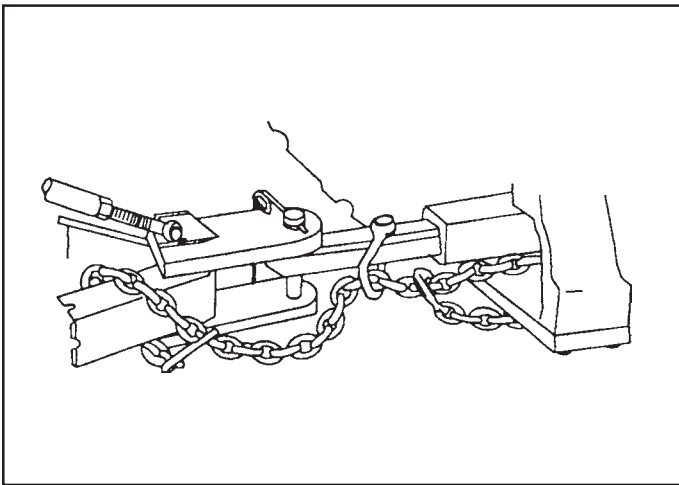

Figure 17. Highway Safety Chain

After attaching a highway safety chain, make a trial run by driving the tractor to the right and to the left for a short distance to check highway safety chain adjustment. If necessary, readjust to eliminate excessive chain tightness or looseness.

TRANSPORTING BLOWER

DO NOT tow Forage Blower at speeds in excess of 20 MPH.

When transporting Forage Blower, turn both wheel adjusting cranks (Figure 18) to their maximum clockwise position. This provides for maximum ground clearance.

Also, Forage Blower should be tilted slightly forward (toward towing vehicle) for transport. This is done by turning hitch adjusting turnbuckle clockwise.

Drive at a reasonable speed not to exceed 20 MPH to maintain complete control of Forage Blower at all times.

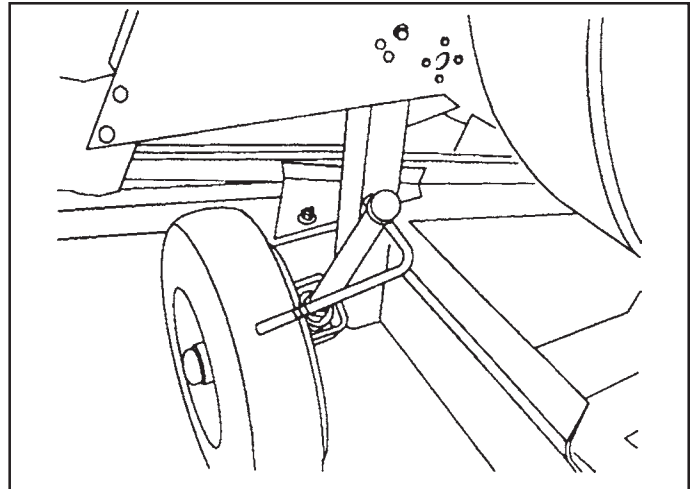

Figure 18. Wheel Crank

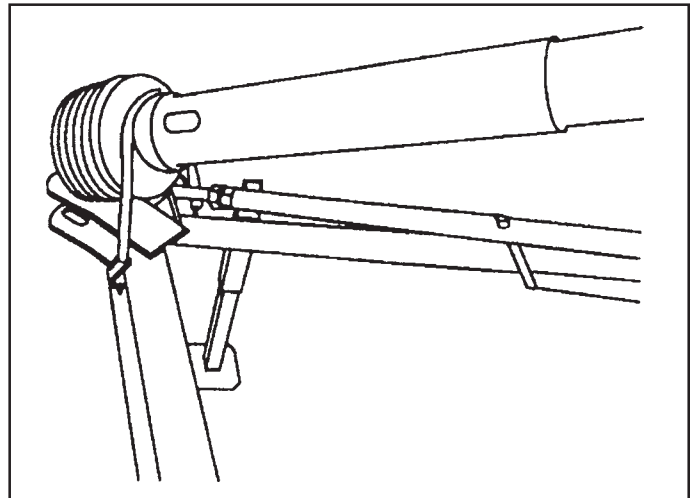

Figure 19. Power Take-Off Transport Position

Important

When transporting Forage Blower on a road or highway, always display an SMV (Slow Moving Vehicle) Emblem. At night, use accessory warning lights as required by government regulations. Maximum towing speed is 20 MPH.

STORAGE INSTRUCTIONS

Remove all dirt and ensilage that may be on or in Blower.

Grease as outlined in "Lubrication" section.

Disengage auger control.

Re-paint areas when worn. Apply a coat of rust inhibitor or light lubricant to the fan housing and the blower band.

Replace worn parts with authorized Miller parts specially designed for Miller Forage Blowers.

Store Forage Blower in a dry place, or protect with a cover if left in the open, and protect it from weather and livestock.

ADJUSTMENTS



WARNING

DO NOT perform any adjustments on this machine unless the POWER SOURCE SHUTDOWN PROCEDURE (page 10) has been exercised.

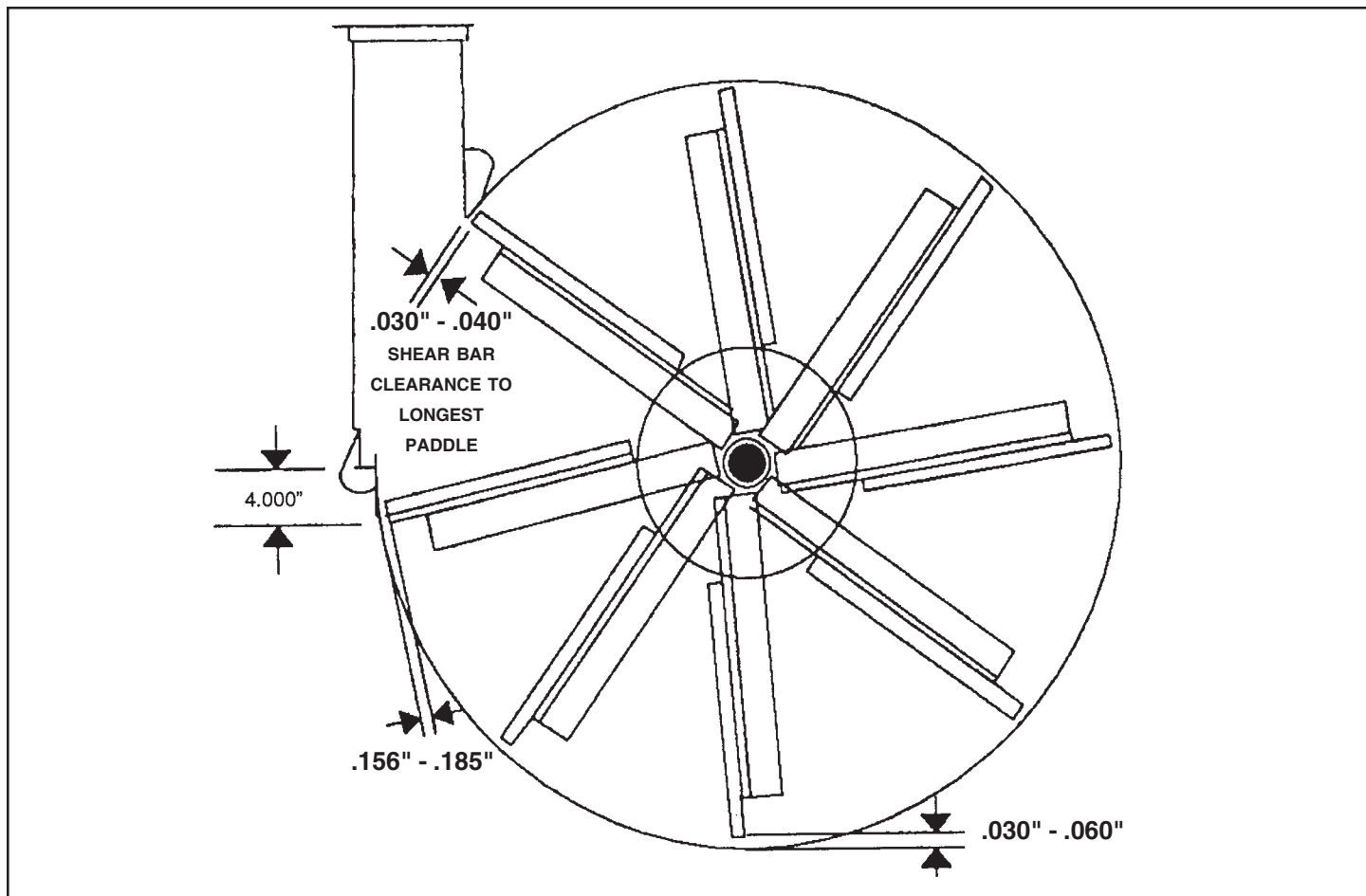

Figure 20. Adjustment Check Points

CHECK FAN TIP CLEARANCE



CAUTION

Be sure power take-off is disconnected before checking or adjusting fan paddle clearance.

Refer to Figure 20.

Fan adjustment is made by adding or removing shims (Figure 21) under fan shaft bearings. This adjustment moves fan up and down. Adjustment is also made with set screws at both front and hopper side of fan housing. This adjustment moves fan assembly from side to side.

1. Blower band must be properly tightened before checking or making any adjustments.
2. Clean inside of fan housing, shown in Figure 20, and paddle tips.
3. Check all paddle tips for proper length. Adjust shear bar down snug and square against tip of longest paddle. Loosen paddle bolts and adjust short paddles up square and snug to shear bar, not to exceed .015 clearance. See page 30, paddle replacement for proper bolt torque. Readjust shear bar, see shear bar adjustment on page 31.
4. With a feeler gauge, measure across full width of paddle to make sure paddle tips are square with blower band.

FAN PADDLE

Forage Blower sides must be fully seated into grooves of blower band while gauging or adjusting paddle clearance. If Forage Blower has been used, disassemble blower band from Forage Blower, remove all material deposit from the grooves and reinstall band.

All paddles must be the same length. Adjust as required. See "Paddle Replacement".

The correct clearance dimensions and gauging locations are shown in Figure 22 (Paddle Clearance). Clearance at "A" can be checked from hopper inlet. Clearance at "B" can be checked by opening blower outlet. Determine the longest paddle and measure clearance at both locations.

PADDLE CLEARANCE

To adjust paddle clearance, loosen the two fan bearing mounting bolts (Figure 23) on each bearing. Check clearance at "A" at bottom of Forage Blower. This clearance must be between .030" and .060". Adjust if necessary by adding or removing shims located under fan shaft bearings. Shims must be added or removed from under both bearings as required.

The clearance at "B" must be between .156" and .186" inch. This is measured at "B", 4" below the end of the blower band. This clearance must always be greater than the clearance at "A".

Adjust by moving bearings sideways. Loosen jam nuts and turn adjusting screws. Adjust both bearings to maintain uniform clearance between side sheet and fan paddles.

Clearance between paddles and feed entry sheet must be set at 1.00-1.06" at rear from A to B. Adjust by adding or removing shims inside both main bearings as needed. The blower will operate most efficiently at this setting. To fill taller silos with material similar to corn silage reducing this clearance to .937 will improve blowing height. At this setting the blower will demand more power.

After adjustments are made, torque fan bearing mounting bolts (Figure 23) to 80 to 90 foot pounds. Recheck paddle clearance at "B" and "A".

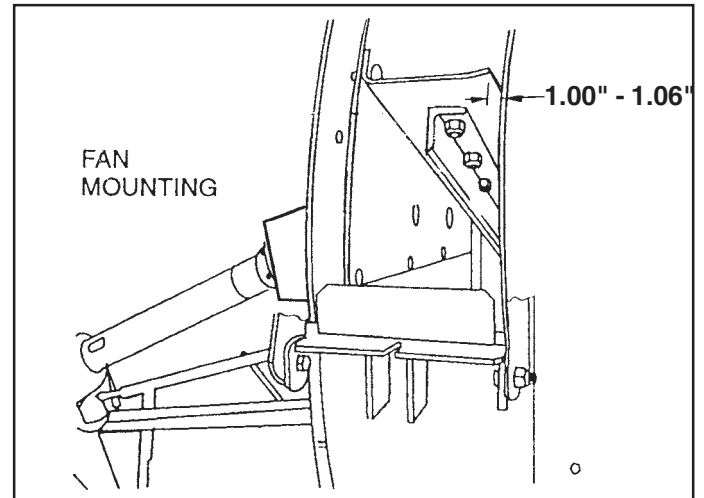

Figure 21. Fan Adjustments

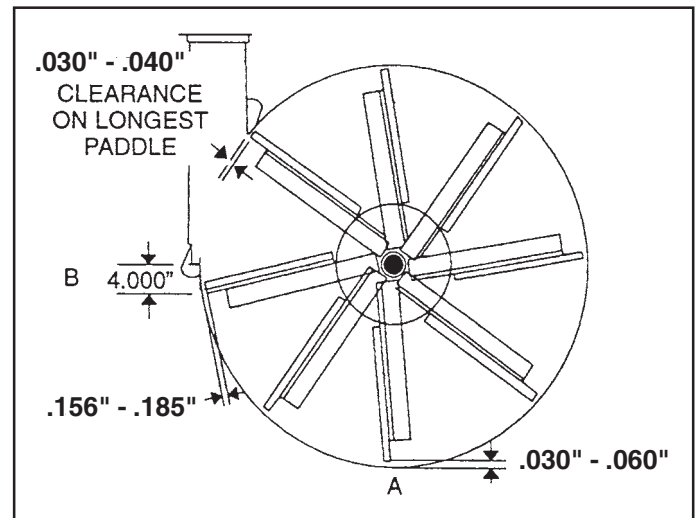

Figure 22. Paddle Clearances

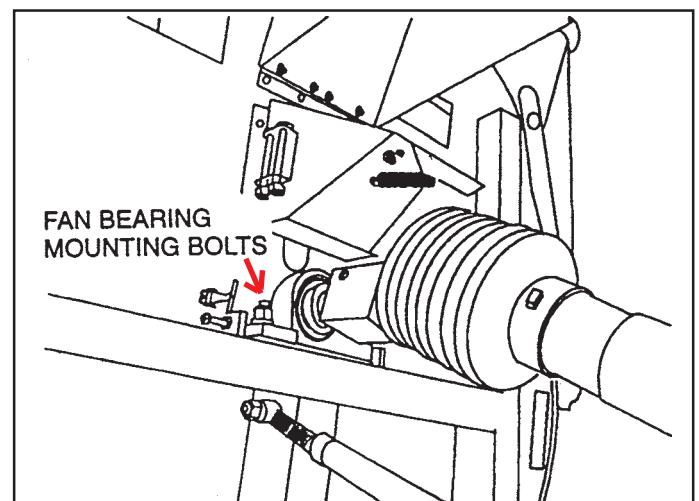

Figure 23. Blower Bearing

PADDLE REPLACEMENT

To replace a paddle, remove outlet boot and adjust shear bar down snug and square against tip of longest paddle. Remove carriage bolts holding paddle to arm and back sheet. Bolt a new paddle in place and adjust it up square and snug to shear bar. Torque bolts holding paddle to arm to between 140 and 160 foot pounds. Torque bolts holding back sheet to paddle to between 70 and 80 foot pounds.

After replacing paddles check and adjust paddle to band and housing clearances. See "Paddle Clearance". Adjust shear bar to paddle tip clearance. See "Shear Bar Adjustment".

When replacing three or more paddles on fan at one time follow the procedure described above.

Important

For optimum performance, tip clearance for each paddle must be the same.

HOUSING BAND

Blower band is reversible. If damage or excessive wear occurs in the area between the hopper inlet "A" and transition opening "B", remove band, externally repair damaged area, and reinstall band with repaired area on top side of blower housing.

Loosening band tightener (Figure 24) relieves tension on blower band and allows it and outlet boot to be placed in various positions to direct flow of material as desired.

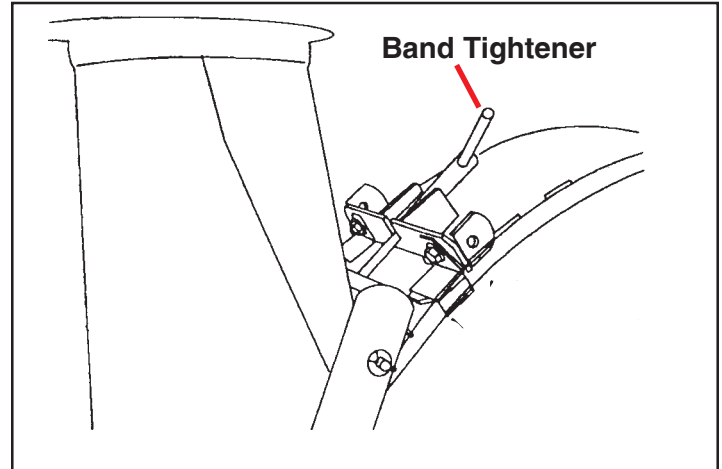

Figure 24. Band Adjustment

Important

Fan tip and shear bar clearance **MUST** be readjusted whenever outlet boot is repositioned.

When tightening, be sure that Forage Blower sides are firmly seated in band grooves. Firm hand tightening is sufficient.

Important

NEVER operate Forage Blower with a loose band. Band must be kept tight at all times. Operating with a loose band will result in premature band failure and band cracking.

An extreme low angle setting on the outlet boot may reduce capacity when blowing some heavier materials or wilted hay.

CAUTION

Never attempt to reposition band with pipes attached or Forage Blower in operation!

SHEAR BAR ADJUSTMENT

The shear bar (Figure 25) eliminates forage binding between fan blade tips and blower band. It also prevents power loss, plugging, and material carryover.

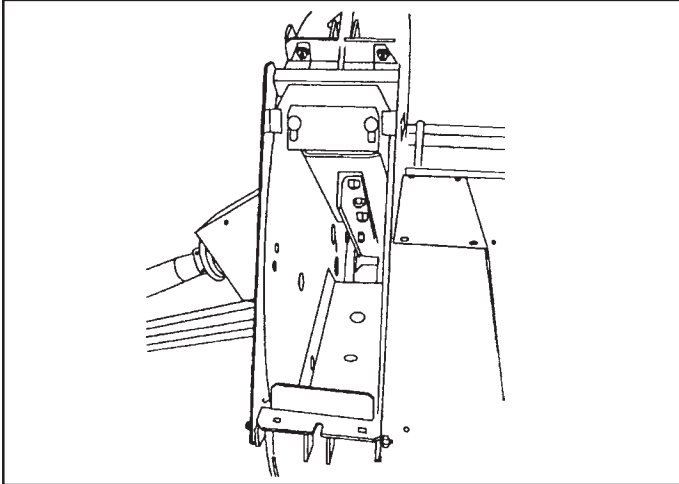

Figure 25. Material Shear Bar

Adjustment or replacement of shear bar is done with outlet boot removed. To adjust shear bar, loosen bolts and adjust shear bar (bevel down) so that there is a .030" - .040" clearance between it and tips of fan blades. Tighten bolts securely when adjustment is completed.

Turn fan shaft by hand after making any adjustments to insure the fan blades clear shear bar.

Important

Check the shear bar adjustment whenever band and outlet boot position is changed.



CAUTION

Keep hands out of blower outlet while rotating fan.

AUGER DRIVE BELTS

BELT TENSION-DRIVE SHAFT

Tension of auger drive shaft belt (Figure 26), is changed by increasing or decreasing tension on spring on idler arm. To increase belt tension, loosen lock nut and turn adjusting nut clockwise. To decrease tension, turn adjusting nut counter-clockwise. A spring with a hook-to-hook measurement of 6-11/16" will give proper tension. After adjusting, tighten lock nut.

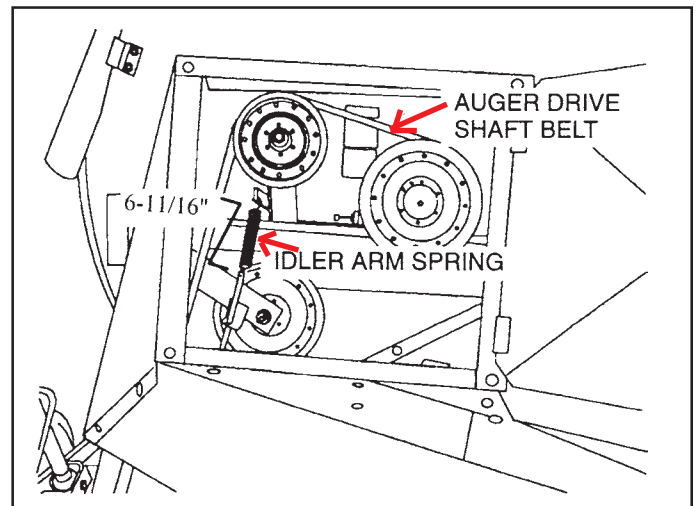

Figure 26. Auger Drive Shaft Belt Adjustment

BELT TENSION-AUGER DRIVE

Tension of auger drive belt is changed by adjusting clutch compression or yoke (Figure 27). Remove pin. Turn yoke clockwise to decrease tension and counterclockwise to increase tension.

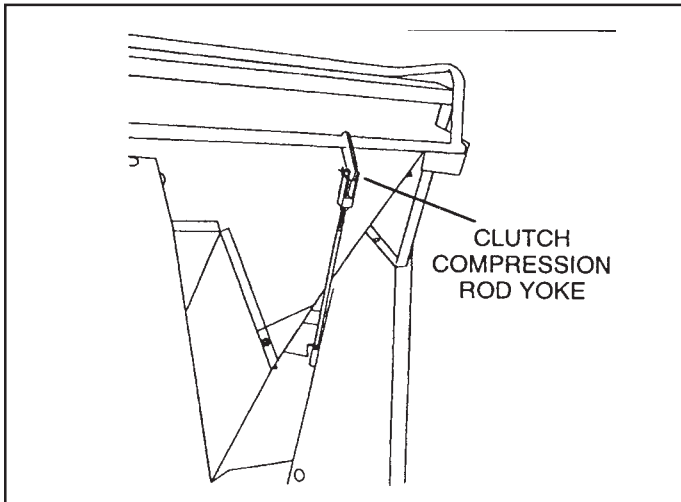

Figure 27. Auger Drive Belt Adjustment

Auger drive belt is properly tensioned when a force of 10 to 15 pounds is needed to pull handle into disengaged position.

BELT REPLACEMENT

To replace auger drive shaft belt (Figure 26), remove tension from idler arm, remove old belt and replace with new. Re-adjust belt tension as detailed under "BELT TENSION - DRIVE SHAFT".

To replace auger drive belt, disengage auger to relieve tension on belt. Remove outer bearing nuts (Figure 28) and bearing support plate. Remove old belt and replace with new. Replace support plate and bearing nuts. Re-adjust belt tension as shown under "BELT TENSION - AUGER DRIVE".

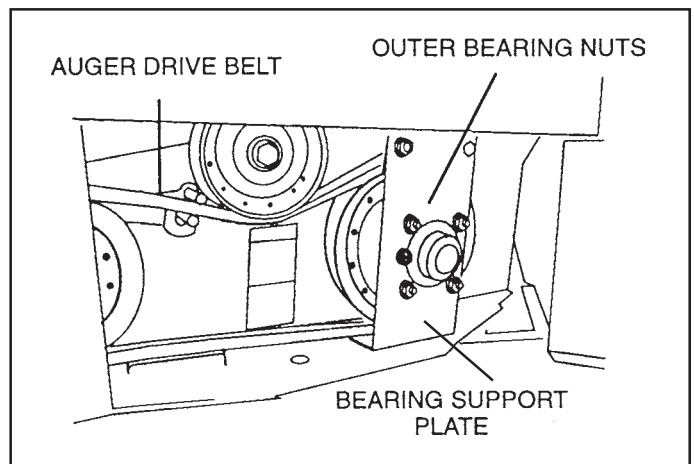

Figure 28. Replacing Auger Drive Belt

Note

After replacing auger drive belt, check auger clearance. Refer to instructions under "AUGER CLEARANCE". This should be done while re-tightening auger bearings and support plate bolts.

AUGER CLEARANCE

Should it become necessary to adjust auger clearance, slightly loosen the eight auger bearing mounting bolts (Figure 29) and adjust auger to run parallel with trough bottom and parallel with stripper along right side of auger. These measurements are made from the auger bearing end of auger to one auger flight back from end of auger.

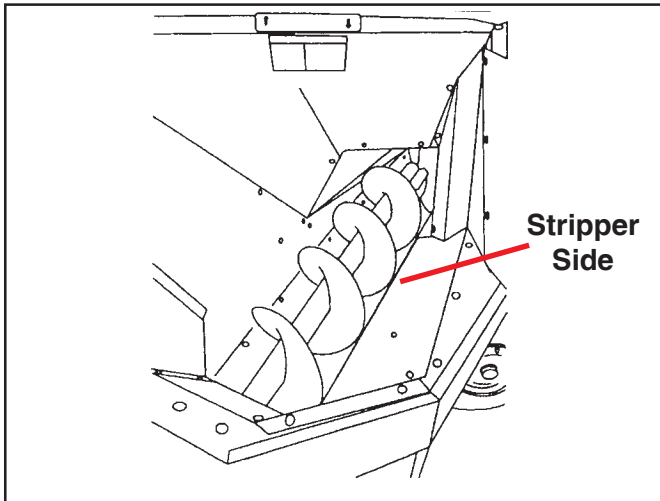

Figure 29. Adjusting Auger Clearance

Re-tighten bearing mounting bolts after adjustment is made.

GENERAL

Due to the flammable nature of crop materials encountered by hay harvesting machines, fire risks are high. This risk can be minimized by frequent removal of accumulated crop material from Forage Blower (and tractor), and by checking for overheated machine components. Be sure to stop Forage Blower and shut off engine before this is done.

SHEAR BOLTS

The Forage Blower's main drive is protected against shock or overloads by shear bolts (Figure 30). If these bolts shear, determine and correct the cause for shearing before replacing the shear bolts.



CAUTION

Make certain the power source is off and the machine is stopped before inspecting or servicing shear bolts.

To replace shear bolts (Figure 30), first remove remaining pieces of sheared bolts, if any. Align holes in yoke and flange and replace sheared bolts with bolts for a 540 or 1000 RPM PTO (see page 19 for proper bolts). When replacing bolts see LUBRICATION section under Shear Device.

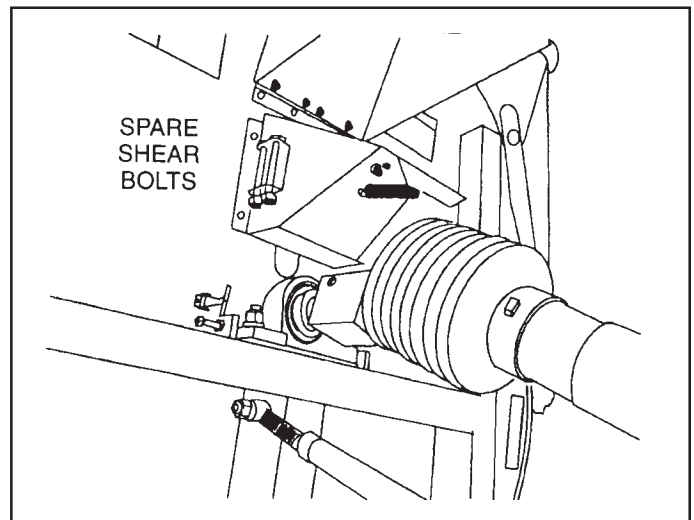

Figure 30. Shear Bolt Replacement

LUBRICATION AND MAINTENANCE



WARNING

DO NOT perform any lubrication or maintenance on this machine unless the **POWER SOURCE SHUTDOWN PROCEDURE** (page 10) has been exercised.

POWER TAKE-OFF

The power take-off cross and bearings should be greased twice a day for the first two days of operation and once each day thereafter, using a good grade of grease. (See Figures 31, 32 & 33).

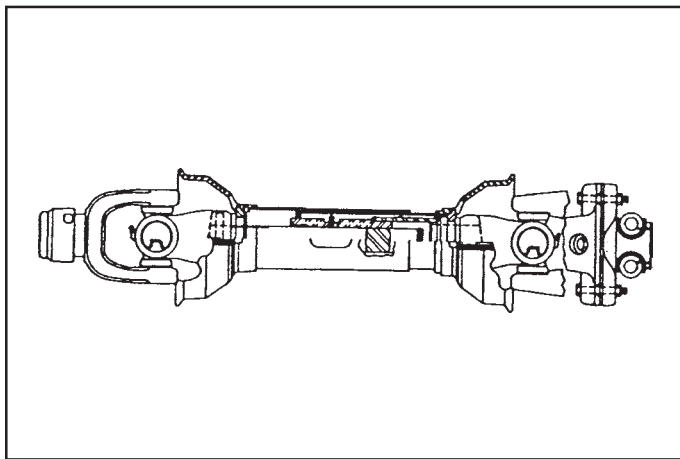

Figure 31. Power Take-Off Tractor End

PILLOW BLOCK BEARINGS

The two pillow block bearings of fan shaft should be greased every 30 hours of operation or twice a wheel whichever occurs first. (See Figures 32 and 33).

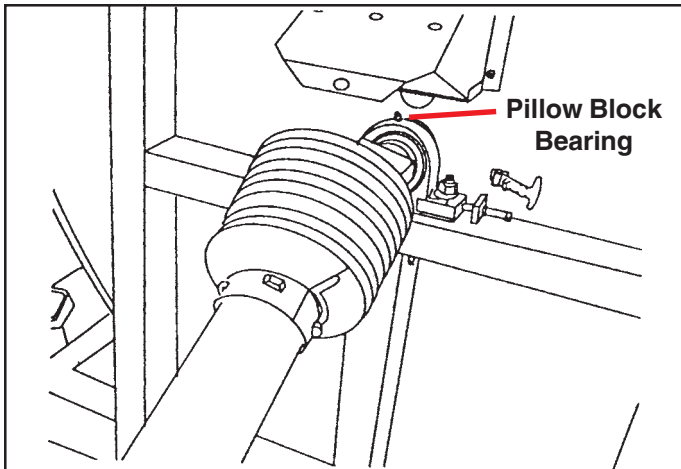

Figure 32. Front Fan Bearing

The power take-off is also equipped with a grease fitting for lubricating the telescoping sections, and should be greased before each season's use. (See Figure 33).

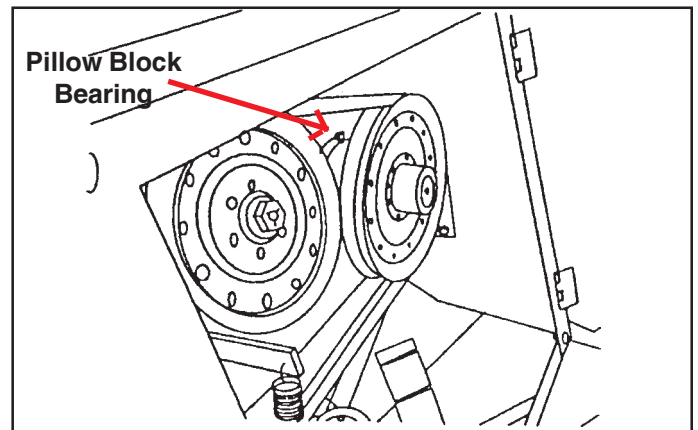

Figure 33. Rear Fan Bearing

SHEAR DEVICE

Lube: start of season and when replacing bolts.

AUGER BEARINGS

The two flange bearings on auger shaft should be greased every 30 hours of operation or twice a week whichever occurs first.

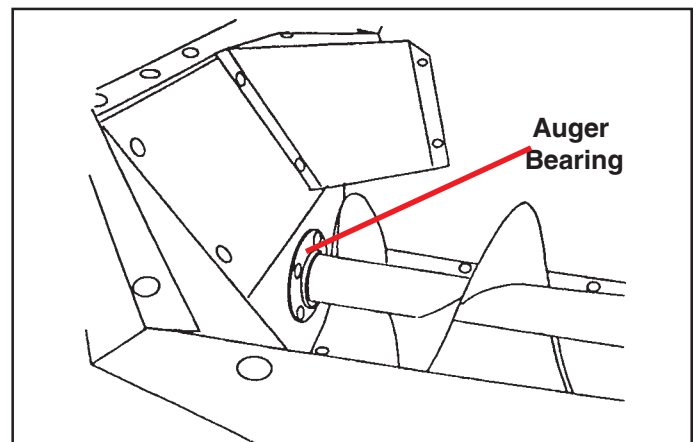

Figure 34. Auger Bearings

AUGER DRIVE SHAFT

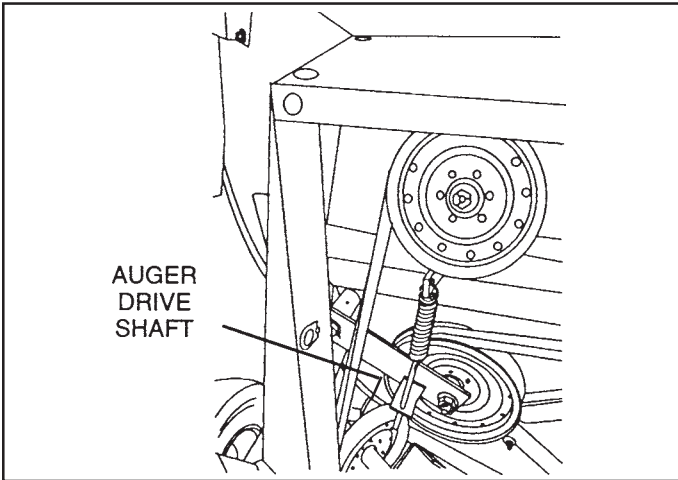

Figure 35. Auger Drive Shaft

The two flange bearings on auger drive shaft should be greased every 30 hours of operation or twice a week whichever occurs first (see Figure 35).

CLUTCH LINKAGE

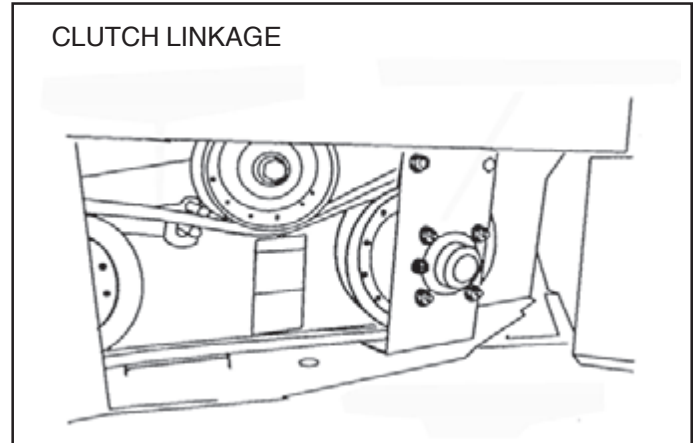

Figure 37. Clutch Linkage

Before each season's use, and before storing, oil the pivot points in the clutch linkage (See Figure 37).

IDLER PIVOT

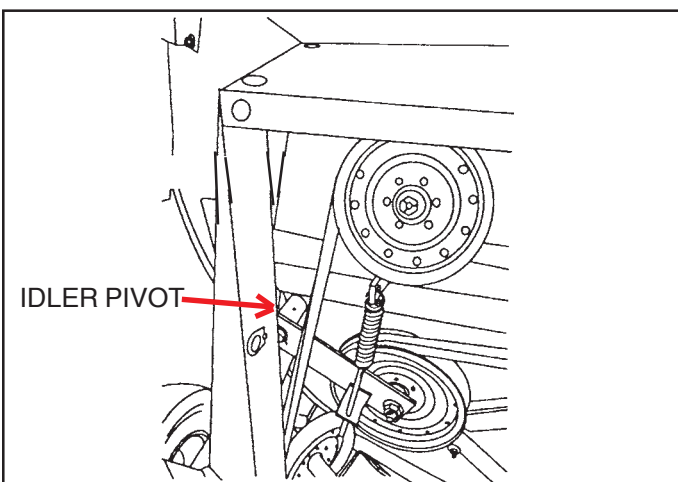

Figure 36. Idler Pivot

Before each season's use, and before storing, oil the idle pivot (See Figure 36).

WHEELS

At the beginning of each season, or if the Forage Blower is to be transported, remove wheel bearings. Clean and repack them with a good grade of wheel bearing grease.







1000 RPM GEARBOX

Fill to oil level plug located 2.5" left of center and 5" from bottom of gearbox. Use only 6 EP synthetic gear lube, Part No. 335395B91, no substitutions.

TORQUE SPECIFICATIONS

NOTE: Use these torque values when tightening hardware (excluding: locknuts and self-tapping, thread forming and sheet metal screw) unless specified otherwise.

All torque values are in lb-ft except those marked with an * which are lb-in (for metric torque value NM, multiply lb-ft value by 1.355 or lb-in value by 0.113).

Unified National Thread	Grade 2 		Grade 5 		Grade 8 	
	Dry	Lubed	Dry	Lubed	Dry	Lubed
8-32	19*	14*	30*	22*	41*	31*
8-36	20*	15*	31*	23*	43*	32*
10-24	27*	21*	43*	32*	60*	45*
10-32	31*	23*	49*	36*	68*	51*
1/4-20	66*	50*	9	75*	12	9
1/4-28	76*	56*	10	86*	14	10
5/16-18	11	9	17	13	25	18
5/16-24	12	9	19	14	25	20
3/8-16	20	15	30	23	45	35
3/8-24	23	17	35	25	50	35
7/16-14	32	24	50	35	70	55
7/16-20	36	27	55	40	80	60
1/2-13	50	35	75	55	110	80
1/2-20	55	40	90	65	120	90
9/16-12	70	55	110	80	150	110
9/16-18	80	60	120	90	170	130
5/8-11	100	75	150	110	220	170
5/8-18	110	85	180	130	240	180
3/4-10	175	130	260	200	380	280
3/4-16	200	150	300	220	420	320
7/8-9	170	125	430	320	600	460
7/8-14	180	140	470	360	660	500
1-8	250	190	640	480	900	680
1-14	270	210	710	530	1000	740
Metric Course Thread	Grade 8.8 		Grade 10.9 		Grade 12.9 	
	Dry	Lubed	Dry	Lubed	Dry	Lubed
M6-1	8	6	11	8	13.5	10
M8-1.25	19	14	27	20	32.5	24
M10-1.5	37.5	28	53	39	64	47
M12-1.75	65	48	91.5	67.5	111.5	82
M14-2	103.5	76.5	145.5	108	176.5	131
M16-2	158.5	117.5	223.5	165.5	271	200

TROUBLESHOOTING

The most common problems usually arise from a faulty tractor, an improper pipe setting or use of an accessory other than one designed for the Forage Blower. Since these problems are easily remedied,

check them and the problems listed below first. If none of the suggested remedies solve your problem, contact your dealer. He will be glad to serve you.

PROBLEM	PROBABLE CAUSE	SUGGESTED REMEDY
Pipe Plugged	Tractor RPM too slow	Increase tractor to proper RPM. (540)
	Telescoping pipe or welts in pipe assembly.	Reassemble telescoping pipe so that small end feeds into large end.
	Gumming occurs in fan housing or pipe assembly.	Flush Forage Blower, then use water inlet while blowing material.
	Fluctuating tractor RPM.	Check tractor for constant operating RPM.
	Use of varied pipe sizes.	Be consistent in pipe diameter.
	Dented or bent pipes.	Replace damaged pipes.
	Improperly positioned fan in housing.	Readjust to fan, paddle tip and feed entry side clearance instructions.
Excessive shearing of shear bolts.	Fluctuation tractor speed.	Check tractor's overall condition. (i.e. ignition, governor, power take-off, etc.)
	Shear bar out of adjustment.	Readjust to shear bar to instructions.
	Use of improper type or size shear bolt.	Replace with correct shear bolt.
	Fan set too far forward.	Set fan to fan paddle instructions.
	Starting blower at too high a tractor RPM.	Reduce tractor RPM before engaging power take-off.
	Water in blower housing.	Turn water off before shutting down.
Power take-off breakage.	Fluctuating tractor RPM.	Check tractor's overall condition. (i.e. ignition, governor, power take-off, etc.)
	Power take-off shaft is out of alignment	Put power take-off shaft on as straight a line as possible, both vertical and horizontal.
	Shear bolts are too tight.	Tighten shear bolts to 12 ft/lbs. Do not overtighten.
Fan strikes housing.	Improper clearance.	Set fan to fan paddle instructions.
Blower band cracking.	Operating blower with loose band.	Replace band and keep band tight.
	Shear bar out of adjustment.	Adjust shear bar to .030"-.040" setting.
Power Loss	Fan tip clearance.	Adjust to paddle clearance instructions.
	Shear bar clearance.	Adjust to shear bar clearance instructions.
	Excessive paddle tip wear.	Replace all paddles.
Auger Drive Belt Failure	Belt stretch and wear.	Adjust drive belt clutch tension.
		Adjust auger drive belt spring tension.
	Improper auger alignment	Adjust auger clearance per instructions.

SPECIFICATIONS

		540 RPM	1000 RPM
<u>TRACTOR</u>	Horsepower PTO Speed	140 Min 540 Max	140 Min 1000 RPM Max
<u>POWER TAKE-OFF</u>	1-3/8 6B Driveline 1-3/8 -21 Driveline 1-3/4 -20 Driveline	Standard N/A N/A	N/A Standard Optional
<u>BLOWER FAN SPEED</u>		540 RPM	650 RPM
<u>GEARBOX</u>	Cast Iron Lubricant	N/A N/A	Oil Bath 6 EP Synthetic Gear Lube (6) Qts
<u>OVERALL HEIGHT</u> (with wheels)		74-1/4"	74-1/4"
<u>OVERALL LENGTH</u> (less hitch) (Including hitch)		74-5/8"	74-5/8"
<u>OVERALL WIDTH</u>		101"	101"
<u>SHIPPING WEIGHT</u> (approx.)		1700 lbs.	1900 lbs.
<u>DRIVE TYPE</u>	Fan Auger	PTO(direct) Belt	PTO to Gearbox Belt
<u>WHEELS</u>	Bearings Size Track Width	Tapered Rollers 4.80/4.00 x 8 76-1/2"	Tapered Rollers 4.80/4.00 x 8 76-1/2"
<u>BEARINGS</u>	Fan Other Drive Members	Re-lube Ball Re-lube Ball	Re-lube Ball Re-lube Ball
<u>BLOWER HOUSING AND FAN</u>	Fan width Feed Entry Opening Housing Diameter Number of Paddles Paddle Length	6-3/8" 466 sq.in. 60" 8 20-3/4"	6-3/8" 466 sq.in. 60" 8 20-3/4"
<u>HITCH HEIGHT</u>		Adjustable	Adjustable
<u>HOPPER</u>	Auger Diameter Height (with frame on ground) Height (with wheels mounted) Hopper extends from Blower Type Width	12" 20-1/2" 27-1/2" 35-1/8" Auger 37-1/4"	12" 20-1/2" 27-1/2" 35-1/8" Auger 37-1/4"

WARRANTY

ART'S-WAY MANUFACTURING CO., INC. warrants new Miller Forage Blower to be free from defects in material and workmanship under recommended use and service, as stated in the Operator's Manual, as follows:

1. **Base Warranty.** Art's-Way will replace, F.O.B Armstrong, IA, or repair, as Art's-Way elects, any part of a new Miller Forage Blower which is defective in material or workmanship:
 - (a) without charge for either parts or labor during the first year following delivery to the original retail customer; and

The warranty period for equipment used for commercial, industrial, lease, rental and custom operation or any non agricultural use is limited to 90 days from date of delivery to the first retail purchaser.

All warranties on the new Miller Forage Blower shall apply only to the original retail purchaser from an authorized Miller dealer.

Repair Parts

Art's-Way warrants that it will replace, F.O.B. Armstrong, IA, or repair, as Art's-Way elects, without charge, any genuine Miller spare part purchased after the expiration of the new Forage Blower warranty, or to any subsequent owners, that is defective in material or workmanship, within ninety (90) days of the installation date.

Misuse

The provisions of this warranty shall not apply to any Miller Forage Blower which has been subject to misuse, negligence, alteration or accident, or which shall have been repaired with parts other than those obtainable through Art's-Way.

Authorized Dealer

Repairs eligible for labor warranty must be made by Art's-Way or an authorized Miller dealer. The purchaser is responsible for transportation of the equipment to the dealership for warranty service or for any service call expense.

Exclusive Effect of Warranty and Limitation of Liability

The remedies of the customer set forth herein are exclusive. Art's-Way neither assumes nor authorized any person to assume any other obligation or liability in connection with the sale of covered equipment. Correction of defects and malfunctions in the manner and for the applicable period of time provided above, shall constitute fulfillment of all reproducibilities of Art's-Way to the customer and Art's-Way shall not be liable for negligence, under contract, or in any other manner with respect to such equipment. IN NO EVENT SHALL THE OWNER BE ENTITLED TO RECOVER FOR INCIDENTAL OR CONSEQUENTIAL DAMAGES SUCH AS BUT NOT LIMITED TO, LOSS OF CROPS, LOSS OF PROFITS OR REVENUE, OTHER COMMERCIAL LOSSES, INCONVENIENCE OR COST OF RENTAL OF REPLACEMENT EQUIPMENT.

THIS WARRANTY IS IN LIEU OF ALL WARRANTIES OF MERCHANTABILITY, FITNESS FOR A PURPOSE OR OTHER WARRANTIES, EXPRESS OR IMPLIED.

Warranty Requirements

To be covered by warranty, each machine must be properly registered with Art's-Way within 30 days of date of original retail delivery.



Art's-Way Manufacturing Co., Inc.
