

# PARTS BOOK

PART NO. 318086B91

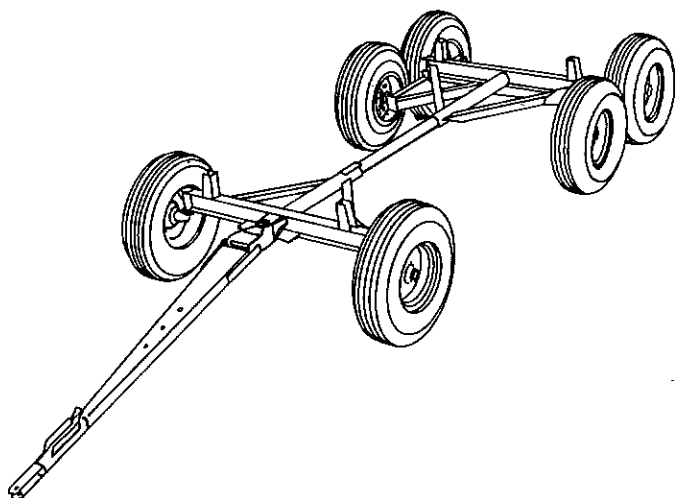

**RUNNING  
GEAR**

**MODELS BN840 - BN1060**

## GENERAL INFORMATION

THIS BOOK IS PRINTED IN TWO SECTIONS. THE FIRST SECTION CONTAINS A NUMERICAL INDEX OF ALL PART NUMBERS INCLUDED IN THIS BOOK. THE PAGES IN THIS SECTION ARE NUMBERED WITH ROMAN NUMERALS.

THE SECOND SECTION INCLUDES A GROUP INDEX AND A PART NUMBER LISTING REFERENCED TO ITEM NUMBERS ON THE ILLUSTRATED PAGE DIRECTLY OPPOSITE. PAGES IN THIS SECTION ARE NUMBERED WITH ARABIC NUMERALS.

THE PAGE NUMBERS APPEAR IN THE CIRCLE AT THE LOWER OUTER CORNER OF THE PAGE. PARTS BOOK NUMBER AND DATE APPEAR IN THE UPPER RIGHT HAND CORNER OF THE PAGE. THE PART NUMBER LISTING PAGE WILL ALSO CARRY THE MACHINE NAME TO ASSIST IN IDENTIFYING THE MACHINE TO WHICH THE PARTS BOOK APPLIES.

WHEN CHANGES TO THE MACHINE MAKE IT NECESSARY, REVISED PAGES FOR THIS BOOK WILL BE ISSUED. THE REVISED PAGES WILL BE ISSUED WITH THE SAME PAGE NUMBER AS THOSE THEY REPLACE AND THE "ISSUE" NUMBER AND DATE WILL BE ADVANCED. NEW PAGES WILL CARRY AN EXISTING PAGE NUMBER WITH AN ALPHABETICAL SUFFIX.

FROM TIME TO TIME CHANGE INFORMATION WILL BE ISSUED IN THE FORM OF A "PARTS RELEASE AND CHANGE BULLETIN." INFORMATION FROM THESE BULLETINS SHOULD BE ENTERED IN THE PROPER PAGES AS SOON AS THE BULLETINS ARE RECEIVED.

WHENEVER A PAGE OF THIS BOOK IS RE-ISSUED, THE CURRENT PAGE LISTING WILL ALSO BE RE-ISSUED. THIS LISTING WILL SHOW THE ISSUE NUMBER AND DATE OF ISSUE OF EACH PAGE AS A CHECK SHEET COVERING THE ENTIRE BOOK.

IT IS IMPERATIVE THAT REVISED PARTS BOOK PAGES BE INSERTED INTO THEIR RESPECTIVE PARTS BOOKS AS SOON AS RECEIVED. FAILURE TO DO SO WILL LEAD TO CONFUSION AND DEFEAT THE PURPOSE OF THE BOOK.

INDENTED PARTS IN THE DESCRIPTIVE LIST ARE A PART OF THE PRECEDING ASSEMBLY OR SUB-ASSEMBLY.

THE QUANTITY SHOWN IN THE "QUANTITY" COLUMN IS THE NUMBER OF PARTS USED ON A MACHINE EXCEPT WHERE PARTS ARE INDENTED IN DESCRIPTIVE LIST, IN THIS CASE THE QUANTITY SHOWN IS THE NUMBER REQUIRED FOR THE PRECEDING ASSEMBLY OR SUB-ASSEMBLY.

ALL PARTS SHOWN IN THIS BOOK ARE NOT TO BE OFFERED AS REPAIR PARTS. SUCH PARTS ARE CODED WITH AN "R1" SUFFIX ADDED TO THE PART NUMBER.

FOR CERTAIN PARTS SUCH AS BOLTS, NUTS, WASHERS, SHIMS, ETC. AN "X" WILL BE SHOWN IN THE "QUANTITY" COLUMN. THIS "X" INDICATES THAT THE QUANTITY TO BE USED IS "AS REQUIRED."

ALWAYS CHECK ILLUSTRATION AND NUMBER LISTING PAGE BEFORE ORDERING.

**NEVER ORDER FROM ITEM NUMBER ON ILLUSTRATION ALONE**

## NUMERICAL INDEX

Part No.	See Page	Part No.	See Page	Part No.	See Page
307462	4	315551	8	900506	4;008
307464	4	315552	7	900508	4;007;008
307466	4	315553	4	900538	4
307470	4	315554	4	900539	4
307474	4;008	315749	4	900647	4
307475	4;008	315750	4	900991	4
307476	4	315751	4	901111	7;008
307488	7;008	317522	7	901112	7;008
307492	7;008			901181	7;008
308590	4			901182	7;008
308593	4			901319	4
308603	7;008			901520	4;007;008
308607	8			901650	4
308612	4			901726	4
308613	4			901900	4
308614	4			902374	8
308615	4			902394	7
311440	7;008			902410	7;008
311442	8			902708	7;008
311638	4			902873	7
311645	7;008			902875	7
311646	7			903437	4;007;008
311647	7;008			903748	7
311648	4;007;008			903749	7
311650	8				
311651	8				
311652	8				
313069	7				
315364	4				
315365	4				
315366	7	900369	4;008		
315367	8	900370	7;008		
315541	4	900371	4		
315542	4;007;008	900396	4		
315545	4	900397	4;007;008		
315546	4	900418	8		
315547	4	900419	4		
315548	4	900430	7;008		
315549	4	900497	4		
315550	4	900504	4		



## INDEX

Front Axle . . . . .	4
Metric Conversion Table. . . . .	2
Rear Axle, BN840 . . . . .	7
Rear Axle, BN1060. . . . .	8
Torque Specification Table . . . . .	3

## HOW TO ORDER PARTS

1. When ordering parts, first give complete Model and Serial Number of Machine.
2. Find part required on exploded view drawing. This will have a number. See Example.
3. On corresponding parts list on the opposite page, locate that number [3] in the Item Number column. When ordering parts, indicate quantity, part number and description.

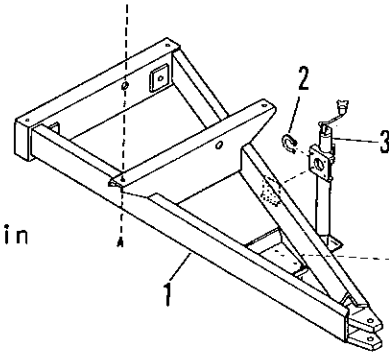

Example: If the Jack shown is needed, it should be ordered as follows:

1 - 315219 - Jack Assembly

All Parts F.O.B. Kaukauna, Wis.  
Prices subject to change without notice.



## METRIC CONVERSION TABLE

Comparing the Commonest Measurement Units

Approximate conversions from U.S. Standard to metric and vice versa.

	When you know:	You can find:	If you multiply by:
LENGTH	inches	millimeters	25
	feet	centimeters	30
	yards	meters	0.9
	miles	kilometers	1.6
	millimeters	inches	0.04
	centimeters	inches	0.4
	meters	yards	1.1
	kilometers	miles	0.6
AREA	square inches	square centimeters	6.5
	square feet	square meters	0.09
	square yards	square meters	0.8
	square miles	square kilometers	2.6
	acres	square hectometers (hectares)	0.4
	square centimeters	square inches	0.16
	square meters	square yards	1.2
	square kilometers square hectometers (hectares)	square miles acres	0.4 2.5
MASS	ounces	grams	28
	pounds	kilograms	0.45
	short tons	megagrams (metric tons)	0.9
	grams	ounces	0.035
	kilograms	pounds	2.2
	megagrams (metric tons)	short tons	1.1
LIQUID VOLUME	ounces	milliliters	30
	pints	liters	0.47
	quarts	liters	0.95
	gallons	liters	3.8
	milliliters	ounces	0.034
	liters	pints	2.1
	liters	quarts	1.06
	liters	gallons	0.26
TEMPERA- TURE	degrees Fahrenheit	degrees Celsius	$\frac{5}{9}$ (after sub- tracting 32)
	degrees Celsius	degrees Fahrenheit	$\frac{9}{5}$ (then add 32)

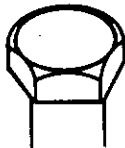
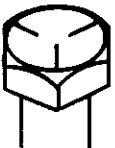
### STANDARD TORQUE SPECIFICATIONS AND CAPSCREW MARKINGS

SAE Grade Number	2		5		6 or 7		8	
<b>Capscrew Head Markings</b> Manufacturer's marks may vary. Three-line markings on heads shown below, for example, indicate SAE Grade 5.  								
<b>Usage</b>	<b>Used Most Frequently</b>		<b>Used Frequently</b>		<b>Rarely Used</b>		<b>Used at Times</b>	
Capscrew Diameter and Minimum Tensile Strength psi (Kg/sq cm)	To 1/2 - 69,000 (4850.7000)  To 3/4 - 64,000 (4499.2000)  To 1 - 55,000 (3866.5000)		To 3/4 - 120,000 (8436.0000)  To 1 - 115,000 (8084.5000)		To 5/8 - 140,000 (9842.0000)  To 3/4 - 133,000 (9349.9000)		150,000 (10545.0000)	
<b>Quality of Material</b>	<b>Indeterminate</b>		<b>Minimum Commercial</b>		<b>Medium Commercial</b>		<b>Best Commercial</b>	
Capscrew Body Size (Inches) - (Thread)	<b>Torque</b>		<b>Torque</b>		<b>Torque</b>		<b>Torque</b>	
	Ft-Lb	kgm	Ft-Lb	kgm	Ft-Lb	kgm	Ft-Lb	kgm
1/4 -20 -28	5 6	0.6915 0.8298	8 10	1.1064 1.3830	10	1.3830	12 14	1.6596 1.9362
5/16 -18 -24	11 13	1.5213 1.7979	17 19	2.3511 2.6277	19	2.6277	24 27	3.3192 3.7341
3/8 -16 -24	18 20	2.4894 2.7660	31 35	4.2873 4.8405	34	4.7022	44 49	6.0852 6.7767
7/16 -14 -20	28 30	3.8132 4.1490	49 55	6.7767 7.6065	55	7.6065	70 78	9.6810 10.7874
1/2 -13 -20	39 41	5.3937 5.6703	75 85	10.3725 11.7555	85	11.7555	105 120	14.5215 16.5960
9/16 -12 -18	51 55	7.0533 7.6065	110 120	15.2130 16.5960	120	16.5960	155 170	21.4365 23.5110
5/8 -11 -18	83 95	11.4789 13.1385	150 170	20.7450 23.5110	167	23.0961	210 240	29.0430 33.1920
3/4 -10 -16	105 115	14.5215 15.9045	270 295	37.3410 40.7985	280	38.7240	375 420	51.8625 58.0860
7/8 - 9 -14	160 175	22.1280 24.2025	395 435	54.6285 60.1605	440	60.8520	605 675	83.6715 93.3525
1 - 8 -14	235 250	32.5005 34.5750	590 660	81.5970 91.2780	660	91.2780	910 990	125.8530 136.9170

**FRONT AXLE**  
(BN840 - BN1060)

ITEM NO.	PART NO.	DESCRIPTION	QUANTITY
X	315365	Axle Assembly.....	1
2	315550	Axle Sub-Ass'y.....	1
3	<del>307475</del> MP900073	Bushings.....	4
4	900538	Zerk.....	2
5	315547	Rod, Tie.....	2
6	315751	Bushing.....	1
7	315545	Bolt [3/4 x 4 Special, NF].....	1
8	901319	Nut [3/4 Castle, NF].....	1
9	901520	Pin [3/16 x 1-1/4 Cotter].....	2
10	308590	Nut [7/8 Jam].....	2
11	311638	Clevis.....	2
12	307470	Pin, Clevis.....	2
13	901900	Pin [5/32 x 1 Cotter].....	2
14	307466	Bushing.....	2
15	315553	Spindle, Left.....	1
16	315554	Spindle, Right.....	1
17	307474	Spacer.....	2
18	307476	Washer, Felt.....	2
19	308593	Washer, Cap.....	2
20	900504	Washer [3/8 Lock].....	2
21	900396	Bolt [3/8 x 1-1/4 Hex].....	2
22	315546	Hitch Assembly.....	1
23	307462	Bushing.....	4
24	315749	Bushing.....	1
25	900539	Zerk.....	1
26	900538	Zerk.....	1
27	315750	Spacer.....	1
28	315548	Bolt [7/8 x 6 King, NF].....	1
29	901726	Nut [7/8 Castle, NF].....	1
30	315549	Bolt [7/8 x 10-1/8 Hex, NF].....	1
31	307464	Nut [7/8 Hex, Jam, NF].....	1
32	315542	Stake.....	2
33	900397	Bolt [3/8 x 1 Hex].....	8
34	903437	Nut [3/8 Whiz Lock].....	8
35	311648	Hub Ass'y. [See Page 7].....	2
36		Wheel Assembly [See Page 7].....	2
45	315364	Tongue Assembly.....	1
46	315541	Tongue.....	1
47	308612	Tube.....	1
48	308615	Extension.....	1
49	308613	Latch.....	1
50	308614	Spring.....	1
51	900647	Bolt [5/8 x 4 Hex].....	1
52	900508	Washer [5/8 Lock].....	1
53	900371	Nut [5/8 Hex].....	1
54	900419	Bolt [1/2 x 4 Hex].....	1
55	900497	Washer [1/2 Flat].....	1
56	900506	Washer [1/2 Lock].....	1
57	900369	Nut [1/2 Hex].....	1
58	900991	Bolt [1/2 x 3-1/2 Hex].....	1
59	901650	Nut [1/2 Hex, Lock].....	1



# FRONT AXLE (BN840 - BN1060)

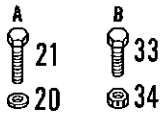
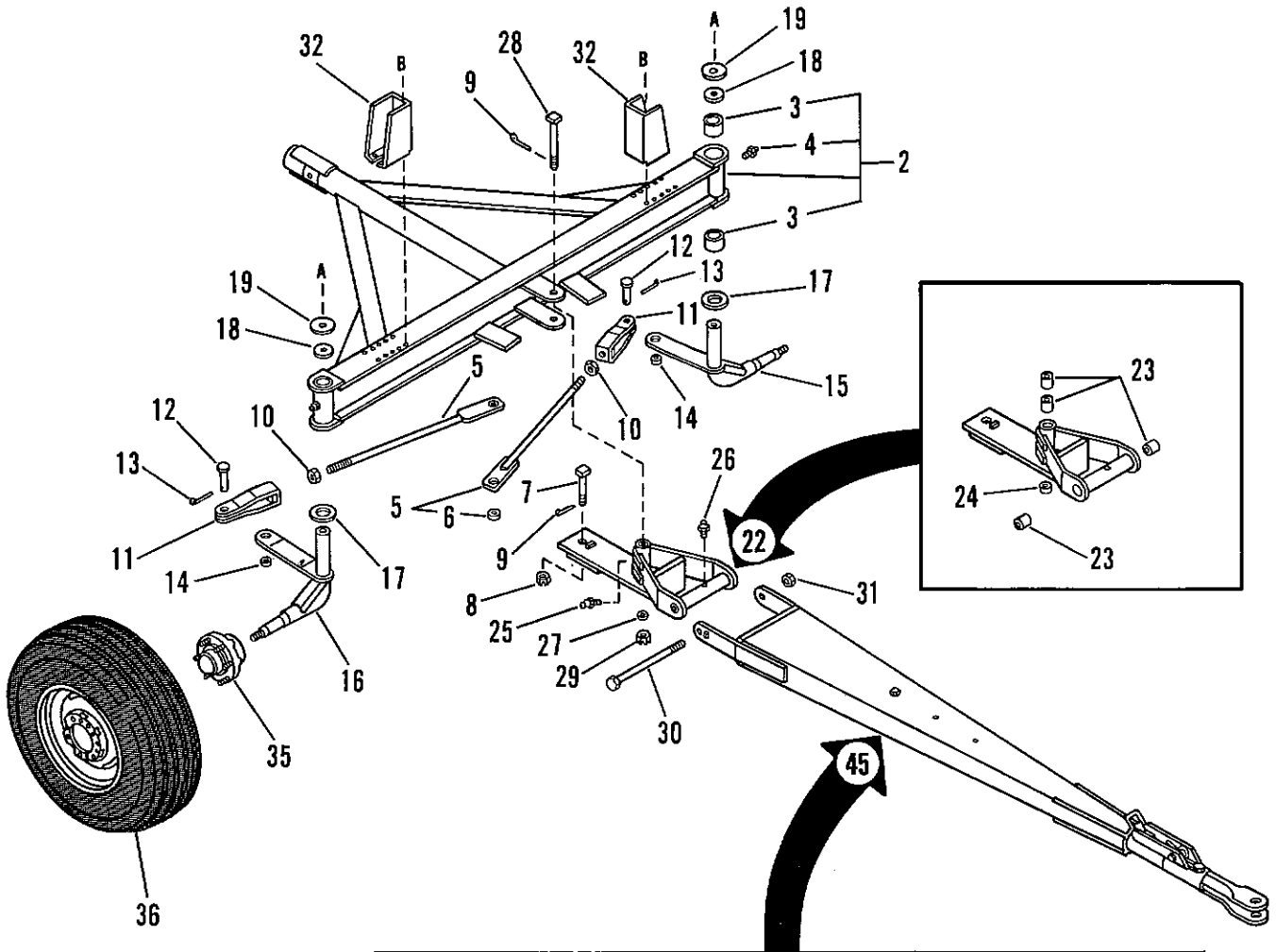

8008-1(Y)

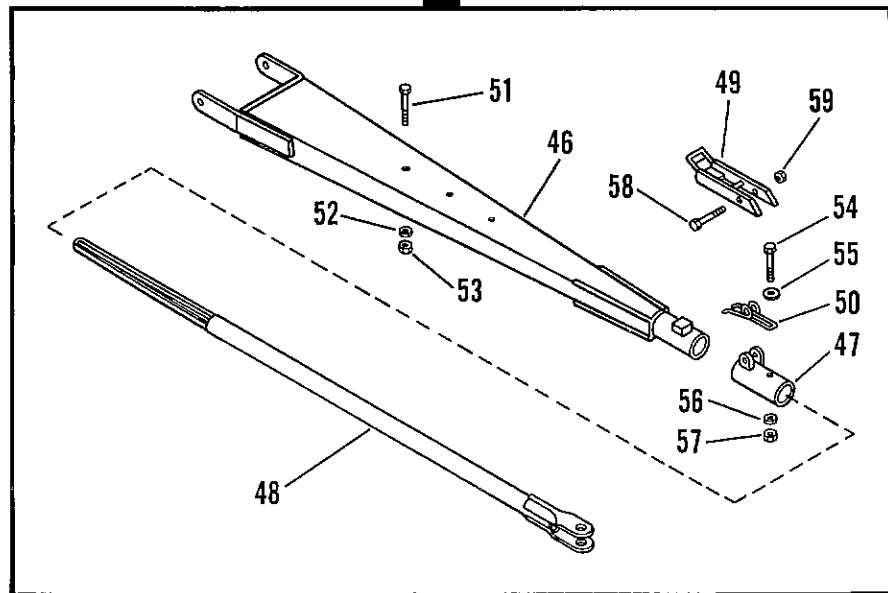

# SINGLE AXLE (BN840)

8009-1(Y)

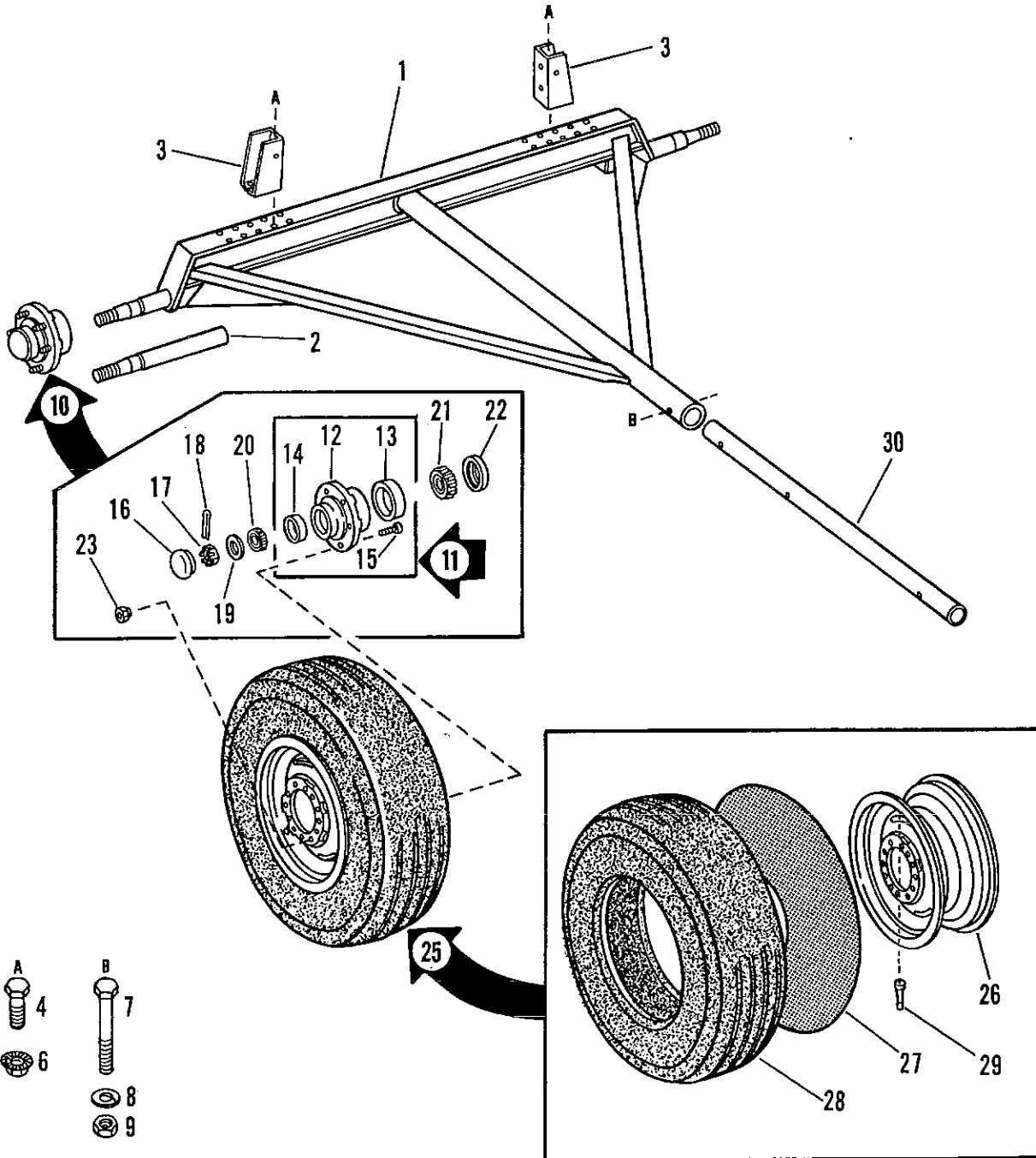

# SINGLE AXLE

(BN840)

ITEM NO.	PART NO.	DESCRIPTION	QUANTITY
X	315366	Axle Assembly, 8 Ton.....	1
1	315552	Axle, Sub-Assembly.....	1
2	311646	Spindle.....	2
3	315542	Stake.....	2
4	900397	Bolt [3/8 x 1 Hex].....	8
6	903437	Nut [3/8 Whiz Lock].....	8
7	900430	Bolt [5/8 x 4-1/2 Hex].....	1
8	900508	Washer [5/8 Lock].....	1
9	900370	Nut [5/8 Hex].....	1
10	311648	Hub Assembly.....	2
11	311647	Hub, Sub-Assembly.....	1
12		Hub [Order 311647]. <i>not w/ bearings</i>	1
13	901111	Cup.....	1
14	901182	Cup, Outer.....	1
15	307488	Stud.....	6
16	902410	Cap, Grease [Was 307493].....	1
17	307492	Nut [3/4 Spindle].....	1
18	901520	Pin [3/16 x 1-1/2 Cotter].....	1
19	308603	Washer.....	1
20	901181	Bearing, Outer.....	1
21	901112	Bearing, Inner.....	1
22	902708	Seal.....	1
23	311645	Nut [1/2 Lug].....	6
25	313069	Wheel Assembly.....	2
26	902394	Rim [15 x 8; 1-1/8].....	1
27	902873	Tube.....	1
28	902875	Tire [10:00 x 15].....	1
25	317522	Wheel Assembly.....	2
26	902394	Rim [15 x 8; 1-1/8].....	1
28	903748	Tire [10:00 x 15; Tubeless].....	1
29	903749	Valve.....	1
30	311440	Reach Tube.....	1

## TANDEM AXLE

(BN1060)

ITEM NO.	PART NO.	DESCRIPTION	QUANTITY
X	315367	Axle Assembly, Rear .....	1
1	315551	Axle .....	1
2	315542	Stake .....	2
3	900397	Bolt [3/8 x 1 Hex] .....	8
5	903437	Nut [3/8 Whiz Lock] .....	8
6	900430	Bolt [5/8 x 4-1/2 Hex] .....	1
7	900508	Washer [5/8 Lock] .....	1
8	900370	Nut [5/8 Hex] .....	1
10	311442	Walking Beam Assembly .....	2
11	311652	Tandem Axle Assembly .....	1
12	311651	Brace .....	4
13	311650	Spindle .....	2
14	307475	Bushing .....	3
15	902374	Zerk .....	1
16	308607	Shaft, Pivot .....	1
17	307474	Spacer .....	1
18	900418	Bolt [1/2 x 3 Hex] .....	1
19	900506	Washer [1/2 Lock] .....	1
20	900369	Nut [1/2 Hex] .....	1
21	311648	Hub Assembly .....	2
22	311647	Hub Sub-Assembly .....	1
23		Hub [Order 311647] .....	1
24	901111	Cup, Inner .....	1
25	901182	Cup, Outer .....	1
26	307488	Stud .....	6
27	902410	Cap, Grease [Was 307493] .....	1
28	307492	Nut [3/4 Spindle] .....	1
29	308603	Washer .....	1
30	901181	Bearing, Outer .....	1
31	901112	Bearing, Inner .....	1
32	902708	Seal .....	1
33	311645	Nut [1/2 Lug] .....	6
34	901520	Pin [3/16 x 1-1/2 Cotter] .....	1
35		Wheel Assembly [See Page 7].....	4
40	311440	Reach Tube .....	1

# TANDEM AXLE (BN1060)

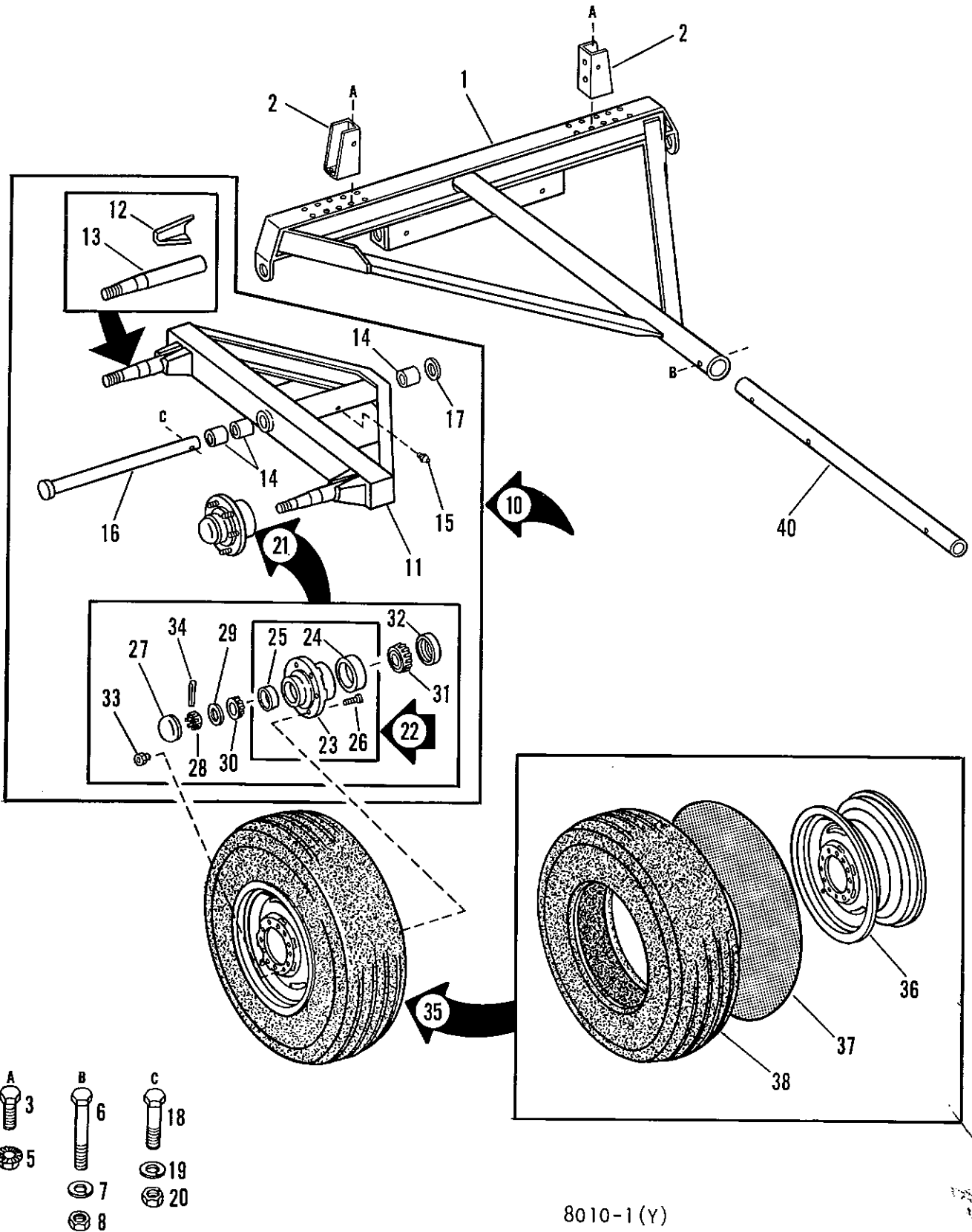

8010-1(Y)



