

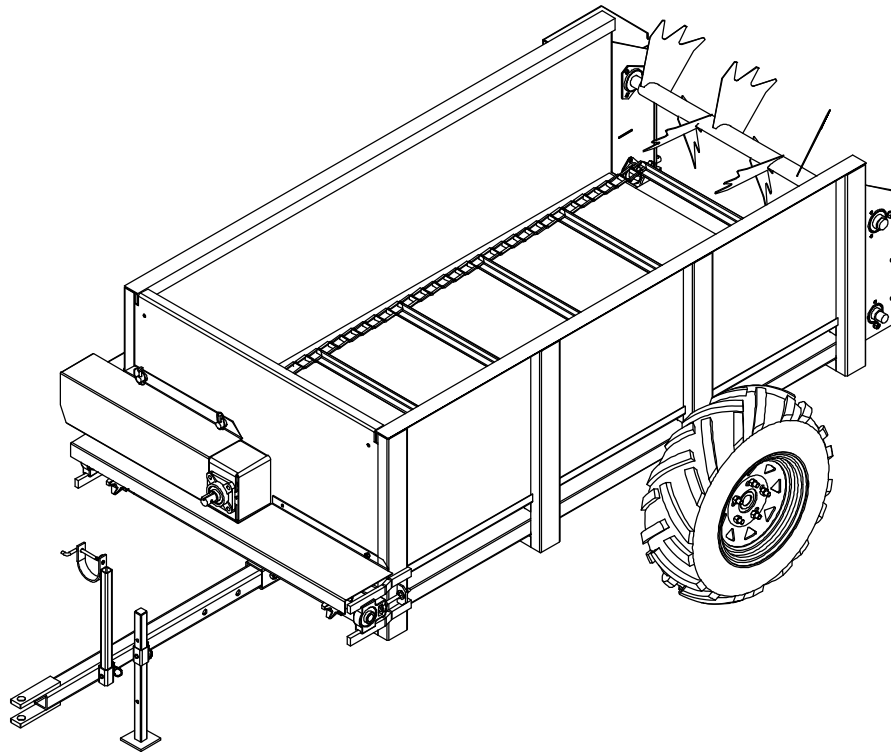

50 BUSHEL PTO DRIVE MANURE SPREADER



**RODA MANUFACTURING
1008 LOCUST ST.
HULL, IA. 51239
712-439-2366
WWW.RODAMFG.COM**

INTRODUCTION

Thank you for purchasing a Roda Spreader. We appreciate your business. Here at Roda, we do our best to provide you with a rugged and durable unit, which is easy to maintain. If you have any suggestions for any of our products, please let us know.

Roda Manufacturing Inc.

USING THIS MANUAL

This manual should be considered a permanent part of your machine, and should remain with the machine when you sell it.

This manual has been designed to help you become familiar with your unit. Before you operate your unit, be sure you understand and follow all the operation, safety, and lubrication instructions on the following pages in this manual. These have been written for your safety and convenience, and to help keep your unit running trouble-free for many years.

ADDITIONAL OPERATORS MANUALS, SERVICE PARTS LISTINGS and safety decals may be obtained through your dealer, or Roda Manufacturing.

TABLE OF CONTENTS

Introduction	3
Safety	4-6
Safety Decals & Location	6-8
Manure Spreader Safety	9-10
Pre-Operation	11
Lubrication	12
Inspection & Adjustments	13-14
Spreader Operation	14-15
Frame and Shields Breakdown	16
Wheel and Axle Breakdown	17
Front View Breakdown	18-19
Rear View Breakdown	20-21
Limited Warranty	23
Warranty Registration	25



UNDERSTAND SAFETY WORDS AND SYMBOLS



THIS SAFETY ALERT SYMBOL is used in this manual whenever personal safety is involved and means **ATTENTION! BECOME ALERT!** It stresses an attitude of “**HEADS UP**” for safety. Read and understand all pages in this manual that bear this safety symbol and...**TAKE TIME TO BE CAREFUL!**

The Signal Word or Message areas of all safety decals are color coded to indicate the level of hazard.

CAUTION: Is used to direct attention to unsafe practices, and uses the color yellow.

WARNING: Denotes a specific potential hazard, and uses the color yellow or orange.

DANGER: Denotes a most serious specific potential hazard, and uses the color red.

READ THE OPERATORS MANUAL

Any person who will be operating or maintaining this manure spreader should first read and understand this manual and all safety warnings on the unit.

This instruction manual should always be available to those responsible for the operation and maintenance of this manure spreader. It is the owner's responsibility to provide this safety information to his operators and employees.

Any person who does not understand the safety and operation instructions contained in this manual should not be considered qualified to operate this manure spreader.

FOLLOW SAFETY INSTRUCTIONS

Specialized procedures and instructions are required and must be adhered to when working on this equipment. Failure to follow the instructions contained in this manual could result in severe personal injury, death, and/or product or property damage. Personnel when operating or maintaining this equipment must use all applicable safety procedures such as OSHA requirements, regional and local safety codes and requirements, safe working practices, and good judgment.



OPERATING SAFETY PRECAUTIONS



WHEN THE SPREADER IS IN OPERATION, IT HAS MANY MOVING PARTS, WHICH COULD CAUSE SEVERE INJURY OR DEATH TO PERSONS COMING IN CONTACT WITH THESE PARTS. TO HELP AVOID SERIOUS ACCIDENTS, THE FOLLOWING GUIDELINES MUST BE FOLLOWED.

- **BE SURE ALL SAFETY SHIELDS** are in place before operating, including any truck and driveline shields. Exposed machinery, due to missing shielding, can cause severe injury or death. Repair or replace any damaged or missing shielding.
- **NEVER PUT ARMS OR FEET INSIDE UNIT**, or near discharge areas, nor climb on or in the spreader while it is running. NEVER allow anyone to position themselves over or near the top, or near the discharge area of the spreader while it is running. Rotating beaters, shafting, belts, pulleys, and sprockets can grab clothing or create pinch points, which can cause severe injury or death to the operator or bystanders. Always stop engine and remove ignition key so that the spreader cannot be accidentally turned on while inspection, servicing, repairing, or cleaning the spreader.
- **NEVER ATTEMPT TO RELEASE JAMMED MATERIALS OR CLEAN MATERIALS** from any area of the spreader or discharge without turning the spreader off first. Materials can hide moving parts and stopped parts can start unexpectedly, causing severe injury. Always stop engine and remove ignition key before attempting to remove jammed material or clean the spreader.
- **DO NOT ALLOW OPERATION OF THIS UNIT BY AN INEXPERIENCED OR UNQUALIFIED PERSON.** Keep all unqualified people away from spreader during operation. Operators of this unit must be alert and use good judgment at all times and must have fully read and understand this manual.
- **DO NOT WEAR LOOSE OR FLOPPY CLOTHING** while operating this unit. Loose clothing may become entangled in moving machinery.
- **BE SURE THE INSIDE OF SPREADER IS CLEAR** of any obstructions before loading.
- **SHOULD A PROBLEM OCCUR DURING THE OPERATION OF SPREADER, always turn off engine and remove ignition key before investigating problem.** If power source has not been turned off, the spreader may start unexpectedly, causing severe injury or death.



TRANSPORTING SAFETY PRECAUTIONS



WHEN TRANSPORTING A LOADED SPREADER, USE REDUCED SPEED AND BE SURE THE VEHICLE HAS ADEQUATE BRAKES TO STOP.

- **DO NOT ALLOW ANYONE TO RIDE ON OR INSIDE THE SPREADER.**
- **REDUCE SPEED WHEN TRAVELING** loaded and/or over rough, soft, or wet terrain. Exercise caution on side slopes and when turning corners.
- **AVOID OPERATING THE SPREADER CROSSING GULLIES OR DITCHES.**
- **WHEN WORKING ON SLOPES** or inclines, travel uphill or downhill. Keep the transmission in gear when going downhill.
- **AVOID DRIVING ON** loose fill, rocks, inclines, ditches, and holes.
- **ALWAYS PARK** the spreader on level ground and block the tires.
- **IF UNIT IS FOR HIGHWAY TRANSIT** the end user is responsible for federal, state and local vehicle safety regulation compliance (example: under ride requirements, lighting and weight limitations).

SAFETY DECALS

SAFETY DECALS ARE PLACED ON THIS UNIT FOR THE PROTECTION OF THE OPERATOR OR ANY PERSON NEAR THE UNIT.

- **BE SURE EVERYONE WHO OPERATES THE SPREADER UNDERSTANDS ALL THE INFORMATION, WARNING, CAUTION AND DANGER DECALS.**
- **KEEP THE DECALS CLEAN** so they are readable. This applies to all caution, warning, and danger decals.
- It is the **OWNER'S RESPONSIBILITY** to provide information for safe operation of this machine.
- **REPLACE ANY DAMAGED OR WORN DECAL.** Once any part of a decal becomes non-readable, it should be replaced. Replacement decals may be ordered through your dealer or Roda Manufacturing.
- **WHEN REPLACING DECALS,** be sure the surface area is clean and dry, peel the backing off the decal, and apply to the unit. Be sure to wipe with a clean cloth to rub out all air bubbles to assure a good seal. For best adhesion decals should be applied in temperatures of 50°(f) or warmer.

SAFETY

SAFETY DECALS

1.)



2.)



3.)

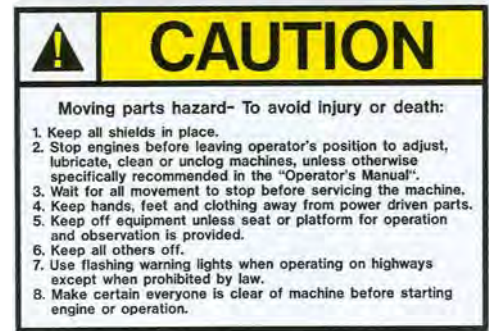

4.)



5.)



6.)



7.)



8.)



 **SAFETY**

SAFETY DECAL LOCATION

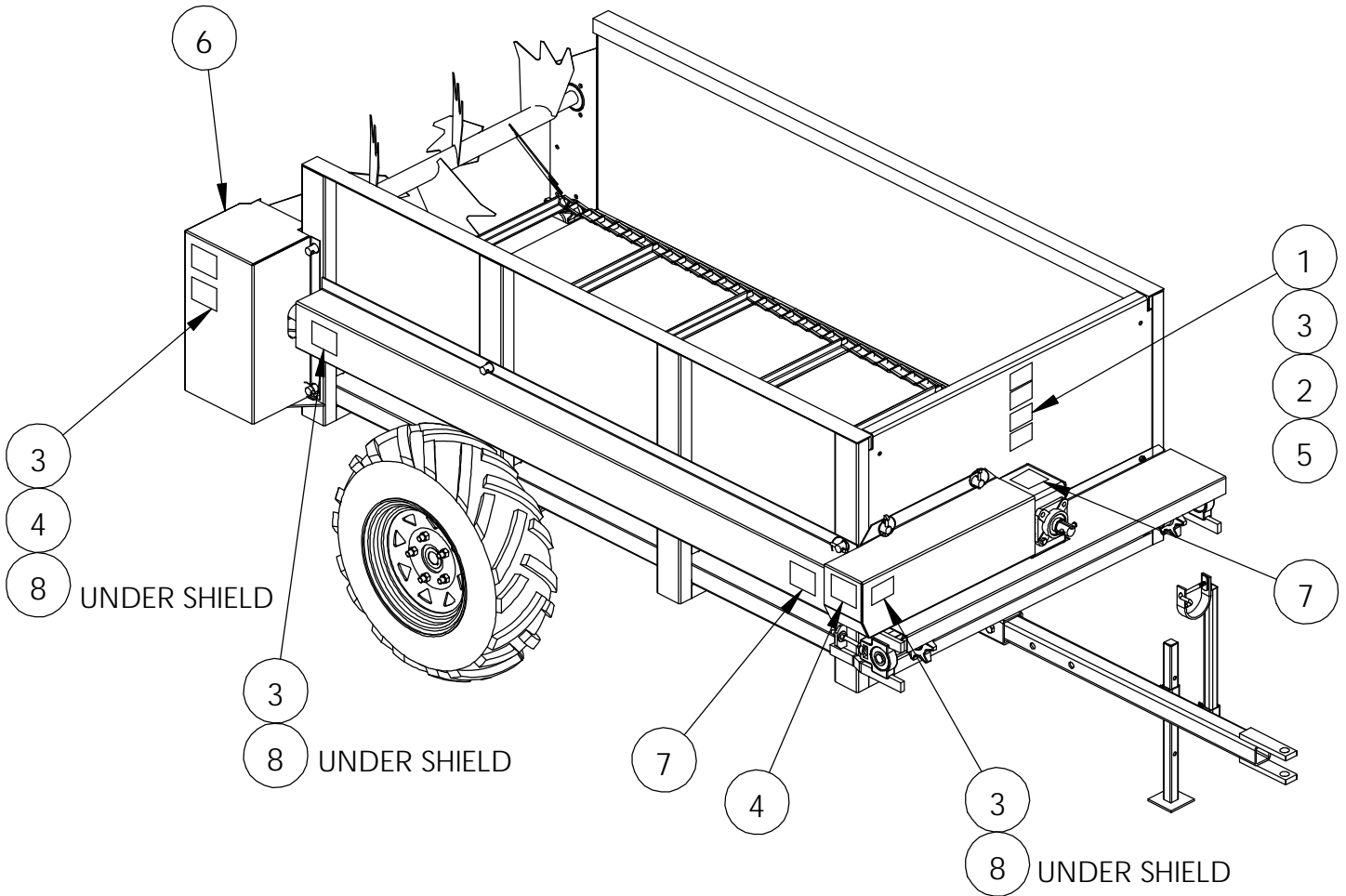

MODEL AND SERIAL NUMBER INFORMATION is located in the upper center area of the front panel. This is the number to give service personnel for parts and service questions.



MANURE SPREADER SAFETY



THERE ARE INHERENT HAZARDS ASSOCIATED WITH THE OPERATION OF A MANURE SPREADER. FOR YOUR SAFETY:

- **ONLY PROPERLY INSTRUCTED PEOPLE SHOULD OPERATE THE SPREADER.** Do not allow children or inexperienced persons to operate spreader.
- **KEEP ALL GUARDS AND SHIELDS IN PLACE.** Moving parts can crush and dismember.
- **CLEAR THE AREA** before equipment start up.
- **KEEP HANDS, FEET, AND LOOSE CLOTHING AWAY FROM ANY MOVING PARTS.**
- **DO NOT GO NEAR THE SPREADER WHILE THE MACHINE IS OPERATING.**
- **MAKE SURE THE PTO IS SECURELY LOCKED** to both the tractor and spreader before operating this unit.
- **DO NOT OPERATE PTO AT SPEEDS HIGHER** than manufacturer's recommendations.
- **HIGHWAY TRAFFIC IS NOT TO EXCEED 10 MPH.** The tires supplied are for farm use only and are not designed for use above this speed.
- **USE ADEQUATE SAFETY CHAINS** when towing the spreader.
- **USE OF A SLOW MOVING VEHICLE SIGN IS REQUIRED** on all public roads. Obey all applicable highway safety laws and rules.
- **ALWAYS USE A TRACTOR LARGE ENOUGH TO PROVIDE SUFFICIENT BRAKING** assistance when towing a loaded spreader.
- **USE CAUTION WHEN TRAVELING** over uneven terrain and when approaching stops.
- **DO NOT LOAD THE SPREADER** unless it is hitched to the tractor.
- **DO NOT UNHITCH A LOADED SPREADER** from the tractor. Leaving it supported by only the jack.
- **PARK THE SPREADER ON LEVEL GROUND** and place blocks ahead of and behind the wheels before unhooking from tractor to avoid unexpected rolling when separated from vehicle
- **DO NOT ALLOW RIDERS ON THE SPREADER.**



**FAILURE TO HEED MAY RESULT IN SERIOUS PERSONAL INJURY OR DEATH
THERE ARE ADDITIONAL HAZARDS ASSOCIATED WITH THE SERVICE AND MAINTENENCE
OF YOUR SPREADER.**

FOR YOUR SAFETY:

- **INSPECT** when first delivered and regularly thereafter; that all connections and bolts are tight and secure before operating.
- **RETIGHTEN ALL WHEEL BOLTS** after the first hour of towing. Check periodically thereafter.
- **MAINTAIN PROPER TIRE AIR PRESSURE** at all times.
- **ALWAYS WEAR EYE PROTECTION** when operating or servicing spreader.
- **BE SURE ALL MOVEMENT HAS STOPPED** and that the PTO is disconnected and the tractor is shut off before servicing the spreader or components.
- **NEVER MAKE ANY ALTERATIONS** or modifications to this equipment.



FAILURE TO HEED MAY RESULT IN SERIOUS PERSONAL INJURY OR DEATH

PRE-OPERATION

IMPORTANT: READ BEFORE OPERATING SPREADER.

IT IS THE RESPONSIBILITY OF THE OWNER TO MAKE SURE THE SPREADER IS SET UP PROPERLY. THE FOLLOWING RECOMMENDATIONS SHOULD BE HELPFUL.

- **CHECK FOR PROPER ASSEMBLY**, adjustment and lubrication. Check to be sure all bolts and setscrews are tight. Check to be sure that all chains and chain tighteners are properly adjusted. Review Operating Safety Precautions and Lubrication instructions for more information.
- **BE SURE ALL SHIELDS** are properly in place, including any drive-line shields
- **CHECK FOR AND REMOVE ANY FOREIGN OBJECTS** in the spreader box and discharge area.
- **BE SURE NO ONE IS NEAR THE SPREADER.**
- **TEST RUN THE SPREADER.**
- **WITH THE SPREADER EMPTY**, start the apron and beater.
- **RUN FOR AT LEAST 5 MINUTES.**
- **CHECK THE SPREADER DRIVE COMPONENTS TO BE SURE THEY ARE NOT ABNORMALLY HOT.**

If any of these items are not running as indicated, immediately repair or contact your service representative. Always refer to Operating Safety Precautions before operating or servicing the spreader.



LUBRICATION

ALWAYS STOP FORAGE BOX AND DISCONNECT POWER BEFORE SERVICING, REPAIRING, OR CLEANING. USE SAFE SHOP PROCEDURE AND EXERCISE CAUTION WHEN WORKING ON THIS MACHINE!

It is extremely important to properly lubricate your new RODA machine before it is used for the first time. If the mechanical drive components of your unit are not protected from shock and frictional abrasion, the wear rate of these components will be vastly accelerated and their life span will be drastically reduced. For proper care and maintenance, your machine should be serviced with engine oil, multipurpose grease, and fluids specified below.

It is extremely important that the lubrication guide be followed. For lubricating bearings, use good quality multipurpose grease. Pump the grease in slowly. Roller chains should be lubricated with engine oil, or a spray-on chain lubricant and then the spreader operated under a no-load condition. This will allow the roller chains to be thoroughly lubricated and thus minimize heat-up during operation.

DESCRIPTION	INTERVAL	LUBRICANT
ROLLER CHAINS	8-10 HOURS	OIL
APRON TIGHTENER BEARINGS	8-10 HOURS	GREASE
AXLE BEARINGS	8-10 HOURS	GREASE
PTO BEARINGS	8-10 HOURS	GREASE
WORM GEARBOX	40 HOURS	EP90 GEAR LUBE
GEARBOX	40 HOURS	EP90 GEAR LUBE
APRON CHAIN	WHEN PARKED	30WT OIL

ALWAYS REPLACE ALL SHIELDS AFTER MAINTENANCE AND LUBRICATION IS COMPLETE

INSPECTION & ADJUSTMENTS

ALWAYS STOP SPREADER, SHUT OFF VEHICLE ENGINE AND REMOVE IGNITION KEY BEFORE SERVICING, REPAIRING, OR CLEANING, USE SAFE SHOP PROCEDURES AND EXERCISE CAUTION WHEN WORKING ON THIS SPREADER!

- **SHIELDING** to be sure all shielding is in place and functioning properly. Replace all damaged or missing shielding immediately-Contact your nearest dealer or the Roda parts/service dept. for more information. Check bolts and Set Screws after a few hours of use and each month thereafter, and tighten if necessary.
- **AFTER A FEW HOURS OF INITIAL OPERATION**, check all bolts and set screws to be sure they are tight and secure.
- **ROLLER CHAIN TIGHTENERS** to apply sufficient tension to keep roller chains running smoothly. The chain will form grooves in the tightener blocks. These grooves help to keep the chains in proper alignment, and the blocks should not be turned unless the roller portion of the chain has worn into the block
- **ROLLER CHAINS FOR WEAR**, proper alignment and tension, and adjust or replace if necessary. Roller chain connector links that pull over tightener blocks must have the legs of the cotter pins facing the trailing end.
- **SAFETY DECALS FOR READABILITY**. If any safety decals are removed, obstructed, or otherwise not understandable, they should be replaced immediately. Keep all decals clean!
- **IMPORTANT: IF YOU WELD ON THIS UNIT: Do Not** allow the currents to flow through the bearings. Ground directly to the item being welded.
- **PERIODICALLY CHECK** all set screws and bolts and retighten if necessary.
- **APRON CHAINS** for wear, proper alignment and tension, according to the adjustment guidelines as shown.
- **BE SURE TO KEEP PROPER TENSION ON APRON CHAINS**. The (2) apron tightener bolts are located at the front of the unit at each end of the apron shaft. They should be adjusted evenly for their respective assembly as shown below:

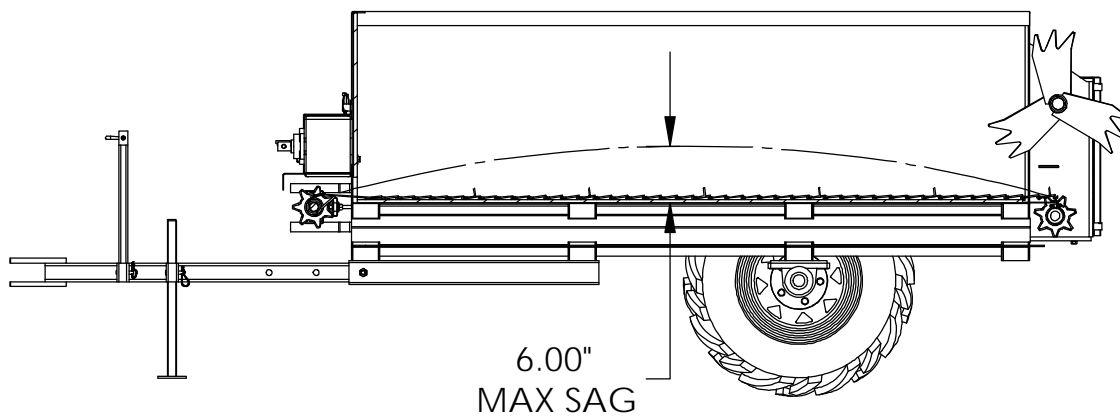

Grab apron in the center and pull up. There should be no more than 6” of sag. If apron is loose, remove one link from each side of that apron chain assembly and readjust to tension as shown. **CAUTION:** Over tightening can cause premature failure of the drive components.

SPREADER OPERATION

ALWAYS REFER TO THE OPERATING SAFETY PRECAUTIONS AND SAFETY DECAL SECTIONS OF THIS MANUAL BEFORE OPERATING THIS SPREADER

LOADING

- **BEFORE LOADING THE SPREADER**, be sure there are no obstructions in the beaters or discharge opening. Inspect the spreader to see that it is in good mechanical condition and that all shields are in place and functional.
- **NEVER CHECK THE SPREADER WHILE IT IS OPERATING**
- **IN FREEZING WEATHER**, make sure the apron is not frozen with manure. If this appears likely, turn off vehicle engine, remove ignition keys, loosen the frozen area and operate before loading.
- **AVOID LOADING ROCKS AND OTHER SOLID OBJECTS INTO THE SPREADER**
- **NEVER COVER BEATERS** when loading, beaters should spin freely before engaging.

OPERATION

- **BEFORE OPERATING, BE SURE NO ONE IS NEAR THE SPREADER AND THAT THE DISCHARGE AREA IS CLEAR OF ALL OBJECTS OR PERSONS THAT COULD BE HARMED IF MATERIAL WAS DISCHARGED!**
- **WITH THE VEHICLE STOPPED** and the engine throttled down, engage the PTO lever.
- **START VEHICLE IN MOTION.**
- **THE SPREAD RATE IS CONTROLLED BY THE VEHICLE GROUND SPEED.** The type of material being spread affects the rate at which material is discharged from the spreader. Semi-liquid materials will discharge faster than the more solid type materials.
- **WHEN THE SPREADER IS EMPTY DURING FREEZING TEMPERATURES,** be sure that the spreader is cleaned out to prevent the apron from freezing down.
- **IF THE BEATER QUILTS TURNING,** stop the vehicle, turn off the motor, remove the ignition key, and check driveline of the spreader, starting in the front with the PTO and working towards the rear of the spreader.
- **NEVER LOAD THE SPREADER SO THE LOAD IS ON THE BEATERS.**

*If a problem should occur while unloading the spreader, or if you want to clean off the spreader after it is empty, NEVER leave the VEHICLE without first turning off the engine and removing ignition key.

FRAME AND SHIELDS BREAKDOWN

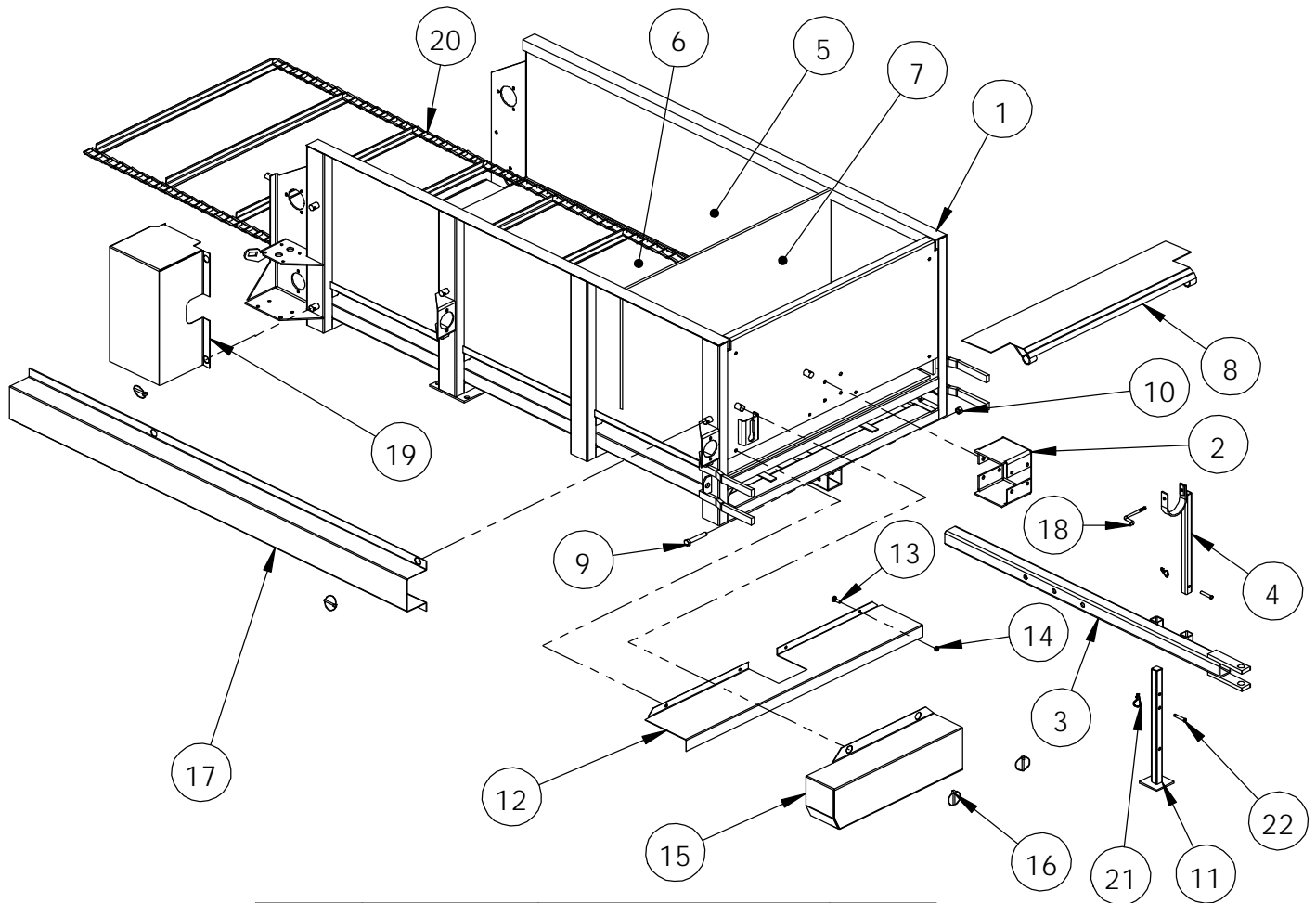

ITEM NO.	PART NUMBER	DESCRIPTION	F&S/QTY
1	50034	50 BUSHEL PTO FRAME	1
2	80006	FRONT PTO BEARING MNT	1
3	50033	TONGUE	1
4	80017	PTO HOLDER	1
5	50012	SIDE POLY PANEL	2
6	50013	POLY FLOOR PANEL	1
7	50011	POLY FRONT PANEL	1
8	50005	FRONT SHAFT COVER	1
9	HX-50-3	1/2" x 3" HEX HEAD BOLT	1
10	LN-50	1/2" LOCKNUT	1
11	25033	JACK STAND	1
12	80010	FRONT APRON SHIELD	1
13	CH-31-1	5/16" CARRIAGE BOLT,1"	4
14	LN-31	5/16" LOCKNUT	4
15	80007	CHAIN SHIELD	1
16	LP-25-1.75	1/4" LYNCH PIN	10
17	50031	SIDE SHAFT SHIELD	1
18	80018	PTO HOLDER BOLT	1
19	80009	REAR GEARBOX SHIELD	1
20	50014	15 BAR APRON	1
21	HPC-094-2.31	HAIRPIN	2
22	PP-31-1.75	5/16" x 1.75" CLEVIS PIN	2

WHEEL AND AXLE BREAKDOWN

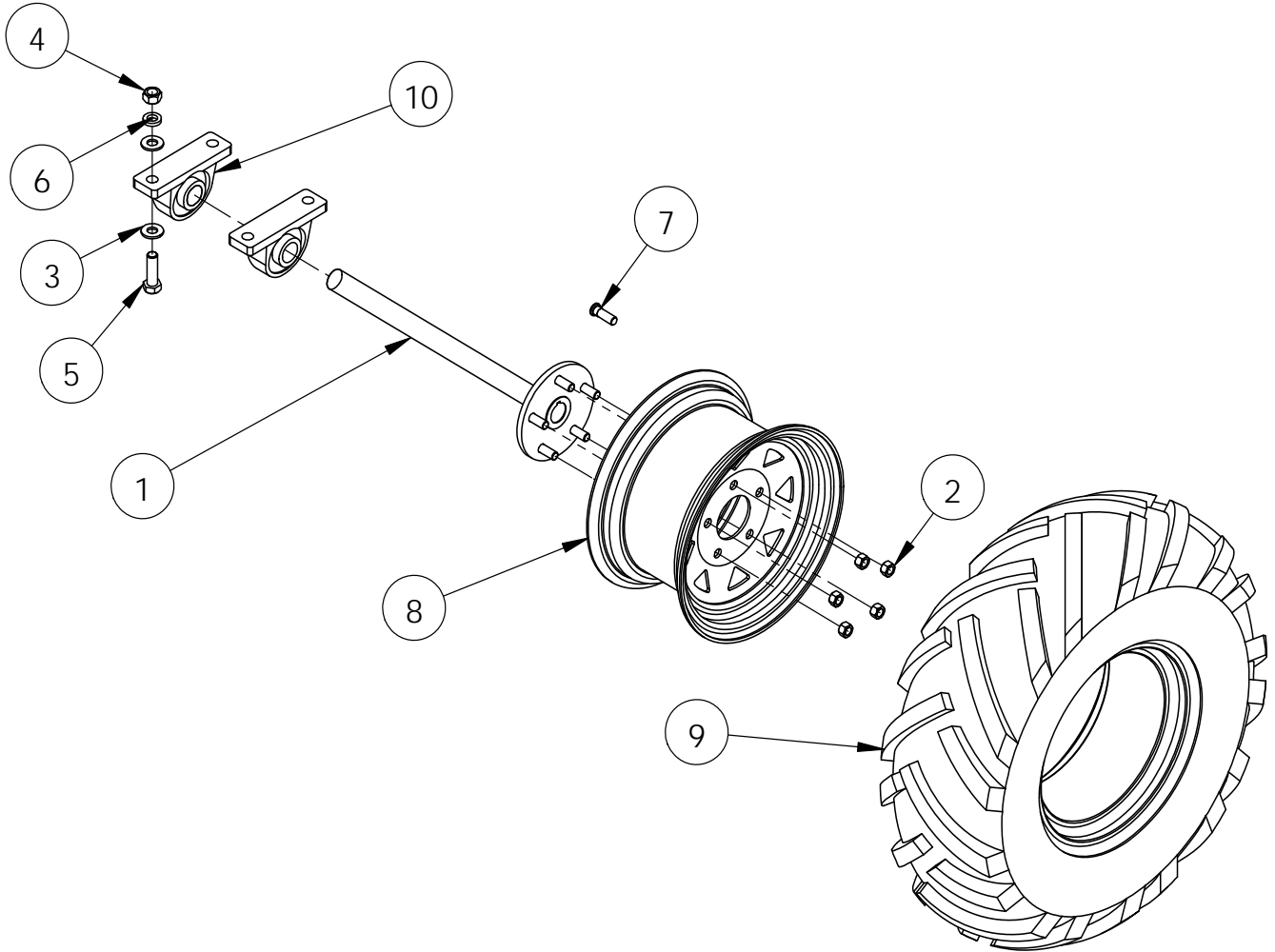

ITEM NO.	PART NUMBER	DESCRIPTION	QTY.
1	80011	AXLE	1
2	WN-50	LUG NUT	5
3	FW-63	5/8" FLAT WASHER	8
4	HN-63	5/8" HEX NUT	4
5	HX-63-2	5/8" HEX HEAD BOLT, 2"	4
6	LW-63	5/8" LOCK WASHER	4
7	25017-04	STUD	5
8	50015-01	TIRE, 23 X 8.5 - 12	1
9	50015-02	RIM, FOR 23 X 8.5 - 12	1
10	UCPL 207-20	BEARING, 1.25, PILLOW BLOCK	2

FRONT VIEW BREAKDOWN

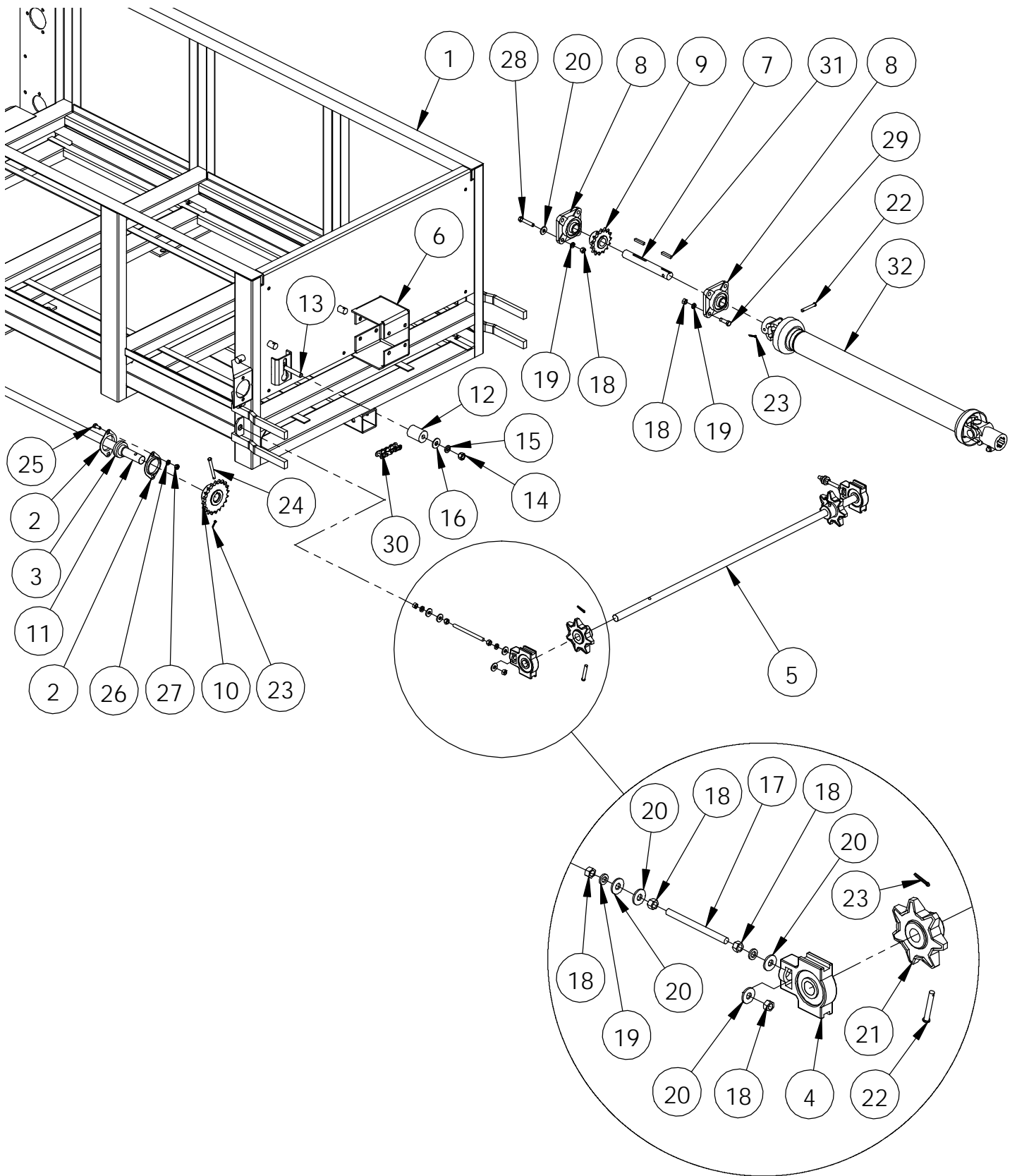

FRONT VIEW PARTS LIST

ITEM NO.	PART NUMBER	DESCRIPTION	FRONT/QTY.
1	50034	50 BUSHEL PTO FRAME	1
2	PFL-205	2-BOLT FLANGETTE, 1.00" BORE	2
3	SB205-16N	1" ID LOCKING BEARING	1
4	UTC205-14	TAKE UP UNIT	2
5	50003	FRONT APRON SHAFT	1
6	80006	FRONT PTO BEARING MNT	1
7	80005	PTO SHAFT	1
8	UCF205-16	BEARING, 1.00, 4-BOLT	2
9	5015W-1	50-15 SPROCKET 1" BORE	1
10	80026	50-20 SPROCKET W/1.25" HUB, BRONZE BUSHING	1
11	50032	1" DIA. SIDE SHAFT x 73.5"	1
12	80023-B	1.50" DIA x 2.00" PLASTIC TIGHTENER	1
13	CH-50-3	1/2" CARRIAGE BOLT, 3"	1
14	HN-50	1/2" HEX NUT	1
15	LW-50	1/2" LOCK WASHER	1
16	FW-50	1/2" FLAT WASHER	1
17	RR-38-5	.375" DIA THREADED ROD, 5"	2
18	HN-38	3/8" HEX HEAD NUT	16
19	LW-38	3/8" LOCKWASHER	12
20	FW-38	3/8" FLAT WASHER	12
21	225-R36	CAST SPROCKET, .88" BORE, 7 TOOTH	2
22	PP-31-2.13	5/16" x 2.125" CLEVIS PIN	3
23	CP-13-75	1/8" x .75" COTTER PIN	4
24	PP-31-3	5/16" x 3" CLEVIS PIN	1
25	HX-31-.75	5/16" HEX HEAD BOLT, .75"	2
26	LW-31	5/16" LOCK WASHER	2
27	HN-31	5/16" HEX HEAD NUT	2
28	HX-38-2	3/8" x 2" HEX HEAD BOLT	4
29	HX-38-1.25	3/8" x 1.25" HEX HEAD BOLT	4
30	80030	#50 CHAIN, 5 FT	1
31	K2525-1.5	1/4" SQR KEY, 1.5"	2
32	6N540481-NEA	48" PTO	1

REAR VIEW BREAKDOWN

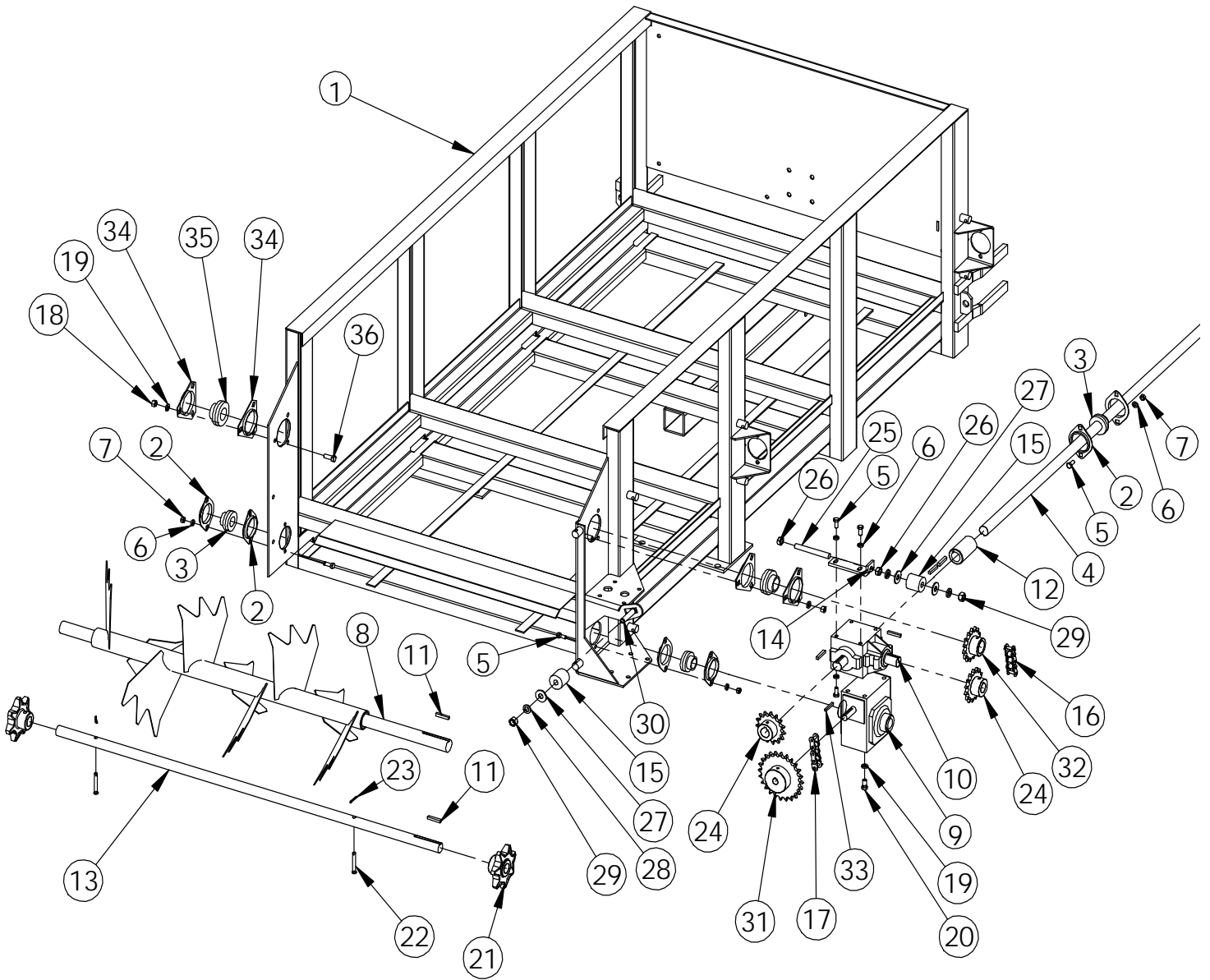

REAR VIEW PARTS LIST

ITEM NO.	PART NUMBER	DESCRIPTION	REAR/QTY.
1	50034	50 BUSHEL PTO FRAME	1
2	PFL-205	2-BOLT FLANGETTE, 1.00" BORE	6
3	SB205-16N	1" ID LOCKING BEARING	3
4	50032	1" DIA. SIDE SHAFT x 73.5"	1
5	HX-31-.75	5/16" HEX HEAD BOLT, .75"	12
6	LW-31	5/16" LOCK WASHER	12
7	HN-31	5/16" HEX HEAD NUT	6
8	80002	80 BUSHEL BEATER	1
9	0220-61017	212 WORM GEAR 50/1	1
10	R100-9AAF-B0157	R100 1/1 GEARBOX	1
11	K2525-1.5	1/4" SQR KEY, 1.5"	6
12	80022	1.00" COUPLING	1
13	80003	1" DIA. WEBB DRIVE SHAFT x 45.5"	1
14	80024	IDLER MOUNT	1
15	80023-A	1.50" DIA x 1.50" PLASTIC TIGHTENER	2
16	80031	#50 CHAIN, 2 FT	1
17	80032	#50 CHAIN, 3 FT	1
18	HN-38	3/8" HEX HEAD NUT	6
19	LW-38	3/8" LOCKWASHER	10
20	HX-38-.75	3/8" x .75" HEX HEAD BOLT	4
21	100-R36P	7 TOOTH CAST SPRKT, 1.00" BORE	2
22	PP-31-2.13	5/16" x 2.125" CLEVIS PIN	2
23	CP-13-75	1/8" x .75" COTTER PIN	2
24	5015W-1	50-15 SPROCKET 1" BORE	2
25	RR-50-4	1/2" REDI ROD	1
26	JN-50	1/2" JAM NUT	2
27	FW-50	1/2" FLAT WASHER	3
28	LW-50	1/2" LOCK WASHER	3
29	HN-50	1/2" HEX NUT	2
30	CH-50-2.5	1/2" CARRIAGE BOLT, 2.5"	1
31	5024X-.63	50-24 SPROCKET 0.63" BORE	1
32	5015W-1.25	50-15 SPROCKET 1.25" BORE	1
33	K1919-1.5	3/16" x 3/16" KEY, 1.5	1
34	PFT-206	3-BOLT FLANGETTE, 1.25" BORE	4
35	SB206-20N	1.25", LOCKING BEARING	2
36	HX-38-1	3/8" x 1" HEX HEAD BOLT	6

MINI SPREADER SLOP GATE KIT

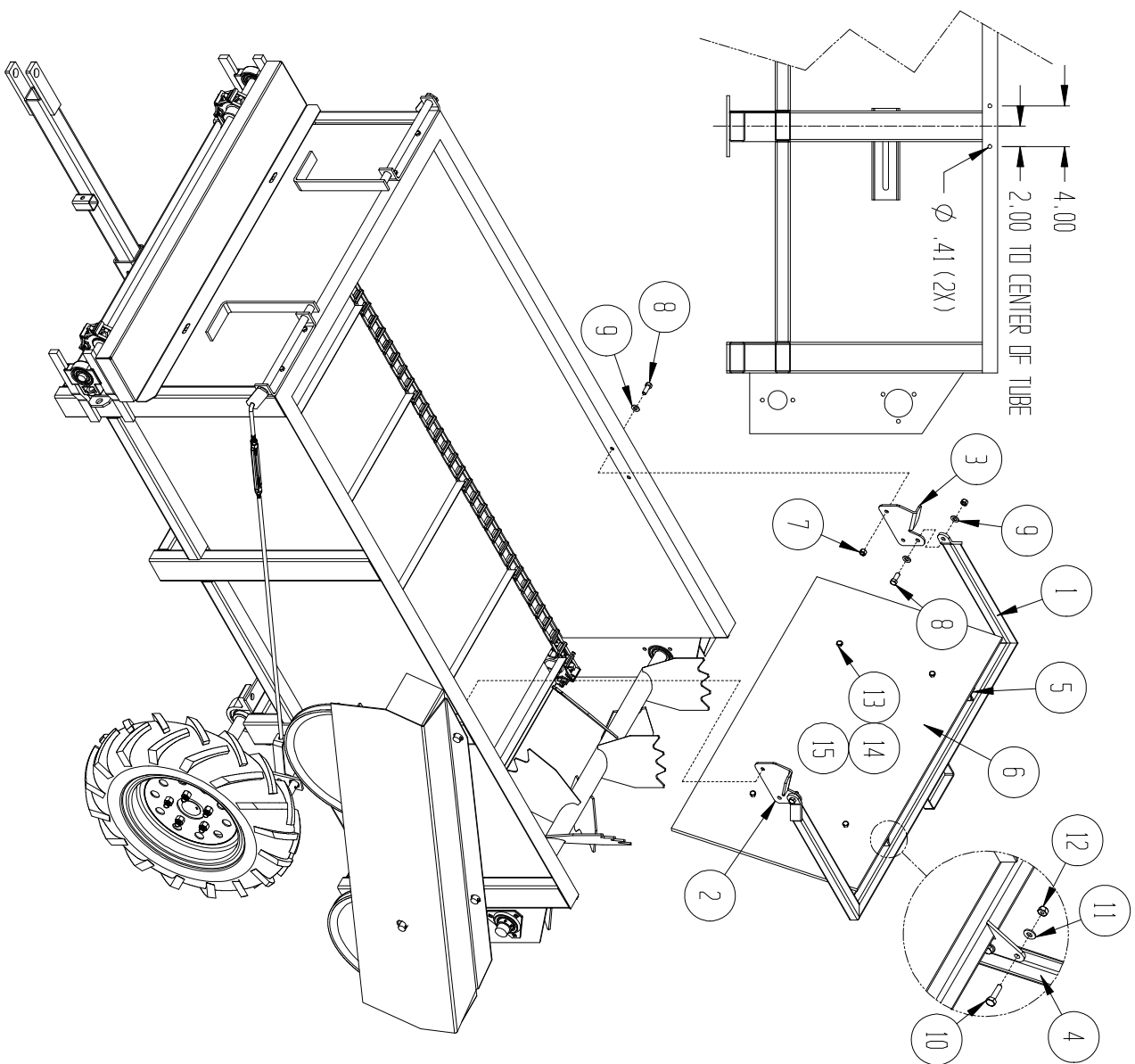

ITEM	PART #	DESCRIPTION	QTY
1	50024	50 BUSHEL SLOP GATE ARMS	1
	25045	25 BUSHEL SLOP GATE ARMS	-
2	50025	LEFT PIVOT BRACKET	1
3	50026	RIGHT PIVOT BRACKET	1
4	50027	LEFT 50 BUSHEL ANGLE MOUNT	1
	25046	LEFT 25 BUSHEL ANGLE MOUNT	-
5	50028	RIGHT 50 BUSHEL ANGLE MOUNT	1
	25047	RIGHT 25 BUSHEL ANGLE MOUNT	-
6	50029	50 BUSHEL PLASTIC	1
	25048	25 BUSHEL PLASTIC	-
7	HDW-246	.38 NYLON LOCKNUT	6
8	HDW-205	.38 X 1.25 HEX HEAD BOLT	6
9	HDW-257	.38 FLAT WASHER	8
10	HDW-266	.25 X .75 HEX HEAD BOLT	4
11	HDW-137	.25 LOCK WASHER	4
12	HDW-236	.25 HEX NUT	4
13	HDW-174	.31 X 1.25 CARRIAGE BOLT	4
14	HDW-138	.31 LOCK WASHER	4
15	HDW-237	.31 HEX NUT	4

RODA LIMITED WARRANTY

Roda Manufacturing Incorporation warrants, in accordance with the provisions below, to the original purchaser for the period of (12) months from the date of delivery of a Roda machine that the machine is free from defects in material or workmanship. Roda's obligation under this warranty is to repair or replace, at Roda's election, without charge and at the place of business of a dealer authorized to handle Roda machinery, any part or parts of the machine which, in the judgment of Roda, prove to be defective.

THIS WARRANTY AND RODAS OBLIGATION HEREUNDER IS IN LIEU OF ALL OTHER WARRANTIES, EXPRESSED OR IMPLIED, INCLUDING, WITHOUT LIMITATION, THE IMPLIED WARRANTY OF MERCHANTABILITY OR IMPLIED WARRANTY OF FITNESS FOR PARTICULAR PURPOSE, and all other obligations or liabilities of Roda for incidental and consequential damages resulting from the design, manufacture, sale or use of the machine. No person is authorized to make any warranty or assume for Roda any liability not strictly in accordance with this warranty.

This warranty shall not apply to any machine or machine part which, in the judgment of Roda, has been altered or tampered with in any way or has been subjected to misuse, abuse, neglect or accident, or has had the serial numbers altered, effaced or removed. This warranty does not apply to batteries, tire and tubes, or other component parts not manufactured by Roda, except to the extent of their individual manufacturer's guarantees. Any and all such parts must be returned to the original manufacturer for warranty adjustment.

Roda Manufacturing Incorporation reserves the right to make improvements or changes when it becomes practical and possible to do so, without incurring any obligations to make changes or additions to the equipment sold previously.

WARRANTY REGISTRATION SHEET

MODEL NUMBER _____

SERIAL NUMBER _____

DATE OF SALE _____

CUSTOMER _____

DEALER _____

ADDRESS _____

ADDRESS _____

CITY _____

CITY _____

STATE _____ ZIP _____

STATE _____ ZIP _____

This is to acknowledge that I am the new owner of the following RODA Machine, that I agree to read the Operators manual and become familiar with the safe operation of this unit.

_____ R25 _____ R50 _____ R50 PTO _____ R80 _____ R210 _____ R410 _____ R610 _____ R810
_____ RF812 _____ RF912 _____ R716 _____ R720 _____ R716F _____ R720F

Roda Manufacturing Incorporation warrants, in accordance with the provisions below, to the original purchaser for the period of (12) months from the date of delivery of a Roda machine that the machine is free from defects in material or workmanship. Roda's obligation under this warranty is to repair or replace, at Roda's election, without charge and at the place of business of a dealer authorized to handle Roda machinery, any part or parts of the machine which, in the judgment of Roda, prove to be defective.

THIS WARRANTY AND RODAS OBLIGATION HEREUNDER IS IN LIEU OF ALL OTHER WARRANTIES, EXPRESSED OR IMPLIED, INCLUDING, WITHOUT LIMITATION, THE IMPLIED WARRANTY OF MERCHANTABILITY OR IMPLIED WARRANTY OF FITNESS FOR PARTICULAR PURPOSE, and all other obligations or liabilities of Roda for incidental and consequential damages resulting from the design, manufacture, sale or use of the machine. No person is authorized to make any warranty or assume for Roda any liability not strictly in accordance with this warranty.

This warranty shall not apply to any machine or machine part which, in the judgment of Roda, has been altered or tampered with in any way or has been subjected to misuse, abuse, neglect or accident, or has had the serial numbers altered, effaced or removed. This warranty does not apply to batteries, tire and tubes, or other component parts not manufactured by Roda, except to the extent of their individual manufacturer's guarantees. Any and all such parts must be returned to the original manufacturer for warranty adjustment.

Roda Manufacturing Incorporation reserves the right to make improvements or changes when it becomes practical and possible to do so, without incurring any obligations to make changes or additions to the equipment sold previously.

SIGNED _____

DATE _____

This Registration form Must be returned to enact this warranty.