

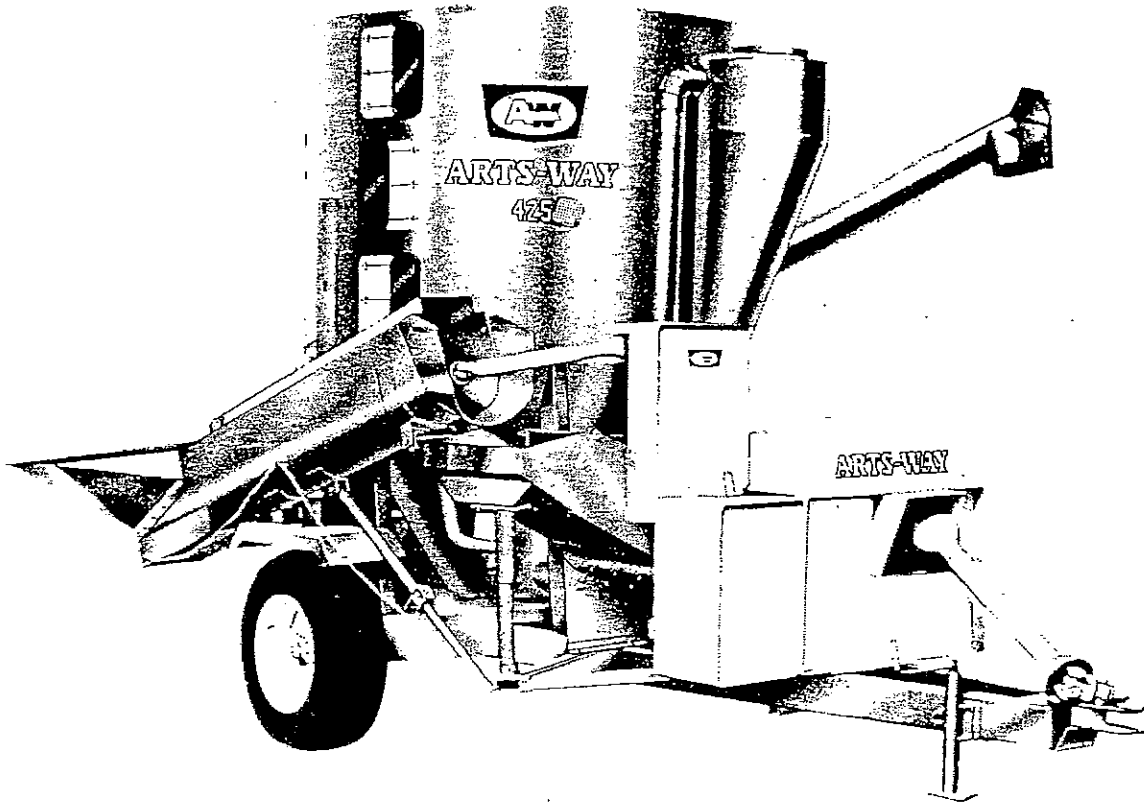

ARTS-WAY

OPERATORS MANUAL & PARTS LIST SUPPLEMENT



MODEL 425-C & 325-C

FEED MIXER AND MILL

REV. 10-75

3.65M



ARTS-WAY

Mfg. Company / Armstrong, Iowa / Phone (712) 864-3131

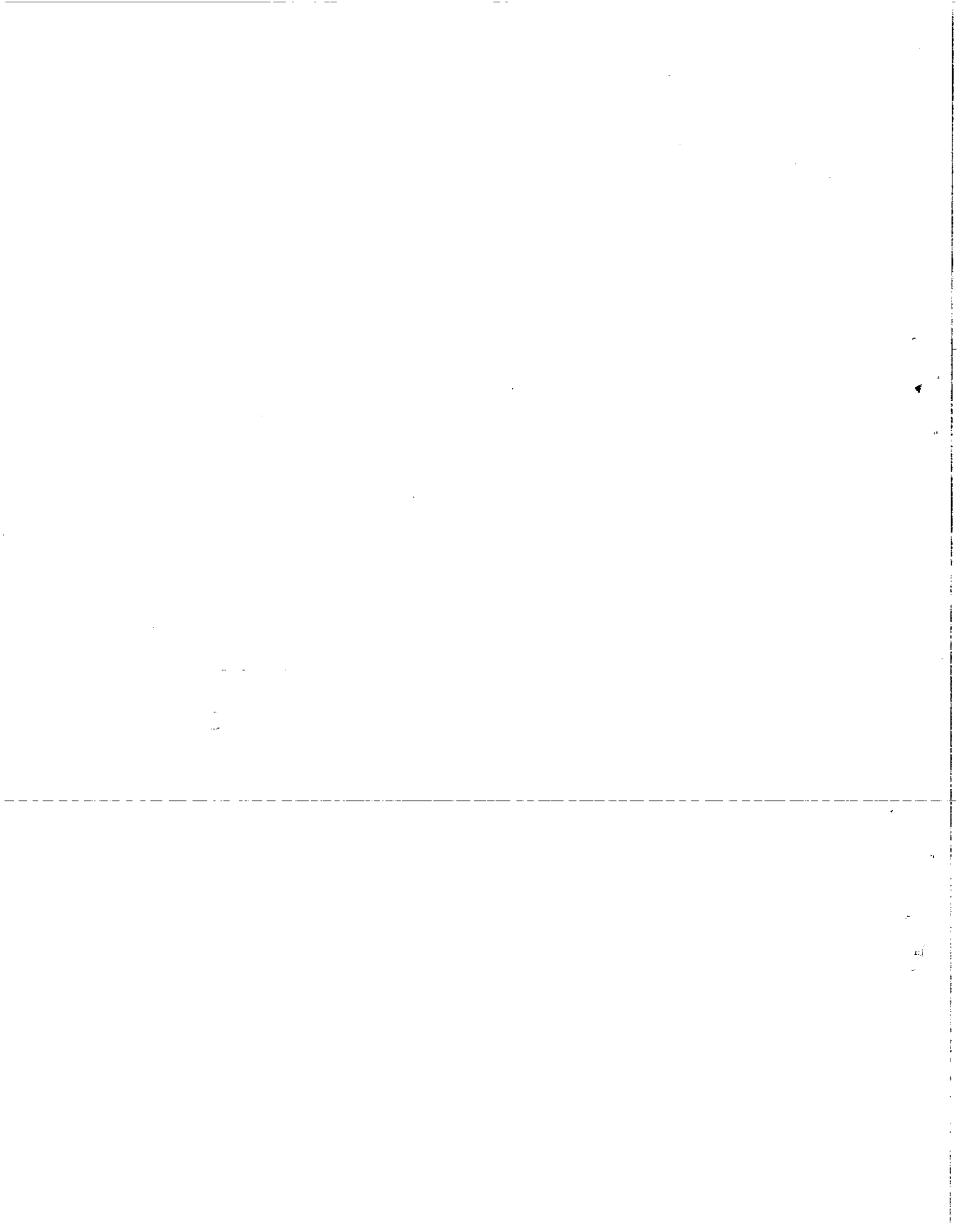

This manual has been prepared to help you understand your new machine and to identify the parts which make it function.

This manual is a supplement to the Model 425-B and 325-B Operators Manual and Parts List. In this supplement manual is a list of the latest engineering revisions which make up your 425-C or 325-C Portable Feed Mixer and Mill. Both, this manual and the 425-B and 325-B should be retained and thoroughly read before operating your 425-C and 325-C Feed Mixer and Mill.

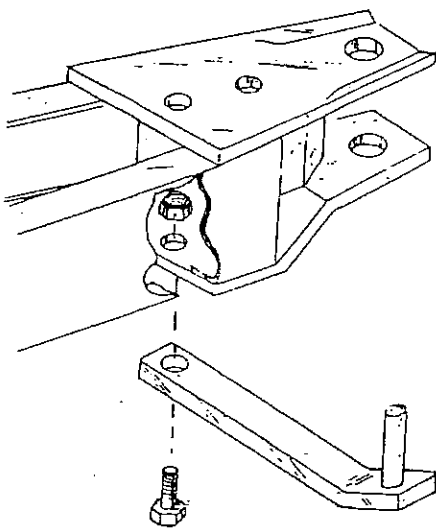

CAUTION! Remove front PTO half when towing with pickup. Swing PTO holder to rear and hold in place with jack in transport position.

322-03754 Nut, ½-13 UNC Nylon Lock
215-10831 P. T. O. Holder
303-01477 Bolt ½-13 UNC x 1½ Hex

This part is a new improvement to your machine. It is bolted through the back hole in the bottom hitch plate. It holds the P. T. O. Shaft when not in use.

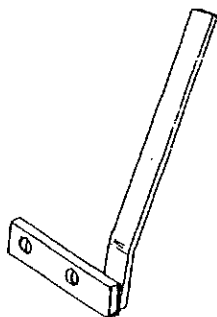

109-10521 Clutch Handle

This handle is an improvement which replaces item 32 on Page 46 of the Model 425-B & 325-B manual.

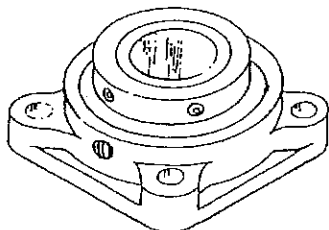

301-02027 Bearing 1 5/8 Flange

This bearing is the same bearing as item 5 on Page 42 of the Model 425-B & 325-B manual, except it doesn't need to be greased. Therefore item 2 is omitted.

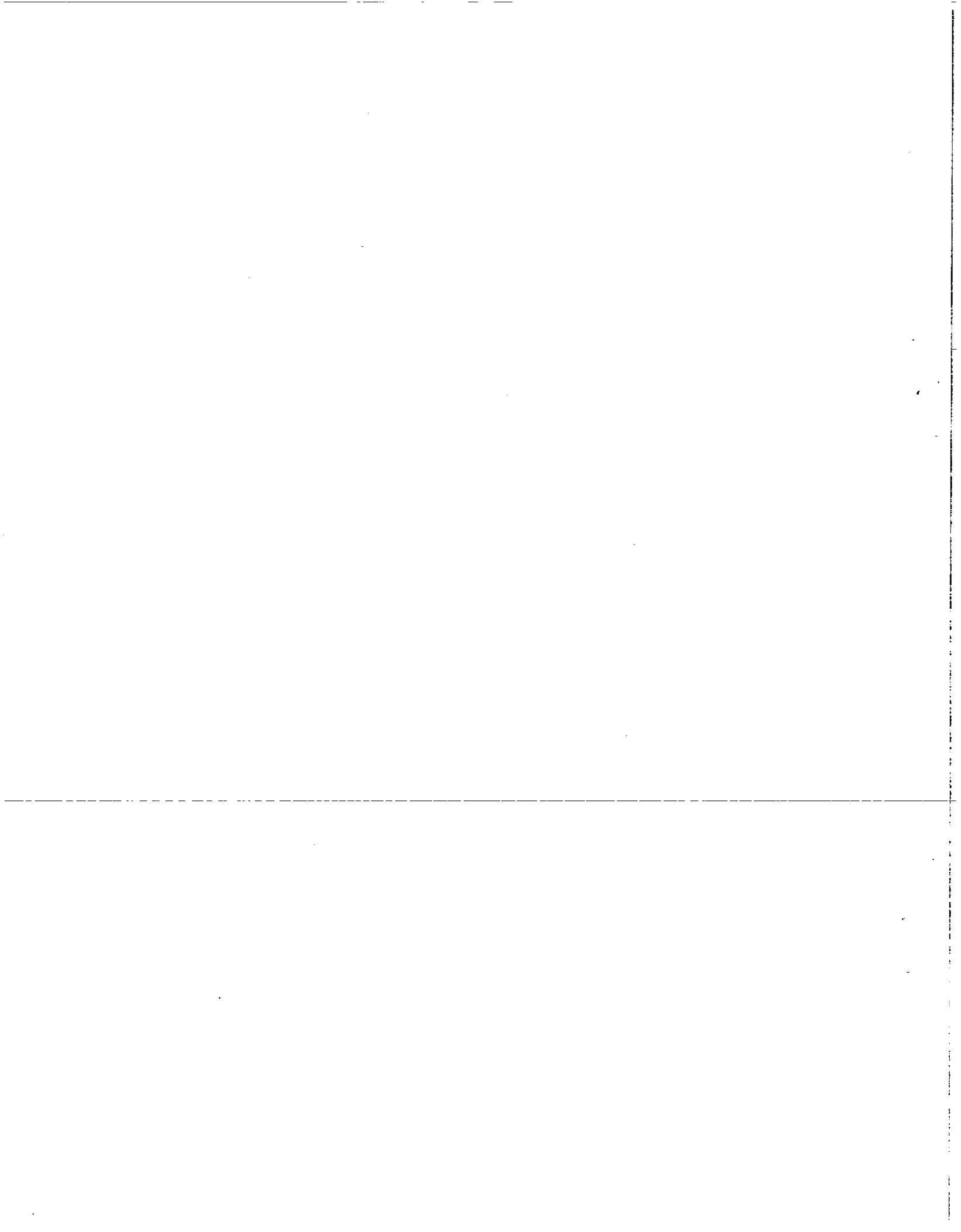

JACK ASSEMBLY

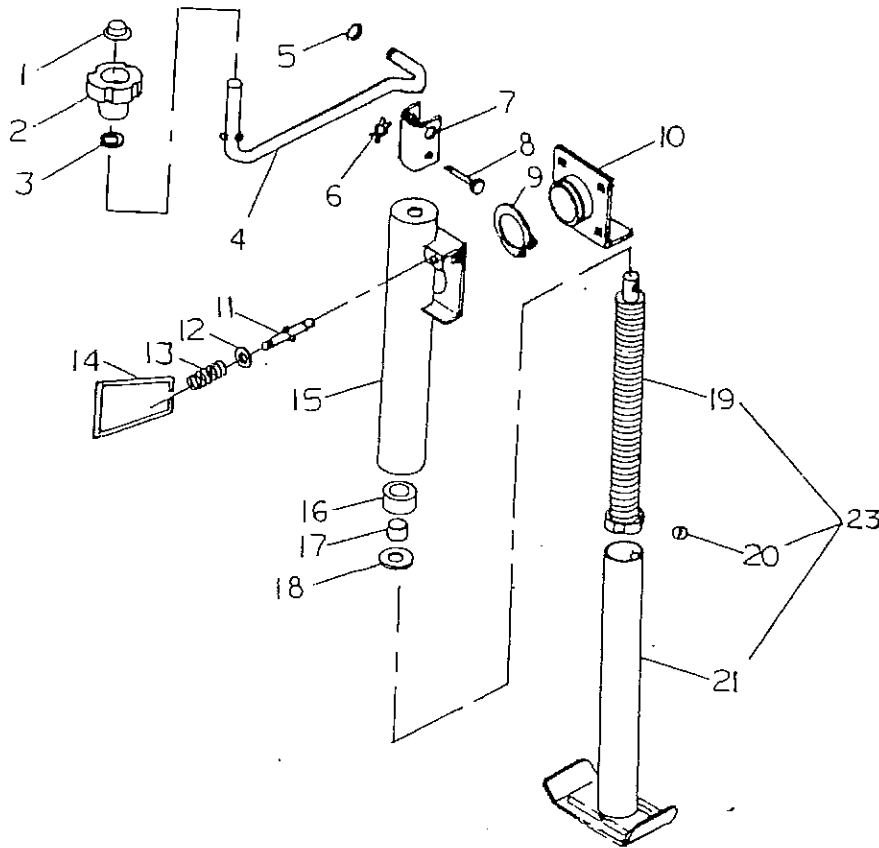

Key	Part Number	Description
1	303-04023	Spring Steel Grip Keeper
2	315-04024	Swivel Grip For Handle
3	340-04025	Washer, 1/2" Flat (ZN)
4	415-04026	Handle For Swivel Jack
5	340-04027	"C" Washer Holds Jack Crank
6	340-04032	"X" Washer Holds Crank Pin
7	321-04028	Sleeve, For Jack Crank Handle
8	323-04033	Crank Handle Pin
9	335-04029	Snap Ring Heavy Duty
10	404-04030	Jack Bracket Welds To Frame
11	423-04031	Lock Pin Plunger
12	340-04034	Washer, 1/2" Flat (ZN)
13	438-04035	Lock Pin Plunger Spring
14	435-04036	Pull Ring For Lock Pin
15	418-04037	Jack Top Assembly
16	301-04038	Jack Thrust Bearing
17	405-04039	Nylon Bushing
18	340-04040	Thrust Bearing Washer
19	431-04041	Screw Rack Assembly
20	330-04042	Ball, Rack Keeper
21	418-04043	Jack Bottom Assembly
22	418-04044	Complete Jack Assembly
23	418-04408	Bottom Half Screw and Foot Assembly

This Page Supersedes Page 13 of Model 425-B & 325-B Manual

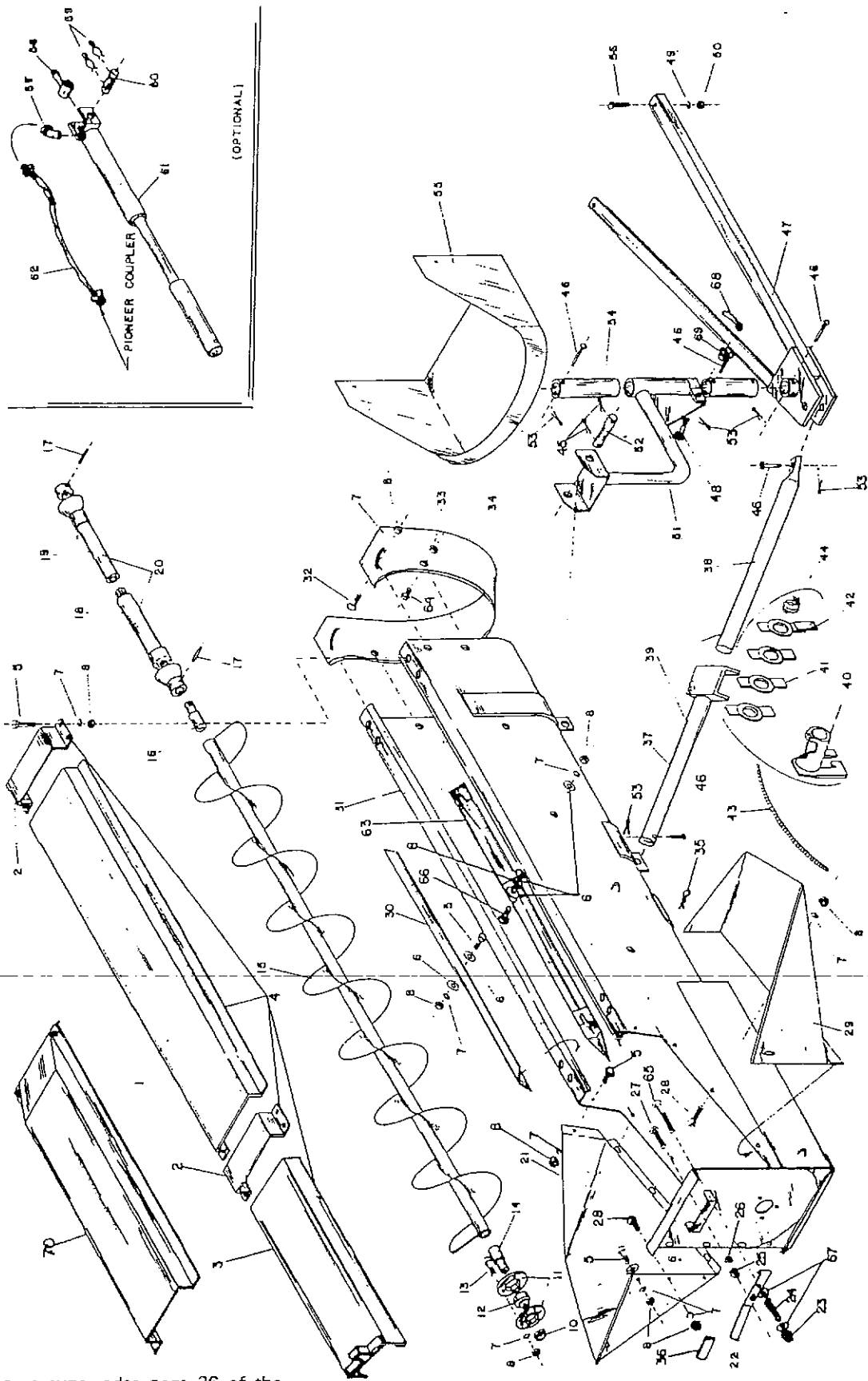

This page supersedes page 36 of the Model 425-B & 325-B manual.

MECHANICAL AUGER FEEDER

Key	Part Number	Description
1	133-10026	Safety Shield
2	104-10025	Bracket
3	233-10029	Sliding Safety Shield
4	220-10561	Safety Shield Kit (4 pieces plus necessary hardware)
5	303-01214	Bolt 5/16 X 3/4 Hex Hd. (GR-5 ZN)
6	303-02292	Washer 5/16 Flat (ZN)
7	340-02362	Washer 5/16 Lock (ZN)
8	322-02363	Nut 5/16 Hex (ZN)
9	303-00688	Bolt 5/16-18 UNC X 5/8 Hex (GR-5 ZN)
10	301-01230	Collar Only for 1" Bearing
11	101-01233	Flange for 1" Bearing
12	301-01231	1" Bearing Only
13	303-00590	Bolt 5/16 X 1 Hex (GR-5 ZN)
14	132-01532	Plug Bottom 1"
15	232-01405	10" Auger for 7' Feeder
16	132-01533	Plug, Top 1"
17	323-01401	Expanspin 5/16 X 1 5/8 (ZN)
18	426-01502	Power Shaft Half-Attaches to Auger
19	426-01501	Power Shaft Half-Attaches to Drive
20	426-01503	Complete Power Shaft for Auger Feeder
21	233-01515	Left Side of Bottom Hopper Panel
22	109-04238	Release Handle Hopper
23	322-04237	Nut 1/4-20 UNC Self Lock Hex. All Metal (ZN)
24	438-04239	Spring 1/2 O.D. X 1" Long, Compression
25	322-02766	Nut 1/4-20 UNC Hex (ZN)
26	340-02944	Washer 1/4 lock (ZN)
27	303-04240	Bolt 1/4-20 UNC X 7/8 Truss Hd. (GR-5 ZN)
28	303-02823	Bolt 5/16-18 UNC X 3/4 Truss Hd. (GR-5 ZN)
29	233-04241	Right Side Folding Hopper Panel w/Hinge
30	142-02139	Angle for Left Side of Feeder
31	216-10038	Auger Feeder Housing (Includes 2 Brackets 104-10025)
32	303-03332	Bolt 5/16-18 UNC X 3/4 Step Carriage (GR-5 ZN)
33	322-02567	Nut 5/16-18 UNC Self Lock Hex (ZN)
34	133-01506	Downspout
35	323-03583	Hair Pin 3/16 X 3
36	412-05015	Grip for Release Handle
37	218-01413	Top Support Pipe of Jack
38	118-01415	Bottom Support Pipe of Jack
39	218-01519	Complete Jack Support
40	206-01414	Clamp for Jack (complete w/spring feeder & washer)
41	540-01536	Washer-Set of 4 Clamping
42	240-03584	1 Clamping Washer w/Hole for Rope (ZN)
43	142-01899	Polypropylene Rope 7'-5" X 3/16" Yellow
44	338-01520	Spring for Clamp
45	319-03585	Cotter Pin 5/32 X 1 1/4 (ZN)
46	323-02142	Clevis Pin 3/8 X 2 3/4 (ZN)
47	204-01511	Bottom Support for Swivel Unit (A Frame)
48	303-99077	Bolt 7/16 -14 UNC X 1 1/2 Carriage (GR-1 ZN)
49	340-00537	Washer 1/2 Lock (ZN)
50	322-00536	Nut 1/2-13 UNC Hex (ZN)
51	204-10000	Support Swivel
52	129-01512	Rod 3/4" X 10"
53	319-03436	Cotter Pin 1/8 X 1 (ZN)
54	124-03664	Vertical Post
55	216-03663	Hopper for Mill
56	303-00539	Bolts 1/2-13 Unc X 1 Carriage (GR-5 ZN)
57	324-00649	45° Street Elbow
58	204-04341	Lower Mounting Bracket
59	319-03712	Hair Pin
60	423-03711	Pin, Hydraulic Arm Support
61	417-04342	Prince Cylinder 14" Stroke
62	417-04343	Hose 1/2" X 11" Long 1 1/2" Pioneer Coupler & a 1/2" Swivel Connector
63	242-01505	Angle for Right Side of Feeder
64	303-00688	Bolt 5/16-18 UNC X 5/8 Hex (GR-5 ZN)
65	303-04406	Bolt 1/4-20 UNC X 1-1/2 Truss Hd (GR-5 ZN)
66	303-04929	Bolt 5/16 -18 UNC X 1 1/2 Carriage (GR-5 ZN)
67	340-02326	Washer 1/4 Flat (ZN)
68	303-01310	7/16-14 UNC Handle Nut
69	136-10832	Spacer, Drag Clamp
70	233-10643	Shield, Auger Safety, for Hydraulic Drag Feeder

This Page Supersedes Page 37 of Model 425-B & 325-B Manual

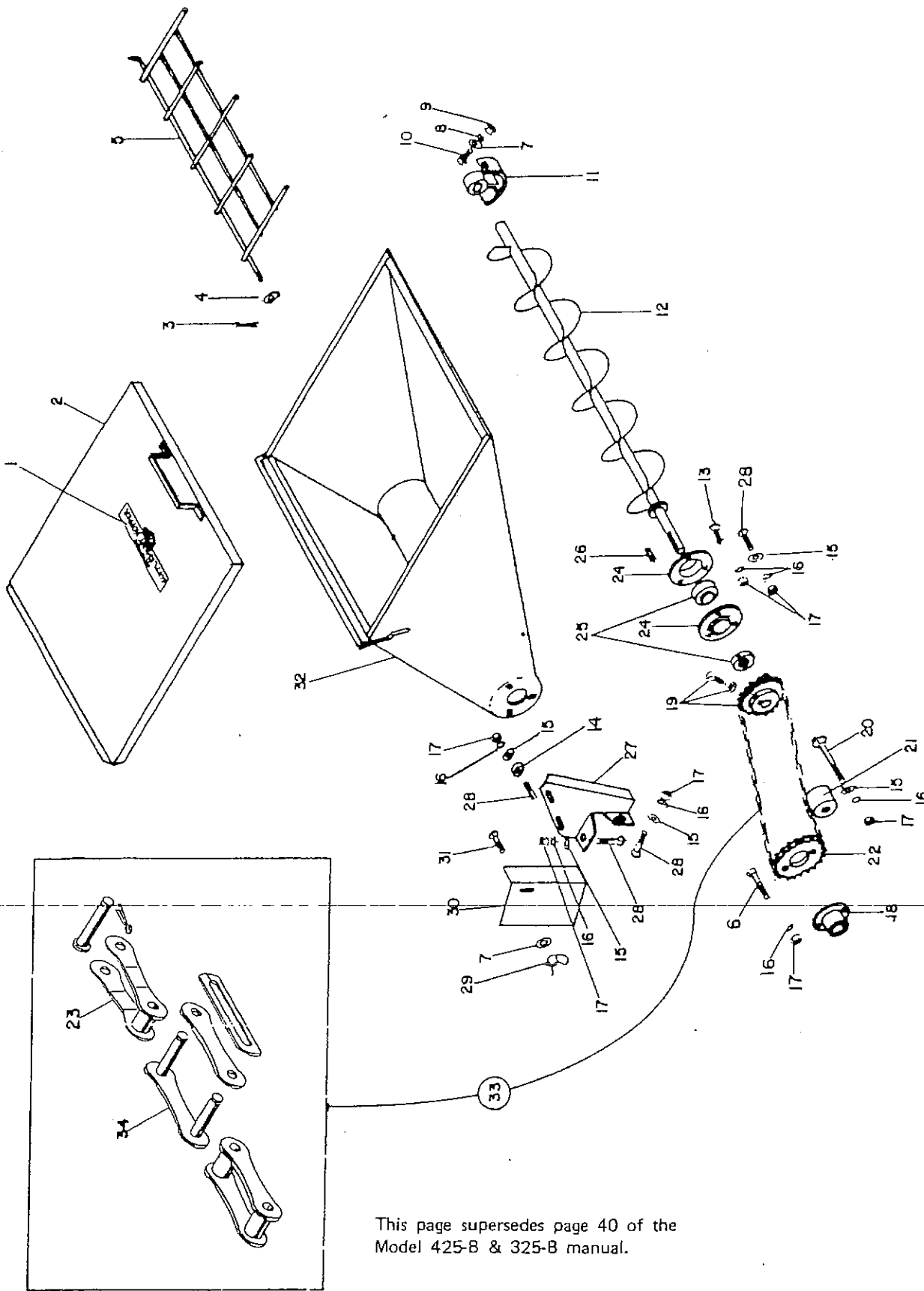

This page supersedes page 40 of the Model 425-B & 325-B manual.

SUPPLEMENT HOPPER

Key	Part Number	Description
1	442-02117	Decal, Supplement Hopper
2	233-19009	Lid, Supplement Hopper
3	323-02121	Cotter Pin 3/32 X 1 (ZN)
4	340-02326	Washer 1/4 Flat (ZN)
5	242-10398	Grate
6	303-00669	Bolt, 3/8-16 UNC X 1 1/4 Hex (GR-5 ZN)
7	303-02292	Washer 5/16 Flat (ZN)
8	340-02362	Washer 5/16 Lock (ZN)
9	322-02363	Nut 5/16-18 UNC Hex (ZN)
10	303-01214	Bolt 5/16-18 UNC X 3/4 Hex (GR-5 ZN)
11	501-02116	Nylon "T" Bearing
12	245-04149	Auger
13	303-02017	Bolt 3/8-16 UNC X 1 Carriage (GR-5 ZN)
14	336-03346	Spacer 3/8 I.D. X 9/16 O.D. X 9/32 Long
15	303-02119	Washer 3/8 Flat (ZN)
16	303-02118	Washer 3/8 Lock (ZN)
17	322-02726	Nut 3/8-16 UNC Hex (ZN)
18	210-02008	Shear Hub 1 1/4 Bore
19	537-02024	Sprocket 40B28 1 1/8 Bore w/set Screw 5/16-18 UNC & Nut
20	303-03554	Bolt 3/8-16 UNC X 2 3/4 Carriage (GR-5 ZN)
21	442-02126	Block, Oil Treated Wood
22	437-03920	Sprocket 40A28 1 1/4 Bore
23	308-01338	Offset Link 2040 with Pin & Cotter
24	101-01915	Flange for 1 1/8 Bearing
25	301-10885	Bearing 1 1/8 & Collar
26	119-02125	Key 5/16 Sq. X 1
27	112-03535	Bracket, Supplement Hopper Support
28	303-03518	Bolt 3/8-16 UNC X 1 1/4 Carriage (ZN)
29	322-00979	Nut 5/16-18 UNC Wing (ZN)
30	133-03623	Shield, Hopper Drive
31	303-01241	Bolt 5/16-18 UNC X 3/4 Carriage (GR-5 ZN)
32	216-10021	Supplement Hopper
33	308-03537	Chain 2040, 41 Pitches, 1 Offset, 2 Connectors Incl.
34	308-01339	Connector Link 2040

This Page Supersedes Page 41 of Model 425-B & 325-B Manual

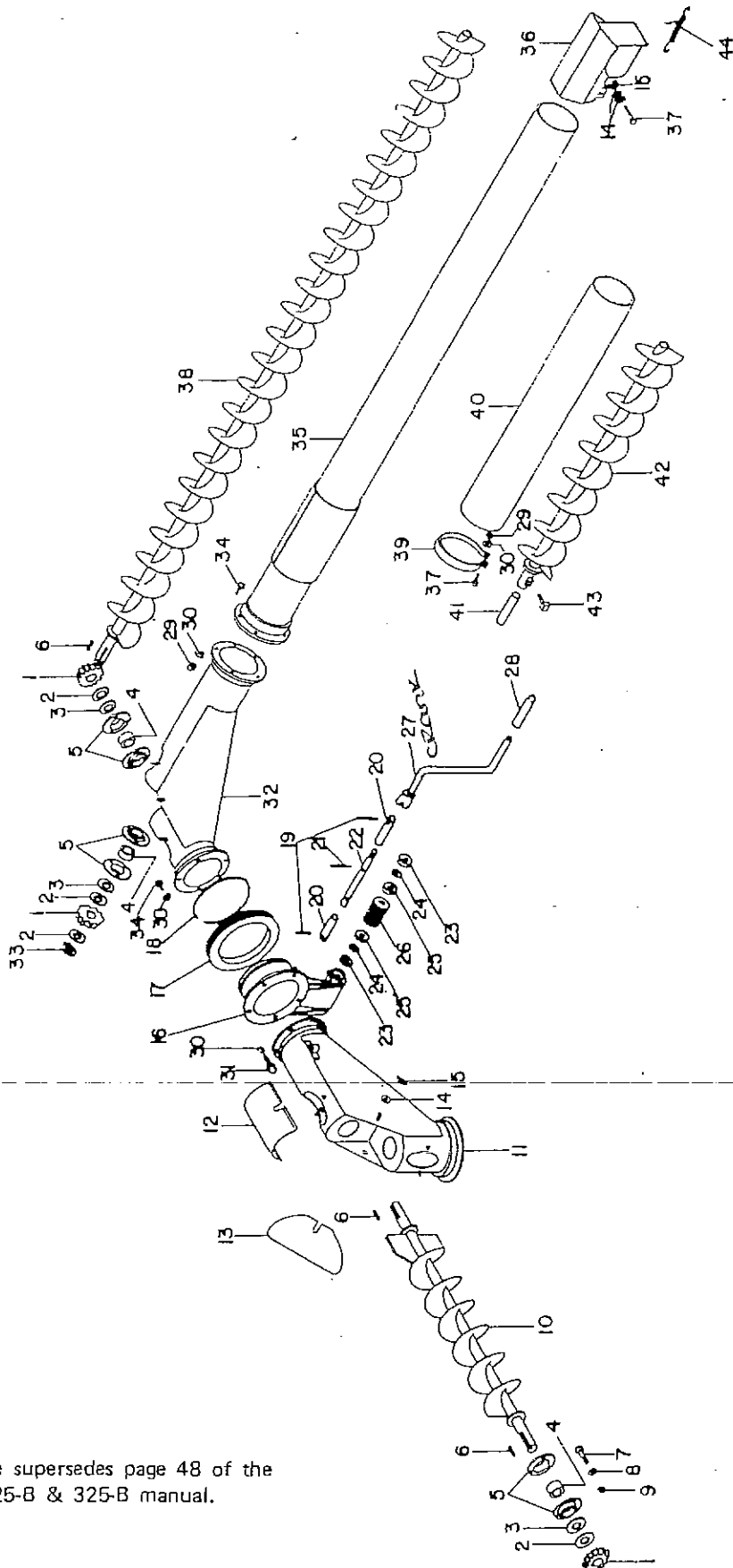

This page supersedes page 48 of the Model 425-B & 325-B manual.

DISCHARGE AUGER TOP UNIT

Key	Part Number	Description
1	514-02058	Bevel Gear 1 1/8 Bore
2	140-02065	Washer 1 1/2 I.D. X 1 5/8 O.O. X 10 GA
3	140-02075	Washer 1 1/8 I.D. X 1 5/8 O.O. X 12 GA
4	301-02023	Bearing Only 1 1/8 Bore
5	101-01915	Flange
6	119-02076	Key 5/16 Sq. X 1 1/8
7	303-02017	Bolt 3/8-16 UNC X 1" Carriage (GR-5 ZN)
8	303-02118	Washer 3/8 Lock (ZN)
9	322-02726	Nut 3/8-16 UNC Hex (ZN)
10	245-04085	Cross Auger 7" 1 1/8 Shaft
11	216-04086	Discharge Tube Elbow 8"
12	133-01252	Clean Out Door
13	133-04087	Bevel Gear Shield
14	303-02292	Washer 5/16 Flat (ZN)
15	322-00979	Nut 5/16-18 UNC Wing (ZN)
16	216-10439	Holder Assy.
17	514-10070	Ring Gear
18	435-10436	Snap Ring (2 req'd) one on each side of ring gear
19	323-01255	Expanpin 1/4 X 1 1/4 (ZN)
20	136-10441	Sleeve
21	323-01256	Expanpin 3/16 X 1 (ZN)
22	132-10516	Shaft
23	301-10437	Bearing, Ball 5/8" Bore
24	140-03519	Washer 5/8 I.D. X 1 O.O. X 14 Ga., Thrust
25	301-01258	Bearing 5/8 Thrust
26	414-10069	Worm
27	2D9-01250	Crank
28	342-02064	Grip for Crank
29	322-02363	Nut 5/16-18 UNC Hex (ZN)
30	340-02362	Washer 5/16 Lock (ZN)
31	303-00688	Bolt 5/16-18 UNC X 5/8 Hex (GR-5 ZN)
32	216-10449	Elbow, Discharge Tube 8"
33	335-03520	Snap Ring 1 1/8
34	303-01214	Bolt 5/16-18 UNC X 3/4 Hex (GR-5 ZN)
35	216-04098	Tube 79" (Standard)
	216-04099	Tube 91" (1' Ext.)
	216-04100	Tube 103" (2' Ext.)
	216-04101	Tube 115" (3' Ext.)
36	216-10291	Unloading Auger Hood
37	303-03003	Bolt 5/16-18 UNC X 1 1/4 Hex (GR-5 ZN)
38	245-04094	Auger 7" With 95" Shaft (Standard)
	245-04095	Auger 7" With 107" Shaft (1' Ext.)
	245-04096	Auger 7" With 119" Shaft (2' Ext.)
	245-04097	Auger 7" With 131" Shaft (3' Ext.)
39	106-04114	Band, Extension Holding
40	116-04103	Tube 2' Extension
	116-04104	Tube 3' Extension
	116-04105	Tube 4' Extension
	116-04106	Tube 5' Extension
	116-04107	Tube 7' Extension
41	132-04113	Shaft 1 1/8"
42	245-04108	Auger 2' Extension
	245-04109	Auger 3' Extension
	245-04110	Auger 4' Extension
	245-04111	Auger 5' Extension
	245-04112	Auger 6' Extension
43	303-00878	Set Screw 7/16 X 4 UNC X 3/4 Sq. Hd. (ZN)
44	438-10075	Spring for Auger Hood

This Page Supersedes Page 49 of Model 425-8 & 325-8 Manual

