



## **Art's-Way Manufacturing Co., Inc.**

**CATTLEMAXX**  
Models 5105 And 5165

**Operator's Manual**  
560520

**Issued 07-07**

**O P E R A T O R ' S M A N U A L**



*This symbol means **ATTENTION! BECOME ALERT! YOUR SAFETY IS INVOLVED.** The message that follows the symbol contains important information about your safety. Carefully read the message. Make sure you fully understand the causes of possible injury or death.*

IF THIS MACHINE IS USED BY AN EMPLOYEE, IS LOANED, OR IS RENTED, MAKE SURE THAT THE OPERATOR UNDERSTANDS THE TWO INSTRUCTIONS BELOW.

**BEFORE THE OPERATOR STARTS THE ENGINE:**

1. GIVE INSTRUCTIONS TO THE OPERATOR ABOUT SAFE AND CORRECT USE OF THE MACHINE.
2. MAKE SURE THE OPERATOR READS AND UNDERSTANDS THE OPERATOR'S MANUAL FOR THIS MACHINE.

## **WARNING**

IMPROPER OPERATION OF THIS MACHINE CAN CAUSE INJURY OR DEATH.

**BEFORE STARTING THE ENGINE, DO THE FOLLOWING:**

1. READ THE OPERATOR'S MANUAL.
2. READ ALL SAFETY DECALS ON THE MACHINE.
3. CLEAR THE AREA OF OTHER PERSONS.

LEARN AND PRACTICE SAFE USE OF MACHINE CONTROLS IN A SAFE AND CLEAR AREA BEFORE YOU OPERATE THIS MACHINE ON A JOB SITE.

It is your responsibility to observe pertinent laws and regulations and to follow manufacturer's instructions on machine operation and maintenance.

See your Authorized Art's-Way Manufacturing Co., Inc. dealer or Art's-Way Manufacturing Co., Inc. for additional operator's manuals, illustrated parts catalogs, and service manuals.

## TO THE OWNER

Congratulations on the purchase of your new Art's-Way CattleMaxx. You have selected a top quality machine that is designed and built with pride to ensure you have many years of efficient and reliable service.

Many people have worked on the design, production, and delivery of this CattleMaxx. The information in this Manual is based on the knowledge, study, and experience through years of specializing in the manufacturing of farm machinery. This Manual is designed to provide you with important information regarding safety, maintenance, and machine operation so you can and will get the best possible performance from your CattleMaxx.

Even if you are an experienced operator of this or similar equipment, we ask that you **read this manual before operating the CattleMaxx.** The way you operate, adjust, and maintain this unit will have much to do with its successful performance. Any further questions you may have about this product of Art's-Way equipment should be directed to your local Art's-Way dealer or to Art's-Way Manufacturing Co., Inc., Armstrong, Iowa, 50514, (712) 864-3131.

### **SPECIFICATIONS AND DESIGN ARE SUBJECT TO CHANGE WITHOUT NOTICE**

Art's-Way Manufacturing Co., Inc. is continually making product improvements. In doing so, we reserve the right to make changes and/or add improvements to our products without obligation for the equipment previously sold.

Modifications to this CattleMaxx may affect the performance, function, and safety of its operation. Therefore, no modifications are to be made without the written permission of Art's-Way Manufacturing Co., Inc. Any modification made without the written permission of Art's-Way Mfg. Co. shall void the warranty of this product.

In the interest of continued safe operation of this CattleMaxx, pay particular attention to the safety alert symbol(s) throughout this Manual.

### **ART'S-WAY MANUFACTURING CO., INC. STATEMENT OF PRODUCT LIABILITY**

Art's-Way Manufacturing Co., Inc. recognizes its responsibility to provide customers with a safe and efficient product. Art's-Way Manufacturing Co., attempts to design and manufacture its products in accordance with all accepted engineering practices effective at the date of design. This statement should not be interpreted to mean that our products will protect against the user's own carelessness or failure to follow common safety practices nor will Art's-Way Manufacturing Co., be liable for any such act. In addition, Art's-Way Manufacturing Co. assumes no liability for any altered product or any modified product by users or anyone other than an authorized dealer.

### **IMPORTANT WARRANTY INFORMATION**

The warranty for this CattleMaxx appears on page 3 of this Manual. In order to establish proper warranty registration, the Warranty Registration must be completed and returned to the factory. Failure to comply with this requirement may result in reduced warranty allowances.

### **LIMITATIONS OF THIS MANUAL**

This Manual contains operating instructions for your CattleMaxx only. Any mention of other machinery in this manual other than the CattleMaxx is for reference only. This manual does not replace nor is it to be used for any machinery that may be attached to or used in conjunction with the CattleMaxx.

# PARTS & SERVICE

As the purchaser of your new CattleMaxx, it is very important to consider the following factors:

- A. Original Quality**
- B. Availability of Service Parts**
- C. Availability of Adequate Service Facilities**

Art's-Way Manufacturing Co., Inc. has an excellent dealership network ready to answer any questions you may have about your CattleMaxx. Parts for your machine may be ordered through our dealers. When placing a parts order, please have the **model** and **serial number** ready. This will allow the dealer to fill your order as quickly as possible.

For your convenience, we have provided this space for you to record your model number, serial number, and the date of purchase, as well as your dealer's name and address.

Owner's Name: \_\_\_\_\_

Owner's Address: \_\_\_\_\_

Purchase Date: \_\_\_\_\_

Dealership Name: \_\_\_\_\_

Dealership Address: \_\_\_\_\_

Dealership Phone No.: \_\_\_\_\_

### CattleMaxx Serial Number Location

The placard containing the serial and model number is located on the front left-hand side of the CattleMaxx. Enter the serial and model number of your CattleMaxx within the space provided.

Figure 2 - Serial Number Placard.



Figure 1 - Serial Number Placard Location.

# TABLE OF CONTENTS

<b>TO THE OWNER .....</b>	<b>1</b>	UNLOADING AUGER ENGAGEMENT .....	24
SPECIFICATIONS AND DESIGN ARE SUBJECT TO CHANGE WITHOUT NOTICE.....	1	UNLOADING CLUTCH DRIVE .....	24
ART'S-WAY MANUFACTURING CO., INC. STATEMENT OF PRODUCT LIABILITY .....	1	FOLDING AUGER EXTENSION .....	24
IMPORTANT WARRANTY INFORMATION.....	1	UNLOADING AUGER HOOD.....	24
LIMITATIONS OF THIS MANUAL .....	1	AUGER FEED OPERATION.....	25
<b>PARTS &amp; SERVICE.....</b>	<b>2</b>	<b>GRINDER MIXER ADJUSTMENTS.....</b>	<b>28</b>
<b>TABLE OF CONTENTS .....</b>	<b>3</b>	DRIVE CHAIN ADJUSTMENTS.....	28
<b>LIMITED WARRANTY .....</b>	<b>4</b>	MAIN DRIVE CHAIN .....	28
<b>SAFETY FIRST.....</b>	<b>5</b>	ROLL SPEED DIFFERENTIAL .....	28
NOTICES OF DANGER, WARNING, AND CAUTION .....	5	ROLL GAP.....	28
<b>SAFETY GUIDELINES.....</b>	<b>6</b>	ROLL PARALLELISM .....	29
BEFORE OPERATING .....	6	ROLL SCRAPERS .....	29
DURING OPERATION .....	6	MANUAL UNLOADING AUGER SWING CRANK	
MAINTENANCE SAFETY .....	6	ADJUSTMENT FOR SPROCKET ENGAGEMENT.....	30
HYDRAULIC SAFETY .....	7	MANUAL UNLOADING AUGER SWING BRAKE	
TRANSPORTATION SAFETY .....	7	ADJUSTMENT .....	30
STORAGE SAFETY .....	7	MANUAL LIFT ADJUSTMENT .....	30
TIRE SAFETY .....	7	HYDRAULIC SWING DRIVE ADJUSTMENT .....	30
ASSEMBLY SAFETY.....	8	HYDRAULIC SWING SPEED ADJUSTMENT.....	31
<b>SAFETY DECALS .....</b>	<b>9</b>	LIFT ASSIST SPRING ADJUSTMENT .....	31
DECAL LOCATIONS & IDENTIFICATION.....	9	POSITIONING THE UNLOADING AUGER TO OPPOSITE	
<b>INTRODUCTION.....</b>	<b>12</b>	SIDE OF MACHINE .....	31
<b>PREPARING THE CATTLEMAX FOR OPERATION.....</b>	<b>14</b>	SWIVEL STOP ADJUSTMENT.....	32
TIRES.....	14	OPEN AND CLOSED HYDRAULICS.....	32
SHIELDS.....	14	CONVERTING TO CLOSED CENTER HYDRAULICS.....	32
BOLTS AND NUTS .....	14	WHEEL BEARINGS .....	32
PREPARING THE TRACTOR.....	15	<b>LUBRICATION.....</b>	<b>33</b>
TRACTOR HITCH .....	15	PTO DRIVELINE .....	33
ATTACHING TO THE TRACTOR .....	15	GRAIN CONTROL GATE .....	33
ROLLERMILL .....	16	ROLL BEARINGS .....	33
BEFORE PROCESSING .....	16	ECCENTRIC BEARING HOUSINGS .....	33
DETACHING FROM THE TRACTOR .....	16	AGITATOR SHAFT BEARINGS.....	34
<b>OPERATION OF CATTLEMAXX .....</b>	<b>17</b>	ROLLERMILL BELT DRIVE.....	34
TRACTOR PTO ENGAGEMENT.....	17	HOPPER MAGNETS .....	34
PROCESSING .....	17	CHAINS.....	34
ROLLERMILL .....	17	GEARBOX .....	35
DRIVELINE PROTECTION .....	18	LOWER VERTICAL MIXING AUGER.....	35
HOPPER MAGNETS.....	18	UPPER VERTICAL MIXING AUGER .....	35
GRAIN CONTROL GATE.....	18	TANK VENT .....	35
ROLL GAP .....	18	UNLOADING AUGER CLUTCH.....	35
ROLLERMILL ROLLS.....	19	SWIVEL CLAMP.....	36
ROLL SELECTION .....	20	ELBOW .....	36
ROLL SPEED DIFFERENTIAL.....	20	RING AND WORM GEAR (MECHANICAL) .....	36
ROLL SCRAPERS.....	20	WHEELS .....	36
PROCESSING WITHOUT MIXING .....	20	<b>SERVICE.....</b>	<b>37</b>
ADDING CONCENTRATE OR SUPPLEMENT.....	20	TORQUE SPECIFICATIONS.....	37
FILLING THE MIXER TANK .....	21	SHEAR BOLTS .....	37
SPRING LOADED TANK LID .....	22	SPROCKET AND CHAIN ALIGNMENT .....	37
UNLOADING AUGER POSITIONING .....	23	REPLACEMENT ROLLS.....	38
Manual Crank.....	23	ROLL REPLACEMENT.....	38
Tractor Hydraulic Lift And Swing .....	23	<b>TROUBLESHOOTING GUIDE.....</b>	<b>39</b>
		<b>ATTACHMENTS .....</b>	<b>41</b>
		ELECTRONIC SCALE ATTACHMENT .....	41
		DISCHARGE UNLOADING AUGER EXTENSIONS .....	41
		<b>SPECIFICATIONS .....</b>	<b>42</b>

## LIMITED WARRANTY

Art's-Way Manufacturing Co., Inc. warrants the products it sells to be free from defects in material and workmanship for a period of one (1) year after the date of delivery to the first (original) purchaser, subject to the following conditions:

- Art's-Way Manufacturing Co., Inc. obligation and liability under this warranty is to repair or replace (at the company's option) any parts that upon manufacture were defective in material or workmanship.
- All parts and repairs under this warranty shall be supplied at Art's-Way Manufacturing Co., Inc. or an authorized Art's-Way Manufacturing Co., Inc. dealer, at the option of Art's-Way Manufacturing Co., Inc.
- Art's-Way Manufacturing Co., Inc. warranty does not extend to parts and elements not manufactured by Art's-Way Manufacturing Co., Inc. and which carry the warranty of other manufacturers.
- Transportation or shipping to an authorized dealer for necessary repairs is at the expense of the purchaser.
- Art's-Way Manufacturing Co., Inc. makes no other warranty expressed or implied and makes no warranty of merchantability or fitness for any particular purpose beyond that expressly stated in this warranty. Art's-Way Manufacturing Co., Inc. liability is limited to the terms set forth in this warranty and does not include any liability for direct, indirect, incidental or consequential damages or expenses of delay and the Company's liability is limited to repair or replacement of defective parts as set forth herein.
- Any improper use and/or maintenance, including operation after discovery of defective or worn parts, operation beyond the rated capacity, substitution of parts not approved by Art's-Way Manufacturing Co., Inc., or any alternation or repair by other than an authorized Art's-Way Manufacturing Co., Inc. dealer which affects the product materially and adversely, shall void the warranty.
- No dealer, employee or representative is authorized to change this warranty in any way or grant any other warranty unless such change is made in writing and signed by an officer of Art's-Way Manufacturing Co., Inc.
- Some states do not allow limitations on how long an implied warranty lasts or exclusions of, or limitations on relief such as incidental or consequential damages, so the above limitations or exclusions may not apply to you. This warranty gives you the specific legal rights and you may have other rights that vary from state to state.

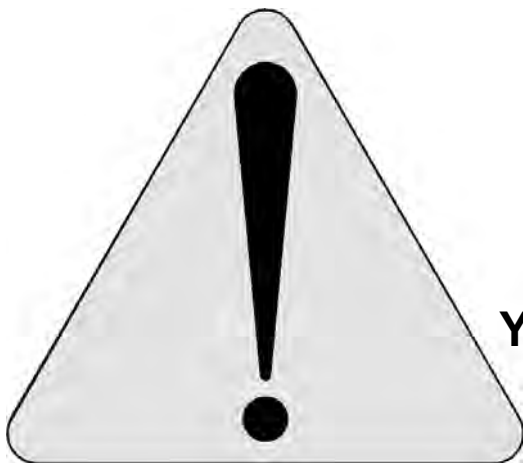
## SAFETY FIRST

***“A careful operator is the best insurance against an accident”***

(National Safety Council)

Most accidents can be prevented if the operator:

- Fully understands how the machine functions
- Can anticipate situations which may produce problems
- Can make necessary corrections before problems develop



**THIS SYMBOL MEANS  
ATTENTION!  
BECOME ALERT!  
YOUR SAFETY IS INVOLVED!**

**Figure 3 - Universal Safety Alert Symbol.**

The American Society of Agricultural Engineers has adopted the Universal Safety Alert Symbol as a way to identify areas of potential danger if the equipment is not operated correctly. (See Figure 3.) Please be alert whenever you see this symbol in the manuals or on your CattleMaxx.

Art's-Way Manufacturing Co., Inc. strives to make our equipment as safe as possible. The Art's-Way CattleMaxx conforms to applicable safety standards at the time of manufacturing. A safety conscious equipment operator makes an effective accident-prevention program complete.

Safety features and instructions for the CattleMaxx are detailed in the section of this Operator's Manual. It is the responsibility of the owner to ensure that all operators read and understand the manual before they are allowed to operate the CattleMaxx. (Occupational Safety and Health Administration (OSHA) regulations 1928.57.)

### **NOTICES OF DANGER, WARNING, AND CAUTION**

Signal Words: Note the use of signal words **DANGER**, **WARNING**, and **CAUTION** on the CattleMaxx and in this manual. The appropriate signal word for each has been selected using the following guidelines:



**DANGER: IMMEDIATE AND SPECIFIC HAZARD WHICH *WILL* RESULT IN SEVERE PERSONAL INJURY OR DEATH IF PROPER PRECAUTIONS ARE NOT TAKEN.**



**WARNING: SPECIFIC HAZARD OR UNSAFE PRACTICE *COULD* RESULT IN SEVERE PERSONAL INJURY OR DEATH IF PROPER PRECAUTIONS ARE NOT TAKEN.**



**CAUTION: A REMINDER OF GOOD SAFETY PRACTICES. PERSONAL INJURY *COULD* RESULT IF PROPER PROCEDURES ARE NOT FOLLOWED.**



## SAFETY GUIDELINES



### **Remember:**

***“The Best Operator is a Safe Operator”***



**CAUTION: READ AND UNDERSTAND THE OPERATOR’S MANUAL AND ALL THE SAFETY DECALS BEFORE OPERATING THE CATTLEMAXX. REVIEW ALL SAFETY INSTRUCTIONS WITH ALL OPERATORS ANNUALLY.**

### **BEFORE OPERATING**

- Do not wear loose fitting clothing as it may catch in moving parts.
- Make sure to install and/or secure all guards, doors and shields, including the tractor power take-off (PTO) master shield, before starting or operating the CattleMaxx.
- Be sure that the correct implement driveline parts are used and that they are properly secured.
- Install the safety chain when attaching the CattleMaxx to the tractor.
- Clear the area of bystanders, especially children, when making repairs, adjustments or performing maintenance on the CattleMaxx.
- Do not allow riders.
- Put all tractor and machine controls in “neutral” and disengage the PTO before starting. Follow the starting instructions according to your tractor Manual.
- Operate the CattleMaxx only while seated on the tractor seat.
- Make sure the unit is adequately supported with safety blocks or safety stands when changing tires or performing maintenance.



**CAUTION: KEEP WELL CLEAR OF MOVING PARTS. BE SURE TO SHUT OFF THE TRACTOR AND SET THE PARKING BRAKE. REMOVE THE TRACTOR KEY WHILE MAKING ANY ADJUSTMENTS. WAIT FOR ALL MOVEMENT TO STOP BEFORE APPROACHING THE MACHINE.**

### **DURING OPERATION**

- Keep hands, feet, hair, and clothing away from moving parts.
- Keep all guards, doors and shields in place and in good working condition.
- Keep all bystanders, especially children, away from the CattleMaxx while in operation.
- Do not allow riders while the CattleMaxx is in operation.
- Do not attempt to unclog, clean, or adjust the CattleMaxx while it is running.
- Stay away from overhead power lines. Electrocutation can occur even without direct contact.
- Keep all hydraulic lines, fittings, and couplers tight and free of leaks. (Refer to - Hydraulic Safety.)
- Use caution when ascending or descending on the CattleMaxx. Wet shoes or boots are slippery.

### **MAINTENANCE SAFETY**

- Follow all operating, maintenance and safety instructions found in this Manual.
- Before servicing, adjusting, repairing or unclogging the machine, always make sure the tractor engine is stopped, the parking brake is set, and all the moving parts have stopped.
- Use sufficient tools, jacks, and hoists that have the capacity for the job.
- Use support blocks or safety stands when changing tires or performing maintenance.
- Follow good shop practices of keeping the service area clean and dry and use adequate light for the job at hand.
- Before applying pressure to the hydraulic system, make sure all lines, fittings and couplers are tightly secured and in good condition.
- Make sure all guards, doors and shields are in place and properly secured when performing maintenance.



## **HYDRAULIC SAFETY**

- Make sure components in the hydraulic system are kept clean and in good working condition.
- Relieve pressure from the hydraulic system before servicing or disconnecting from the tractor.
- Keep all hydraulic lines, fittings, and couplers tightly secured and free of leaks.
- Replace any worn, cut, abraded, flattened or crimped hoses.
- Do not make any temporary repairs to the hydraulic lines, fittings or hoses using tape, clamps, or cement. The hydraulic system operates under extremely high pressure and temporary repairs may fail suddenly and create a hazardous and or dangerous situation.
- Wear proper hand and eye protection when searching for a high-pressure hydraulic leak. Use a piece of wood or cardboard as a backstop instead of hands to identify and isolate a leak. If injured by a concentrated high-pressure stream of hydraulic fluid, seek medical attention immediately. Serious infection or toxic reaction can develop if hydraulic fluid penetrates the surface of the skin.
- Before applying pressure to the system, make sure all components are tight and that the hydraulic lines, hoses, and couplings are not damaged.

## **TRANSPORTATION SAFETY**

- Make sure the CattleMaxx complies with all local regulations regarding the transportation of equipment on public roads and highways.
- Make sure the Slow Moving Vehicle (SMV) emblem and all lights and reflectors required by local highway and transportation authorities are properly in place, clean, and clearly visible to traffic.
- Do not allow riders on any machinery during transport.
- Make sure the CattleMaxx is securely attached to the tractor and install a safety chain to the CattleMaxx.
- Make sure the tractor brake pedals are latched together.
- Do not exceed 20 mph (32 km/h) when transporting the CattleMaxx. Always reduce speed on rough roads and surfaces, or when going down inclines.

- Use caution when turning and always use the turn signals on the tractor to indicate your turning intentions to the other traffic.
- The weight of the trailed machine should NEVER exceed the weight of the towing vehicle.
- Check all clearances carefully whenever the machine is towed.
- Lower the elevator into the transport position before transporting the CattleMaxx on the highway.
- Stay away from overhead obstructions and power lines during transport. Electrocution can occur even without direct contact.

## **STORAGE SAFETY**

- Store the CattleMaxx in an area away from human activity.
- Do not permit children to play on or around the stored machine at any time.
- Make sure that the CattleMaxx is stored in an area with a firm and level base to prevent the machine from tipping or sinking into the ground.
- Block the wheels to prevent the machine from rolling.

## **TIRE SAFETY**

- Have only a qualified tire dealer or tire repair service perform tire repairs.
- Do not attempt to install a tire on a wheel or rim unless you have the proper equipment and experience to do the job.
- Follow proper procedures when installing a tire on a wheel or rim to prevent an explosion that could result in serious injury.
- Do not substitute tires with a lesser road rating and/or capacity for the original equipment tires.



**CAUTION: FAILURE TO FOLLOW PROPER PROCEDURES WHEN INSTALLING A TIRE ON A WHEEL OR RIM CAN PRODUCE AN EXPLOSION THAT MAY RESULT IN SERIOUS INJURY OR DEATH. DO NOT ATTEMPT TO INSTALL A TIRE UNLESS YOU HAVE THE PROPER EQUIPMENT AND EXPERIENCE TO PERFORM THE JOB. REPLACEMENT, REPAIR, AND/OR MAINTENANCE SHOULD BE DONE BY A QUALIFIED TIRE DEALER OR QUALIFIED REPAIR SERVICE.**

**ASSEMBLY SAFETY**

- Use adequate manpower to perform assembly procedures safely.
- Assemble the CattleMaxx in an area with sufficient space to maneuver the largest components and allow easy access to all sides of the machine.
- Use only forklifts, lift cranes, jacks and tools with sufficient capacity for the loads.
- Do not allow spectators, especially children, in the working area.

***Remember:***

***“The Best Operator is a Safe Operator”***

## SAFETY DECALS

### DECAL LOCATIONS & IDENTIFICATION

The different types of safety decals for your CattleMaxx are illustrated on the following pages (See Figure 4 and Figure 5). Please familiarize yourself with the appearance of each decal, the warning it describes, and the area where it is located on the CattleMaxx.

Safety awareness is the responsibility of each operator of the CattleMaxx. Keep safety decals and signs clean and legible and be sure replacement parts display the current safety decals and signs as well.

**Remember: Always replace missing, damaged or illegible safety decals. New decals and signs are available from an authorized dealer.**

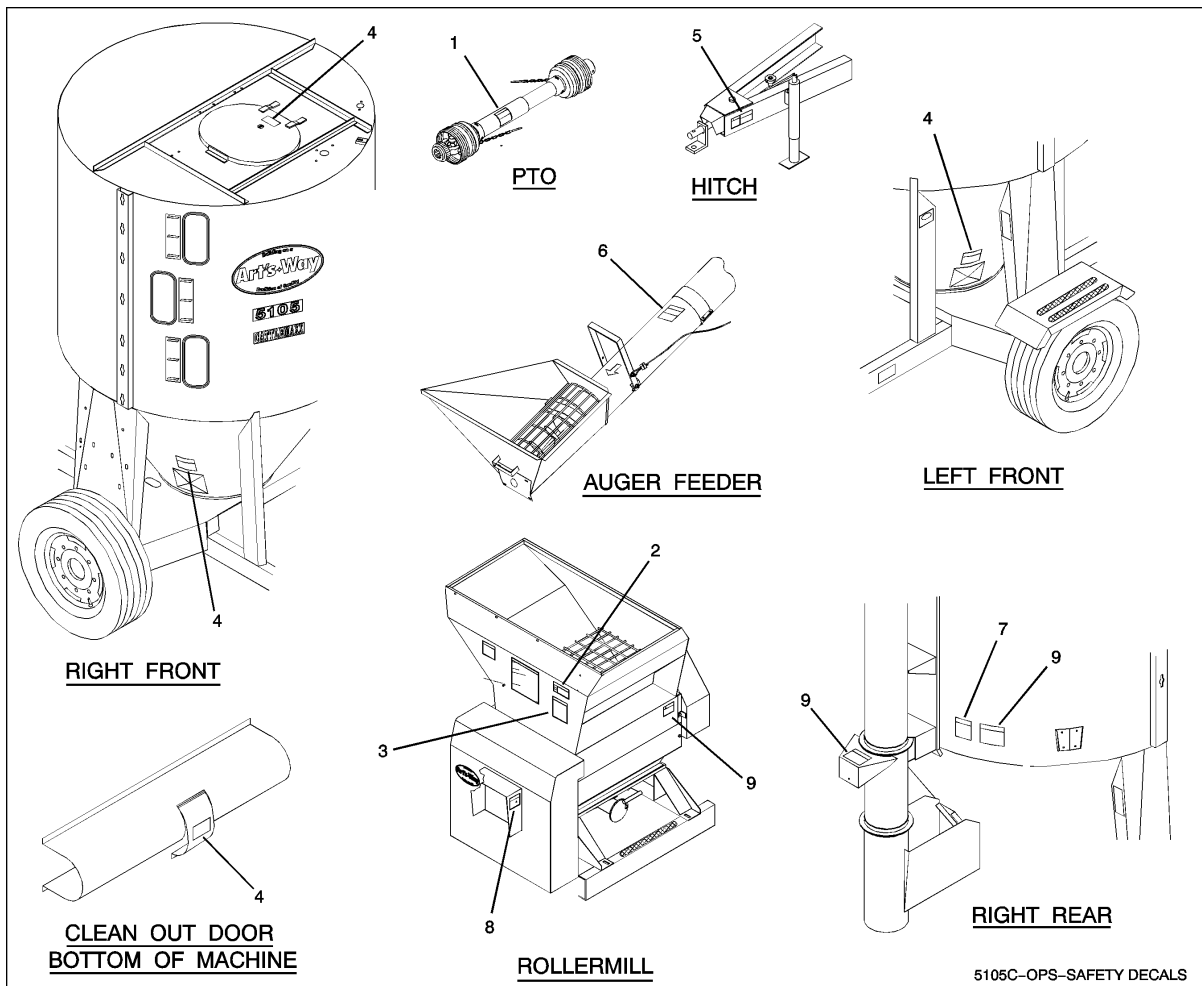


Figure 4 - CattleMaxx Decals

FIG ITEM	PART NUMBER	NOMENCLATURE	UNITS PER ASSY
1	268860	DECAL, DANGER ROTATING DRIVE LINE	1
2	P99897	DECAL, WARNING ROLLS, BELT	1
3	368040	DECAL, CAUTION SAFETY INSTRUCTIONS	1
4	377280	DECAL, CAUTION DO NOT OPEN	4
5	383970	DECAL, CAUTION HITCH INSTRUCTIONS	1
6	383990	DECAL, DANGER AUGER FEEDER	1
7	384000	DECAL, DANGER ELECTROCUTION HAZARD	1
8	384030	DECAL, DANGER 565 RPM PTO	1
9	467450	DECAL, WARNING MOVING PART HAZARD	3

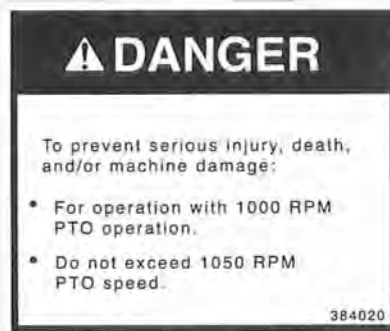
**NOTE:** Keep all decals clean and free of dirt for maximum visibility. Replace all individual decals that are no longer legible. Read and obey all safety decals and be familiar with their meaning.



1. DANGER - Rotation Mechanism (363000)



2. DANGER - 540 RPM PTO (384030)



3. DANGER - 1000 RPM PTO (384020)



4. DANGER - Rotating Driveline (268860)



5. DANGER - Auger Feeder Hazard (383990)

Figure 5 - Safety Decals.

**NOTE:** Keep all decals clean and free of dirt for maximum visibility. Replace all individual decals that are no longer legible. Read and obey all safety decals and be familiar with their meaning.



6. DANGER - Electrocution Hazard (384000)



7. WARNING - Moving Flywheel Hazard (368350)



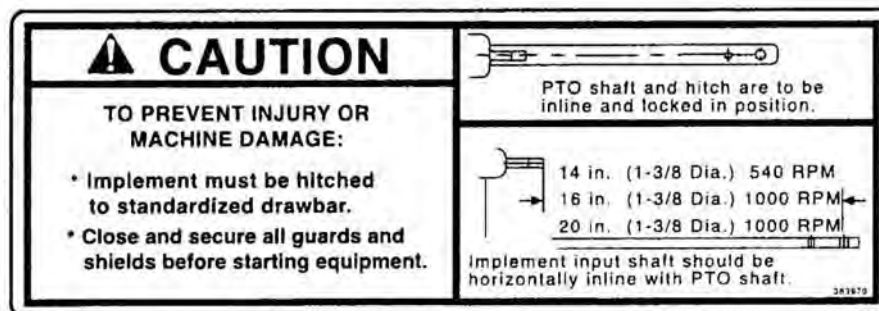
8. WARNING - Moving Part Hazard (384020)



9. CAUTION - Safety Instructions (368040)



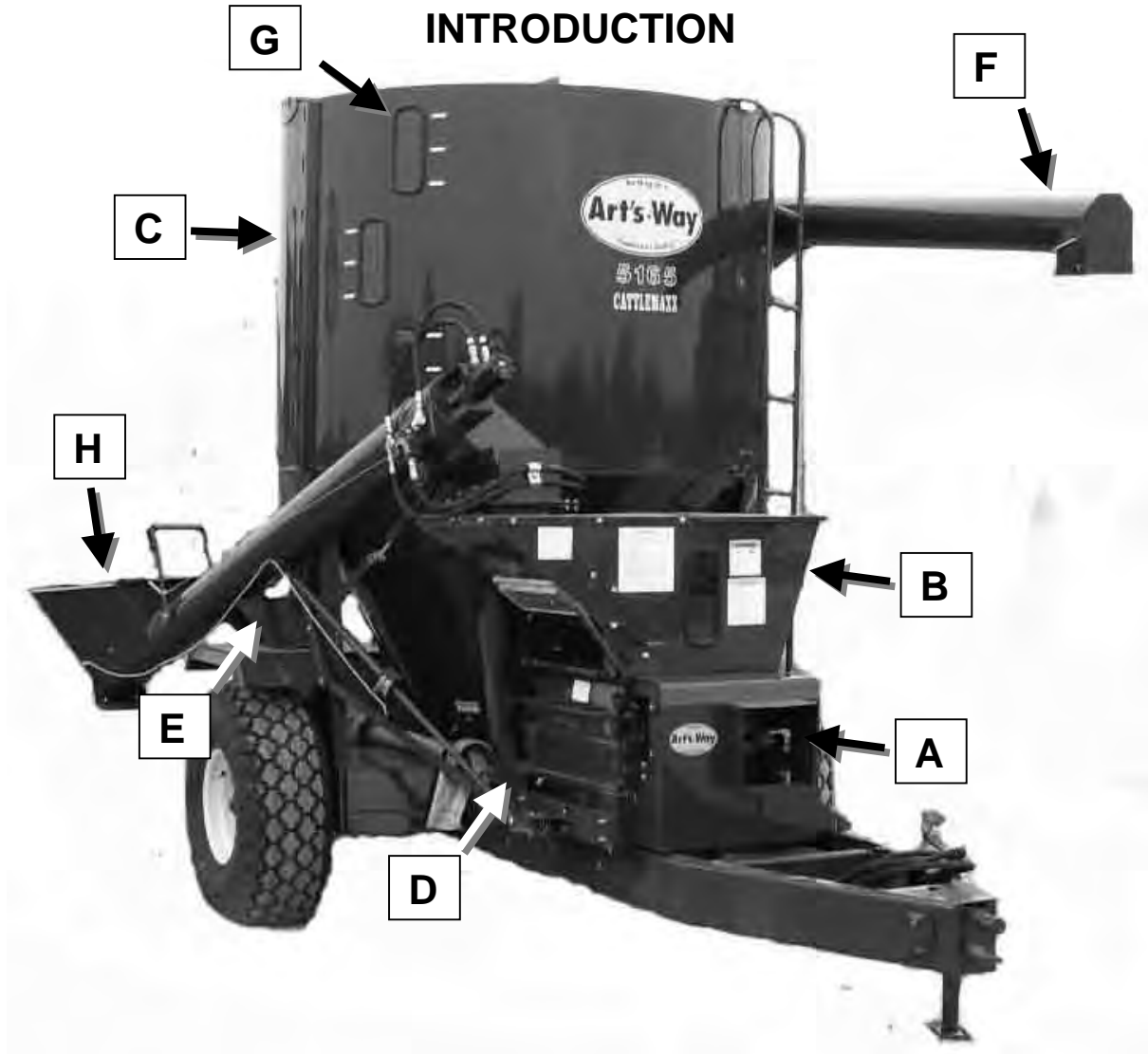
10. CAUTION - Do Not Open (377280)



11. CAUTION - Hitch Instructions (383970)

Figure 6 - Safety Decals.

**NOTE:** Keep all decals clean and free of dirt for maximum visibility. Replace all individual decals that are no longer legible. Read and obey all safety decals and be familiar with their meaning.



**Figure 7 - CattleMaxx With Auger Feeder (A – PTO Driveline; B – Rollermill; C – Mixing Tank; D – Dust Collector; E – Supplement Hopper; F – Unloading Auger; G – Viewing Windows; H – Auger Feeder).**

This manual has been prepared to make you familiar with the proper operation, adjustment, lubrication and service of your CattleMaxx. Take time to be careful and better understand the efficient operation and care of your machine.

Whenever the terms “Left” and “Right” are used, it should be understood to mean standing behind the machine and facing the direction of forward travel.

***Some pictorials are used to show guards, doors and shields removed for easy identification. Make sure that all guards, doors and shields are in place before operating the machine. They are for your protection.***

The Art’s-Way CattleMaxx is driven by a PTO driveline of 40 hp to 130 hp tractors and is factory available with a 540 RPM drive.

Always operate at full speed while rolling grain.



**CAUTION: NEVER OPERATE A 540 RPM PROCESSOR WITH A 1000 RPM TRACTOR.**

The rollermill (Figure 7, Detail B) is precision built of tough, cast iron construction, designed to give a high degree of control over the quality of feed produced.

It is important that you become acquainted with your rollermill before operating at full capacity. The rollermill will not start with grain between the rolls.

If supplement is to be added to the ration, a hopper (Figure 7, Detail E) with a sack cutter is located at the right rear of the mixing tank. The best mixing will result if the supplement is added before grinding.

The rolled feed is mixed continuously until the tractor PTO is disengaged.

The unloading auger (Figure 7, Detail F) pivots at the rear center of the mixing tank and can swing 324 degrees on the 5105 CattleMaxx or 316 degrees on the 5165 CattleMaxx in a horizontal arc and in a vertical arc to the limit of the lift assist spring. The unloading auger tube can be positioned either to the right or to the left side of the tank for transport. Unloading rates up to 30 bushels per minute can be obtained depending upon position of the discharge and the type of material processed.

Three viewing windows (Figure 7, Detail G) are located at the front right corner of the mixing tank to observe the feed level during grinding and mixing.

A ladder is located at the front left corner of the mixing tank to gain access to the spring-loaded mixing tank lid.



**CAUTION: DO NOT OPEN SPRING-LOADED MIXING TANK LID WHILE PTO IS ENGAGED AND TRACTOR IS RUNNING.**

Many convenient features are standard equipment on the Art's Way CattleMaxx including:

1. Heavy Duty 540 RPM implement driveline with shear clutch.
2. 20 inch heavy duty rollermill. 30 inch heavy duty rollermill (5165 Only)
3. Roll scrapers
4. Rollermill hopper magnet system.
5. Feed inspection tube under rollermill.
6. Ingredient supplement hopper.
7. Tongue jack and safety chain.
8. Ladder and fenders.
9. Three large inspection windows in tank.
10. Spring loaded tank lid.
11. Discharge lift assist and brake.
12. 8 inch diameter by 10 foot long unloading auger.
13. Discharge auger hood with spring loaded relief baffle.

CattleMaxx 5105 (105 bu.)

1. 10.00 x 15 tires.
2. 29 inch vertical discharge.

CattleMaxx 5165 (165 bu.)

1. 13.50 x 16.1 tires.
2. 52 Inch vertical discharge
3. Hydraulic discharge

Below is a list of optional attachments available:

1. Hydraulic auger feeder.
2. Electronic scale, with digital readout. Microprocessor model is also available.
3. Horn, light, or horn and light for electronic scale.
4. Unloading auger extensions; 3 ft. or 6 ft. folding or bolt-ons.
5. Highway transport light kit.
6. Mechanical or hydraulic discharge (5105 CattleMaxx)
7. Roll speed differential drive rollermill.

## PREPARING THE CATTLEMAYX FOR OPERATION

Remove the shipping banding or wire from the auger feeder (if equipped), rear discharge cover and the unloading tube to saddle at the side of the tank.

Remove the bag from the supplement hopper. A wrench is provided for adjusting the roll gap spacing of the roller mill. Keep this wrench with the mill at all times. If equipped with mechanical lift and swing, the crank for the unloading auger is in the bag. Place it in the hanger near the crank position for lift and swing. Install the PTO driveline storage bracket under front hitch with 1/2 inch X 1-1/2 inch bolt and lock nut. (See Figure 8). Maintain tension with lock nut to allow movement with 15 lbs. pull.



**Figure 8 - PTO Driveline Storage Bracket.**

Install any option that was ordered with the machine and shipped as loose equipment. See package instructions with the specific options for installation.

Install the implement end of the PTO driveline by fastening it to the input jackshaft with the 5/16 inch X 3-1/2 inch clevis pin and cotter pin provided. Spread the cotter pin and make sure the proper PTO is used.



**CAUTION: NEVER OPERATE A 540 RPM CATTLEMAYX WITH A 1000 RPM TRACTOR.**

**NOTE:** Height of the unloading auger tube needs to be checked. Move the saddle on the side of the mixing tank so the tube will properly clear the tractor and cab. This is especially important with bolt-on auger extension.

If equipped with a tractor hydraulic auger feeder or roll feed, refer to page 17 and page 18 for additional instructions

### TIRES

Keep tires properly inflated. Lack of pressure can result in torn valve stems, fabric breaks and uneven tread wear. Too much pressure can cause undue strain on fabric, excessive tread wear and allows the tire to cut in more on wet surfaces.

Equal tire pressure reduces CattleMaxx sway when towing.

Recommended tire inflation pressure is as follows:

10.00 x 15	8 – PR tires – 40 psi	5105 CattleMaxx
13.5 x 16.1	8 – PR tires – 28 psi	5165 CattleMaxx

### SHIELDS

Make sure that all shields are in place and functioning.

### BOLTS AND NUTS

Before starting to operate the CattleMaxx check all nuts and bolts for tightness. Also check that all cotter pins are spread. After operating the CattleMaxx for several hours, check all the bolts for proper torque. Refer to the torque guide. (See Table 1.)

Size	Clamp Load	Plain GR 5	Plated GR 5
1/4 – 20 (.250)	2,025	8 ft. lbs.	76 in. lbs.
5/16 – 18 (.3125)	3,338	17 ft. lbs.	13 ft. lbs.
3/8 – 16 (.375)	4,950	31 ft. lbs.	23 ft. lbs.
7/16 – 14 (.4375)	6,788	50 ft. lbs.	37 ft. lbs.
1/2 – 13 (.500)	9,075	76 ft. lbs.	57 ft. lbs.
9/16 – 12 (.5625)	11,625	109 ft. lbs.	82 ft. lbs.
5/8 – 11 (.625)	14,400	150 ft. lbs.	112 ft. lbs.
3/4 – 10 (.750)	21,300	266 ft. lbs.	200 ft. lbs.
7/8 – 9 (.875)	29,475	430 ft. lbs.	322 ft. lbs.
1 – 8 (1.00)	38,625	644 ft. lbs.	483 ft. lbs.
1-1/8 – 7 (1.125)	42,375	794 ft. lbs.	596 ft. lbs.

**Table 1 - Torque Specification Guide For Grade 5 Bolts.**

Cap screws, except for shear bolts, used on the grinder mixer are Grade 5 and if replaced, cap screws of equal or greater strength should be used. Grade 5 cap screws are identified by three radial dashes on the hex head. Refer to the SAE bolt identification guide. (See Figure 9.)



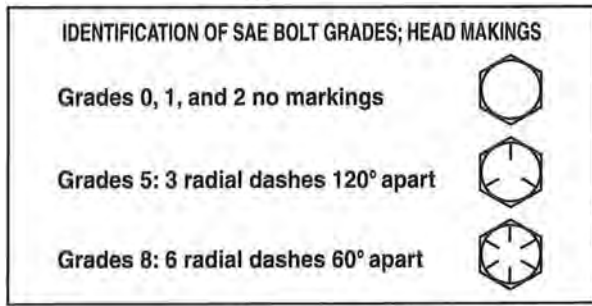


Figure 9 - SAE Bolt Identification.

**IMPORTANT:** Shear bolts must be replaced with bolts of the same grade. See “Service” section on page 37.

Lubricate the CattleMaxx at regular intervals as instructed in the lubrication sections. (Refer to the LUBRICATION section page 33.)

**PREPARING THE TRACTOR**

The tractor must be equipped with a 540 RPM PTO to match the CattleMaxx as described in the previous section. Make sure the CattleMaxx and the tractor are equipped and set for the proper RPM.

**CAUTION: NEVER OPERATE A 540 RPM CATTLEMAXX WITH A 1000 RPM TRACTOR PTO.**

**TRACTOR HITCH**

The hitch for the CattleMaxx is designed to attach to any SAE – ASAE standardized tractor drawbar. Adjust the drawbar so it is 13 to 17 inches above the ground (See Figure 10). Extend or shorten the tractor drawbar so the horizontal distance from the end of the tractor PTO shaft to the center of the hitch pin hole is 14 inches for 540 RPM drives.

Lock the drawbar in its crossbar, parallel with the centerline of the PTO. Place locking pins on each side of the drawbar. If the tractor has an offset drawbar, the offset should be down for PTO work.

**IMPORTANT:** An improperly located hitch point may cause damage to the universal joints (U-Joints) of the PTO driveline.

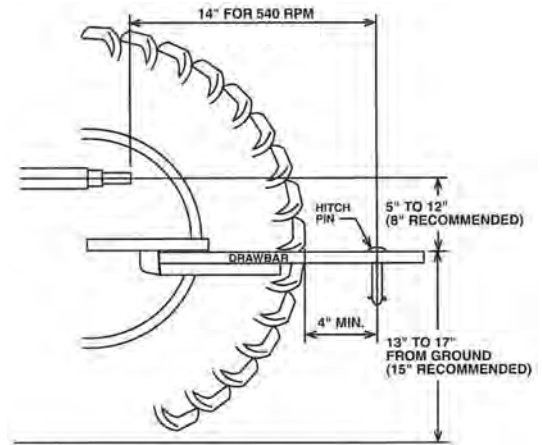


Figure 10 - Hitch Point Locations

**ATTACHING TO THE TRACTOR**

**NOTE:** Height of the unloading auger tube needs to be checked. Move the saddle on the side of the mixing tank so the tube will properly clear the tractor and cab.

Carefully back the tractor up to the hitch. Use the crank of the jack to raise or lower the CattleMaxx hitch into position to engage the tractor drawbar.

Fasten the CattleMaxx hitch to the drawbar with a hitch pin that can not bounce out. Raise the jack and lock into the transport position (See Figure 11). Attach the safety chain from the grinder mixer to the tractor (See Figure 12).

**CAUTION: ALWAYS FOLLOW STATE AND LOCAL REGULATIONS REGARDING A SAFETY CHAIN WHEN TOWING FARM EQUIPMENT ON PUBLIC HIGHWAYS.**



Figure 11 - Jack In Transport Position



Figure 12 - CattleMaxx Attached To The Tractor With Safety Chain.

If the CattleMaxx is equipped with an electronic scale, plug the scale power supply cord into the electrical outlet on the tractor or to the battery on the CattleMaxx frame.

**IMPORTANT:** On electronic scale applications, if a bolt and nut are used in place of a hitch pin, the nut must not be tightened to where it hits against the underside of the weigh bar clevis.

If the CattleMaxx is equipped with a tractor hydraulic function, install the proper male ends on the hoses and plug the hydraulic line hoses into the tractor outlets. Refer to page 32 for open and closed center instructions.

Connect the PTO driveline to the tractor PTO shaft. The PTO operating speed of the tractor and CattleMaxx must be the same. The tractor half of the PTO is equipped with 6 splines for 540 RPM operation.



**CAUTION: NEVER OPERATE A 540 RPM GRINDER MIXER WITH A 1000 RPM TRACTOR.**

After connecting PTO driveline to tractor, anchor driveline implement shield chain in main shield base slot and the tractor shield chain to the tractor drawbar.

### ROLLERMILL

Check that the rollermill feed control gate is closed and remove any debris on top of the gate. The rollermill will not start if there is any material or debris in the rolls (See Figure 13)

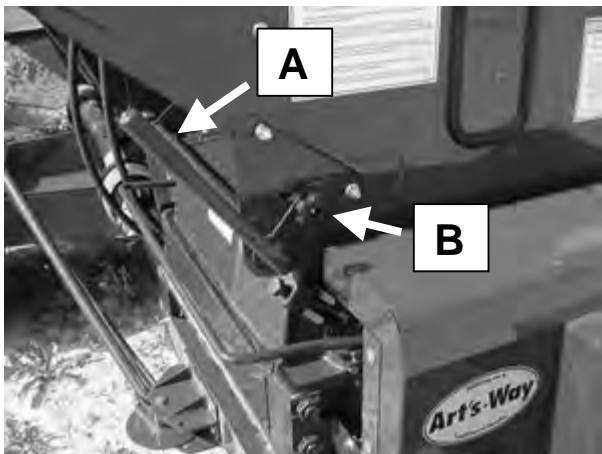


Figure 13 - Rollermill In Closed Position (A - Gate Lever; B - Gate locking Knob).

### BEFORE PROCESSING

New machines should be operated before preparing feed. A few hundred pounds of coarse material such as shelled corn or ground cobs should be ran through the grinder mixer. This will remove the protective oil coating from the mixer cone and any metal particles that may be in the machine. This will help polish the cone and prevent bridging. After several minutes of running the grinder mixer, unload the mixture and discard. **Do not feed this mixture to the livestock.**

### DETACHING FROM THE TRACTOR



**CAUTION: MAKE SURE THE TRACTOR IS SHUT OFF, REMOVE THE KEY AND PLACE THE KEY IN YOUR POCKET.**

Disconnect the PTO driveline and front shield anchor chain from the tractor and place it on the PTO driveline support bracket (See Figure 14). The PTO driveline support should be tight enough to remain in position when rotated from storage against the frame to use position.

Disconnect the electronic scale power cord from the tractor (if equipped).

Disconnect the hydraulic hoses from the tractor outlets (if equipped with tractor hydraulic functions).

Make sure the discharge auger and the auger feeder are in their saddles before disconnecting.

Block the tires. Lower the jack stand to the ground. Turn the handle of the jack stand to raise the CattleMaxx tongue off of the tractor hitch. Remove the hitch pin and safety chain.



Figure 14 - PTO Support.

## OPERATION OF CATTLEMAXX



**CAUTION: KEEP WELL CLEAR OF MOVING PARTS. BEFORE RUNNING THE CATTLEMAXX, KEEP ALL CHILDREN AND BYSTANDERS AWAY FROM THE MACHINE.**

### TRACTOR PTO ENGAGEMENT

The CattleMaxx may be operated by engaging the PTO. Always engage the tractor PTO with the tractor engine at idle speed. After the PTO is engaged, increase the engine speed gradually until the desired operating speed is obtained. Reverse the PTO engagement steps to disengage the PTO.

Before processing, position the tractor straight with the frame of CattleMaxx. This will allow smoother PTO operation and prolong PTO driveline life.

**IMPORTANT:** If mixing while in transport, avoid sharp and unnecessary turns that may damage the PTO driveline.

The CattleMaxx does not have a main drive clutch, so the rollermill, supplement hopper auger and mixing tank auger will run whenever the tractor PTO is engaged. The unloading auger will only operate when the unloading auger clutch is engaged.

### PROCESSING

A rollermill processor is designed to process grains without the fines and deviations in particle size experienced with hammermills. However, a rollermill is limited in capacity compared to a hammermill in that the rate of feed processing is restricted by the roll gap and roll selection, and more horsepower will not increase capacity of the mill. It is important that you become familiar with the rollermill before operating it at full capacity.

All projected particle sizes will vary depending on the quality and moisture content of the grain, roll gap, power input, roll speed differential drive, and the general operation of the mill.

Always operate the rollermill at full speed (540 RPM) when processing. Slower speeds will increase power requirements and may cause damage or excessive wear to mill components.

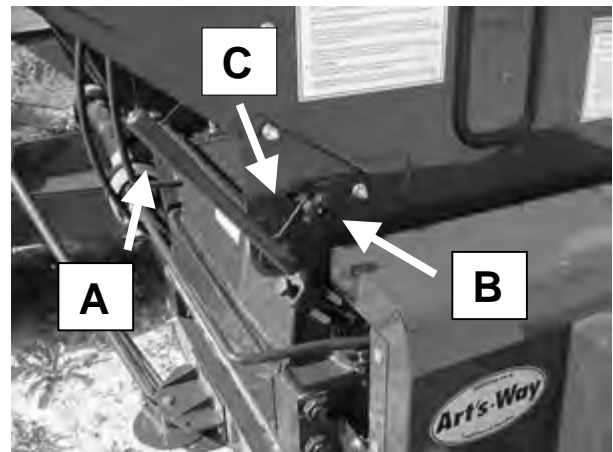
### ROLLERMILL

The rollermill drive is a direct drive without a drive clutch, so the rolls will turn at all times. The drive consists of a direct driven drive roll, which drives the eccentric (Adjustable) roll and hopper agitator shaft through a rear belt drive. Always start and stop the CattleMaxx at low speeds so as not to damage any drive components.

To operate the rollermill, engage the tractor PTO at a low RPM and increase speed to the full rated 540 RPM. Start to fill the hopper with grain, allowing the full width of the hopper to fill to just above the magnet before operating the grain control gate. Open the grain control gate to the desired opening and lock the knob (See Figure 15). When processing is complete, allow the hopper to empty completely and close the grain control gate fully, locking the knob to keep the gate closed. Stop the rollermill and disengage the PTO at a low RPM only after the grain control gate has been closed and all grain in the rollermill has been processed.

**IMPORTANT:** Never stop the rollermill with grain in the rolls. The rollermill will not start if any grain is wedged in the apex of the rolls.

The rollermill will not start if there is any material between the rolls. If material does get into the rolls without the PTO engaged, the roll gap must be opened or the material cleaned from the rolls before the rolls can be turned.



**Figure 15 - Grain Control Gate Operation (A - Gate Lever; B - Gate Locking Knob; C - Lever Gauge).**

### DRIVELINE PROTECTION

The CattleMaxx driveline is protected from overloading by a shear clutch located at the end of the PTO driveline on the drive roll (See Figure 16). Always replace the shear clutch bolt with a metric M10-1.5 x 60 bolt. Use of any other type or size of shear bolt will compromise the driveline protection of the machine.



Figure 16 - PTO Driveline Shear Clutch

### HOPPER MAGNETS

Two plate magnets are located in the hopper above the rollermill (See Figure 17). Always load the hopper from the right-hand side to utilize these magnets. A magnet assembly is also located in the hopper throat just above the rollermill rolls. This is standard equipment on all machines to help protect the mill from tramp metal. It is important to keep the magnets clean and monitor their condition.

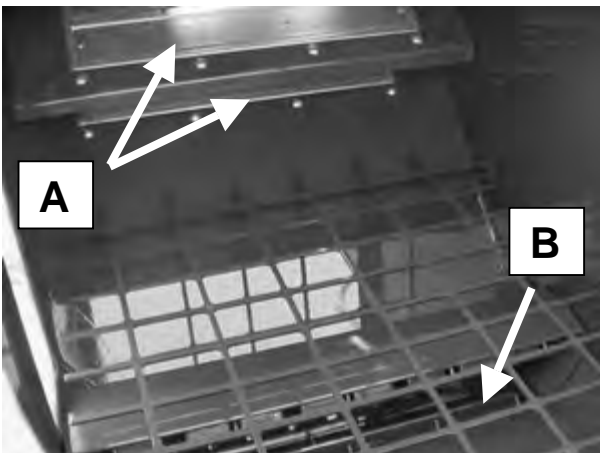


Figure 17 - Plate Magnet In Hopper (A - Plate Magnets; B - Throat Magnet).

### GRAIN CONTROL GATE

The grain control gate is used to regulate the flow of grain into the rollermill. The grain control gate lever is located at the front right corner of the mill (See Figure 18). To adjust the grain control gate, loosen the knob and push or pull the lever to close or open the gate. Each slot on the grain control gate lever gage is approximately 0.25 inch of gate opening. Tighten the knob to hold the gate in place once the desired opening is set.

Open the grain control gate after the rollermill has been started and the hopper as about half full (grain showing in the hopper inspection window). Open the control gate enough to allow a smooth grain flow into the rollermill. Recommended control gate opening is 0.5 inch to 1.0 inch. A high grain flow rate will cause grain to boil on top of the rolls and decrease capacity of the rollermill.

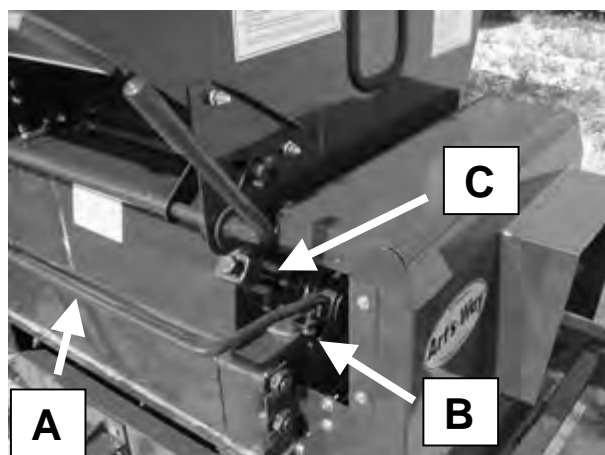
**IMPORTANT:** The grain control gate should be opened only enough to provide the rate of processing required, with a maximum gate opening of 1.0 inch.

Opening the grain control gate more than 1.0 inch will overload the mill and cause mill vibrations, and also result in lower capacity, larger grain particle size, undo drive stress, shortened roll life, and excessive power requirements. When the CattleMaxx is operated for the first time, the feed rate from the auger feeder or bin should be restricted until you become acquainted with the capacity of the unit.

Always ensure that the grain control gate is closed during transport or when not in use. This will prevent material from falling into the apex of the rolls and preventing the rollermill from starting.

### ROLL GAP

Roll gap is the space between the rollermills rolls, which is used to control the particle size of the rolled feed. A roll gap of 0.010 inch is set at the factory and should never be set less than 0.008 inch. This setting is determined by the adjustment of the eccentric roll handle stops (See Figure 18). Use this minimum setting for fine processing and open the roll gap for coarser processing. Use the pointer on the front bearing housing of the eccentric roll for wider roll gap setting reference.



**Figure 18 - Eccentric Roll Settings (A - Eccentric Handle; B - Eccentric Handle Stops; C - Eccentric Roll Lock Bolt).**

The minimum roll gap on the roller mill must be maintained to ensure a consistent particle size. This should be monitored as the rolls wear and will also need to be adjusted for any replacement or regrooved rolls.

Roll gap should be set for each type of grain. It is not recommended to process mixed grains as greater particle size deviation will occur. You are encouraged to experiment with the roll gap setting to meet the requirements of rolling different grains in your operation. Particle size can be monitored by using the grain inspection trough under the left-hand side of the roller mill to take feed samples (See Figure 19).



**Figure 19 - Grain Inspection Trough.**

Be careful not to over roll grains with too small of a roll gap setting on the roller mill. Over rolling takes more power, reduces capacity, and causes unnecessary roll wear. The roller mill should be ordered with the rolls grooved for the smallest grains to be rolled.

Be careful when adjusting the roll gap to always pull on the eccentric roll handle evenly, either from both ends or from the center. Do not pull up on the eccentric roll handle from only one end, as twisting or bending the handle will move one of the eccentric roll more than the other and cause the rolls to become out of parallel with each other. Parallel rolls must be maintained to achieve uniformity in the feed particle size.



**CAUTION: NEVER ADJUST THE ROLL GAP WHILE THE CATTLEMAXX IS RUNNING.**

The roller mill is equipped with a positive pressure eccentric roll release to automatically open the gap between the rolls. This is to minimize damage to the rolls and drive train from the induction of tramp metal or other foreign objects into the rolls. Opening the grain control gate too far and overloading the rolls can also cause the eccentric roll release to trip. Indications that the eccentric roll release has been tripped are a sudden higher particle size in the processed feed and the eccentric roll handle has moved up. The eccentric roll release must be reset if this occurs.

The eccentric roll release is set by tightening the eccentric lock bolts after the eccentric roll handle has been positioned for desired roll gap (See Figure 18). The lock bolts tighten down on a brass plug, which pushes against a knurled surface on the eccentric roll bearing housing. Excessive pressure between the roll will shear the brass plug and open the roll gap.

Do not over-tighten the eccentric lock bolts, as this will render the eccentric roll release ineffective. Tighten the eccentric lock bolts only until they are snug. Use only the wrench provided to tighten the eccentric lock bolts so as not to over torque the bolts.

### **ROLLERMILL ROLLS**

The roller mill rolls in the CattleMaxx are made of heat treated cast iron. The rate of wear on the roll is dependent upon the hardness or abrasiveness of the grain, the amount of overloading done, and damage resulting from foreign objects such as tramp metal, stones, etc. Increase in particle size and horsepower requirements are signs of increased roll wear. rolls should be replaced when they become worn down and the surface is slick and shiny.

Worn rolls can be regrooved and re-heat treated by Art's-Way. Refer to the "Service" section of this manual for information on replacement rolls.

## ROLL SELECTION

Roller mill rolls can be purchased with either a sharp or flat groove cut. The sharp groove rolls offer a higher capacity and finer particle size while the flat groove rolls are for flaking or cracking grains.

Roller mill rolls can be cut with 5, 7, or 10 grooves per inch. The 10 groove roll will take any small grain and is recommended for wheat, milo, barley, oats, etc. The 7 groove roll will also take these small grains as well as shell corn, however the smaller kernels may pass through the rolls uncracked. It is suggested to use a combination of one 7 and one 10 groove roll when using multiple grains such as corn and milo. The 5 groove roll is recommended for use with shell corn. The coarser groove rolls will have a higher capacity than the fine groove rolls (See Table 2).

When using roll combinations with different grooves (sharp to sharp or flat to flat) the coarser grooved roll is the drive roll. When combining sharp and flat rolls with the same number of grooves, the drive roll is the sharp roll.

Capacity of the roller mill is dependent upon the roll selection as well as the roll gap, roll speed differential, condition of the roller mill, and quality of material.

Rolls	Material	Aprox. Bu./Hr.
10 Groove	Oats	200 to 300
	Wheat/Barley	200 to 300
	Milo/Corn	300 to 400
7 Groove	Milo/Corn (Dry)	350 to 450
	Milo/Corn (Hi Moisture)	300 to 400
5 Groove	Milo/Corn (Dry)	400 to 600
	Milo/Corn (Hi Moisture)	350 to 550

Table 2 - Roll Capacity Chart

## ROLL SPEED DIFFERENTIAL

Your CattleMaxx roller mill may be equipped with a belt driven roll speed differential. This increases the speed of the eccentric roll, which causes a scrubbing effect on the rolls helping to keep them clean. The CattleMaxx rolls should be equipped with a roll speed differential if high moisture grain is to be used. A roll speed differential has also been found to decrease particle size and increase capacity of the roller mill.

## ROLL SCRAPERS

The CattleMaxx roller mill is equipped with roll scrapers to help prevent material from packing onto the rolls. With coarse or dry material, the spiral design of the roll groove cut keeps the rolls clean and roll scraper setting is not as critical. For fine or high moisture material, a higher tolerance roll scraper setting should be maintained. Allowing material to build up on the rolls will cause a loss of capacity and excess load on the drive components.

Roll scraper setting needs to be monitored as the rolls wear and should be adjusted after changes in a minimum roll gap setting or when replacing rolls. The main drive roll scraper should be set at 0.006 inch clearance and the eccentric roll scraper should be set at 0.050 inch clearance.

## PROCESSING WITHOUT MIXING

To process any material without mixing, engage the unloading auger lever, open the tank unloading auger door and start the processing operation.

The feed will be augered into the mixing tank cone and then out through the unloading augers without mixing. Position the unloading auger tube as needed to direct the feed.

## ADDING CONCENTRATE OR SUPPLEMENT

Concentrate or supplement should be added to the ground feed through the supplement hopper located at the right rear corner of the CattleMaxx (See Figure 20). A serrated sack cutter is located in the hopper opening. A grate is positioned below the sack cutter to keep the bag from falling into the auger.

***For best results, add the concentrate or supplement before grinding operation. Do not add ingredients to the supplement hopper while grinding, this will over load the auger.***



Figure 20 - Supplement Hopper On Right-Hand Side Of Machine.



**CAUTION: KEEP HANDS AND FEET CLEAR OF AUGER. MAKE SURE GRATE IS ALWAYS IN PLACE.**

Addition of very fine ingredients or commodities that do not need to be processed should be added to the mixer either through the supplement hopper or through the rollermill with an increased roll gap. Fine ingredients or commodities will tend to pack onto the rolls set with a narrow roll gap and may cause the eccentric roll release to trip if the roll gap is less than the roll scraper clearance.

If micro-ingredients are to be added to the feed, the best results are obtained with a pre-mix, or by adding the supplements and micro-ingredients at the same time. If the micro-ingredients are desired without a pre-mix or other supplement, open the mixing tank lid and add the ingredients directly into the mixer. This should be done at the beginning of the operation. Make sure to close the lid before starting the operation. The supplement hopper lid should always be closed when not in use.

If strong additives are not desired in the batch that follows, clean out the tank cone and unloading augers through the clean-out doors (See Figure 21).



**CAUTION: MAKE SURE THE PTO IS DISENGAGED AND THE TRACTOR IS SHUT OFF. PLACE THE KEY IN YOUR POCKET BEFORE OPENING OR CLOSING THE CLEAN-OUT DOOR.**



**Figure 21 - Tank Cone Clean-Out Door On Right-Hand Side.**

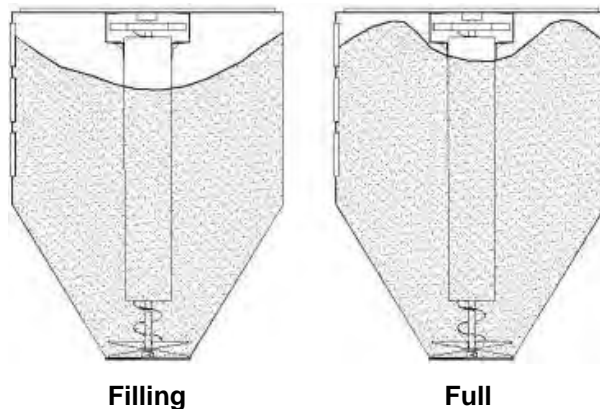


**Figure 22 - Clean-Out Door Located Under Right-Hand Side Of Tank Assembly.**

Located under the right-hand side of the frame and tank assembly is a hinged door on the bottom of the auger trough. Release two spring clamps and allow door to drop. Keep away from the opening. Run the mixer slowly until the trough and the mixing tank are cleaned out. Keep all bystanders away from the machine.

### **FILLING THE MIXER TANK**

Make sure the mixing tank unloading door is closed. As the mixing tank is filling, watch the ground feed through the mixing tank windows. If the top window is covered, this does not mean the tank is full as the mixing auger throws material away from the center of the tank. Continue loading until the top window clears (feed drops) and then becomes covered again about half-way (See Figure 23.). Stop feeding material into the processor at this point, but continue operating until the processor has had time to clear. ***Do not overload the mixer.*** An overload can cause damage to the machine. To estimate the number of bushels that are in the tank, refer to Table 3.



**Figure 23 - Filling pattern**

For the best mixing results, always add lightweight bulky materials first. Always add high moisture corn or grain last. Excessive amounts of wet or bulky material may cause *bridging* in the mixing tank.

**105 BU. – APPROXIMATE CAPACITY CALIBRATION – IN POUNDS\***

Actual weights may vary due to material, moisture, and screen size. Ration weight is not included and is variable.

Window Position	Ground Oats 22.5 lbs/bu	Ground Barley 36 lbs/bu	Ground Milo 56 lbs/bu	Ground Shelled Corn 50 lbs/bu	Ground Ear Corn 38 lbs/bu	Un-ground Shelled Corn 56 lbs/bu
Full	2346	3754	5839	5213	3962	5839
9	2219	3549	5521	4930	3747	5521
8	2046	3274	5092	4547	3456	5092
7	1874	2998	4664	4164	3165	4664
6	1659	2654	4129	3687	2802	4129
5	1487	2379	3701	3304	2511	3701
4	1315	2103	3272	2921	2220	3272
3	1100	1760	2737	2444	1857	2737
2	928	1484	2038	2061	1566	2038
1	756	1208	1880	1678	1276	1880

**NOTE:** \* Above weights are approximate and are to be used as a guide only. Variations may occur due to test weight of grain, slope of machine, moisture content, or screen size. For best ration control use an electronic scale.

**Table 3 – Tank Capacity for 5105 (105 bu) and 5165 (165 bu).**

**165 BU. – APPROXIMATE CAPACITY CALIBRATION – IN POUNDS\***

Actual weights may vary due to material, moisture, and screen size. Ration weight is not included and is variable.

Window Position	Ground Oats 22.5 lbs/bu	Ground Barley 36 lbs/bu	Ground Milo 56 lbs/bu	Ground Shelled Corn 50 lbs/bu	Ground Ear Corn 38 lbs/bu	Un-ground Shelled Corn 56 lbs/bu
Full	3777	6043	9400	8393	6378	9400
9	3554	5686	8845	7897	6002	8845
8	3302	5282	8217	7337	5576	8217
7	3047	4876	7585	6772	5147	7585
6	2768	4429	6890	6152	4676	6890
5	2528	4044	6291	5617	4269	6291
4	2287	3659	5692	5082	3862	5692
3	1985	3176	4941	4412	3353	4942
2	1744	2791	4342	3877	2947	4342
1	1504	2406	3743	3342	2540	3743

**NOTE:** \* Above weights are approximate and are to be used as a guide only. Variations may occur due to test weight of grain, slope of machine, moisture content, or screen size. For best ration control use an electronic scale.

**Table 4 - Approximate Calibration Capacity.**

**SPRING LOADED TANK LID**

**CAUTION: DISENGAGE ALL THE DRIVES. SHUT OFF THE TRACTOR ENGINE AND PLACE THE KEY IN YOUR POCKET BEFORE OPENING THE MIXING TANK LID.**



**CAUTION: IF ENTERING THE TANK, MAKE SURE THE TRACTOR ENGINE IS SHUT OFF. PLACE THE KEY IN YOUR POCKET AND DISCONNECT THE PTO DRIVELINE.**

If the mixing tank is accidentally overfilled, it is equipped with a spring loaded tank lid (See Figure 24). The lid also allows access to the inside of the mixing tank. Keep the lid closed and latched at all times.



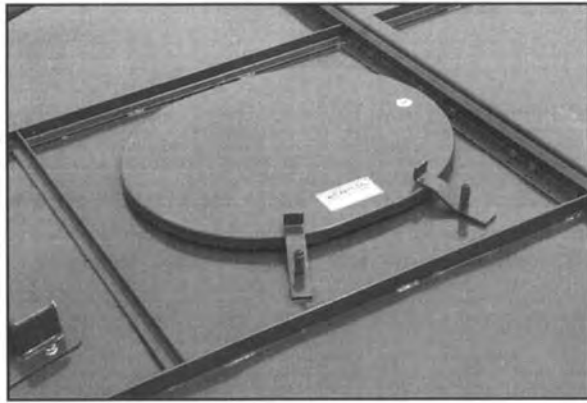


Figure 24 - Spring Loaded Tank Lid.

After the processing is completed and the desired ration is in the mixing tank, allow the mixer to operate until it is ready to unload. Run the mixer 2 to 3 minutes to ensure the feed and supplements have been thoroughly mixed.

**IMPORTANT:** Avoid sharp and unnecessary turns that may damage the PTO driveline during transport.

**UNLOADING AUGER POSITIONING**

After mixing, the finished feed may be unloaded into storage bins, wagons, or feeders. Positioning (Lift and Swing) of the unloading auger and drive for the unloading auger may be controlled in two ways: Manual Crank or Tractor Hydraulic Lift And Swing.

**Manual Crank**

Insert crank on the shaft next to channel to lift and on the shaft at the rear of lower auger housing to swing the unloading auger (See Figure 25 and Figure 26). A brake is provided to prevent movement after positioned (See Figure 27.)

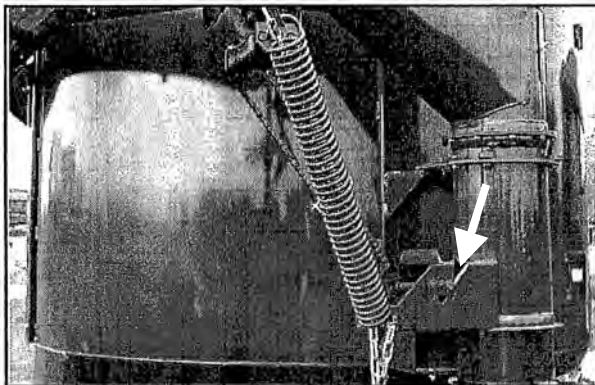


Figure 25 - Manual Lift

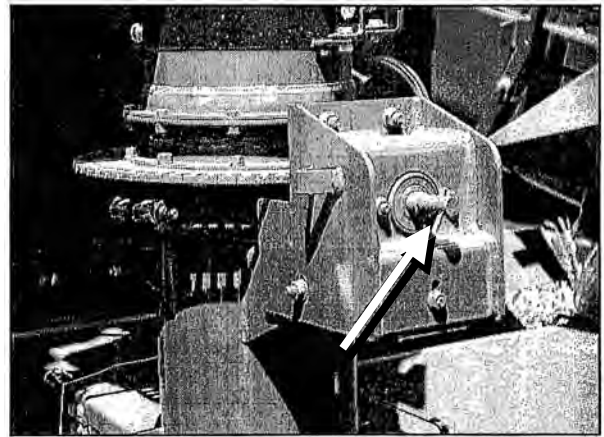


Figure 26 - Manual Swing

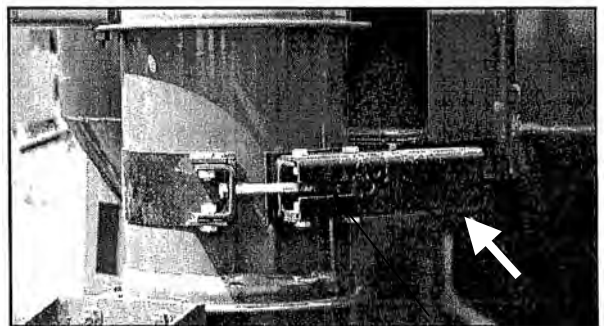


Figure 27 - Manual Brake

**Tractor Hydraulic Lift And Swing**

Hydraulic lift and swing is accomplished by using the hydraulic system valves. If a hydraulic auger feeder is present, a double selector valve is required to direct flow of the hydraulic fluid. Either the swing motor or the auger feeder may be operated independently but not at the same time. (See Figure 28.) Position the selector valve control "IN" to direct fluid to discharge the swing function. Make sure spool goes fully against the snap ring when moving lever in.

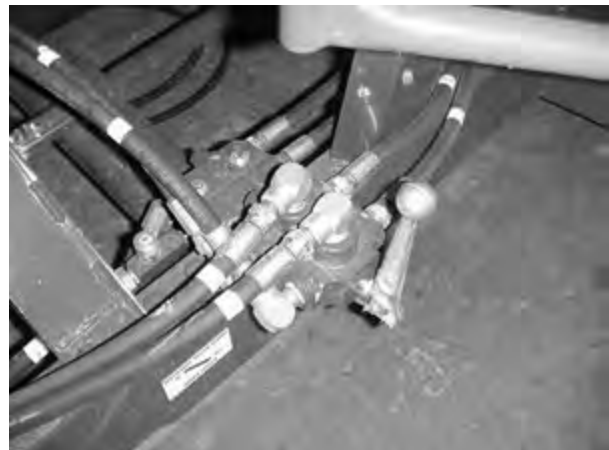


Figure 28 - Hydraulic Selector Valve (Lever In The In Position - Hydraulic Swing).

Connect four hydraulic hoses with the appropriate male connectors to the tractor. Make sure the proper hoses are connected to the same tractor hydraulic circuit. Activate the appropriate tractor valve to lift the unloading auger, then use the other hydraulic valve to swing the unloading auger to the desired position.

### **UNLOADING AUGER ENGAGEMENT**

Operate the tractor at a minimum of 2/3 throttle for unloading. This allows the discharge augers to move the feed through the discharge elbows more efficiently with lower driveline stress.

### **UNLOADING CLUTCH DRIVE**

Starting at an idle, move the clutch handle ahead and down to engage the augers. (See Figure 29.) Gradually increase speed to at least 2/3 throttle. Open the unloading door. The eccentric may be used to hold the door open. (See Figure 30.) When the tank is unloaded, reverse the procedure.

If unloading in more than one location, close the discharge door and empty the auger before transporting the CattleMaxx. Transporting or adjusting the discharge auger height with material in the discharge auger will cause excessive wear to the ring and worm gear assembly and discharge auger system.

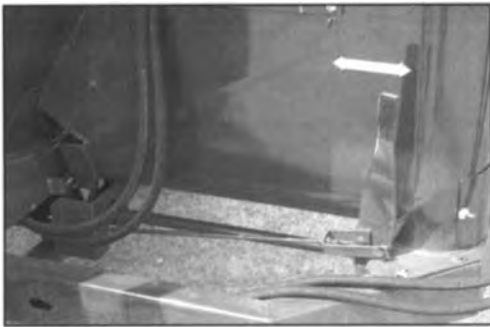


Figure 29 - Unloading Clutch Operation.

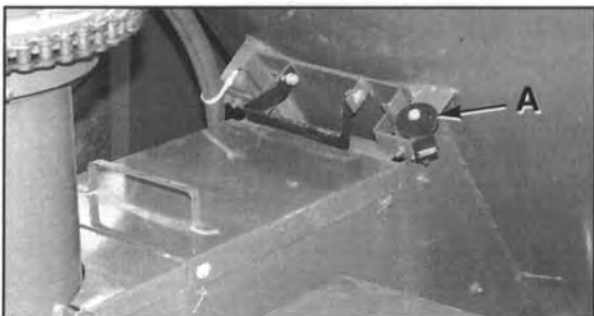


Figure 30 - Unloading Door (A - Eccentric Lock).

### **FOLDING AUGER EXTENSION**

Optional extensions for the unloading auger include a 3 to 6 feet folding or bolt-on extension. (See Figure 31.) For discharge heights of the optional extensions (See Figure 32).

If the CattleMaxx is equipped with a folding auger extension, make sure the outer auger drive cog is properly engaged and the extension tube is locked before engaging the unloading clutch.

Always make certain that a bolt on auger extension will clear the tractor cab during transport. Folding augers extensions should be in the folded position for transport.

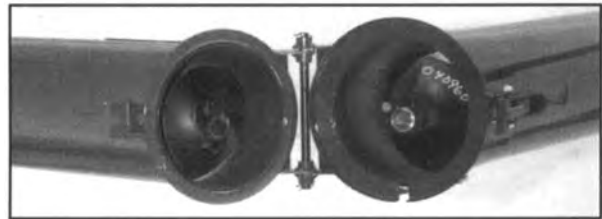


Figure 31 - Folding Auger Extension.

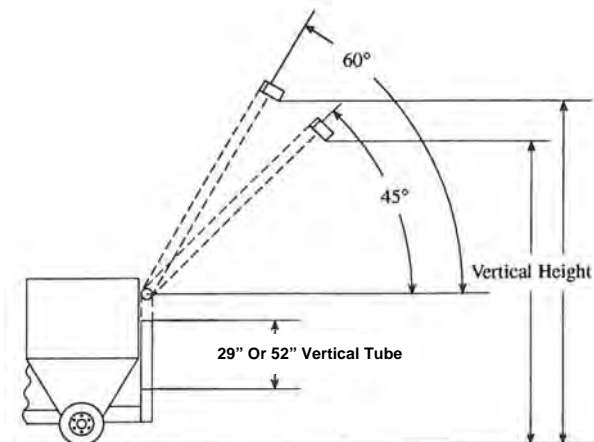


Figure 32 - Unloading Auger Heights (Refer To Table 5 For Detailed Heights.)

### **UNLOADING AUGER HOOD**

When the unloading auger tube becomes overloaded, a spring loaded door opens on the end to prevent damage to the drive. (See Figure 33.)

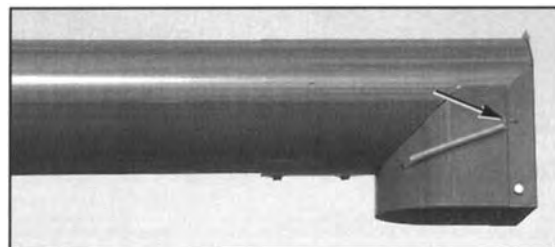


Figure 33 - Unloading Auger Hood.

Unloading Auger Configuration	Tube & Elbow Combined Length	Discharge 45°		Discharge 60°	
		29" Tube	52" Tube	29" Tube	52" Tube
<b>105 Bu.</b>					
Standard - No Extensions	125 in.	14 ft 19 in	N/A	16 ft 8 in.	N/A
3 ft. Fold Around Auger Extension	161 in.	17 ft 0 in.	N/A	19 ft 3 in.	N/A
6 ft. Fold Around Auger Extension	197 in.	19 ft 8 in.	N/A	22 ft 0 in.	N/A
<b>165 Bu.</b>					
Standard - No Extensions	125 in.	N/A	16 ft 4 in.	N/A	18 ft 3 in.
3 ft. Fold Around Auger Extension	161 in.	N/A	18 ft 7 in.	N/A	20 ft 10 in.
6 ft. Fold Around Auger Extension	197 in.	N/A	20 ft 10 in.	N/A	23 ft 7 in.

**Table 5 - Unloading Auger Heights**

**AUGER FEED OPERATION**

**NOTE:** The CattleMaxx may be equipped with a hydraulic auger feeder.

To position the auger feeder, remove the clip pin from the fender bracket and lift the bottom of the auger feeder slightly so the brackets can clear the fender. Swing the auger feeder outward, away from the tank to ensure it will clear the fender when it is lowered. Lift the auger feeder slightly and pull the rope on the right hand side to disengage the height adjustment ratchet bar. Raise or lower to the desired height and release the rope.



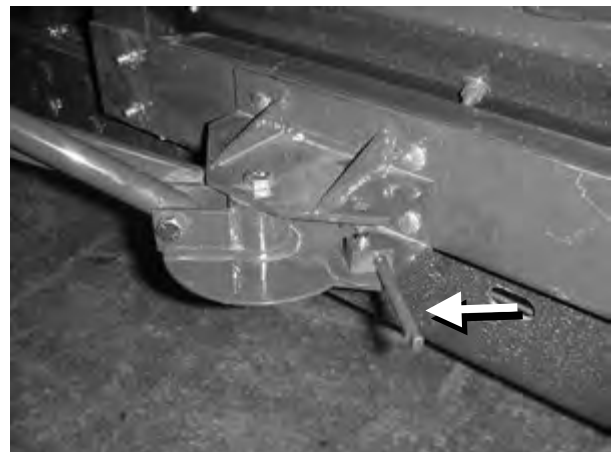
**Figure 34 – Cattlemaxx Auger Feeder**

The auger feeder swing brake prevents the auger from swinging. Tighten or loosen as desired (See Figure 35).



**DANGER: TO PREVENT PERSONAL INJURY:**

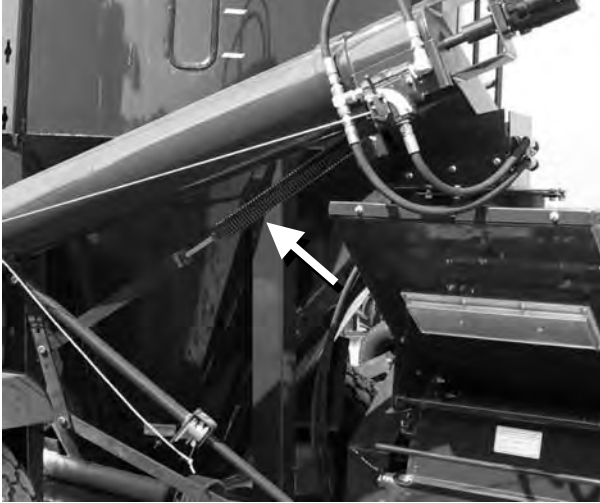
1. **USE THE GRATE OVER THE AUGER WHENEVER POSSIBLE**
2. **KEEP HANDS AND FEET OUT OF THE HOPPER AREA AND DO NOT CLIMB ON OR OVER THE HOPPER AT ANY TIME.**
3. **KEEP CHILDREN AND BYSTANDERS AWAY FROM THE MACHINE WHILE THE MACHINE IS IN OPERATION**



**Figure 35 - Auger Feeder Swing Brake**

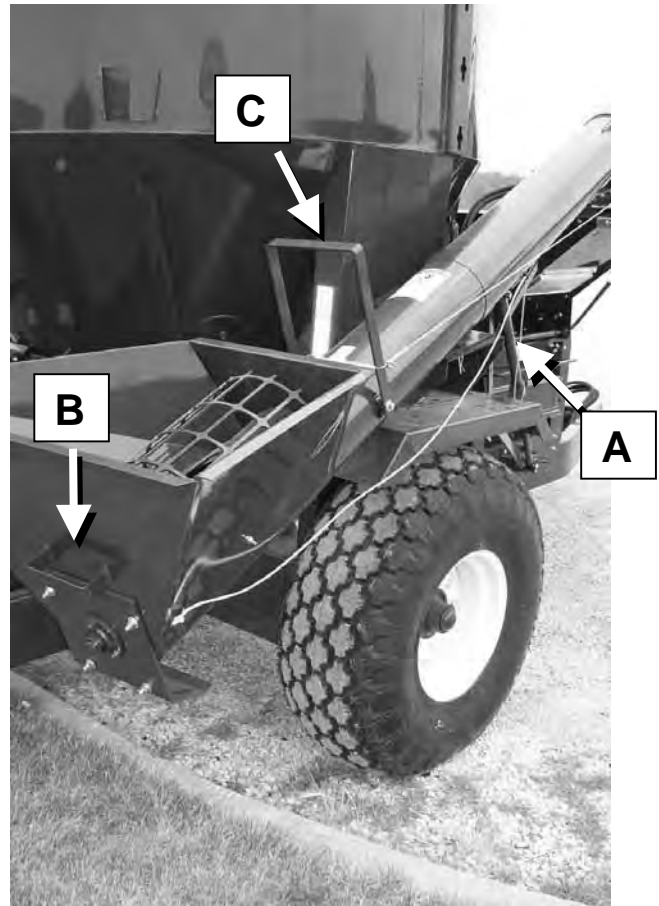
**NOTE:** If the machine is equipped with an electronic scale, to obtain a more accurate reading, **DO NOT** rest the auger feeder on the ground. Place it in the desired position and set the swing brake (See Figure 35).

The auger feeder is counter balanced by a spring (See Figure 36). Adjust the spring by loosening the nut on the lower bolt, turn the bolt in to increase the spring tension, and relock the nut.

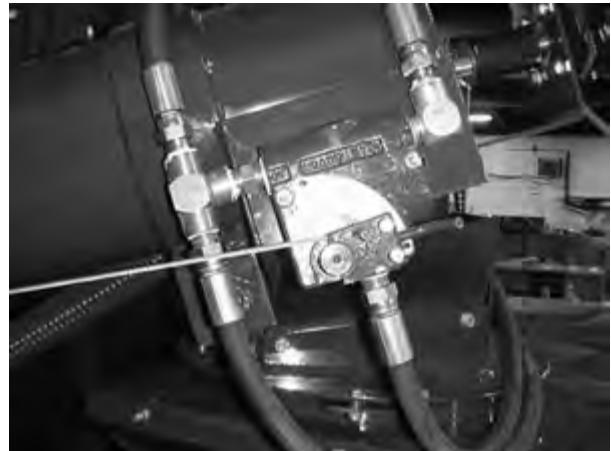


**Figure 36 – Auger Feeder Counter Balance Spring**

Shut off handles are provided at the auger feeder hopper and at the flow control valve at the top of the auger feeder housing. To shut off the auger feeder pull the handle at the hopper area or move the flow control lever to off (See Figure 37 and Figure 38). Make sure the shutoff handle at the hopper will stop the auger feeder. Loosen cable clamps to readjust.



**Figure 37 - Auger Feeder Positioner And Spring Adjustment (A - Spring; B - Positioner Handle; C - Positioner Lock).**



**Figure 38 - Auger Feeder Flow Control Valve (Shown In "ON" Position).**

For the tractor hydraulic auger feeder (when equipped with a hydraulic lift and swing unloading auger), a selector valve will be located to the left rear side of the processor. The handle on this valve must be out to divert the oil to the auger feeder.

If the handle for the selector valve is in, oil flows to the swing function of the unloading auger. (See Figure 39.)



**Figure 39 - Hydraulic Auger Feeder Selector Valve Lever Is In The *Out* Position - Auger Feeder).**

To start the auger feeder, the flow control handle is moved forward (clockwise) until the desired speed is reached.

Adjust the speed of the auger feeder to keep the rollermill hopper about half full or the grain level visible through the hopper inspection window (See Figure 40). Under filling the hopper will cause uneven roll wear and higher particle size deviation while over filling the hopper will cause the hopper plate magnets to be covered with material and making them ineffective.



**Figure 40 - Hopper Inspection Window.**

## GRINDER MIXER ADJUSTMENTS



**CAUTION: DO NOT MAKE ANY ADJUSTMENTS WHILE THE MACHINE IS IN OPERATION. BE SURE TO SHUT OFF THE TACTOR AND PLACE KEY IN POCKET WHILE MAKING ADJUSTMENTS. WAIT FOR ALL MOVEMENT TO STOP BEFORE APPROACHING MACHINE.**

### DRIVE CHAIN ADJUSTMENTS

The mill to mixer auger/supplement hopper drive chain and the discharge auger drive chain are tensioned with a wood block idler. (See Figure 41 and Figure 42.) Adjust the chain tension to 1/2 inch total deflection by positioning the wood block idler.



Figure 41 - Mill To Mixer Auger Drive Chain.



Figure 42 - Discharger Auger Drive Chain.

### MAIN DRIVE CHAIN

Adjust the tension of the main drive chain by loosening the idler roller and bolt, and then sliding the idler sprocket toward the chain. (See Figure 43.) Re-tighten the idler roller bolt and make sure the chain deflection is 1/2 inch total at the longest span.

**NOTE:** Chain should be checked and oiled daily.

### ROLL SPEED DIFFERENTIAL

Your CattleMaxx may be equipped with a belt driven roll speed differential that increases the speed of the eccentric roll. Be certain to maintain proper belt tension with stretch loaded idler (See Figure 43) as the belts will stretch during their break-in period. Improper tensioning or overloading the mill will cause the belts to slip causing premature wear and reduced belt life.



Figure 43 - Drive Chain Adjustment (Shields Removed For Clarity).

### ROLL GAP

The minimum roll gap on the mill must be maintained to ensure a consistent fine particle size. This should be monitored as the rolls wear and also need to be adjusted for any replacement or regrooved rolls.

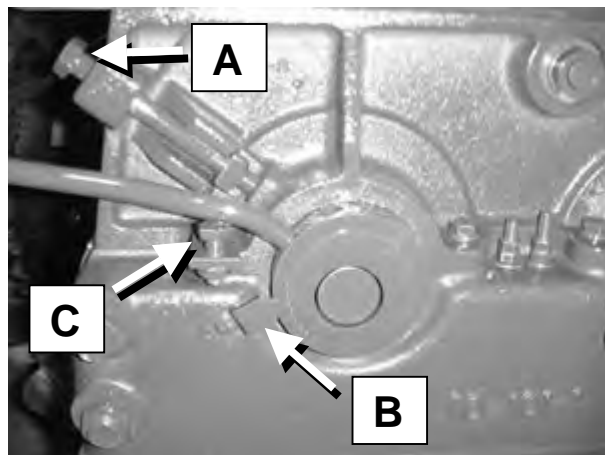


**DANGER: DO NOT MAKE ANY ADJUSTMENTS WHILE THE CATTLEMAXX IS IN OPERATION.**

To open the roll gap, loosen the eccentric lock bolts (See Figure 43 and Figure 44). with the wrench provided and pull up on the eccentric roll handle. A pointer gage (See Figure 44) on the eccentric roll bearing housing can be used as a reference for wider roll gaps. Each mark on the gage is approximately 0.015 inch of additional roll

gap. Always re-tighten the eccentric lock bolts when processing, otherwise the roll gap will open and feed particle size will increase.

To check the roll gap, remove the 20 inch magnet (See Figure 45) from the hopper throat. Using a feeler gage, check the current roll gap with the eccentric roll handle down on the stops and the eccentric lock bolts snugged down. Be sure to check the roll gap at the front and back of the rolls. Also rotate the rolls to check several different places on the roll diameter, as there may be 0.001 to 0.002 inch difference in the concentricity of the rolls.



**Figure 44 - Roller mill Housing Eccentric Bearing. A - Eccentric Lock Bolts, B - Pointer Gauge, C - Stop Bolts.**



**Figure 45 - Removing Magnet To Check Roll Spacing.**

To change the minimum roll gap, loosen the eccentric lock bolts and pull the eccentric roll handle up and out of the way. Loosen the jam nuts on the 1/2 inch stop bolts (See Figure 46) and turn both the front and rear stop bolts evenly, up for a wider roll gap and down for a smaller roll gap. Lower the eccentric roll handle to the stop bolts and re-tighten the eccentric lock bolts. Re-check the roll gap and repeat as necessary until the

desired roll gap is attained. Be sure to re-tighten the jam nuts on the stop bolts when finished.

**NOTE:** Rolls must not be set closer than 0.008 inch gap. Never adjust the minimum roll gap setting with the tractor PTO engaged. The roller mill rolls will be severely damaged if they ever touch while the PTO is engaged.

### **ROLL PARALLELISM**

If the roll gap is different from front to back on the rolls, the rolls are out of parallel and need to be adjusted. This can occur from the eccentric roll handle getting bent or twisted, or uneven roll wear from not keeping the hopper full across the whole width while processing. To adjust roll parallelism, reset one stop bolt up or down. Be certain to push down on each corner of the eccentric roll handle when tightening the eccentric lock bolts to ensure both sides of the handle are in contact with the stops. The eccentric roll handle may have to be twisted to accommodate an excessive stop bolt adjustment.

### **ROLL SCRAPERS**

Roll scraper clearance needs to be monitored as the rolls wear and should be adjusted after changes in a minimum roll gap setting or when replacing rolls. The main drive roll scraper should be set at 0.006 inch clearance and the eccentric roll should be set at 0.050 inch clearance. Be sure the minimum roll gap is set and the rolls locked in place before setting the scrapers.

To adjust the roll scrapers, loosen the jam nuts on the scraper adjustment bolts (See Figure 46). Turn the adjustment nut clockwise to bring the scraper closer to the roll. Turn the roll by hand while adjusting the scraper. When the scraper contacts the roll, back the adjusting nut off slightly until no scraper to roll contact can be heard. On the opposite side of the mill (front to back) turn the adjustment nut on the same scraper until the scraper contacts the roll. Back the adjustment nut off slightly until no scraper to roll contact can be heard. Recheck the side of the mill you started on and repeat the procedure if further adjustment is needed.



Figure 46 - Roll Scraper Adjustment Bolts

Repeat this procedure for the opposite roll. To check for actual scraper clearance, remove the side panels of the mill and measure the clearance with a feeler gage.

**NOTE:** Do not adjust rolls scrapers with the tractor PTO engaged. Roll to scraper contact with the PTO engaged will severely damage the rolls and scrapers.

#### **MANUAL UNLOADING AUGER SWING CRANK ADJUSTMENT FOR SPROCKET ENGAGEMENT**

Adjust by loosening the three bolts shown (Figure 47) and moving the assembly up to engage the teeth of the sprocket with the disk.

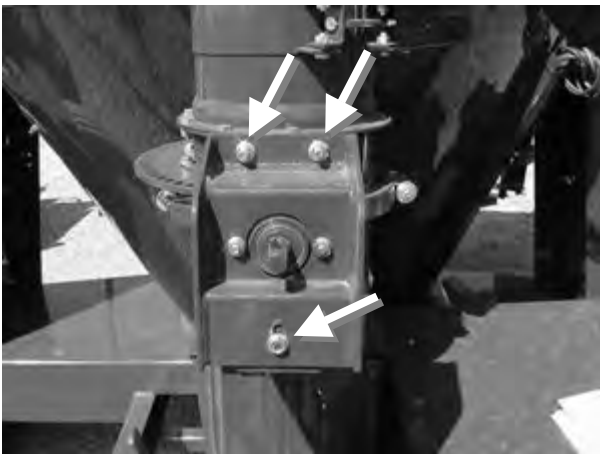


Figure 47 - Manual Unloading Auger Swing Crank Adjustment

#### **MANUAL UNLOADING AUGER SWING BRAKE ADJUSTMENT**

Tighten or loosen nut and bolt, to maintain tension to hold unloading auger (See Figure 48).



Figure 48 – Manual Brake Adjustment

#### **MANUAL LIFT ADJUSTMENT**

If the chain becomes loose, loosen bolts on the crank shaft and position chain to the proper tension (See Figure 49).

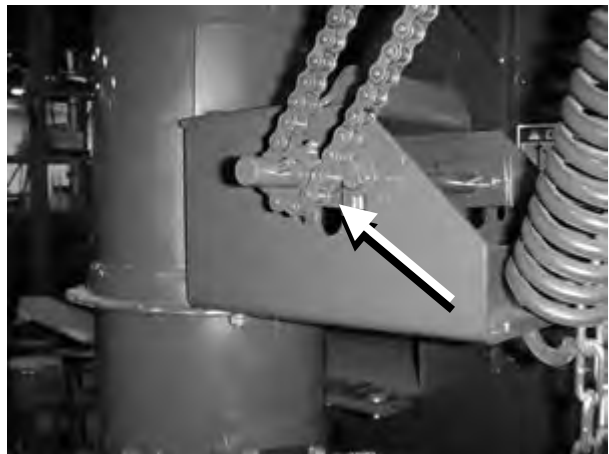


Figure 49 - Crank Shaft Chain Adjustment Bolts

#### **HYDRAULIC SWING DRIVE ADJUSTMENT**

If any problem is encountered with the hydraulic swing adjustment drive, adjust and/or check as follows: (See Figure 50.)





**Figure 50 - Hydraulic Swing Adjustment (Shields Removed For Clarity).**

1. Loosen the four hydraulic motor bolts and remove the #60 chain.
2. Wrap the #60 chain completely around the 55 tooth sprocket. Inspect the chain, matching the sprocket teeth in the two areas where the sprocket is split. If the rollers on the chain do not seat into the root of the sprocket teeth, loosen the 10 bolts that hold the sprocket to the upper ring; holding the chain across the split areas, re-tighten the bolts so the chain properly seats into the sprocket teeth.
3. Re-tighten the hydraulic motor bolts then check the alignment of the sprocket. If the sprocket is not aligned properly, loosen the set screws on the 10 tooth sprocket and re-align.
4. Reinstall #60 chain and tension. Reinstall Shield.
5. Adjust spring tension to be sure auger will slip if it hits something solid (See Figure 50). If it doesn't slip, damage to discharge could occur.

### **HYDRAULIC SWING SPEED ADJUSTMENT**

The speed of the discharge auger swing can be controlled by adjusting the flow control valves at the swing motor (See Figure 51). These valves are preset at the factory to be open 1.5 turns. When changing the swing speed be sure to adjust both valves equally. Different valve settings will cause excessive back pressure at the motor that may cause shaft seal failure.

To adjust the flow control valves, loosen the jam nut behind the knob. Turn the knob clockwise for lower flow or counter-clockwise for higher flow. Mark the knobs so they can both be adjusted equally. Tighten the jam nut after adjustments are finished and check discharge auger swing for proper operation.



**Figure 51 - Hydraulic Swing Flow Control Valves.**

### **LIFT ASSIST SPRING ADJUSTMENT**

The lift assist spring may lose tension after excessive usage. It is important to keep proper tension on the spring, this spring helps ease raising and lowering the discharge auger. Adjust the spring tension by removing bolt in hole and moving to the hole shown (Figure 52). Additional tension needed with discharge extensions.



**Figure 52 - Lift Assist Spring Adjustment Bolts**

### **POSITIONING THE UNLOADING AUGER TO OPPOSITE SIDE OF MACHINE**

To change to the opposite side, lift the unloading auger until it is straight up and comes down the opposite side. Rotate the hood downward. Move the saddle to the opposite side of the mixing tank.

An unloading auger swivel stop (See Figure 53) prevents the unloading auger from contacting the mixing tank when moved 180 degrees from the storage position. Relocate the swivel stop so it contacts the bracket before unloading auger contacts the tank.

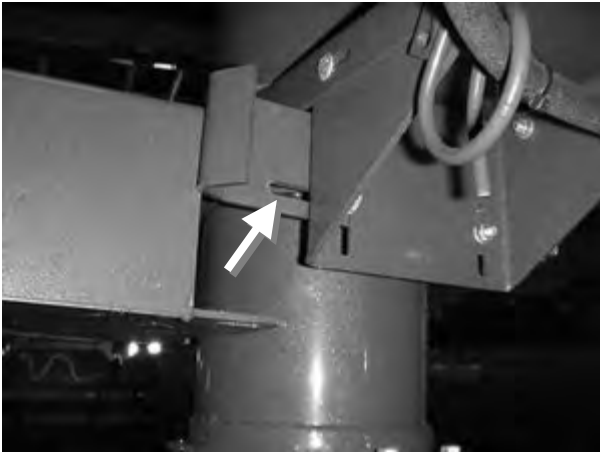


Figure 53 - Swivel Stop.

### SWIVEL STOP ADJUSTMENT

Adjust the bracket so it makes contact before the unloading auger contacts the tank when moved 180 degrees from the storage position (See Figure 53).

### OPEN AND CLOSED HYDRAULICS

As the standard, this machine is equipped for tractor “Open Center” hydraulic operation.

If the operation of the auger feeder is to be with a tractor that is equipped with a “Closed Center” hydraulic system, revision to the plumbing at the control valve bypass should be made. Refer to the tractor operator’s manual or consult your local tractor dealer to make sure which system the tractor is equipped with. (See Figure 54.)

To convert to “Closed Center” hydraulic system, revise as shown. (See Figure 54.) **When revised for “Closed Center” operation, do not use on a tractor with “Open Center”.**

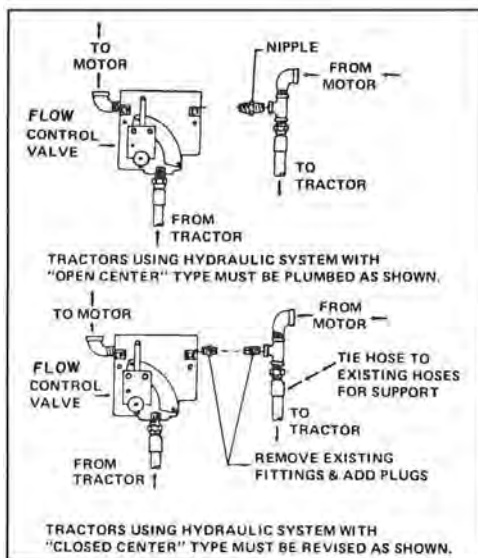


Figure 54 - Open And Closed Hydraulic Systems.

### CONVERTING TO CLOSED CENTER HYDRAULICS

To convert the hydraulic system to “Closed Center” perform the following: (See Figure 54.)

1. At the control valve upper right corner, disconnect the hydraulic hose from the motor.
2. Disconnect the hydraulic hose to tractor from the tee and elbow then remove the nipple.
3. Install the plugs in the valve and tee where the nipple was removed.
4. Connect the hydraulic hoses to the tee and elbow.
5. Tie the hoses together for additional support.

### WHEEL BEARINGS

Raise the frame and make sure it is blocked securely so the wheels may turn freely (make sure the opposite wheel is also blocked securely). To tighten the wheel bearing, remove the hub cap. Remove the cotter pin from the slotted nut and tighten the slotted nut while rotating the wheel. Loosen or back-off the nut to the nearest slot, insert and spread the cotter pin.

There should be a slight drag on the bearing following the adjustment. Replace the hub cap. (See Figure 55.)



Figure 55 - Wheel Bearing Adjustment.

## LUBRICATION



**CAUTION: BEFORE LUBRICATING THE MACHINE, MAKE SURE THE ENGINE IS SHUT OFF, PLACE THE KEY IN YOUR POCKET AND DISCONNECT THE IMPLEMENT INPUT DRIVELINE**

The CattleMaxx is designed to require a minimum amount of lubrication. The points that are to be lubricated should be serviced regularly at the specified intervals listed in this manual.

Keep your supply of lubricating oil and grease in clean containers and covered to protect them from dust and dirt.

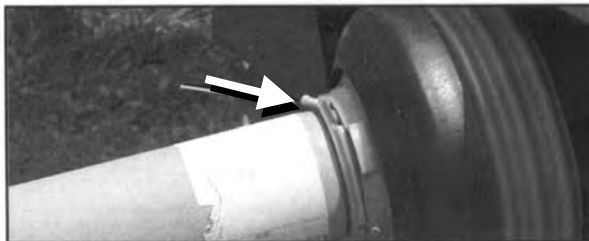
Keep the lubricating gun nozzle clean and free from dirt at all times. Wipe all of the dirt from the grease fittings before lubricating them.

### PTO DRIVELINE

Grease the bearing crosses, telescoping, and plastic shield rotation every 20 hours. The zerk is located on the sliding shaft. (See Figure 56 and Figure 57.)



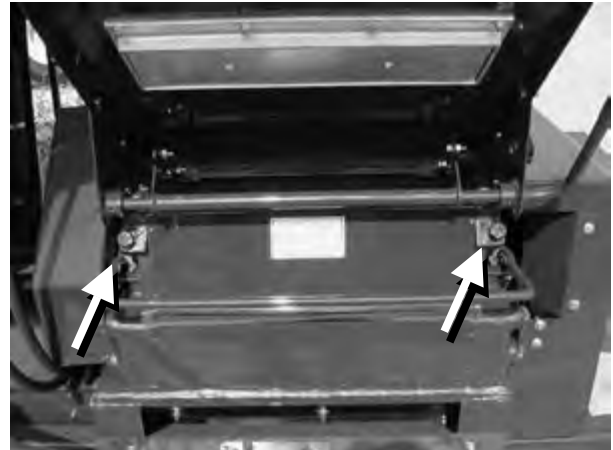
**Figure 56 - PTO Driveline (Shield Removed For Clarity).**



**Figure 57 - Plastic Shaft Bearings (See Arrow).**

### GRAIN CONTROL GATE

Grease the pivot points and slide on the grain control gate once a year or every 100 hours of operation (See Figure 58).



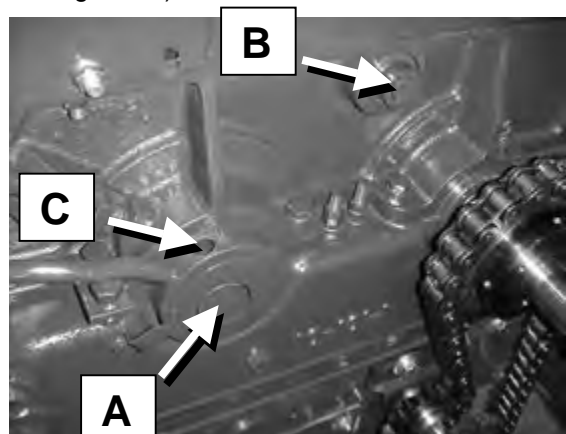
**Figure 58 - Grain Control Gate Lubrication (2 Zerks And Slide Guides).**

### ROLL BEARINGS

The rollermill roll shaft bearings are a sealed bearing and require no additional lubrication. Monitor the condition of these bearings and replace if overheating of the shaft or rollermill housing occur. New bearings are supplied with replacement rolls.

### ECCENTRIC BEARING HOUSINGS

The bearing housings on the eccentric roll shaft are greased at the factory and should not require additional lubrication under normal operating conditions. These housings should be cleaned and re-lubricated if the eccentric roll becomes hard to move or whenever the mill is torn down for service (See Figure 59).



**Figure 59 - A - Rollermill Bearings, B - Agitator Shaft Bearings, C - Eccentric Housing**

### AGITATOR SHAFT BEARINGS

The agitator shaft bearings are a sealed bearing and require no additional lubrication. Monitor the condition of these bearings and replace if overheating of the shaft or rollermill housing occur.

### ROLLERMILL BELT DRIVE

Be certain to maintain the proper belt tension on the rollermill eccentric drive, as belts will stretch during their break in period. Keep the spring-loaded idler properly tensioned and lubricated to pivot freely (See Figure 60). Improper tensioning or overloading will cause the belts to slip and causing premature wear and reduced belt life.

The idler pulley bearings on the rollermill belt drive are a sealed bearing and require no additional lubrication. Monitor the condition of these bearings and replace as necessary.



Figure 60 – Rollermill Belt Drive

### HOPPER MAGNETS

Periodically check the hopper magnets for tramp metal and debris and clean as necessary. Open the hopper lid to inspect the hopper plate magnets. Always clean the plate magnets with the throat magnet installed. Remove the throat magnet for cleaning and inspection. Be sure not to let any material from the magnets fall into the rollermill (See Figure 61).

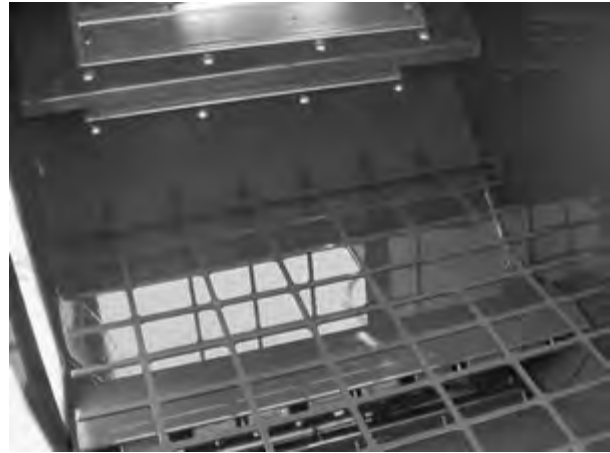


Figure 61 - Cleaning Magnets

### CHAINS

Chains should be lubricated at frequent intervals. Apply a light engine oil to the chain. Oil the chain on the inside located in the upper side of lower the strand. (See Figure 62.)

The chains should also be cleaned regularly. Remove the chains and dip or soak them in kerosene. Once the chains have been cleaned, dry and oil them thoroughly.

Oil Roller Chain on  
Upper Side of  
Lower Strand

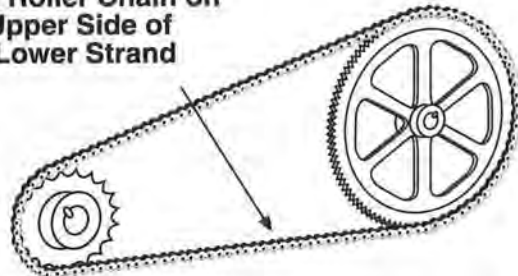


Figure 62 - Oiling Roller Chains.

The split end of the chain clip must face the direction opposite of the chain travel. Make sure the clip is properly seated in the groove on the ends of the pin. (See Figure 63.)

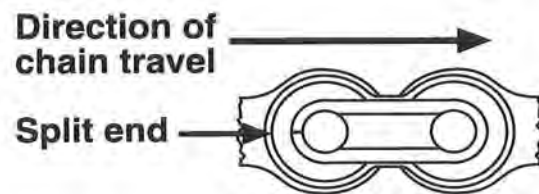


Figure 63 - Chain Spring Clip.

**GEARBOX**

Make sure to check the oil level on the gearbox at the base of the mixing tank every 6 months by removing the check plug at the front of the gearbox. Add SAE 90 weight gear oil if necessary and until oil runs out of the check hole. (See Figure 64.)

**IMPORTANT:** Do not overfill.

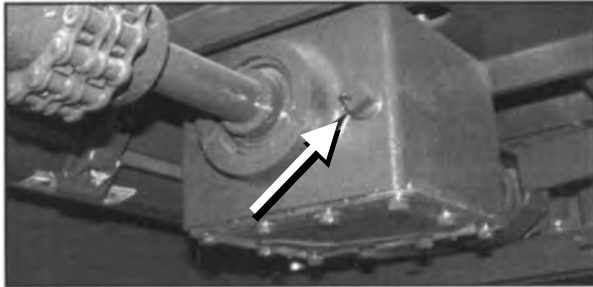


Figure 64 - Gearbox Lubrication.

**LOWER VERTICAL MIXING AUGER**

Refill the grease seal at the bottom of the vertical mixing auger every six months with SAE multi-purpose type grease. Access to this fitting can be gained through the clean-out door in the mixing tank cone, below the large bottom flight of the mixing auger. (See Figure 65.)



Figure 65 - Clean-Out Door in Mixing Tank Cone And Grease Zerk For Seal At Bottom Of Vertical Mixing Auger.

**UPPER VERTICAL MIXING AUGER**

Grease the upper vertical mixing auger bearing weekly or every 10 hours of operation with SAE multi-purpose type grease. Access to this bearing can be gained through the top of the mixing tank. (See Figure 66.)

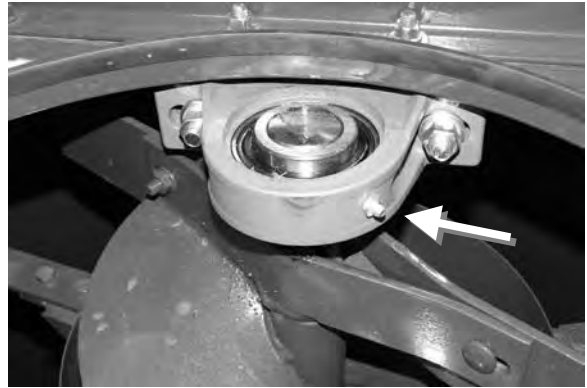


Figure 66 - Upper Vertical Mixing Auger Bearing.

**TANK VENT**

The mixing tank is vented through the left ladder rail (right-hand when facing ladder). Periodically blow air through this tube and check the opening in the tank to ensure that the vent is clear of dust and debris. A clogged tank vent may cause the spring loaded tank lid to open or windows to pop out from the side of the CattleMaxx (See Figure 67).



Figure 67 - Left Ladder Vent (Right-Hand When Facing Ladder).

**UNLOADING AUGER CLUTCH**

Apply SAE multi-purpose grease to the shaft and groove in the under sliding (driven) unloading auger clutch half. This should be done periodically to ensure proper lubrication. (See Figure 68.)

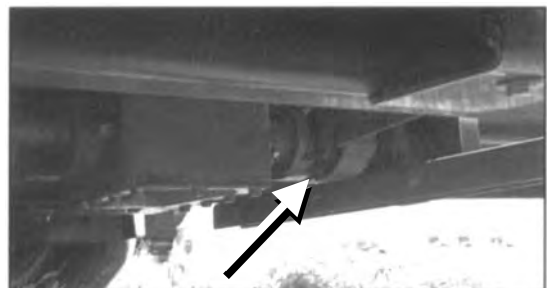


Figure 68 - Unloading Clutch Operation.

### **SWIVEL CLAMP**

Grease the lower swivel clamp every week to ensure the swivel clamp is properly lubricated. (See Figure 69.)

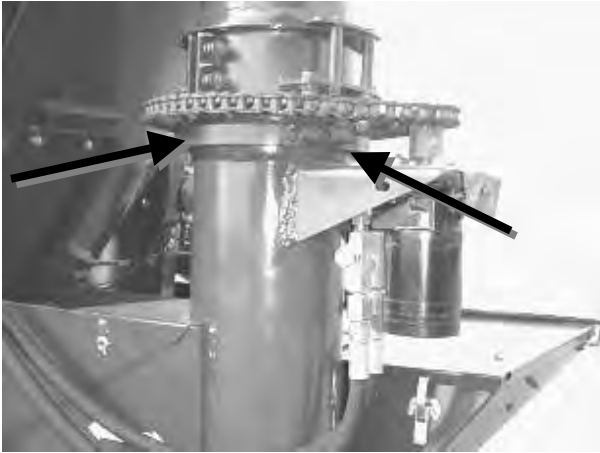


Figure 69 - Swivel Clamp Area, Discharge Auger (Shield Removed For Clarity).

### **ELBOW**

Periodically grease the gear sets at each unloading auger transfer point using SAE multi-purpose grease every 20 hours (See Figure 70, and Figure 71).



Figure 70 - Discharge Auger Bevel Gears, Inner Elbow (Shields Removed For Clarity).



Figure 71 - Discharge Auger Bevel Gears, Outer Elbow (Shields Removed For Clarity).

### **RING AND WORM GEAR (MECHANICAL)**

Grease at two locations on large ring gear for unloading auger lift pivot (See Figure 72). On units with mechanical back auger, apply grease at ring gear and worm gear periodically. Use SAE multi-purpose type grease.



Figure 72 - Ring And Worm Gear Bearings

### **WHEELS**

Remove, clean, and repack the wheel bearings once a year or every 100 hours of operation using SAE multi-purpose type grease. (See Figure 73.)



Figure 73 - Wheel Bearing Lubrication.

# SERVICE

## TORQUE SPECIFICATIONS



**CAUTION: DISENGAGE ALL DRIVES AND MAKE SURE THE TRACTOR ENGINE IS SHUT OFF. PLACE THE KEY IN YOUR POCKET AND DISCONNECT THE PTO DRIVELINE PRIOR TO SERVICING THE GRINDER MIXER.**

When performing service on the CattleMaxx and its components, take time to use and comply with the torque specification guide. (Refer to Table 6.)

Size	Clamp Load	Plain GR 5	Plated GR 5
1/4 – 20 (.250)	2,025	8 ft. lbs.	76 in. lbs.
5/16 – 18 (.3125)	3,338	17 ft. lbs.	13 ft. lbs.
3/8 – 16 (.375)	4,950	31 ft. lbs.	23 ft. lbs.
7/16 – 14 (.4375)	6,788	50 ft. lbs.	37 ft. lbs.
1/2 – 13 (.500)	9,075	76 ft. lbs.	57 ft. lbs.
9/16 – 12 (.5625)	11,625	109 ft. lbs.	82 ft. lbs.
5/8 – 11 (.625)	14,400	150 ft. lbs.	112 ft. lbs.
3/4 - 10 (.750)	21,300	266 ft. lbs.	200 ft. lbs.
7/8 – 9 (.875)	29,475	430 ft. lbs.	322 ft. lbs.
1 – 8 (1.00)	38,625	644 ft. lbs.	483 ft. lbs.
1-1/8 – 7 (1.125)	42,375	794 ft. lbs.	596 ft. lbs.

**Table 6 - Torque Specification Guide For Grade 5 Bolts.**

## SHEAR BOLTS



**WARNING: SHEAR BOLTS MAKE A LOUD NOISE WHEN SHEARED. IMMEDIATELY SHUT THE TRACTOR IGNITION OFF AND DETERMINE THE CAUSE OF SHEARING.**

Shear bolts will make a loud noise when they shear. This is your warning to turn off the tractor ignition immediately and determine the cause of the shear.

Shear bolt locations on the CattleMaxx are:

- The PTO driveline shear clutch
- The mixer drive #80 sprocket on the lower drive shaft

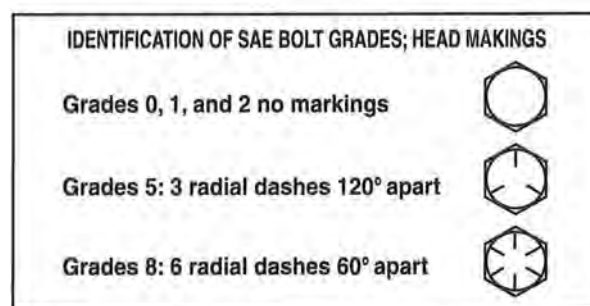
- The mill to mixer and supplement auger drive #40 sprocket on the lower driveshaft
- Discharge auger drive clutch on the gearbox output shaft.

Drive	Location	Bolt/Pin	Part No.
PTO Driveline	PTO Shear Clutch	Bolt, M10-1.5 x 60 (metric)	407760
Mixer Drive	#80 Sprocket, Lower Driveshaft	Bolt, 1/4-20 x 1-1/2 Grade 5	047000
Mill To Mixer Auger	#40 Sprocket, Lower Driveshaft	Bolt, 1/4-20 x 1 Grade 5	042960
Discharge Auger	Rear Drive Clutch	Clevis Pin, 3/8 X 2-3/8	041540

**Table 7 - Replacement Shear Bolts**

If these designed shear points are not the problem then most likely a sheared keyway in an individual components is the problem. Clear the obstruction that caused the overloading and repair/replace components as necessary.

When replacing sheared bolts, always tighten them securely using lock nuts. The shear bolts must be the correct harness to ensure safety. (See Figure 74.)



**Figure 74 - SAE Bolt Identification.**

## SPROCKET AND CHAIN ALIGNMENT

Make sure the sprockets are in line with each other. (See Figure 75 and Figure 76.) If the sprockets are not aligned a sideways pull will develop and will concentrate the load on sides of the sprocket teeth and on the side of the chain. (See Figure 76.) This faulty alignment will result on excessive wear on both the chain and sprockets.

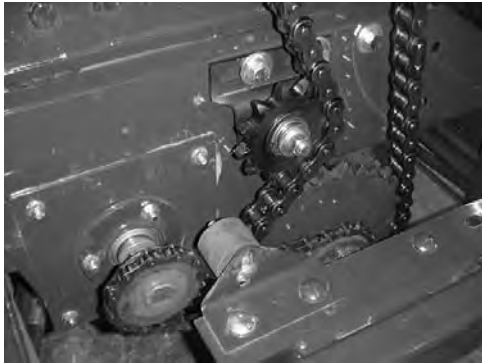


Figure 75 – Sprocket And Chain Alignment

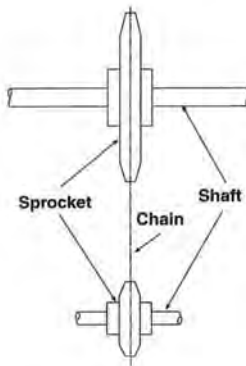


Figure 76 - Sprocket Alignment.

### REPLACEMENT ROLLS

Worn rolls can be replaced with either new rolls or regrooved rolls. A deposit must be made on the purchase of regrooved rolls. This deposit is refundable upon the return of the worn rolls and inspection by Art's-Way deeming that the returned rolls can be regrooved. Rejection of used rolls will be for such things as excessive wear (minimum roll diameter) or cracked/broken rolls.

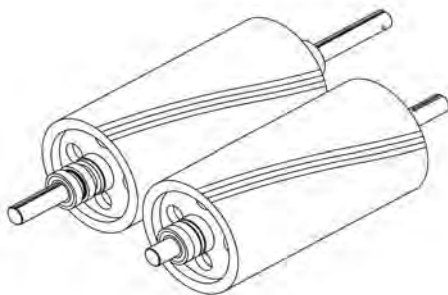


Figure 77 - Replacement Rolls Supplied With Shaft And Bearings On 20 Inch Rolls Only

### ROLL REPLACEMENT

When using roll combinations with different grooves (sharp to sharp or flat to flat) the coarser grooved roll is the drive roll. When combining sharp and flat rolls with same number of grooves, the drive roll is the sharp roll. Ensure rolls and shafts are the proper combination before installing.

Replacement 20 inch rolls are supplied with shafts and bearings. Replacement 30 inch rolls are shipped without the bearings and shafts as they attach to the shafts with taper lock hubs. To replace the rolls, perform the following:

1. Remove the PTO, front and rear guards, rear belts drive, and front drive chain.
2. If the CattleMaxx is equipped with an auger feeder, remove the pivot pin at the top of the hopper and support the auger feeder off to the side.
3. Remove the 4 bolts on the front and rear roller mill castings that hold the top and bottom halves of the mill together. Lift the top half off in one assembly. Pick up and save the two brass plugs that were in the upper castings beneath the eccentric tightener bolts.
4. Lift out the rolls and remove any pulleys, sprockets, and bearing housings. For 20 inch rolls leave the old shaft and bearings with the worn rolls. For 30 inch rolls remove shaft and taper lock hubs. The roll handle is a press fit into the bearing housings. Use care when removing the bearing housings as they can be easily damaged by hammer blows.
5. Thoroughly clean the machined surfaces of the top and bottom castings. Press the bearing housing onto the new roll assemblies. Replace the adjusting handle on the eccentric roll.
6. Grease the outside of the bearing housings and place the roll assemblies in the bottom half of the mill. The dowel spacers in the bottom casting will position the rolls front to back.
7. Replace the top half of the mill and securely bolt into place. Check that the rolls will turn without interference and the eccentric handle will move freely.
8. Replace all pulleys, sprockets, belts, and chains as well as the two brass plugs below the eccentric lock bolts. Replace the front and rear guards.
9. Replace the auger feeder to the hopper lid if applicable.
10. Set the roll gap as described in the "adjustment" section of this manual. Set the rolls for proper minimum gap and parallelism.
11. Set the roll scrapers for the new rolls as described in the "Adjustments" section of this manual.



## TROUBLESHOOTING GUIDE

The majority of difficulties are caused by improper adjustments. When you encounter trouble, perform a systematic check of all possible adjustments using the chart that follows. If difficulties cannot be corrected by making the adjustments that follow, consult your local Art's-Way authorized dealer for further assistance.

TROUBLE	POSSIBLE CAUSE	POSSIBLE REMEDY
PTO driveline is hard to telescope and hard to connect	Shafts are twisted due to overloading of the mill	Replace PTO driveline if necessary. Check for proper shear bolt in PTO shear clutch.
	Lack of grease on the sliding halves	Lubricate as necessary
	Tractor drawbar improperly adjusted.	Adjust tractor drawbar.
Excessive noise when turning the mixer while it is in operation	Turning the mixer too sharply	Avoid sharp turns
	Lack of grease on sliding halves	Lubricate as necessary
	Tractor drawbar improperly adjusted	Adjust tractor drawbar.
Tractor engine RPM falls below the rated PTO speed while grinding	Overloading mill	Close grain control gate.
	Drive belts too loose	Tighten belts
	Drive belts wore	Replace drive belts.
	Material packing on rolls	Adjust scrapers Open roll gap Install roll speed differential.
Shear pins break	Foreign objects and debris (nuts, bolts, etc.) in mill, mixers, or augers	Remove foreign objects.
	Grain in mill on start-up	Open eccentric roll to let grain flow through. Clean material from rolls.
	High RPM starts and stops	Lower RPM PTO engage and disengage. Gradually speed up and slow down.
Mill vibrates excessively while in operation	PTO driveline is not properly aligned	Front of CattleMaxx main shield must be parallel to tractor axle
	PTO driveline is bent	Replace the PTO driveline
	Overloading mill (low rumbling)	Close down grain control gate/open roll gap.
	Tractor drawbar is not adjusted properly	Adjust the tractor drawbar.
Rollermill loses capacity	Grain gate open too far	Close grain control gate
	Material packing on rolls – high moisture material	Adjust roll scrapers
	Rolls are worn, gouged, and smooth	Replace with new or regrooved rolls.

TROUBLE	POSSIBLE CAUSE	POSSIBLE REMEDY
Rolls making load or unusual noises	Rolls are touching	Check roll gap and adjust as needed.
	Roll scrapers touching rolls	Adjust roll scrapers
	Overloading mill (low rumbling)	Close down control gate/open roll gap.
Rollermill suddenly chokes	Material packed on the rolls – high moisture material	Clean rolls. Adjust roll scrapers Install roll speed differential.
Mill will not maintain roll gap setting	Eccentric lock bolts loose	Tighten lock bolts
	Brass shear plug worn or missing	Inspect and/or replace shear plug. Clean knurled surface of eccentric bearing housing.
Drive belt squeals when the mill is engaged	PTO drive may not be fast enough	Speed up tractor to 540 RPM
	Drive belts are too loose	Tighten the drive belts
	Drive belts worn	Replace drive belts
	Material packed on rolls	Open roll gap Clean rolls Adjust roll scrapers
	Overloading mill	Close down grain control gate
Drive belts show excessive wear	Belts are out of alignment	Align the pulleys
	Belts are slipping	Tighten belts.
Whole grain kernels in feed	Large roll gap	Adjust belts.
	Rolls out of parallel	Check roll parallelism and adjust as needed.
	Eccentric roll moving/increased roll gap	Tighten eccentric lock bolts Check and replace brass shear plug as needed Clean knurled surface of eccentric bearing housing.
	Rolls worn	Inspect rolls and replace as needed.
Material bridges in the tank	High moisture content material	Process high moisture material last or run straight through tank.
Mill runs but unloading auger and mixing auger do not run	Pin(s) sheared in drive	Correct cause of sheared pin and replace.
Unloading auger runs but feed is not unloading	Mixer tank door closed	Open door
	Mixer auger not turning	Check for sheared key in lower gearbox.
Auger feeder does not engage	Hydraulic flow control valve disengaged	Engage flow control valve
	Selector valve position	Change position of selector valve (OUT for auger feeder).

## ATTACHMENTS

### ELECTRONIC SCALE ATTACHMENT

A solid state electronic scale attachment, digital type, is available for your grinder mixer. The scale attachment consists of weigh bar sensors mounted on the CattleMaxx axle spindles and hitch. They are electronically connected to the indicator bars. The indicator alarm system is available with the electronic scale attachment. Scale accuracies of one percent or less are obtained. Complete installation and operating instructions are included with the attachment.

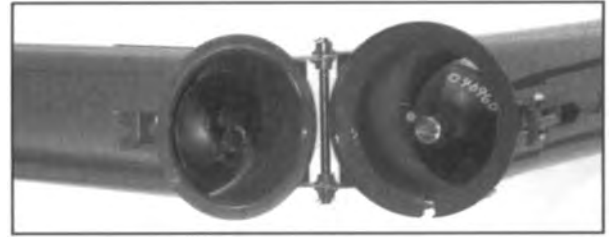


Figure 79 - Folding Auger Extensions.

### ADJUSTABLE SCALE ARM ATTACHMENT

The optional scale arm allows the electronic scale to be positioned along a 180° arc off the side of the grinder. (See Figure 78.) Tension on the pivot point spring can be increased or decreased by tightening or loosening the nut. Periodic grease needs to be applied to the zerk on the pivot point.

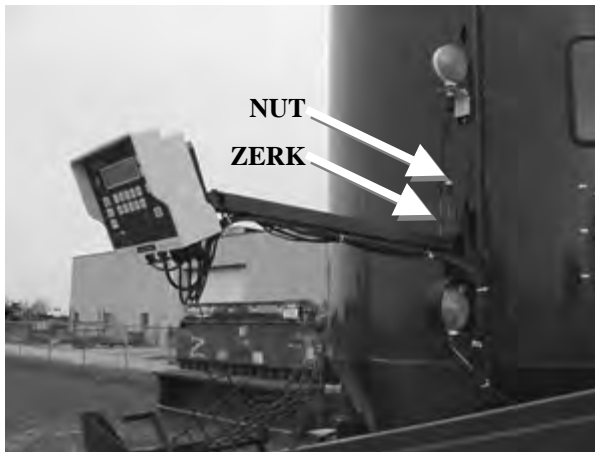


Figure 78 - Adjustable Scale Arm Attachment

### DISCHARGE UNLOADING AUGER EXTENSIONS

3 and 6 foot folding and 3 and 6 foot bolt-on discharge auger extensions are available (See Figure 79). For unloading height obtainable with various extensions added to the unloading auger system, refer to Table 5. For unloading auger instructions, refer to OPERATION OF section.

Additional spring tension needed on lift assist. Refer to LIFT ASSIST SPRING ADJUSTMENT Section (pg. 31).

## SPECIFICATIONS

### TANK AND FRAME

	<b>CattleMaxx 5105</b>	<b>CattleMaxx 5165</b>
Capacity of mixing tank	105 bushel (129 cu. ft.)	165 bushel (206 cu. ft.)
Height (variable with tire size)	106 inches	126 inches
Width with auger feeder	95 inches	111 inches
Overall length	170 inches	175 inches
Weight	3,560 lbs.	4,450 lbs.

### Discharge Auger

Auger length (standard)	125 inches	125 inches
Auger diameter	7 inches	7 inches
Auger tube diameter	8 inches	8 inches
10 inch main auger at 60 degree angle	16 ft. 7 inches	17 ft. 8 inches
Horizontal operating arc	324 degrees	316 degrees
Vertical operating arc	Infinite	Infinite

### Auger Feeder

Auger length	117 inches	117 inches
Auger diameter	7 inches	7 inches
Auger hopper width	23 inches	23 inches
Height of hopper from ground in down position	17.5 inches	17.5 inches
Height of hopper from ground in up position	42 inches	42 inches

### Mixing Auger

Auger width	12 inches	12 inches
Mixing base	24 inches	24 inches

### Supplement Hopper

Auger diameter	7 inches	7 inches
Hopper size	21 inches X 24 inches	21 inches X 24 inches
Height from ground	34 inches	39 inches

### Rollermill (Rolls are regroovable)

Width of Mill	20 inches	20 or 30 inches
Roll diameter	10 inches	10 inches
Operating speed of PTO	540 RPM	540 RPM
Operating speed of mill	540 RPM	540 RPM
Roll grooves available	5, 7, and 10	5, 7, and 10
Type of drive	PTO direct	PTO direct
Power required	50 hp.	50 hp for 20 inch 80 hp for 30 inch



## **ART'S-WAY MANUFACTURING CO., INC. TECHNICAL MANUALS**

Manuals are available from your local dealer or Art's-Way Manufacturing Co., Inc. for the operation, service, and repair of your machine. For prompt convenient service, contact your local dealer for assistance in obtaining the manuals for your machine.

Your local dealer can expedite your order for operator manuals, illustrated parts catalogs, service manuals, and maintenance records.

Always give the Machine Name, Model, and Serial Number so your local dealer can provide the correct manuals for your machine.

Art's-Way Manufacturing Co., Inc. reserves the right to make improvements in design or changes in specifications at any time without incurring any obligation to install them on units previously sold.

Except as expressly authorized, no part of this manual may be reproduced, copied, transmitted, disseminated, downloaded or stored in any storage medium, for any purpose without the express prior written consent of Art's-Way Manufacturing Co., Inc.

**ART'S-WAY MANUFACTURING CO., INC.  
HWY 9 WEST - PO Box 288  
Armstrong, IA. 50515 U.S.A**

© Copyright 2004

ART'S-WAY MANUFACTURING CO., INC.

All Rights Reserved

Produced And Published In The U.S.A. By



**CPS DYNAMICS, LLC**

PO Box 9007  
Wichita, KS 67205  
[www.cpsdynamics.com](http://www.cpsdynamics.com)



**Art's-Way Manufacturing Co., Inc.**  
**Hwy 9 West – PO Box 288**  
**Armstrong, IA. 50515 U.S.A**