



Art's-Way Manufacturing Co., Inc.

Model 6530
Grinder Mixer

Operator's Manual
593980
Issued 06-2015

O P E R A T O R ' S M A N U A L



*This symbol means **ATTENTION! BECOME ALERT! YOUR SAFETY IS INVOLVED.** The message that follows the symbol contains important information about your safety. Carefully read the message. Make sure you fully understand the causes of possible injury or death.*

IF THIS MACHINE IS USED BY AN EMPLOYEE, IS LOANED, OR IS RENTED, MAKE SURE THAT THE OPERATOR UNDERSTANDS THE TWO INSTRUCTIONS BELOW.

BEFORE THE OPERATOR STARTS THE ENGINE:

1. GIVE INSTRUCTIONS TO THE OPERATOR ABOUT SAFE AND CORRECT USE OF THE MACHINE.
2. MAKE SURE THE OPERATOR READS AND UNDERSTANDS THE OPERATOR'S MANUAL FOR THIS MACHINE.

WARNING

IMPROPER OPERATION OF THIS MACHINE CAN CAUSE INJURY OR DEATH.

BEFORE STARTING THE ENGINE, DO THE FOLLOWING:

1. READ THE OPERATOR'S MANUAL.
2. READ ALL SAFETY DECALS ON THE MACHINE.
3. CLEAR THE AREA OF OTHER PERSONS.

LEARN AND PRACTICE SAFE USE OF MACHINE CONTROLS IN A SAFE AND CLEAR AREA BEFORE YOU OPERATE THIS MACHINE ON A JOB SITE.

It is your responsibility to observe pertinent laws and regulations and to follow manufacturer's instructions on machine operation and maintenance.

See your Authorized Art's-Way Manufacturing Co., Inc. dealer or Art's-Way Manufacturing Co., Inc. for additional operator's manuals, illustrated parts catalogs, and service manuals.

TO THE OWNER

Congratulations on the purchase of your new Art's-Way 6530 Grinder Mixer. You have selected a top quality machine that is designed and built with pride to ensure you have many years of efficient and reliable service.

Many people have worked on the design, production, and delivery of this 6530 Grinder Mixer. The information in this Manual is based on the knowledge, study, and experience through years of specializing in the manufacturing of farm machinery. This Manual is designed to provide you with important information regarding safety, maintenance, and machine operation so you can and will get the best possible performance from your 6530 Grinder Mixer.

Even if you are an experienced operator of this or similar equipment, we ask that you **read this manual before operating the 6530 Grinder Mixer.** The way you operate, adjust, and maintain this unit will have much to do with its successful performance. Any further questions you may have about this product of Art's-Way equipment should be directed to your local Art's-Way dealer or to Art's-Way Manufacturing Co., Inc., Armstrong, Iowa, 50514, (712) 864-3131.

SPECIFICATIONS AND DESIGN ARE SUBJECT TO CHANGE WITHOUT NOTICE

Art's-Way Manufacturing Co., Inc. is continually making product improvements. In doing so, we reserve the right to make changes and/or add improvements to our products without obligation for the equipment previously sold.

Modifications to this 6530 Grinder Mixer may affect the performance, function, and safety of its operation. Therefore, no modifications are to be made without the written permission of Art's-Way Manufacturing Co., Inc. Any modification made without the written permission of Art's-Way Mfg. Co. shall void the warranty of this product.

In the interest of continued safe operation of this 6530 Grinder Mixer, pay particular attention to the safety alert symbol(s) throughout this Manual.

ART'S-WAY MANUFACTURING CO., INC. STATEMENT OF PRODUCT LIABILITY

Art's-Way Manufacturing Co., Inc. recognizes its responsibility to provide customers with a safe and efficient product. Art's-Way Manufacturing Co., attempts to design and manufacture its products in accordance with all accepted engineering practices effective at the date of design. This statement should not be interpreted to mean that our products will protect against the user's own carelessness or failure to follow common safety practices nor will Art's-Way Manufacturing Co., be liable for any such act. In addition, Art's-Way Manufacturing Co. assumes no liability for any altered product or any modified product by users or anyone other than an authorized dealer.

IMPORTANT WARRANTY INFORMATION

The warranty for this 6530 Grinder Mixer appears on page 3 of this Manual. In order to establish proper warranty registration, the Warranty Registration must be completed and returned to the factory. Failure to comply with this requirement may result in reduced warranty allowances.

LIMITATIONS OF THIS MANUAL

This Manual contains operating instructions for your 6530 Grinder Mixer only. Any mention of other machinery in this manual other than the 6530 Grinder Mixer is for reference only. This manual does not replace nor is it to be used for any machinery that may be attached to or used in conjunction with the 6530 Grinder Mixer.

PARTS & SERVICE

As the purchaser of your new 6530 Grinder Mixer, it is very important to consider the following factors:

- A. Original Quality
- B. Availability of Service Parts
- C. Availability of Adequate Service Facilities

Art's-Way Manufacturing Co., Inc. has an excellent dealership network ready to answer any questions you may have about your 6530 Grinder Mixer. Parts for your machine may be ordered through our dealers. When placing a parts order, please have the **model** and **serial number** ready. This will allow the dealer to fill your order as quickly as possible.

For your convenience, we have provided this space for you to record your model number, serial number, and the date of purchase, as well as your dealer's name and address.

Owner's Name: _____

Owner's Address: _____

Purchase Date: _____

Dealership Name: _____

Dealership Address: _____

Dealership Phone No.: _____

6520 Grinder Mixer Serial Number Location

The placard containing the serial and model number is located on the front left-hand side of the 6520 grinder mixer next to ladder. Enter the serial and model number of your 6520 grinder mixer within the space provided.



Figure 2 - Serial Number Placard.

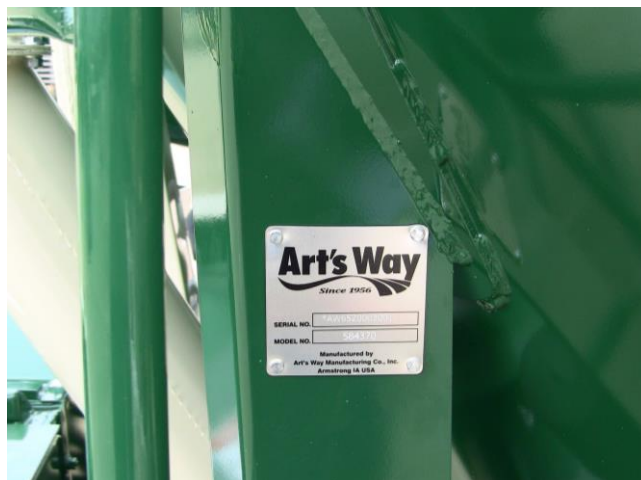

Figure 1 - Serial Number Placard Location.

TABLE OF CONTENTS

TO THE OWNER	1	ROLL FEED	24
SPECIFICATIONS AND DESIGN ARE SUBJECT TO CHANGE WITHOUT NOTICE.....	1	FOLDING AUGER EXTENSION	24
ART'S-WAY MANUFACTURING CO., INC. STATEMENT OF PRODUCT LIABILITY	1	UNLOADING AUGER HOOD.....	25
IMPORTANT WARRANTY INFORMATION.....	1	AUGER FEED OPERATION.....	25
LIMITATIONS OF THIS MANUAL	1	AUGER FEED POSITIONER	26
PARTS & SERVICE.....	2	AUGER FEED POSITIONER LOCKING PLATE	27
TABLE OF CONTENTS	3	AUGER FEED CONTROLS.....	27
LIMITED WARRANTY	5	TRACTOR HYDRAULIC AUGER FEED CONTROLS.....	27
SAFETY FIRST.....	6	GRINDER MIXER ADJUSTMENTS.....	28
NOTICES OF DANGER, WARNING, AND CAUTION	6	DRIVE CHAIN ADJUSTMENTS.....	28
SAFETY GUIDELINES	7	MAIN DRIVE CHAIN	28
BEFORE OPERATING	7	MAIN DRIVE BELTS	28
DURING OPERATION	7	HAMMER MILL DOOR	29
MAINTENANCE SAFETY	7	HYDRAULIC SWING ADJUSTMENT	30
HYDRAULIC SAFETY	8	SWIVEL STOP.....	30
TRANSPORTATION SAFETY	8	SWIVEL STOP ADJUSTMENT	30
STORAGE SAFETY	8	DISCHARGE AUGER DRIVE ADJUSTMENT.....	30
TIRE SAFETY	8	DISCHARGE AUGER HEIGHT SETTINGS	31
ASSEMBLY SAFETY.....	9	OPEN AND CLOSED CENTER TRACTOR HYDRAULICS	32
SAFETY DECALS	10	WHEEL BEARINGS	32
DECAL LOCATIONS & IDENTIFICATION.....	10	LUBRICATION.....	33
INTRODUCTION.....	13	PTO DRIVELINE	33
PREPARING THE GRINDER MIXER FOR OPERATION.....	15	HAMMER MILL SHAFT BEARINGS.....	33
TIRES.....	15	DRIVE BELT IDLER TENSIONER.....	34
GUARDS, DOORS, AND SHIELDS.....	15	HAMMER MILL ENGAGING PIN.....	34
BOLTS AND NUTS	15	DRIVE SHAFT BEARINGS	34
PREPARING THE TRACTOR.....	16	CHAINS.....	35
TRACTOR HITCH	16	GEARBOX	35
ATTACHING TO THE TRACTOR	16	LOWER VERTICAL MIXING AUGER.....	36
HAMMER MILL	17	UPPER VERTICAL MIXING AUGER	36
BEFORE GRINDING	17	DISCHARGE U-JOINT.....	36
DETACHING FROM THE TRACTOR	17	DISCHARGE PIVOT PIN	36
OPERATION OF GRINDER MIXER.....	18	WHEELS	36
TRACTOR PTO ENGAGEMENT	18	SERVICE.....	37
HAMMER MILL CLUTCH PIN.....	18	TORQUE SPECIFICATIONS.....	37
FEED GATE	18	SHEAR BOLTS	37
WEAR PLATES.....	18	SPROCKET AND CHAIN ALIGNMENT	37
HAY RETARD BOLTS.....	19	REPLACEMENT OF WORN OR DAMAGED HAMMERS	38
HAMMER MILL SCREENS.....	19	REVERSING THE HAMMERS	38
CHANGING SCREENS	20	STANDARD SPACING FOR 96 HAMMERS	38
PROCESSING HAY	21	ALTERNATE SPACING FOR 96 HAMMERS.....	39
PROCESSING WITHOUT MIXING	21	MAIN DRIVE BELT REPLACEMENT.....	39
ADDING CONCENTRATE OR SUPPLEMENT.....	21	WEAR PLATE REPLACEMENT	40
FILLING THE MIXER TANK	22	TROUBLESHOOTING GUIDE.....	41
SPRING LOADED TANK LID	22	SELF-CONTAINED: INTRODUCTION	43
DISCHARGE AUGER POSITIONING	23	SELF-CONTAINED: PREPARING FOR OPERATION	43
TRACTOR HYDRAULIC LIFT AND SWING.....	23	PREPARING THE GRINDER MIXER	44
TRACTOR HYDRAULIC SELECTOR VALVE	23	REMOTE CONTROL & RECEIVER SETUP	44
TRACTOR HYDRAULIC DISCHARGE AUGER LIFT AND SWING ADJUSTMENT	23	DISCHARGE START/STOP BUTTON LATCHING MODE	44
DISCHARGE GATE FUNCTION.....	24	SYNCHRONIZING RECEIVER TO REMOTE CONTROL	45
TRACTOR HYDRAULIC ACTUATOR CONTROL	24	RESETTING REMOTE CONTROL SLEEP/SHUTOFF TIME	45
		COMPLETE CONTROL BOX AS BACKUP REMOTE CONTROL BOX	46
		HYDRAULIC COMPONENTS.....	46
		SELF-CONTAINED: OPERATION	47
		DISCHARGE AUGER LIFT CYLINDER ADJUSTMENT	49

DISCHARGE AUGER SWING MOTOR ADJUSTMENT.....	49	AUGER FEEDER.....	57
DISCHARGE AUGER LIFT CYLINDER AND SWING MOTOR		MIXING AUGER.....	57
PRESSURE RELIEF ADJUSTMENT	49	SUPPLEMENT HOPPER	57
HYDRAULIC SYSTEM PRESSURE RELIEF ADJUSTMENT ..	49	HAMMERMILLS.....	57
HYDRAULIC DISCHARGE AUGER SOFT SHIFT CONTROLLER			
.....	49		
SELF-CONTAINED: ADJUSTMENT/SERVICE & LUBRICATION	50	SPECIFICATIONS: SELF-CONTAINED HYDRAULICS	58
MAIN DRIVE CHAIN.....	50	PUMP	58
HYDRAULIC VALVES.....	50	HYDRAULIC RESERVOIR	58
LUBRICATION	50	FILTERS/STRAINERS/BREATHERS/ INDICATORS.....	58
HYDRAULIC FILTRATION	50	HYDRAULIC MOTORS.....	58
FILLER/BREATHER FILTER	51	MANIFOLD VALVE ASSEMBLY	58
SELF CONTAINED: TROUBLESHOOTING GUIDE.....	52	ELECTRIC ACTUATOR.....	60
SELF CONTAINED: REMOTE CONTROL ERROR CODES.....	54	ELECTRIC CONTROL BOX	60
ATTACHMENTS.....	55	WIRELESS REMOTE CONTROL.....	60
ELECTRONIC SCALE ATTACHMENT	55	SCHEMATICS: TRACTOR HYDRAULICS.....	61
ADJUSTABLE SCALE ARM ATTACHMENT	55	SCHEMATICS: SELF-CONTAINED HYDRAULICS	62
DISCHARGE UNLOADING AUGER EXTENSIONS	55	SCHEMATICS: SELF-CONTAINED WIRING	63
SCREENS	55	CONTROL BOX WITH 4 FT. WIRING HARNESS ...	63
HYDRAULIC ROLL FEED	55	WIRING HARNESS VALVE BANK, MANIFOLD, & ACTUATOR	63
ROLL FEED ADJUSTMENT	56	SCHEMATICS: SELF-CONTAINED WIRING	64
SPECIFICATIONS	57	RECEIVER 8-OUTPUT	64
TANK AND FRAME	57	OPTIONAL 20 FT. WIRE HARNESS EXTENSION .	64
DISCHARGE AUGER	57	ART'S-WAY MANUFACTURING CO., INC. TECHNICAL MANUALS	65

LIMITED WARRANTY

Art's-Way Manufacturing Co., Inc. warrants the products it sells to be free from defects in material and workmanship for a period of one (1) year after the date of delivery to the first (original) purchaser, subject to the following conditions:

- Art's-Way Manufacturing Co., Inc. obligation and liability under this warranty is to repair or replace (at the company's option) any parts that upon manufacture were defective in material or workmanship.
- All parts and repairs under this warranty shall be supplied at Art's-Way Manufacturing Co., Inc. or an authorized Art's-Way Manufacturing Co., Inc. dealer, at the option of Art's-Way Manufacturing Co., Inc.
- Art's-Way Manufacturing Co., Inc. warranty does not extend to parts and elements not manufactured by Art's-Way Manufacturing Co., Inc. and which carry the warranty of other manufacturers.
- Transportation or shipping to an authorized dealer for necessary repairs is at the expense of the purchaser.
- Art's-Way Manufacturing Co., Inc. makes no other warranty expressed or implied and makes no warranty of merchantability or fitness for any particular purpose beyond that expressly stated in this warranty. Art's-Way Manufacturing Co., Inc. liability is limited to the terms set forth in this warranty and does not include any liability for direct, indirect, incidental or consequential damages or expenses of delay and the Company's liability is limited to repair or replacement of defective parts as set forth herein.
- Any improper use and/or maintenance, including operation after discovery of defective or worn parts, operation beyond the rated capacity, substitution of parts not approved by Art's-Way Manufacturing Co., Inc., or any alternation or repair by other than an authorized Art's-Way Manufacturing Co., Inc. dealer which affects the product materially and adversely, shall void the warranty.
- No dealer, employee or representative is authorized to change this warranty in any way or grant any other warranty unless such change is made in writing and signed by an officer of Art's-Way Manufacturing Co., Inc.
- Some states do not allow limitations on how long an implied warranty lasts or exclusions of, or limitations on relief such as incidental or consequential damages, so the above limitations or exclusions may not apply to you. This warranty gives you the specific legal rights and you may have other rights that vary from state to state.

SAFETY FIRST

“A careful operator is the best insurance against an accident”

(National Safety Council)

Most accidents can be prevented if the operator:

- Fully understands how the machine functions
- Can anticipate situations which may produce problems
- Can make necessary corrections before problems develop



**THIS SYMBOL MEANS
ATTENTION!
BECOME ALERT!
YOUR SAFETY IS INVOLVED!**

Figure 3 - Universal Safety Alert Symbol.

The American Society of Agricultural Engineers has adopted the Universal Safety Alert Symbol as a way to identify areas of potential danger if the equipment is not operated correctly (see Figure 3). Please be alert whenever you see this symbol in the manuals or on your Grinder Mixer.

Art's-Way Manufacturing Co., Inc. strives to make our equipment as safe as possible. The Art's-Way 6530 Grinder Mixer conforms to applicable safety standards at the time of manufacturing. A safety conscious equipment operator makes an effective accident-prevention program complete.

Safety features and instructions for the Grinder Mixer are detailed in the section of this Operator's Manual. It is the responsibility of the owner to ensure that all operators read and understand the manual before they are allowed to operate the Grinder Mixer. (Occupational Safety and Health Administration (OSHA) regulations 1928.57.)

NOTICES OF DANGER, WARNING, AND CAUTION

Signal Words: Note the use of signal words **DANGER**, **WARNING**, and **CAUTION** on the Grinder Mixer and in this manual. The appropriate signal word for each has been selected using the following guidelines:



DANGER: IMMEDIATE AND SPECIFIC HAZARD WHICH WILL RESULT IN SEVERE PERSONAL INJURY OR DEATH IF PROPER PRECAUTIONS ARE NOT TAKEN.



WARNING: SPECIFIC HAZARD OR UNSAFE PRACTICE COULD RESULT IN SEVERE PERSONAL INJURY OR DEATH IF PROPER PRECAUTIONS ARE NOT TAKEN.



CAUTION: A REMINDER OF GOOD SAFETY PRACTICES. PERSONAL INJURY COULD RESULT IF PROPER PROCEDURES ARE NOT FOLLOWED.



SAFETY GUIDELINES



Remember:

“The Best Operator is a Safe Operator”



CAUTION: READ AND UNDERSTAND THE OPERATOR'S MANUAL AND ALL THE SAFETY DECALS BEFORE OPERATING THE GRINDER MIXER. REVIEW ALL SAFETY INSTRUCTIONS WITH ALL OPERATORS ANNUALLY.

BEFORE OPERATING

- Do not wear loose fitting clothing as it may catch in moving parts.
- Make sure to install and/or secure all guards, doors and shields, including the tractor power take-off (PTO) master shield, before starting or operating the Grinder Mixer.
- Be sure that the correct implement driveline parts are used and that they are properly secured.
- Install the safety chain when attaching the Grinder Mixer to the tractor.
- Clear the area of bystanders, especially children, when making repairs, adjustments or performing maintenance on the Grinder Mixer.
- Do not allow riders.
- Put all tractor and machine controls in “neutral” and disengage the PTO before starting. Follow the starting instructions according to your tractor Manual.
- Operate the Grinder Mixer only while seated on the tractor seat.
- Make sure the unit is adequately supported with safety blocks or safety stands when changing tires or performing maintenance.



CAUTION: KEEP CLEAR OF MOVING PARTS. BE SURE TO SHUT OFF THE TRACTOR AND SET THE PARKING BRAKE. REMOVE THE TRACTOR KEY WHILE MAKING ANY ADJUSTMENTS. WAIT FOR ALL MOVEMENT TO STOP BEFORE APPROACHING THE MACHINE.

DURING OPERATION

- Keep hands, feet, hair, and clothing away from moving parts.
- Keep all guards, doors and shields in place and in good working condition.
- Keep all bystanders, especially children, away from the grinder mixer while in operation.
- Do not allow riders while the grinder mixer is in operation.
- Do not attempt to unclog, clean, or adjust the grinder mixer while it is running.
- Stay away from overhead power lines. Electrocutation can occur even without direct contact.
- Keep all hydraulic lines, fittings, and couplers tight and free of leaks. (Refer to - Hydraulic Safety.)
- Use caution when ascending or descending on the grinder mixer. Wet shoes or boots are slippery.

MAINTENANCE SAFETY

- Follow all operating, maintenance and safety instructions found in this Manual.
- Before servicing, adjusting, repairing or unclogging the machine, always make sure the tractor engine is stopped, the parking brake is set, and all the moving parts have stopped.
- Use sufficient tools, jacks, and hoists that have the capacity for the job.
- Use support blocks or safety stands when changing tires or performing maintenance.
- Follow good shop practices of keeping the service area clean and dry and use adequate light for the job at hand.
- Before applying pressure to the hydraulic system, make sure all lines, fittings and couplers are tightly secured and in good condition.
- Make sure all guards, doors and shields are in place and properly secured when performing maintenance.

HYDRAULIC SAFETY

- Make sure components in the hydraulic system are kept clean and in good working condition.
- Relieve pressure from the hydraulic system before servicing or disconnecting from the tractor.
- Keep all hydraulic lines, fittings, and couplers tightly secured and free of leaks.
- Replace any worn, cut, abraded, flattened or crimped hoses.
- Do not make any temporary repairs to the hydraulic lines, fittings or hoses using tape, clamps, or cement. The hydraulic system operates under extremely high pressure and temporary repairs may fail suddenly and create a hazardous and or dangerous situation.
- Wear proper hand and eye protection when searching for a high-pressure hydraulic leak. Use a piece of wood or cardboard as a backstop instead of hands to identify and isolate a leak. If injured by a concentrated high-pressure stream of hydraulic fluid, seek medical attention immediately. Serious infection or toxic reaction can develop if hydraulic fluid penetrates the surface of the skin.
- Before applying pressure to the system, make sure all components are tight and that the hydraulic lines, hoses, and couplings are not damaged.

TRANSPORTATION SAFETY

- Make sure the grinder mixer complies with all local regulations regarding the transportation of equipment on public roads and highways.
- Make sure the Slow Moving Vehicle (SMV) emblem and all lights and reflectors required by local highway and transportation authorities are properly in place, clean, and clearly visible to traffic.
- Do not allow riders on any machinery during transport.
- Make sure the grinder mixer is securely attached to the tractor and install a safety chain to the grinder mixer.
- Make sure the tractor brake pedals are latched together.
- Do not exceed 20 mph (32 km/h) when transporting the grinder mixer. Always reduce speed on rough roads and surfaces, or when going down inclines.

- Use caution when turning and always use the turn signals on the tractor to indicate your turning intentions to the other traffic.
- The weight of the trailed machine should NEVER exceed the weight of the towing vehicle.
- Check all clearances carefully whenever the machine is towed.
- Lower the elevator into the transport position before transporting the harvester on the highway.
- Stay away from overhead obstructions and power lines during transport. Electrocutation can occur even without direct contact.

STORAGE SAFETY

- Store the grinder mixer in an area away from human activity.
- Do not permit children to play on or around the stored machine at any time.
- Make sure that the grinder mixer is stored in an area with a firm and level base to prevent the machine from tipping or sinking into the ground.
- Block the wheels to prevent the machine from rolling.

TIRE SAFETY

- Have only a qualified tire dealer or tire repair service perform tire repairs.
- Do not attempt to install a tire on a wheel or rim unless you have the proper equipment and experience to do the job.
- Follow proper procedures when installing a tire on a wheel or rim to prevent an explosion that could result in serious injury.
- Do not substitute tires with a lesser road rating and/or capacity for the original equipment tires.



CAUTION: FAILURE TO FOLLOW PROPER PROCEDURES WHEN INSTALLING A TIRE ON A WHEEL OR RIM CAN PRODUCE AN EXPLOSION THAT MAY RESULT IN SERIOUS INJURY OR DEATH. DO NOT ATTEMPT TO INSTALL A TIRE UNLESS YOU HAVE THE PROPER EQUIPMENT AND EXPERIENCE TO PERFORM THE JOB. REPLACEMENT, REPAIR, AND/OR MAINTENANCE SHOULD BE DONE BY A QUALIFIED TIRE DEALER OR QUALIFIED REPAIR SERVICE.

ASSEMBLY SAFETY

- Use adequate manpower to perform assembly procedures safely.
- Assemble the grinder mixer in an area with sufficient space to maneuver the largest components and allow easy access to all sides of the machine.
- Use only forklifts, lift cranes, jacks and tools with sufficient capacity for the loads.
- Do not allow spectators, especially children, in the working area.

Remember:

“The Best Operator is a Safe Operator”

SAFETY DECALS

DECAL LOCATIONS & IDENTIFICATION

The different types of safety decals for your 6530 Grinder Mixer are illustrated on the following pages. Please familiarize yourself with the appearance of each decal, the warning it describes, and the area where it is located on the grinder mixer (see Figure 4, Figure 5, and Figure 6).

Safety awareness is the responsibility of each operator of the grinder mixer. Keep safety decals and signs clean and legible and be sure replacement parts display the current safety decals and signs as well.

Remember: Always replace missing, damaged or illegible safety decals. New decals and signs are available from an authorized dealer.

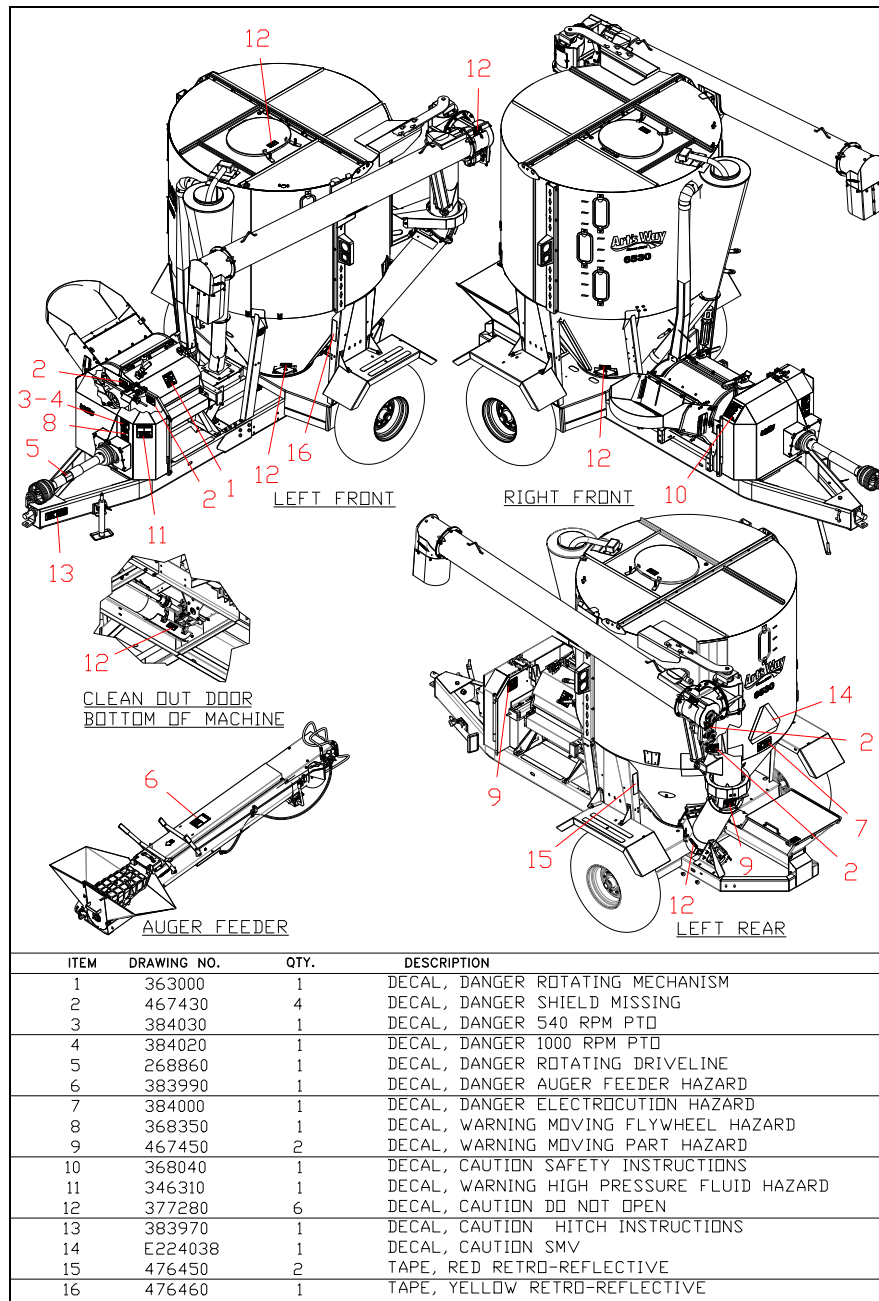

Figure 4 - Safety Decal Locations.

NOTE: Keep all decals clean and free of dirt for maximum visibility. Replace all individual decals that are no longer legible. Read and obey all safety decals and be familiar with their meaning.



1. DANGER – Rotation Mechanism (363000)



3. DANGER - 540 RPM PTO (384030)



5. DANGER – Rotating Driveline (268860)



2. DANGER - Shield Missing (467430)



4. DANGER - 1000 RPM PTO (384020)



6. DANGER – Auger Feeder Hazard (383990)

Figure 5 - Safety Decals.

NOTE: Keep all decals clean and free of dirt for maximum visibility. Replace all individual decals that are no longer legible. Read and obey all safety decals and be familiar with their meaning.



7. DANGER – Electrocutation Hazard (384000)



8. WARNING – Moving Flywheel Hazard (368350)



9. WARNING – Moving Part Hazard (467450)

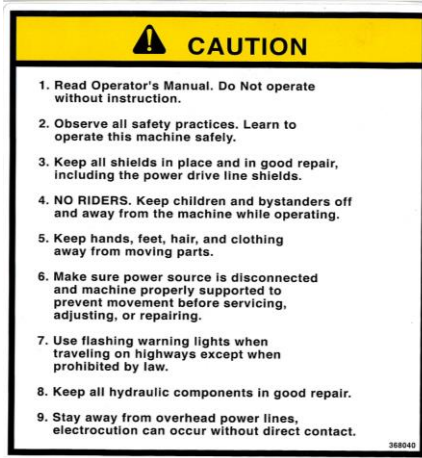

10. CAUTION – Safety Instructions (368040)



11. WARNING –High Pressure Fluid Hazard (346310)



12. CAUTION – Do Not Open (377280)

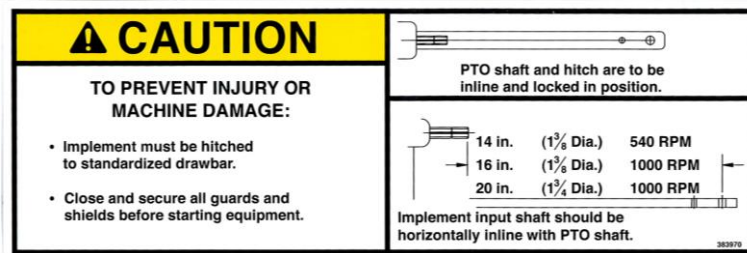

13. CAUTION – Hitch Instructions (383970)

Figure 6 - Safety Decals.

NOTE: Keep all decals clean and free of dirt for maximum visibility. Replace all individual decals that are no longer legible. Read and obey all safety decals and be familiar with their meaning.

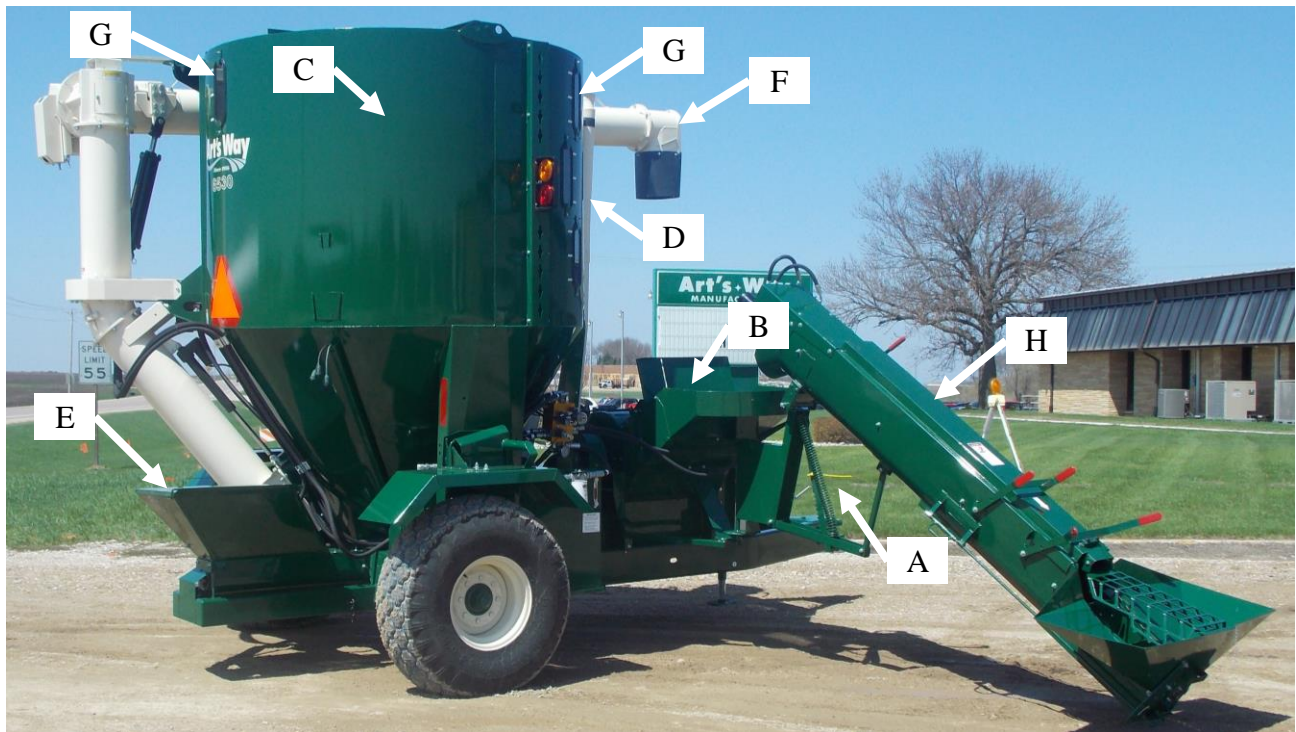

Figure 7 - Model 6530 With Auger Feeder (A – PTO Driveline; B – Hammer mill; C – Mixing Tank; D – Dust Collector; E – Supplemental Hopper; F – Unloading Auger; G – Viewing Windows; H – Auger Feeder).

INTRODUCTION

This manual has been prepared to make you familiar with the proper operation, adjustment, lubrication and service of your grinder mixer. Take time to be careful and better understand the efficient operation and care of your machine.

Whenever the terms “**Left**” and “**Right**” are used, it should be understood to mean standing behind the machine and facing the direction of forward travel.

Some pictorials are used to show guards, doors and shields removed for easy identification. Make sure that all guards, doors and shields are in place before operating the machine. They are for your protection.

The Art’s-Way 6530 Grinder Mixer is driven by a PTO driveline of 80 HP to 150 HP tractors. (Figure 7, Detail A.) When using a tractor over 150 HP, limit input. It is factory available with either a 540 or 1000 RPM drive.

Hammer mill respective speed should be maintained as the hammer mill cylinder operates best at 2800 to 3000 RPM. (Figure 7, Detail B.) Hammer mill cylinder must not exceed 3000 PRM.



CAUTION: NEVER OPERATE A 540 RPM PROCESSOR WITH A 1000 RPM TRACTOR.

Before operating your grinder mixer, select and install the screen size desired. Sizes are available from 1/8 to 2 inch openings. For screen selection guidelines, refer to OPERATION OF GRINDER MIXER – Hammer mill Screens.

All types of grain can be ground with the hammer mill. Hay can be ground with a minimum of 1/3 mixer of grain. Material is fed into the hammer mill where it is ground until it can pass through the screen size selected. From the hammer mill, the material is augered into the mixing tank. (Figure 7, Detail C.) A suction fan takes air pressure out of the hammer mill housing and delivers feed fines into the dust collector. (Figure 7, Detail D.) The fines are separated and then dropped into the mill to mixer auger.

If supplement is to be added to the ration, a hopper with a sack cutter is located at the right rear of the mixing tank. (Figure 7, Detail E – Supplement Auger.) The best mixing will result if the supplement is added before grinding.

The ground feed is mixed continuously until the tractor PTO is disengaged.

The unloading auger pivots at the left rear of the mixing tank and can swing 225 degrees on the grinder mixer in a horizontal arc. (Figure 7, Detail F.) It can also swing in a vertical arc to the limit of the lift cylinder. Unloading rates up to 50 bushels per minute can be obtained depending upon

position of the discharge and the type of material processed.

Five viewing windows are located at the front right corner of the mixing tank to observe the feed level during grinding and mixing. (Figure 7, Detail G.) A ladder is located at the front left corner of the mixing tank to gain access to the spring-loaded mixing tank lid.



CAUTION: DO NOT OPEN SPRING-LOADED MIXING TANK LID WHILE PTO IS ENGAGED AND TRACTOR IS RUNNING.

Many convenient features are standard equipment on the Art's Way 6530 grinder mixer including:

6530

1. 13.5 x 16.1 tires.
2. Magnet in the hammer mill throat.
3. Hydraulic positioning of discharge auger. This includes a hydraulic cylinder for lift and hydraulic motor for swing.
4. Positioner to enable the hopper on the auger feeder to be moved in or out 6 inches to properly position in front of the augers. (Figure 7, Detail H.)
5. Fenders.
6. Screen rack.
7. Tongue jack.
8. Discharge auger hood with spring loaded relief door.
9. Tractor run hydraulics or self-contained hydraulics with electric activated discharge and wireless remote control
10. Highway transport light kit.

Below is a list of optional attachments available:

1. 540 RPM or 1000 RPM PTO.
2. Auger feeder (hydraulic). (See Figure 87.)



Figure 8 - Model 6530 With Self-Contained Hydraulics and Auger Feeder.

3. Electronic scale, with digital readout.
4. Positioning arm for electronic scale box.
5. Horn, light, or horn and light for electronic scale.
6. Unloading auger extensions; 3 ft. or 6 ft. folding or bolt-on.
7. Hydraulic roll feed in mill throat hammer mills.
8. 20' extension harness to operate complete control box from tractor.

PREPARING THE GRINDER MIXER FOR OPERATION

Remove the shipping banding or wire from the auger feeder (if equipped), rear discharge cover and the unloading tube to saddle at the side of the tank.

IMPORTANT: Remove the bag from the supplement hopper. Place the screen hook in the hammer mill door pin (see Figure 9).



Figure 9 - Screen Hook Storage.

Install the PTO driveline storage bracket under the front hitch with 1/2 inch x 1-1/2 inch bolt and lock nut (see Figure 10). Maintain tension with the lock nut to allow movement with 15 lbs. pull.

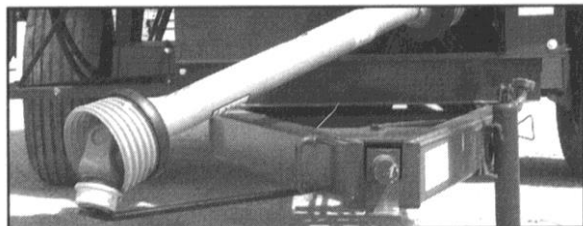

Figure 10 - PTO Driveline Storage Bracket.

If equipped with auger feeder, remove the transport locking plate (Figure 36), to use auger feeder positioner. Refer to OPERATION OF GRINDER MIXER – Auger Feeder Operation and Auger Feeder Positioner Operation.

Install any option that was ordered with the grinder mixer and shipped as loose equipment. See instructions packaged with the specific options for installation.

Install the implement end of the PTO driveline by fastening it to the input jackshaft with the 5/16 inch x 3-1/2 inch clevis pin and cotter pin provided.

Spread the cotter pin and make sure the proper PTO is used.



CAUTION: NEVER OPERATE A 540 RPM GRINDER MIXER WITH A 1000 RPM TRACTOR.

NOTE: Height of the unloading auger tube needs to be checked. Move the saddle on the side of the mixing tank so the tube will properly clear the tractor and cab.

If equipped with a folding extension, hydraulic auger feeder, or roll feed, refer to OPERATION OF GRINDER MIXER –Folding Auger Extension, Unloading Auger Hood, and Auger Feed Operation sections as well as the ATTACHMENTS section for instructions.

TIRES

Keep tires properly inflated. Lack of pressure can result in torn valve stems, fabric breaks and uneven tread wear. Too much pressure can cause undue strain on fabric, excessive tread wear and allows the tire to cut in more on wet surfaces. Equal tire pressure reduces grinder mixer sway when towing.

Recommended tire inflation pressure is as follows:

13.5 x 16.1 8 – PR tires – 28 psi

GUARDS, DOORS, AND SHIELDS

Make sure that all of the guards, doors, and shields are in place and functioning.

BOLTS AND NUTS

Cap screws, except for shear bolts, used on the grinder mixer are Grade 5 and if replaced, cap screws of equal or greater strength should be used. Grade 5 cap screws are identified by three radial dashes on the hex head. Refer to the SAE bolt identification guide (see Figure 11).

IDENTIFICATION OF SAE BOLT GRADES; HEAD MAKINGS	
Grades 0, 1, and 2 no markings	
Grades 5: 3 radial dashes 120° apart	
Grades 8: 6 radial dashes 60° apart	

Figure 11 - SAE Bolt Identification.

IMPORTANT: Shear bolts must be replaced with bolts of the same grade

Before operation of the grinder mixer, make sure all bolts and nuts are properly tightened. Make sure all cotter pins are spread and not damaged. After operation of the grinder mixer for several hours, make sure all bolts are set to proper torque. Refer to the torque guide (see Table 1).

Size	Clamp Load	Plain GR 5	Plated GR 5
1/4 – 20 (.250)	2,025	8 ft. lbs.	76 in. lbs.
5/16 – 18 (.3125)	3,338	17 ft. lbs.	13 ft. lbs.
3/8 – 16 (.375)	4,950	31 ft. lbs.	23 ft. lbs.
7/16 – 14 (.4375)	6,788	50 ft. lbs.	37 ft. lbs.
1/2 – 13 (.500)	9,075	76 ft. lbs.	57 ft. lbs.
9/16 – 12 (.5625)	11,625	109 ft. lbs.	82 ft. lbs.
5/8 – 11 (.625)	14,400	150 ft. lbs.	112 ft. lbs.
3/4 – 10 (.750)	21,300	266 ft. lbs.	200 ft. lbs.
7/8 – 9 (.875)	29,475	430 ft. lbs.	322 ft. lbs.
1 – 8 (1.00)	38,625	644 ft. lbs.	483 ft. lbs.
1-1/8 – 7 (1.125)	42,375	794 ft. lbs.	596 ft. lbs.

Table 1 - Torque Specification Guide for Grade 5 Bolts.

Lubricate the grinder mixer at regular intervals as instructed in the lubrication sections. (Refer to **LUBRICATION** section.)

PREPARING THE TRACTOR

The tractor must be equipped with a 540 or 1000 RPM PTO to match the grinder mixer as described in the previous section. Make sure the grinder mixer and the tractor are equipped and set for the proper RPM.



CAUTION: NEVER OPERATE A 540 RPM GRINDER MIXER WITH A 1000 RPM TRACTOR PTO.

TRACTOR HITCH

The hitch for the grinder mixer is designed to attach to any SAE – ASAE standardized tractor drawbar. Adjust the drawbar so it is 13 to 17 inches above the ground (see Figure 12). Extend or shorten the tractor drawbar so the horizontal distance from the end of the tractor PTO shaft to the center of the hitch pin hole is 14 inches for 540 RPM and 16 inches for 1000 RPM drives.

Lock the drawbar in its crossbar, parallel with the centerline of the PTO. Place locking pins on each side of the drawbar. If the tractor has an offset drawbar, the offset should be down for PTO work.

IMPORTANT: An improperly located hitch point may cause damage to the universal joints (U-Joints) of the PTO driveline.

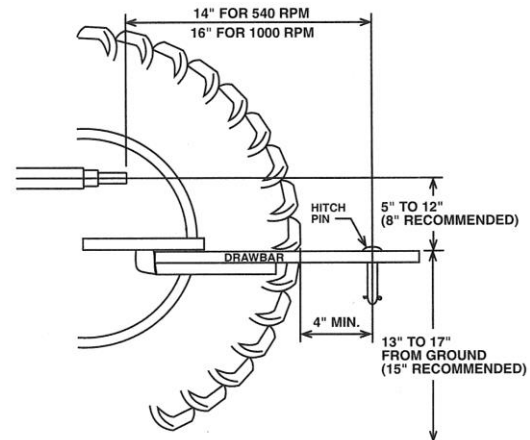

Figure 12 - Hitch Point Locations

ATTACHING TO THE TRACTOR

NOTE: Height of the unloading auger tube needs to be checked. Move the saddle on the side of the mixing tank so the tube will properly clear the tractor and cab.

Carefully back the tractor up to the hitch. Use the crank of the jack to raise or lower the grinder mixer hitch into position to engage the tractor drawbar.

Fasten the grinder mixer hitch to the drawbar with a hitch pin that cannot bounce out. Raise the jack and lock into the transport position (see Figure 13). Attach the safety chain from the grinder mixer to the tractor (see Figure 14).



CAUTION: ALWAYS FOLLOW STATE AND LOCAL REGULATIONS REGARDING A SAFETY CHAIN WHEN TOWING FARM EQUIPMENT ON PUBLIC HIGHWAYS.



Figure 13 - Jack in Transport Position



Figure 14 - Grinder Attached To The Tractor With Safety Chain.

For Electronic Scale Indicator, plug the scale power supply cord into the electrical outlet on the tractor or to the battery on the mixer frame. (Wire power cord to the battery as shown in Figure 33.)

IMPORTANT: *On electronic scale applications, if a bolt and nut are used in place of a hitch pin, the nut must not be tightened to where it hits against the underside of the weigh bar clevis.*

Connect the PTO driveline to the tractor PTO shaft. The PTO operating speed of the tractor and grinder mixer must be the same. The tractor half of the PTO is equipped with 6-splines for 540 RPM operation and 21-splines for 1000 RPM operation.

Plug 7-Pin connector for lights into tractor receptacle.

HAMMER MILL

Make sure the grinder mixer is equipped with a 1000 RPM drive when operating with a tractor equipped with a 1000 RPM PTO drive. The diameter of the pulley on the jackshaft must be 12-5/16 inches for 1000 RPM operation in a hammer mill application. The diameter of the pulley on the jackshaft must be 22-5/8 inches for 540 RPM operation in a hammer mill application (see Figure 15).

CAUTION: NEVER OPERATE A 540 RPM GRINDER MIXER WITH A 1000 RPM TRACTOR.

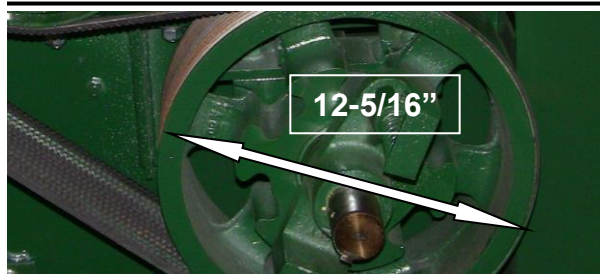

Figure 15 - Small Pulley - 1000 RPM (Shields Removed For Clarity).

After connecting the PTO driveline to the tractor, anchor the driveline implement shield chain, located in the main shield base slot, and the tractor shield chain to the tractor drawbar.

BEFORE GRINDING

New machines should be operated before preparing feed. A few hundred pounds of coarse material such as shelled corn or ground cobs should be ran through the grinder mixer. This will remove the protective oil coating from the mixer cone and any metal particles that may be in the machine. This will help polish the cone and prevent bridging. After several minutes of running the grinder mixer, unload the mixture and discard. **Do not feed this mixture to the livestock.**

DETACHING FROM THE TRACTOR



CAUTION: MAKE SURE THE TRACTOR IS SHUT OFF, REMOVE THE KEY AND PLACE THE KEY IN YOUR POCKET.

IMPORTANT: *Make sure the discharge auger and the auger feeder are in their saddles before disconnecting.*

Disconnect the PTO driveline and front shield anchor chain from the tractor and place it on the PTO driveline support bracket (see Figure 16). The PTO driveline support should be tight enough to remain in position when rotated from storage against the frame to use position.

Disconnect the electronic scale power cord, control box power cord, and/or actuator control box power cord from the tractor (if equipped).

Disconnect the hydraulic hoses from the tractor outlets (if equipped with tractor hydraulic functions).

Disconnect 7-Pin connector for lights from tractor and plug into storage receptacle on grinder mixer frame.

Block the tires. Lower the jack stand to the ground. Turn the handle of the jack stand to raise the grinder mixer tongue off of the tractor hitch. Remove the hitch pin and safety chain.

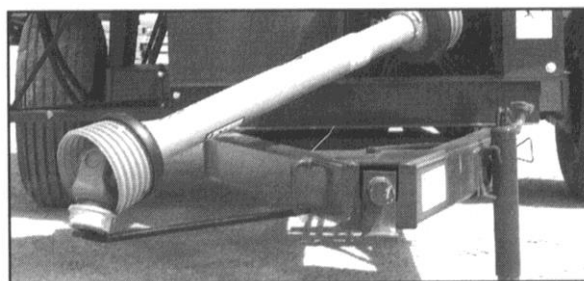

Figure 16 - PTO Support.

OPERATION OF GRINDER MIXER

TRACTOR PTO ENGAGEMENT

The mixer may be operated by engaging the PTO. Always engage the tractor PTO with the tractor engine at idle speed. After the PTO is engaged, increase the engine speed gradually until the advertised operating PTO speed is obtained. Reverse the PTO engagement steps to disengage the PTO.

For smooth PTO operation and to help increase the life of the PTO driveline, make sure the tractor is aligned straight with the frame of the grinder mixer whenever possible.

IMPORTANT: If mixing while in transport, avoid sharp and unnecessary turns which may damage the PTO driveline.

HAMMER MILL CLUTCH PIN



CAUTION: BEFORE CHANGING POSITIONS OF THE CLUTCH PIN, MAKE SURE THE TRACTOR IS SHUT OFF AND PLACE THE KEY IN YOUR POCKET.

The hammer mill clutch pin is located on the front of the fly-wheel (see Figure 17). **Make sure the grinder mixer has come to a complete stop and shut off the tractor before proceeding with the next step.** To engage the hammer mill, turn the fly-wheel by hand to align one of the six slots in the fly-wheel with the pin. Push in the pin and turn 1/4 turn in either direction to lock it in place. To disengage the hammer mill, push in the pin, turn 1/4 turn, and release.



CAUTION: ALWAYS OPERATE PTO AT THE SAME SPEED FOR WHICH THE GRINDER MIXER IS EQUIPPED; 540 OR 1000 RPM. NOTE THE SPEED DECAL ON THE FRONT SHIELD OF GRINDER MIXER.

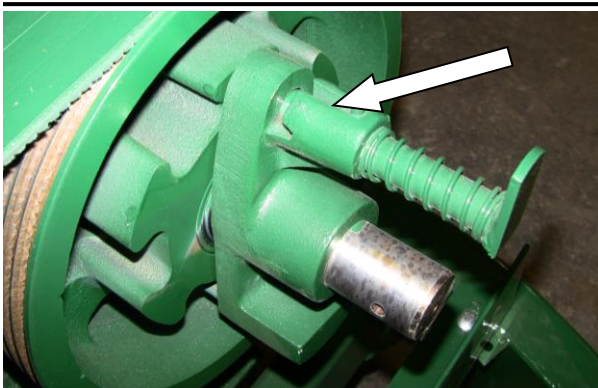

Figure 17 - Hammer mill Clutch Pin (Pin Disengaged in Photo and Shields Removed for Clarity).

FEED GATE

A feed gate is provided in the mill throat with a rubber baffle (removed for roll feed installation) behind it (see Figure 18). The feed gate should be set to the lowest possible position to allow material to flow into the hammer mill evenly.

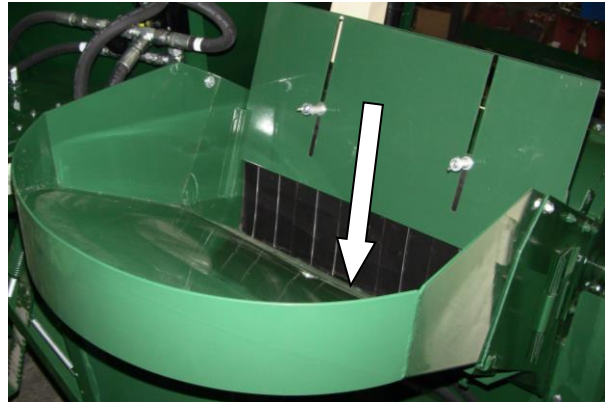

Figure 18 - Feed Gate at Throat of the Hammer mill.

WEAR PLATES



WARNING: HAMMERS MAKE A LOUD BANGING NOISE WHEN CONTACTING THE WEAR PLATES. IMMEDIATELY SHUT THE TRACTOR IGNITION OFF AND DETERMINE THE CAUSE OF THE BANGING BEFORE RESTARTING.

There are two replaceable wear plates in the 6530 hammer mill. The position of the upper wear plate is fixed. The lower wear plate (see Figure 19) is adjustable, but should not need to be moved. Moving the lower wear plate in or out will only change the clearance to the hammers by approximately 1/16" (see Figure 20). Having the lower wear plate should improve the desired particle size of the feed and reduce the horse power required for processing.

Note: The lower wear plate is reversible.

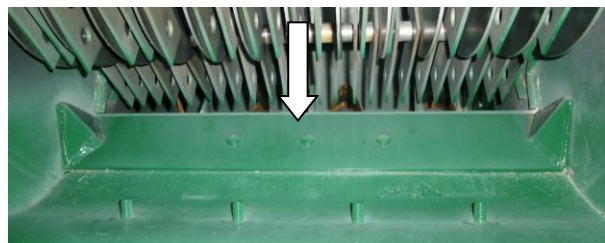

Figure 19 - Lower Wear Plate at Throat of the Hammer mill.

Note: For coarser grind the lower wear plate could be removed completely.



DANGER: TO PREVENT DAMAGE TO HAMMER MILL:

1. KEEP MATERIAL FROM BUILDING UP UNDER WEAR PLATE AND FORCING IT UP INTO HAMMERS BY MAKING SURE THAT THE FRONT EDGE OF LOWER WEAR PLATE IS TIGHT UP AGAINST THE THROAT PLATE.
2. KEEP WEAR PLATE BOLTS TIGHT AND/OR PLACE TACK WELDS ALONG THE FRONT EDGE TO HOLD LOWER WEAR PLATE TIGHT TO THE THROAT PLATE.
3. IF THE LOWER WEAR PLATE IS EVER MOVED OR REPLACED, MAKE SURE THERE IS NO GAP BETWEEN IT AND THE THROAT PLATE. BOLT THE LOWER WEAR PLATE TIGHT OR TACK WELD THE FRONT EDGE DOWN TO THROAT PLATE TO KEEP MATERIAL FROM GETTING BETWEEN THEM.

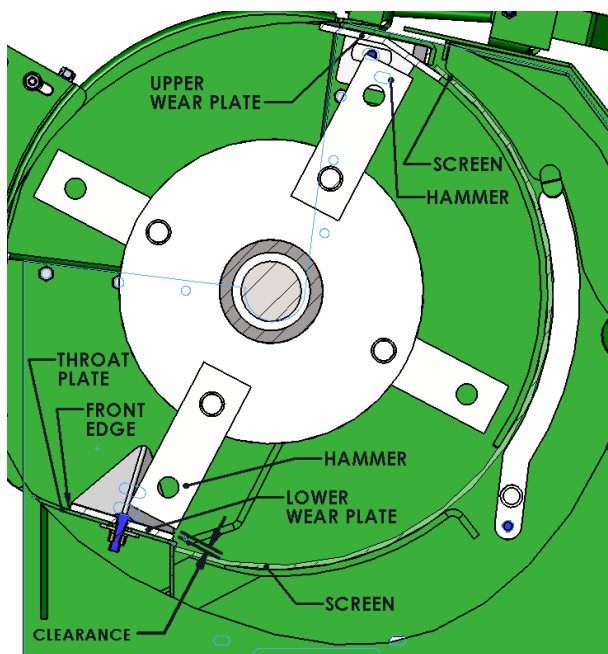

Figure 20 – Wear Plate detail

HAY RETARD BOLTS

The hay retard bolts will help maintain uniform feeding while grinding hay (see Figure 21). The degree of the retard is adjusted by loosening the lock nuts on each of the retard bolts, turning the bolts in (increase) or out (decrease) to the desired position. Secure the bolts by tightening the lock nuts.

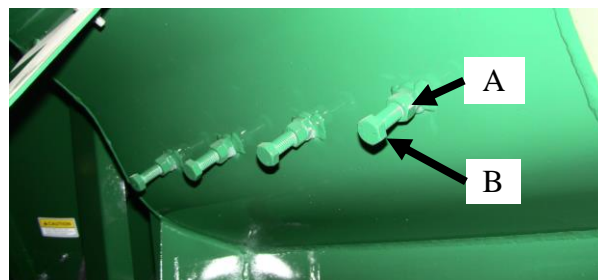

Figure 21 - Hay Retard Bolts (A - Lock Nut; B - Adjustable Retard Bolt, 26 Inch Hammer mill Shown).

HAMMER MILL SCREENS

Hammer mill screens are available in sizes ranging from 1/8 inch up to 2 inch openings. The screen size needed will be determined by the material and degree of fineness desired.

SCREEN CHART

LEGEND

■ = Screen Application

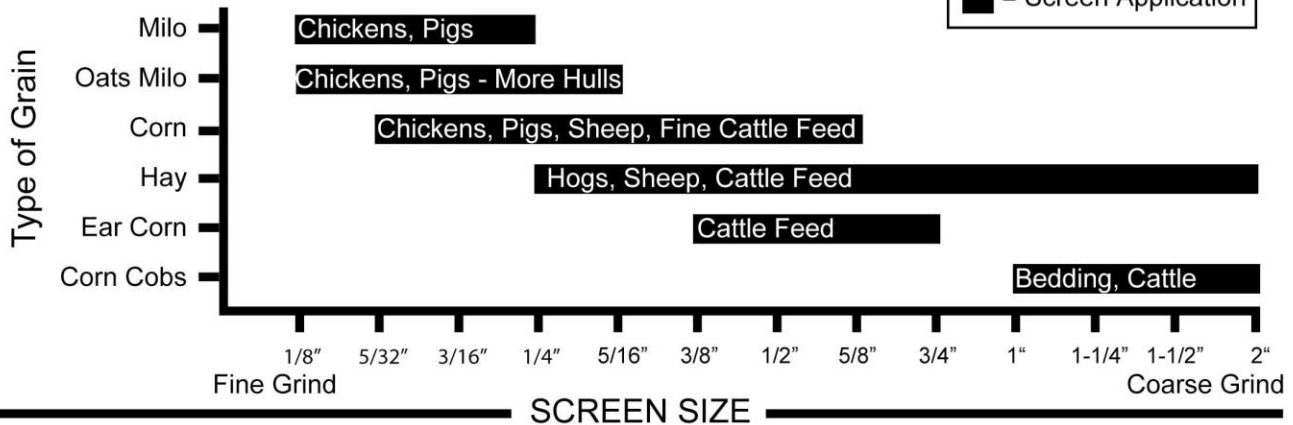

SCREEN SIZE		
1/8"	Finest for the small grains.	
5/32"	Fine, very few hulls.	
3/16"	Fine, more hulls.	
1/4"	largest Screen to be used for small grains leaves some whole. Start grinding corn.	
5/16"	Top end for grinding hog feed. Fine cattle feed.	
3/8"	No whole kernels in ear corn grind.	
1/2"	Will leave some whole kernels.	
5/8"	Nice cob grind, leaves whole kernels.	
3/4"	Nice cob grind, leaves whole kernels.	
1"	Medium bedding, cattle screen for corn cobs.	
1-1/4"	Medium bedding, cattle screen for corn cobs.	
1-1/2"	Recommended for bedding, cattle, uniform grind.	
2"	Recommended for bedding, cattle, uniform grind.	

Table 2 - Screen Chart.

The Table showing the screen sizes may be used as a guide for grinding different types of food (see Table 2).

Do not use a finer screen than needed as this will require more power and reduce mill capacity. Never grind wet corn or hay. This can cause auger problems during loading and unloading

CHANGING SCREENS



CAUTION: DISENGAGE ALL THE DRIVES. SHUT OFF THE TRACTOR ENGINE AND PLACE THE KEY IN YOUR POCKET BEFORE INSTALLING OR CHANGING HAMMERMILL SCREENS. NEVER OPEN THE HAMMERMILL COVER UNTIL THE HAMMERMILL HAS COME TO A COMPLETE STOP.

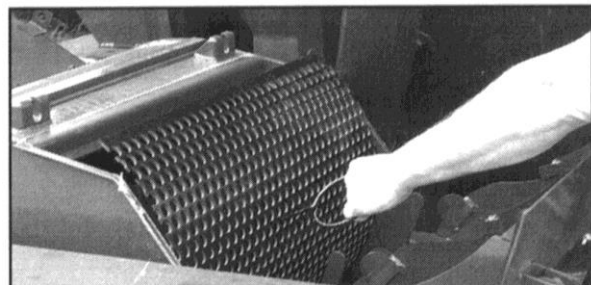

Figure 22 - Changing screens

The screen support rack will drop down to make the screen removal easier. Install the new screen. Close the hammer mill door and then replace the screen hook and locking pins (see Figure 23).

Extra screens are carried in the screen rack located over the left fender.

To install or change the screen, open the hammer mill door and remove the screen with the hook provided (see Figure 22).



Figure 23 - Locking Pin and Latch on Hammer mill Door.

PROCESSING HAY

If hay is to be ground, grind the grain first. Do not grind more than five bales of hay per tank until you are familiar with the results. Large amounts of hay or coarse ground hay can cause *bridging* in the tank and make it difficult to unload. If large quantities of hay are to be ground, run the hay straight through the machine without filling the tank.

Note: *Be careful when running hay through the discharge as it can become tangled in the transition u-joint (see Figure 79). Check u-joint after operation.*

PROCESSING WITHOUT MIXING

To grind any material without mixing, engage the unloading auger lever, open the tank unloading auger door and start the grinding operation.

The feed will be augered into the mixing tank cone and then out through the unloading augers without mixing. Position the unloading auger tube as needed to direct the feed.

ADDING CONCENTRATE OR SUPPLEMENT

Concentrate or supplement should be added to the ground feed through the supplement hopper located at the right rear corner of the grinder mixer (see Figure 24). A serrated sack cutter is located in the hopper opening. A grate is positioned below the sack cutter to keep the bag from falling into the auger.



CAUTION: KEEP HANDS AND FEET CLEAR OF AUGER. MAKE SURE GRATE IS ALWAYS IN PLACE.

Note: *For best results, add the concentrate or supplement before grinding operation. Do not add ingredients to the supplement hopper while grinding, this will over load the auger.*



Figure 24 - Supplement hopper located on center rear right hand side of machine

If micro-ingredients are to be added to the feed, the best results are obtained with a pre-mix, or by adding the supplements and micro-ingredients at the same time. If the micro-ingredients are desired without a pre-mix or other supplement, open the mixing tank lid and add the ingredients directly into the mixer. This should be done at the beginning of the operation. Make sure to close the lid before starting the operation. The supplement hopper lid should always be closed when not in use. If strong additives are not desired in the batch that follows, clean out the tank cone and unloading augers through the clean-out doors (see Figure 25).



CAUTION: MAKE SURE THE PTO IS DISENGAGED AND THE TRACTOR IS SHUT OFF. PLACE THE KEY IN YOUR POCKET BEFORE OPENING OR CLOSING THE CLEAN-OUT DOOR.



Figure 25 - Cleanout Door (A) Located Under Right Hand Side Of Tank Assembly.

Located under the right hand side frame and tank assembly is a hinged door on the bottom of the auger trough. Release two spring clamps and allow door to drop. Keep away from the opening. Run the mixer slowly until the trough and the mixing tank are cleaned out. Keep all bystanders away from the machine.

165 BU. – APPROXIMATE CAPACITY CALIBRATION – IN POUNDS*

Actual weights may vary due to material, moisture, and screen size. Ration weight is not included and is variable.

Window Position	Ground Oats 22.5 lbs/bu	Ground Barley 36 lbs/bu	Ground Milo 56 lbs/bu	Ground Shelled Corn 50 lbs/bu	Ground Ear Corn 38 lbs/bu	Un-ground Shelled Corn 56 lbs/bu
Full	3777	6043	9400	8393	6378	9400
9	3554	5686	8845	7897	6002	8845
8	3302	5282	8217	7337	5576	8217
7	3047	4876	7585	6772	5147	7585
6	2768	4429	6890	6152	4676	6890
5	2528	4044	6291	5617	4269	6291
4	2287	3659	5692	5082	3862	5692
3	1985	3176	4941	4412	3353	4942
2	1744	2791	4342	3877	2947	4342
1	1504	2406	3743	3342	2540	3743

NOTE: * Above weights are approximate and are to be used as a guide only. Variations may occur due to test weight of grain, slope of machine, moisture content, or screen size. For best ration control use an electronic scale.

Table 3 - Approximate Calibration Capacity.

FILLING THE MIXER TANK

Make sure the mixing tank unloading door is closed. As the mixing tank is filling, watch the ground feed through the mixing tank windows. If the top window is covered, this does not mean the tank is full as the mixing auger throws material away from the center of the tank. Continue loading until the top window clears (feed drops) and then becomes covered again about half-way (see Figure 26). Stop feeding material into the processor at this point, but continue operating until the processor has had time to clear. *Do not overload the mixer.* An overload can cause damage to the machine. To estimate the number of bushels that are in the tank, refer to Table 3.

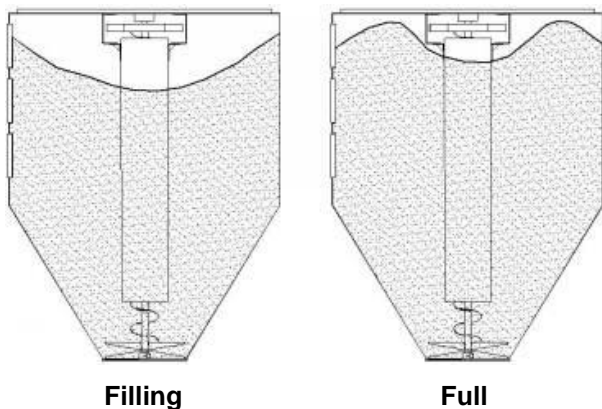

Figure 26 - Filling pattern

For the best mixing results, always add lightweight bulky materials first. Always add high moisture corn or grain last. Excessive amounts of wet or bulky material may cause *bridging* in the mixing tank.

SPRING LOADED TANK LID



CAUTION: DISENGAGE ALL THE DRIVES. SHUT OFF THE TRACTOR ENGINE AND PLACE THE KEY IN YOUR POCKET BEFORE OPENING THE MIXING TANK LID.

If the mixing tank is accidentally overfilled, it is equipped with a spring loaded tank lid (see Figure 27). The lid also allows access to the inside of the mixing tank. Keep the lid closed and latched at all times.



CAUTION: IF ENTERING THE TANK, MAKE SURE THE TRACTOR ENGINE IS SHUT OFF. PLACE THE KEY IN YOUR POCKET AND DISCONNECT THE PTO DRIVELINE.



Figure 27 - Spring Loaded Tank Lid.

After the processing is completed and the desired ration is in the mixing tank, allow the mixer to operate until it is ready to unload. Run the mixer 2 to 3 minutes to ensure the feed and supplements have been thoroughly mixed.

IMPORTANT: Avoid sharp and unnecessary turns which may damage the PTO driveline during transport.

DISCHARGE AUGER POSITIONING

After mixing, the finished feed may be unloaded into storage bins, wagons, or feeders. Positioning (lift and swing) and drive of the unloading auger is controlled hydraulically.



Figure 28 - Unloading Auger Positioning (shown in upper 60° to -11° configuration).

TRACTOR HYDRAULIC LIFT AND SWING

Connect six hydraulic hoses (eight if equipped with an Auger Feeder and not using the Selector Valve (see Figure 29)) with the appropriate male connectors to the tractor (hoses are marked with different colored zip ties to help with identification). Make sure the proper hoses are connected to the same tractor hydraulic circuit. Activate the appropriate tractor valve to lift the Discharge Auger, and then use the other hydraulic valve to swing the Discharge Auger to the desired position.

Hose Color Markings:

Discharge Auger Pressure	Blue (2X)
Discharge Auger Return	Blue (1X)
Discharge Cylinder Raise	Red (2X)
Discharge Cylinder Lower	Red (1X)
Discharge Swing Left	Yellow (2X)
Discharge Swing Right	Yellow (1X)

TRACTOR HYDRAULIC SELECTOR VALVE

Hydraulic lift and swing is accomplished by using the tractor's hydraulic system valves. If a hydraulic Auger Feeder (and/or Roll Feeder) is present, a

double selector valve (see Figure 29) is required to direct flow of the hydraulic fluid. The Discharge Auger or the Auger Feeder (and/or Roll Feeder) may either be operated independently, but not at the same time. Position the selector valve control "IN" to direct fluid to the Discharge Auger or "OUT" for the Auger Feeder (and/or Roll Feeder).

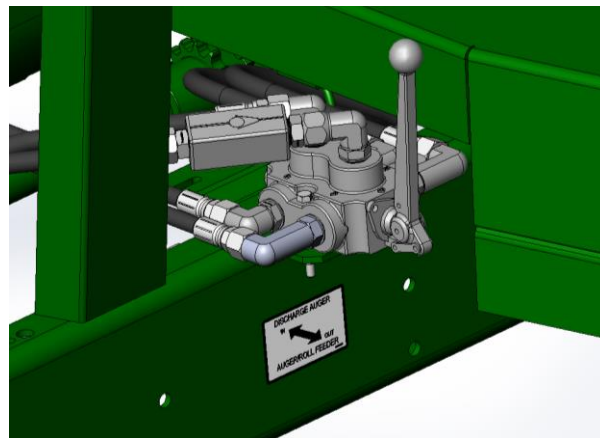

Figure 29 – Tractor Hydraulics Selector Valve (Lever Shown in the 'IN' Position – Discharge Auger).

TRACTOR HYDRAULIC DISCHARGE AUGER LIFT AND SWING ADJUSTMENT

Turning the flow control valves adjustment knobs changes the speed at which the lift cylinder raises or lowers the Discharge Auger and the rate at which the Discharge Auger swings left and right. See Figure 30 for which Flow Control Valve adjusts each function. Turning the knob clockwise restricts flow and slows the function. Conversely turning the knob counter-clockwise increases flow and speeds up the function.

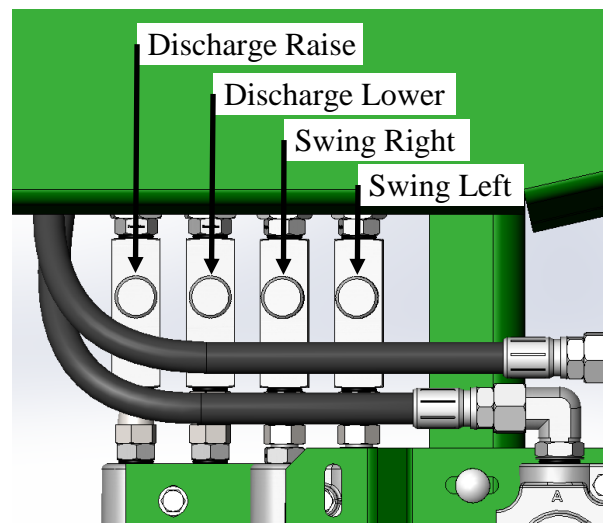

Figure 30 – Tractor Hydraulics Flow Control Valves (shown with Selector Valve).

DISCHARGE GATE FUNCTION

When the discharge auger is in position to unload the tank the gate can be open or closed by an electric actuator (see Figure 31). The actuator is controlled by either a Control Box (Tractor Hydraulics (see Figure 32)) or the Complete Control Box System (see Figure 99) with Remote Control (Self-Contained Hydraulics (see Figure 101)).

IMPORTANT: Be careful with finer ground feed as it can stall out the Discharge Auger if the gate is open to far.



Figure 31 - Discharge Gate with Electric Actuator in closed position.

TRACTOR HYDRAULIC ACTUATOR CONTROL

Mount the Actuator Control Box (see Figure 32) in the tractor cab in a convenient location with the supplied parts. Connect the power as shown in Figure 33. Flipping the toggle switch up opens the gate and moving the switch down closes the gate.

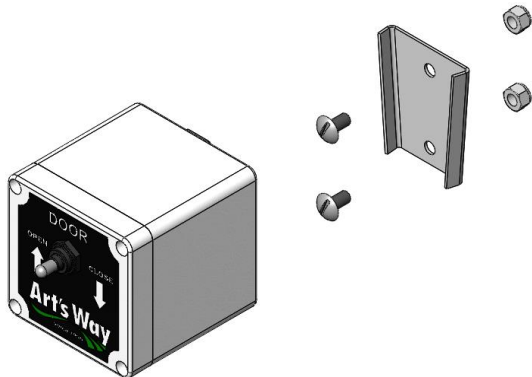

Figure 32 – Tractor Hydraulics Actuator Control Box and mounting parts.

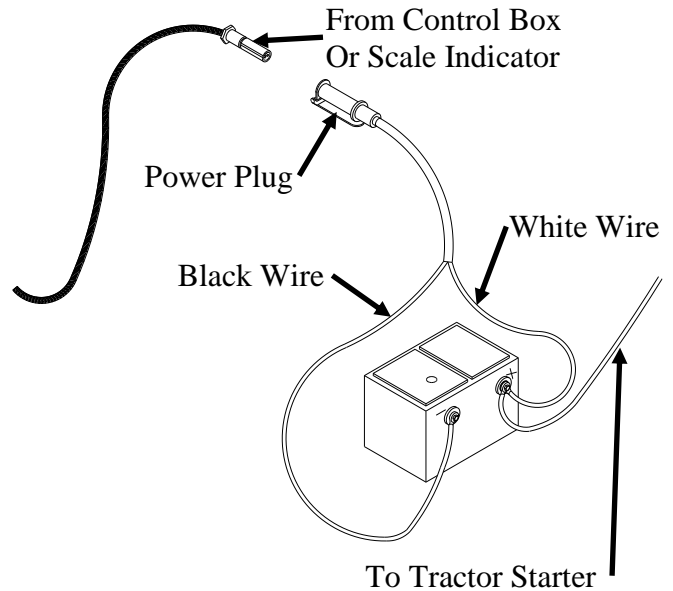

Figure 33 - 12-Volt System power wire hookup to battery.

ROLL FEED

The optional Roll Feeder operates in a similar fashion to the Auger Feeder. See HYDRAULIC ROLL FEED portion of the ATTACHMENTS section.

FOLDING AUGER EXTENSION

Optional extensions for the unloading auger include a 3 to 6 feet folding or bolt-on extension (see Figure 34). For discharge heights of the optional extensions (see Figure 35 and Table 4).

If the grinder mixer is equipped with a folding auger extension, make sure the outer auger drive cog is properly engaged and the extension tube is locked before engaging the Discharge Auger Drive.

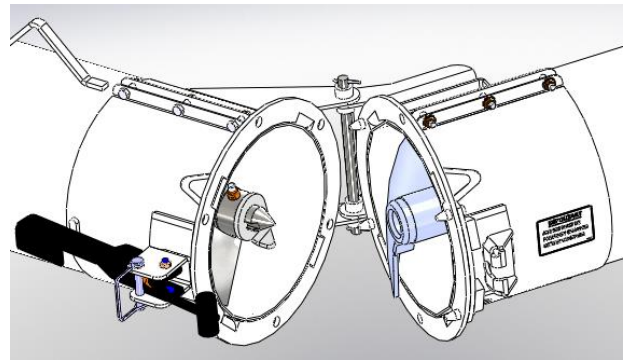

Figure 34 - Folding Auger Extension.

Unloading Auger Configuration	Tube & Elbow Combined Length (10 ft. /12 ft.)	Discharge at 46° High Angle Vertical Height (10 ft. /12 ft.)	Discharge at 60° High Angle Vertical Height (10 ft. /12 ft.)
Standard 10 ft. or 12 ft. Long Discharge Tube – No Extensions	11 ft. 5 in./13 ft. 5 in.	16 ft. 10 in./18 ft. 3 in.	18 ft. 6 in./ 20 ft. 3 in.
3 ft. Auger Extension	14 ft. 5 in./ 16 ft. 5 in.	19 ft. 0 in./ 20 ft. 5 in.	21 ft. 1 in./ 22 ft. 10 in.
6 ft. Auger Extension	17 ft. 5 in./ 19 ft. 5 in.	21 ft. 2 in./ 22 ft. 7 in.	23 ft. 8 in./ 25 ft. 5 in.

Table 4 - Unloading Auger Heights.

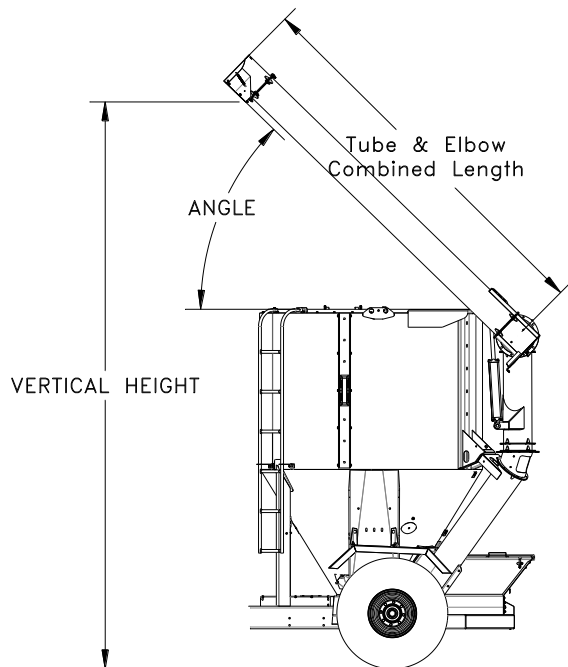

Figure 35 - Unloading Auger Heights (Refer to Table 4 for Detailed Heights.)

UNLOADING AUGER HOOD

When the unloading auger tube becomes overloaded, a spring loaded door opens on the end to prevent damage to the drive (see Figure 36).



Figure 36 - Unloading Auger Hood.

AUGER FEED OPERATION

NOTE: The grinder mixer may be equipped with a hydraulic auger feeder.



Figure 37 – Auger Feeder Latch Handle (shown in locked position).

To position the Auger Feeder, pull Latch Handle (see Figure 37) toward you and turn to right to Unlock Auger Feeder and lift the bottom of the auger feeder slightly so the latch can clear the fender mount. Swing the auger feeder outward, away from the tank to ensure it will clear the fender when it is lowered. Lift the auger feeder slightly and pull the rope on the right hand side to disengage the height adjustment ratchet bar. Raise or lower to the desired height and release the rope. Remove the clip pin holding the auger feeder folding hopper up and then swing the hopper down (see Figure 38).

To place Auger Feeder back in transport position do the reverse of above, and be sure to lock the Auger Feeder down by pulling the Latch Handle (see Figure 37) toward you and turn to left until it is secured in one of the four Locking positions.



Figure 38 - Auger Feeder Operation.

When processing material such as ear corn, the grate must be left in the up position. If you must grind with the grate up, use extreme care and make sure to stay clear of the auger.



DANGER: TO PREVENT PERSONAL INJURY:

1. USE THE GRATE OVER THE AUGER WHENEVER POSSIBLE
2. KEEP HANDS AND FEET OUT OF THE HOPPER AREA AND DO NOT CLIMB ON OR OVER THE HOPPER AT ANY TIME.
3. KEEP CHILDREN AND BYSTANDERS AWAY FROM THE MACHINE WHILE THE MACHINE IS IN OPERATION

Make sure the auger feeder emergency shutoff handle (see Figure 43) will stop the auger feeder. Loosen the cable clamps to re-adjust if it does not.

The auger feeder swing brake prevents the auger from swinging. Tighten or loosen as desired (see Figure 39).

NOTE: If a more accurate reading is desired and the machine is equipped with an electronic scale, **DO NOT** allow the auger feeder to rest on the ground. Place it in the desired position and set the swing brake (see Figure 39).



Figure 39 - Auger Feeder Swing Brake.

The auger feeder is counter balanced by a spring (see Figure 40). If the spring needs adjusted; loosen the nut on the lower bolt, turn the bolt in to increase the spring tension, tighten the nut.

AUGER FEED POSITIONER

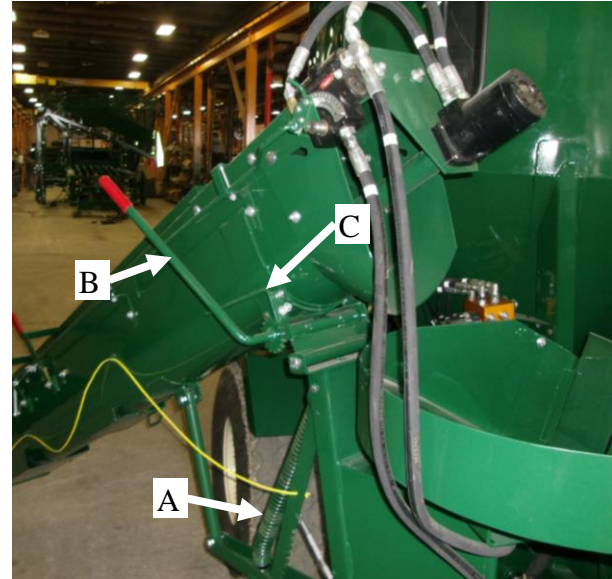

Figure 40 - Auger Feeder Positioner And Spring Adjustment (A - Spring; B - Positioner Long Handle; C - Positioner Short Locking Handle).

The auger feeder is equipped with a unique patented feature called a positioner (see Figure 40). This positioner allows the hopper to be re-positioned approximately 6 inches (see Figure 41) in or out (if the Transport Locking Plate is removed, see Figure 42) without having to move the tractor. To operate the positioner; hold the positioner long handle securely, release the short handle, re-position the auger feeder hopper under a spout or against a building, and then release the handles.

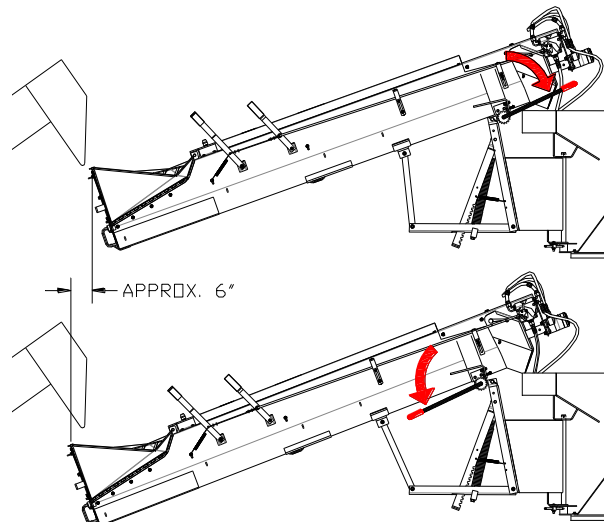

Figure 41 - Auger Feeder Positioner operation.

AUGER FEED POSITIONER LOCKING PLATE

Figure 42 - Transport Locking Plate.

IMPORTANT: The auger feeder is shipped with a transport locking plate (see Figure 42.) that locks the positioner (see Figure 40) in one position. If the positioner is to be used, this plate needs to be removed. But if the positioner is not needed, this plate can be kept in place to keep positioner from moving during transport of the grinder mixer.

AUGER FEED CONTROLS

Shut-Off handles are provided at the auger feeder hopper and at the flow control valve at the top of the auger feeder housing. To shut off the auger feeder, pull the handle at the hopper area or move the flow control valve to off (see Figures 43 and 44).

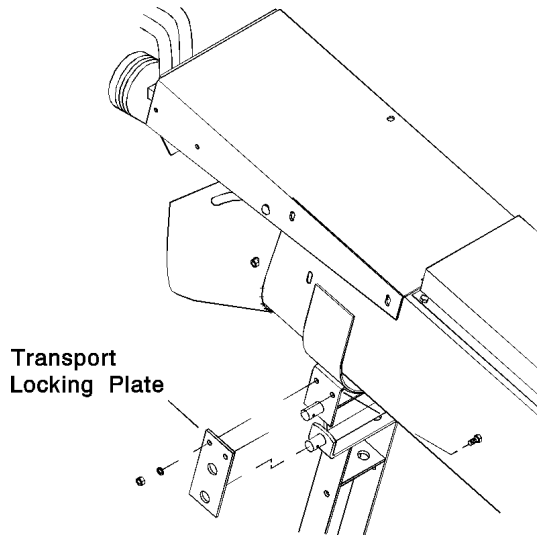
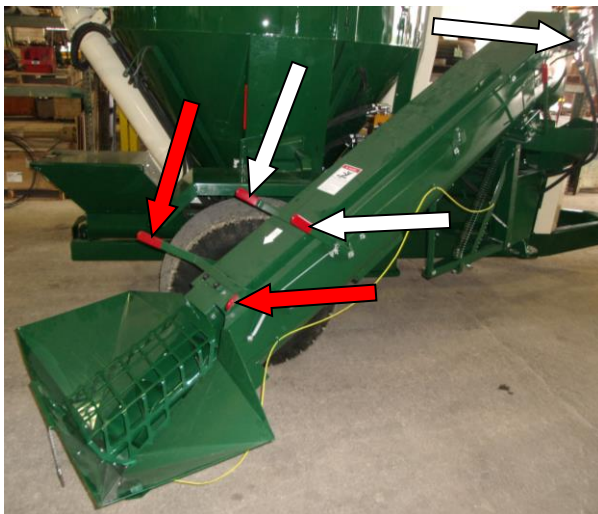

Figure 43 - Hydraulic Auger Feeder controls (shown in off position): Throttle controls (white arrows) and Emergency Shutoff (red arrows).



Figure 44 - Hydraulic Auger Feeder Control - shown in full on position (See Arrow).

To start the auger feeder, the flow control handle is moved forward (clockwise, see Figure 44) or the handles (see Figure 43) located near the hopper until the desired speed is reached. If the hydraulic auger feeder is operated by tractor hydraulics, there must be a minimum of 8 GPM flow and 1500 psi pressure available.

TRACTOR HYDRAULIC AUGER FEED CONTROLS

For the Tractor Hydraulic Auger Feeder a selector valve will be located to the left rear side of the processor. The handle on this valve must be "OUT" to divert the oil to the Auger Feeder. If the handle for the Selector Valve is "IN", oil flows to the Discharge Auger. (see Figure 45.)

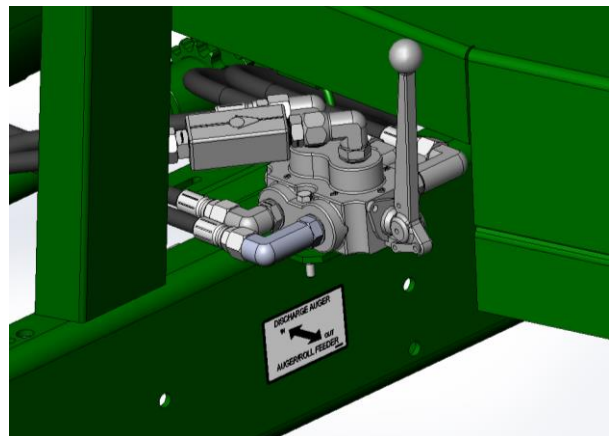

Figure 45 - Hydraulic Auger Feeder Selector Valve Lever is in the IN Position – Discharge Auger).

GRINDER MIXER ADJUSTMENTS



DRIVE CHAIN ADJUSTMENTS

The mill to mixer auger/supplement hopper drive chain and the discharge auger drive chain are tensioned with an idler sprocket (see Figure 46). Adjust the chain tension by positioning the idler sprocket.

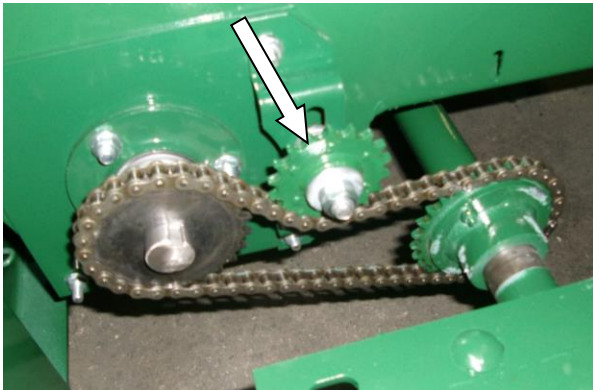

Figure 46 - Mill To Mixer Auger Drive Chain.

MAIN DRIVE CHAIN

Adjust the tension of the main drive chain by doing the following steps (see Figure 47). Make sure the chain deflection is 1/2 inch total at the longest span.

- Loosen locking nut "A" (see Figure 47). Adjust nut "B" on j-bolt "C" to compress spring "D" increasing the tension of roller "E" on chain.
- Adjust bolt "A" (Figure 47) until the proper chain deflection is achieved.
- Retighten locking nut "A".

NOTE: The chain should be checked and oiled daily.

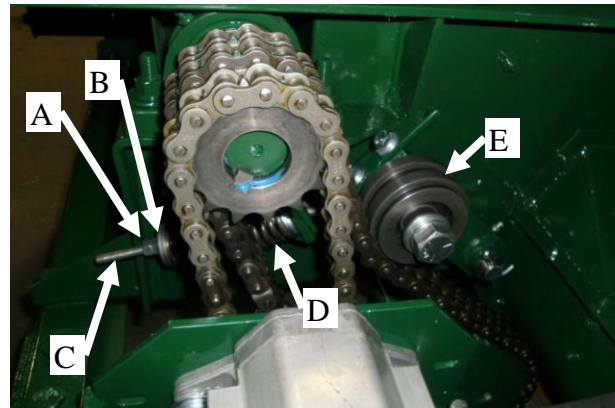

Figure 47 - Drive Chain Adjustment (Shield Removed for Clarity).

MAIN DRIVE BELTS

Belts on new machines have been properly tensioned at the factory. To re-tension the belts on a machine which has been in operation, do the steps that follow:

- Loosen locking nut "A" (see Figure 48).
- Adjust nut "B" on bolt "C" to compress spring "D" increasing the tension of roller "E" on belt.
- Place a scale at the midway point of the double V-belts on the pulleys.
- Adjust bolt "A" (Figure 48, Detail A) until 15 pounds of pull on the scale raises the top of one double V-belt approximately 1/4 inch above the top of the remaining belts (see Figure 50).
- All six pairs of belts should have the average of 1/4 inch deflection at 15 pounds.
- Retighten locking nut "A".

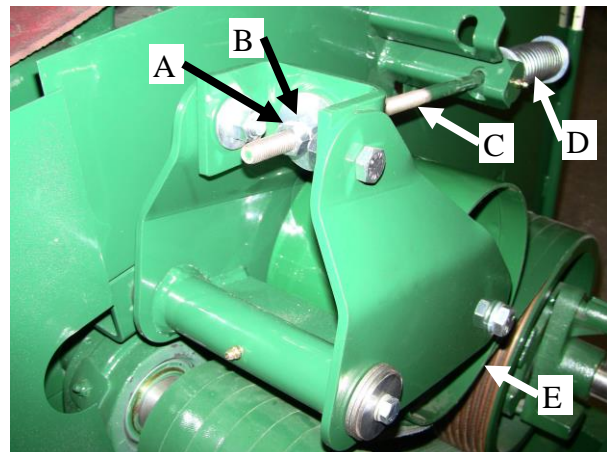

Figure 48 - Belt Tension Adjustment Idler - 1000 RPM Drive Shown (Shields Removed for Clarity).

If the proper tension cannot be attained in the procedure above, the position of the Front Jack Shaft Bearing will need to be adjusted. Loosen the tension on the belt from the idler as above. Then do the following (see Figure 49):

- Loosen bolts "B" and locking nut "C".
- Adjust bolt "A" to tighten the belt making sure that the jack shaft stays parallel to hammer mill.
- Retighten locking nut "C" and bolts "B"
- Re-tension belts with Idler as above (see **Adjustments - Main Drive Belts**).

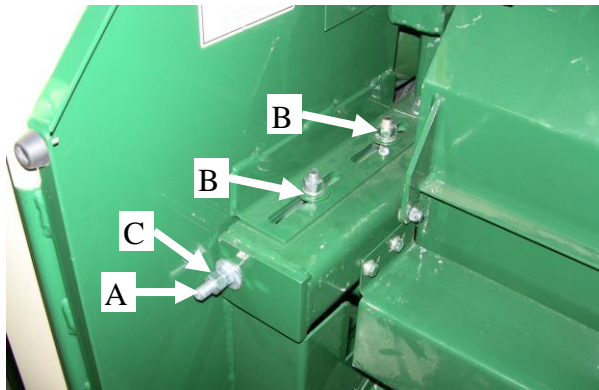

Figure 49 - Belt Tension Adjustment Bearing Mount.

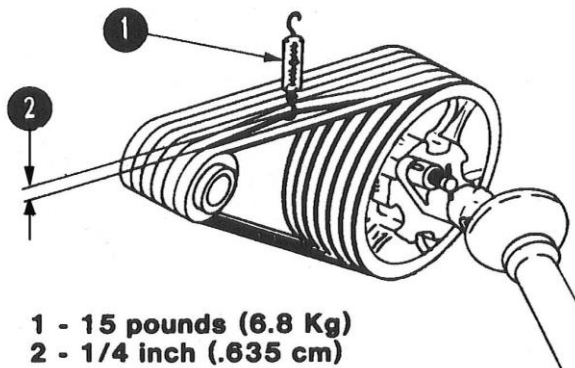

Figure 50 - Checking Belt Tension.

IMPORTANT: Proper alignment of the pulleys must be maintained when adjusting belt tension.

Belts should be checked periodically for proper tension and alignment, especially when the machine is new or when a new set of belts are installed (see Figure 51). During operation, if the drive belts are very hot or are smoking due to being loose, do not shut off the machine, but stop grinding and allow the mill to continue to run for several minutes until the belts have cooled. After the belts have cooled, stop the machine to re-tension the belts.

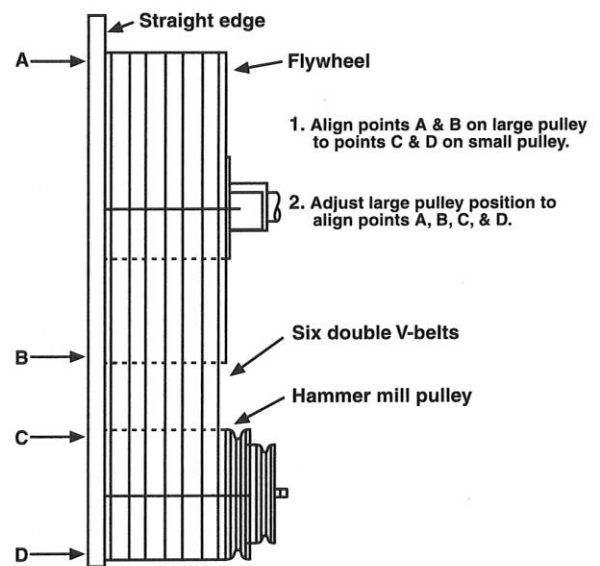

Figure 51 - Belt Pulley Alignment.

HAMMER MILL DOOR

To increase the hammer mill door pressure on the screen, adjust the length of the T-handle threaded end. Check the adjustment and tighten the locking nuts in place against the pivot block (see Figure 52).

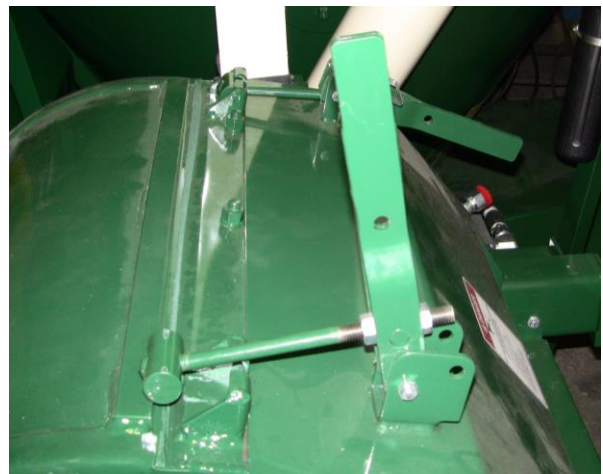

Figure 52 – Hammer mill Door Pressure.

HYDRAULIC SWING ADJUSTMENT

If any problem is encountered with the hydraulic swing adjustment drive, adjust and/or check as follows (see Figure 53):

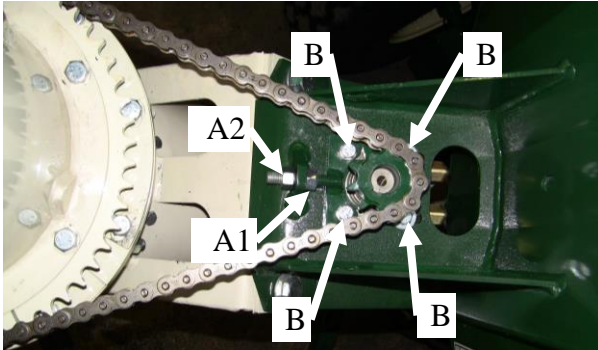

Figure 53 - Hydraulic Swing Adjustment (Shields Removed For Clarity).

1. Loosen the two tension nuts "A1" & "A2", and the four hydraulic motor bolts "B", and then remove the #60 chain.
2. Wrap the #60 chain completely around the 58 tooth sprocket. Inspect the chain, matching the sprocket teeth in the two areas where the sprocket is split. If the rollers on the chain do not seat into the root of the sprocket teeth, loosen the 6-bolts that hold the sprocket to the upper ring; holding the chain across the split areas, re-tighten the bolts so the chain properly seats into the sprocket teeth.
3. Tighten tension nut "A1" to set the proper tension on chain. Re-tighten the hydraulic motor bolts "B", and then check the alignment of the sprocket. If the sprocket is not aligned properly, loosen the set screws on the 10 tooth sprocket and re-align. Tighten tension nut "A2" to lock hydraulic motor in place.

SWIVEL STOP

An unloading auger swivel stop prevents the unloading auger from contacting the mixing tank when moved from the storage position (see Figure 54). Relocate the swivel stop so it makes contact with the bracket before the unloading auger contacts the tank.



Figure 54 - Hydraulic Swing Adjustment (Shields Removed For Clarity).

SWIVEL STOP ADJUSTMENT

Loosen the bolts holding the Lower Stop (see Figure 55). (Do not loosen the bolts for Upper Stop, it is fixed.) Adjust the Lower Stop so it makes contact with the Upper Stop when the Discharge Auger is in the Saddle.

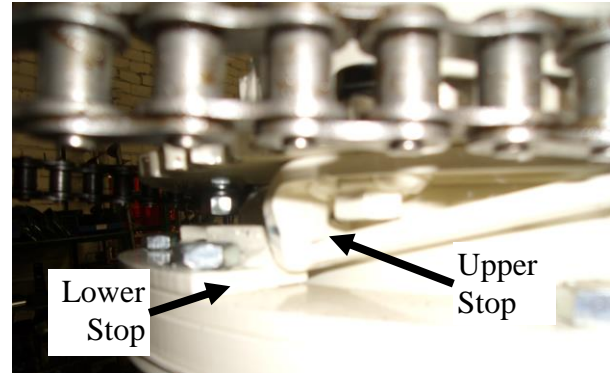

Figure 55 - Swivel Stop (Shield Removed For Clarity).

DISCHARGE AUGER DRIVE ADJUSTMENT

There is an upper and lower location for the Discharge Auger Drive chains (see Figure 56).



Figure 56 – Discharge Auger Drive Chain Locations (see arrows).

If chain drive "A" (see Figure 57) for the Discharge Auger Drive becomes loose. Loosen the Hydraulic Motor bolts "B" holding the Hydraulic Motor. Then loosen nuts "C". Screw in bolts "D" equally until chain is tight. Retighten nuts to lock bolts in place. Retighten Hydraulic Motor bolts "B".

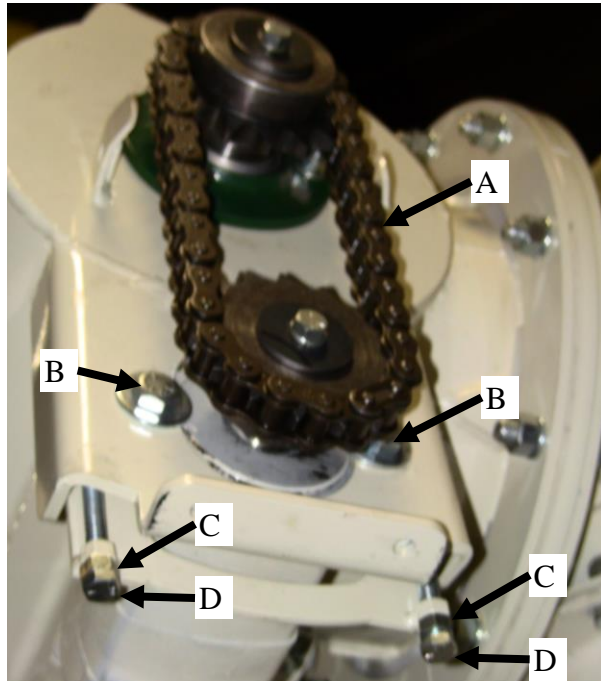

Figure 57 – Discharge Auger Drive Chain (Shield Removed For Clarity).

DISCHARGE AUGER HEIGHT SETTINGS

There is an upper 60° max. to -11° min. configuration (for unloading into high storage bins) and lower 46° max. to -27° min. configuration (for lower storage bins and feed troughs) for the Discharge Auger elevations.

NOTE: The 6530 is shipped from the factory in the upper configuration (see Figure 58).

If Discharge Auger needs to be changed to the lower configuration do the following steps (see Figures 58 & 59):

1. Rest Discharge Auger in Saddle.
2. Unpin Cylinder Clevis from Lug.
3. Unbolt Lug and Support Mount.
4. Move Support Mount to upper position.
5. Bolt parts back together as shown in Figure 58.
6. Reattach Cylinder Clevis with Pin.
7. Discharge is ready for operation.

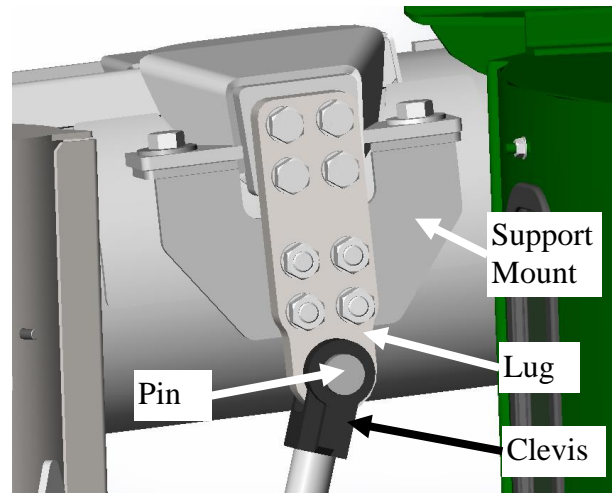

Figure 58– Upper Discharge Auger Configuration.

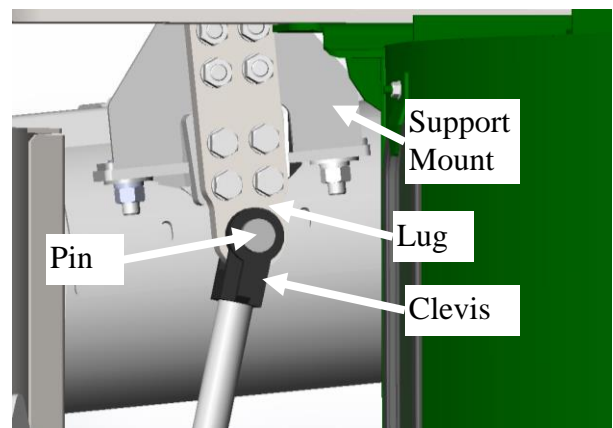

Figure 59 – Lower Discharge Auger Configuration.

OPEN AND CLOSED CENTER TRACTOR HYDRAULICS

As the standard, this machine is equipped for tractor “Open Center” hydraulic operation. If the operation of the Auger Feeder or Roll Feeder is to be with a tractor that is equipped with a “Closed Center” hydraulic system, a revision to the plumbing at the Flow Control Valve bypass should be made. *Refer to the tractor operator’s manual or consult your local tractor dealer to make sure which system the tractor is equipped with.*

To convert to “Closed Center” hydraulic system, revise by removing the Tee that goes into the Flow Control Valve and replace it with a Plug (SAE -10 ORB) in the Flow Control Valve and connecting the two hose together with a Union (SAE -8 JIC) fitting (see Figure 60 & 61).

If the system has two control valves for the Auger Feeder and Roll Feeder, change only the Roll Feeder Flow Control Valve.

IMPORTANT: *When hydraulics are revised for “Closed Center” operation, do not use on a tractor with “Open Center” hydraulics.*

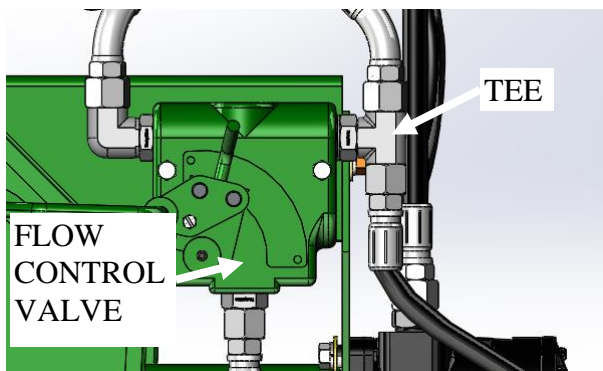

Figure 60 – Open Center Hydraulic System.

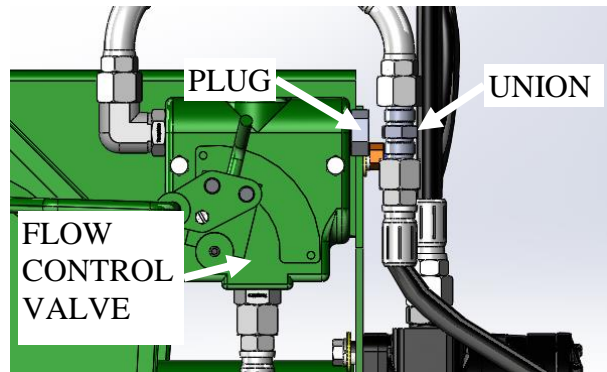

Figure 61 – Closed Center Hydraulic System.

WHEEL BEARINGS

Raise the frame and make sure it is blocked securely so the wheels may turn freely (make sure the opposite wheel is also blocked securely). To tighten the wheel bearing, remove the hub cap. Remove the cotter pin from the slotted nut and tighten the slotted nut while rotating the wheel. Loosen or back-off the nut to the nearest slot, insert and spread the cotter pin.

There should be a slight drag on the bearing following the adjustment. Replace the hub cap (see Figure 62).



Figure 62 - Wheel Bearing Adjustment.

LUBRICATION



CAUTION: BEFORE LUBRICATING THE MACHINE, MAKE SURE THE ENGINE IS SHUT OFF, PLACE THE KEY IN YOUR POCKET AND DISCONNECT THE IMPLEMENT INPUT DRIVELINE

The grinder mixer is designed to require a minimum amount of lubrication. The points that are to be lubricated should be serviced regularly at the specified intervals listed in this manual.

Keep your supply of lubricating oil and grease in clean containers and covered to protect them from dust and dirt.

Keep the lubricating gun nozzle clean and free from dirt at all times. Wipe all of the dirt from the grease fittings before lubricating them.

PTO DRIVELINE

Grease PTO sliding shafts every 20 hours. Zerk is located on the outer shaft and is accessible through cutout slots in spin shields (see Figure 63).



Figure 63 - PTO Driveline Shaft (See Arrow).

Grease the bearing crosses and plastic shaft bearings every 20 hours. The bearing cross zerk can be accessed through round hole in PTO spin shield (see Figure 64).

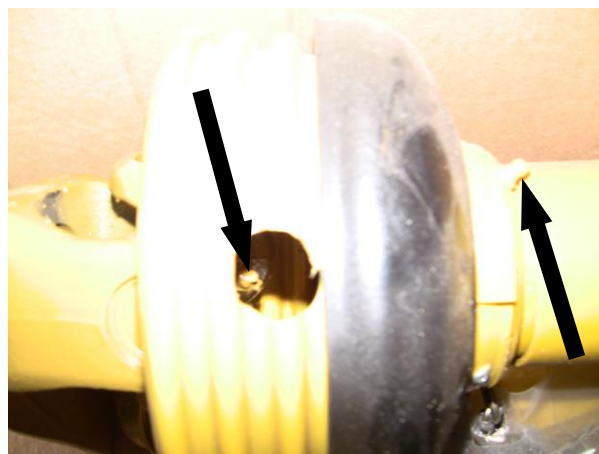

Figure 64 – PTO Driveline Cross Bearing (Left Arrow) and Plastic Shaft Bearings (Right Arrow).

HAMMERMILL SHAFT BEARINGS

Grease the front and rear pillow block bearings (See Figure 65 and Figure 66) on the hammermill cylinder shaft:

Light Use (1-14 loads/week):

1 pump every 30-40 hours of use or once a month.

Heavy Use (15-up loads/week):

1 pump every 20-30 hours of use or twice a month.

Grease with SAE Multi-Purpose type grease (NLGI 2 Grade Rating with minimum viscosity of 500 SUS at 100°F). (High Speed/Temp also acceptable)

IMPORTANT: Over greasing of the Hammermill Cylinder Shaft Bearings can cause pre-mature failures.

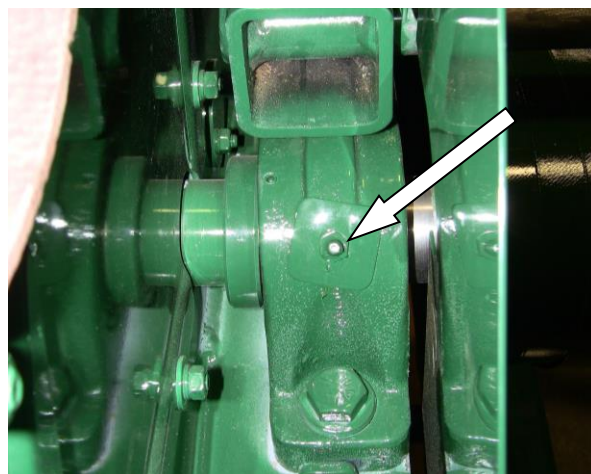

Figure 65 – Front Cylinder Shaft Bearing (See Arrow) (Shields Removed For Clarity).

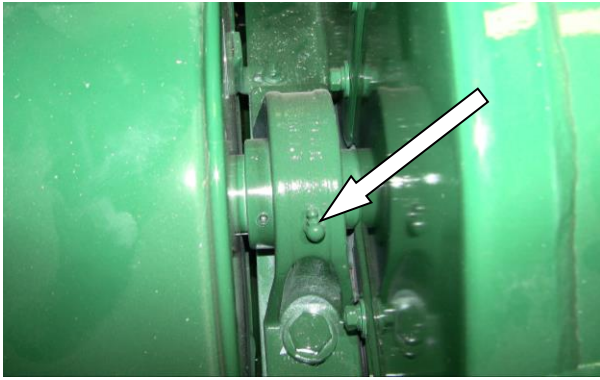

Figure 66 – Rear Cylinder Shaft Bearing (See Arrow) (Shields Removed For Clarity).

DRIVE BELT IDLER TENSIONER

Grease the pivot shaft and rod guide periodically (see Figure 67, arrows).

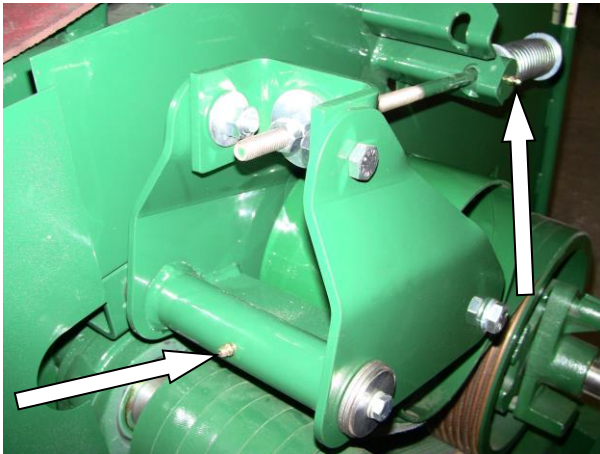

Figure 67 – Drive Belt Idler Tensioner (Shield Open for Clarity).

HAMMER MILL ENGAGING PIN

Periodically oil the sliding pin that engages the large hammer mill drive pulley. Use light engine oil for lubrication (see Figure 68).

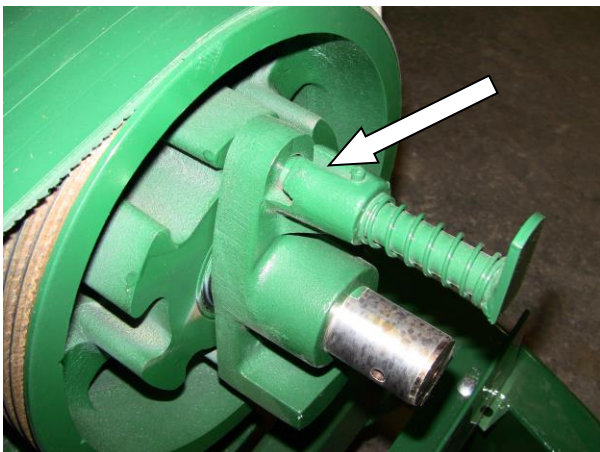

Figure 68 – Hammer mill engaging pin (shields removed for clarity).

DRIVE SHAFT BEARINGS

Grease the pillow block bearings on the front and rear bearings on the hammer mill jack shaft (see Figure 69 & 70). Grease pillow block bearings on the lower line shaft once a month or every 25 hours of operation (see Figure 71 & 72). Use SAE multi-purpose type grease for these lubrications.

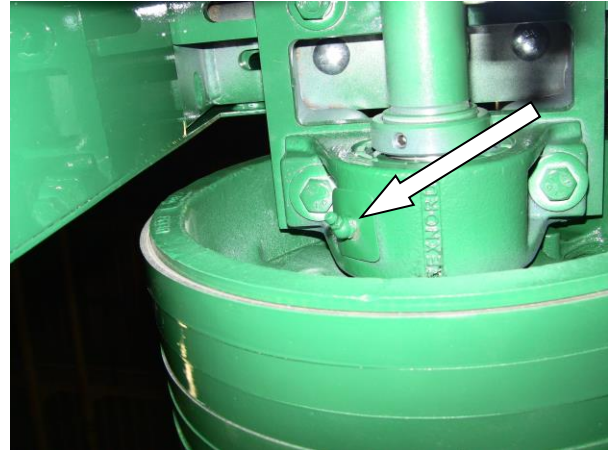

Figure 69 - Jack Shaft Front Bearing, Front (Looking Up Under Machine)

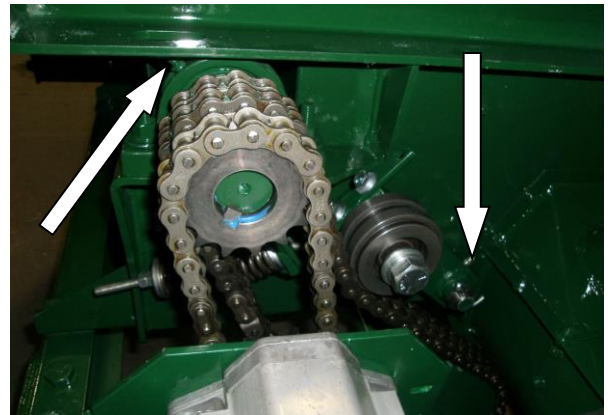

Figure 70 - Jack Shaft Front Bearing, Rear (Accessed through 1"x2" slotted hole) and Idler Arm Pivot (Shield Removed For Clarity).

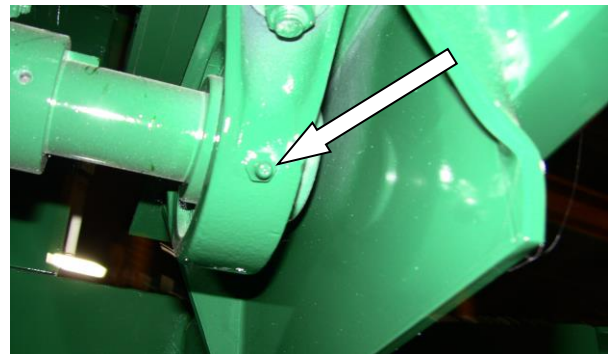

Figure 71 - Mixer Drive Shaft Bearing, Front.

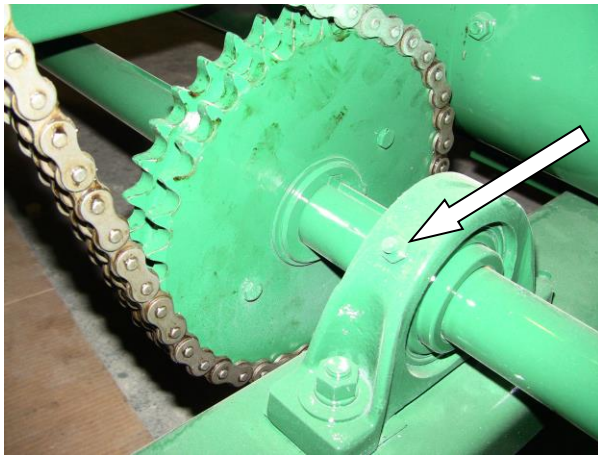

Figure 72 - Mixer Drive Shaft Bearing, Rear (Shield Removed For Clarity).

CHAINS

Chains should be lubricated at frequent intervals. Apply light engine oil to the chain. Oil the chain on the inside located in the upper side of lower the strand (see Figure 73).

The chains should also be cleaned regularly. Remove the chains and dip or soak them in kerosene. Once the chains have been cleaned, dry and oil them thoroughly.

**Oil Roller Chain on
Upper Side of
Lower Strand**

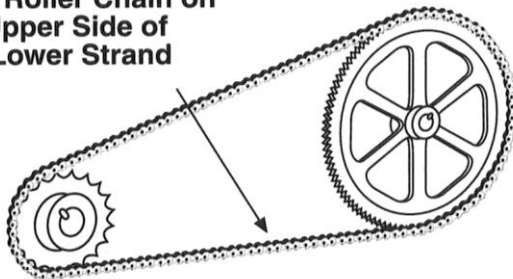

Figure 73 - Oiling Roller Chains.

The split end of the chain clip must face the direction opposite of the chain travel. Make sure the clip is properly seated in the groove on the ends of the pin (see Figure 74).

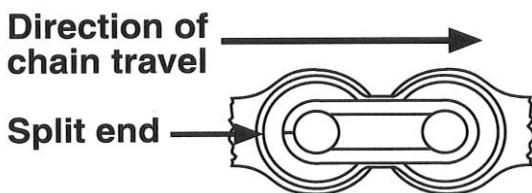

Figure 74 - Chain Spring Clip.

GEARBOX

Make sure to check the oil level of the gearbox at the base of the mixing tank every 24 hours of operation by removing the check plug on the side of the gearbox. Add SAE 90 weight gear oil if necessary and until oil runs out of the check hole (see Figure 75). Change the oil after the first 50 hours of operation. Routine oil change intervals will vary depending on the severity of the environment. Normal changes should occur between 250 and 1000 hours of operation. The longest life at continuous service will be realized when the oil temperature does not exceed 200° F.

IMPORTANT: Do not overfill.

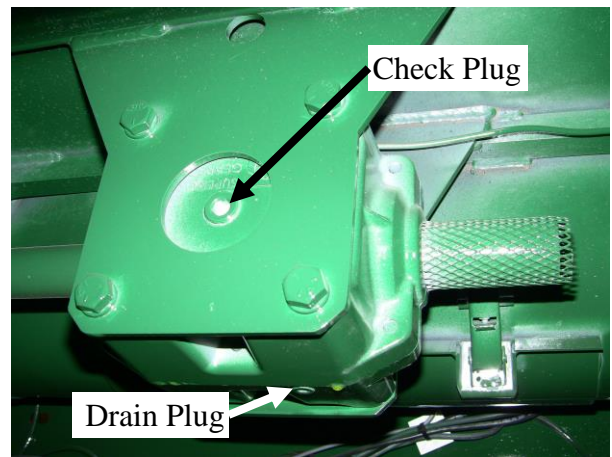

Figure 75 - Gearbox Lubrication.

Grease upper gearbox bearing weekly or every 10 hours of operation with SAE multi-purpose type grease, through remote grease zerk located on rear base housing of mixer (see Figure 76).

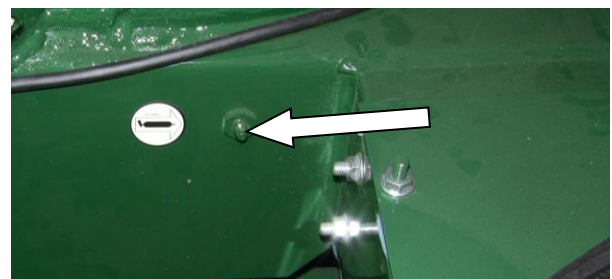

Figure 76 - Gearbox Lubrication Upper Bearing Remote location (next to Supplement Hopper).

LOWER VERTICAL MIXING AUGER

Refill the grease seal at the bottom of the vertical mixing auger every six months with SAE multi-purpose type grease. Access to this fitting can be gained through the clean-out door in the mixing tank cone, below the large bottom flight of the mixing auger (see Figure 77).

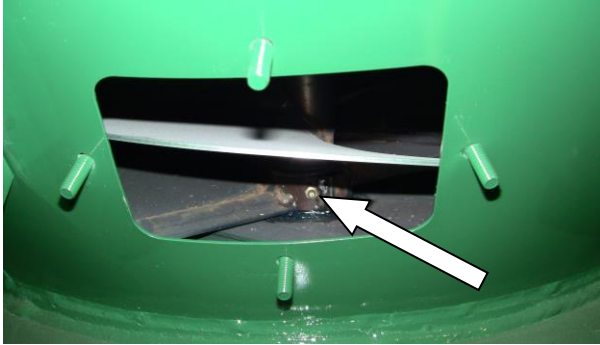

Figure 77 - Clean-Out Door in Mixing Tank Cone And Grease Zerk For Seal At Bottom Of Vertical Mixing Auger (Door Removed for Clarity).

UPPER VERTICAL MIXING AUGER

Grease the upper vertical mixing auger bearing weekly or every 10 hours of operation with SAE multi-purpose type grease. Access to this bearing can be gained through the top of the mixing tank (see Figure 78).

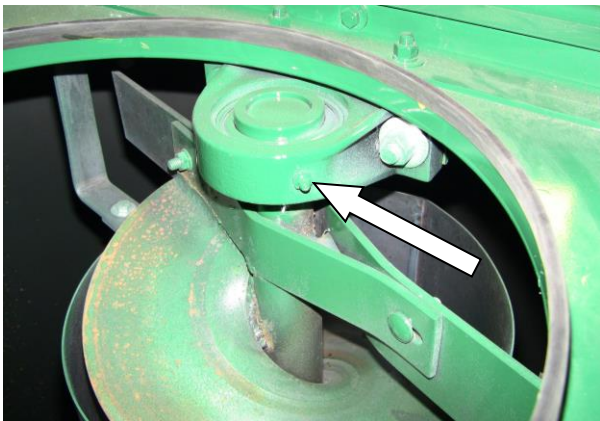

Figure 78 – Upper Vertical Mixing Auger Bearing (Door Open for Clarity).

DISCHARGE U-JOINT

Grease the Discharge U-Joint weekly or every 10 hours of operation with SAE multi-purpose type grease. Access to this u-joint can be gained through the transition door (see Figure 79). There are two lube points on u-joint. **Note there is a third zerk in one of the yokes that is just a spare.**

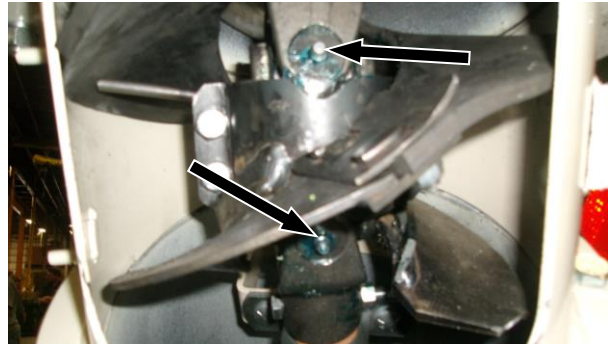

Figure 79 – Discharge U-Joint (Door Open for Clarity).

DISCHARGE PIVOT PIN

Lubricate the Discharge Pivot Pin periodically with light machine oil (see Figure 80).

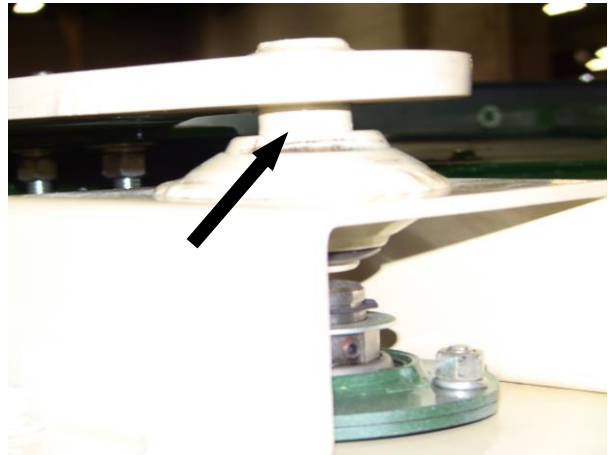

Figure 80 – Discharge Pivot Pin.

WHEELS

Remove, clean, and repack the wheel bearings once a year or every 100 hours of operation using SAE multi-purpose type grease (See Figure 81).



Figure 81 - Wheel Bearing Lubrication.

SERVICE

TORQUE SPECIFICATIONS



CAUTION: DISENGAGE ALL DRIVES AND MAKE SURE THE TRACTOR ENGINE IS SHUT OFF. PLACE THE KEY IN YOUR POCKET AND DISCONNECT THE PTO DRIVELINE PRIOR TO SERVICING THE GRINDER MIXER.

When performing service on the grinder mixer and its components, take time to use and comply with the torque specification guide. (Refer to Table 5.)

Size	Clamp Load	Plain GR 5	Plated GR 5
1/4 – 20 (.250)	2,025	8 ft. lbs.	76 in. lbs.
5/16 – 18 (.3125)	3,338	17 ft. lbs.	13 ft. lbs.
3/8 – 16 (.375)	4,950	31 ft. lbs.	23 ft. lbs.
7/16 – 14 (.4375)	6,788	50 ft. lbs.	37 ft. lbs.
1/2 – 13 (.500)	9,075	76 ft. lbs.	57 ft. lbs.
9/16 – 12 (.5625)	11,625	109 ft. lbs.	82 ft. lbs.
5/8 – 11 (.625)	14,400	150 ft. lbs.	112 ft. lbs.
3/4 - 10 (.750)	21,300	266 ft. lbs.	200 ft. lbs.
7/8 – 9 (.875)	29,475	430 ft. lbs.	322 ft. lbs.
1 – 8 (1.00)	38,625	644 ft. lbs.	483 ft. lbs.
1-1/8 – 7 (1.125)	42,375	794 ft. lbs.	596 ft. lbs.

Table 5 - Torque Specification Guide for Grade 5 Bolts.

SHEAR BOLTS



WARNING: SHEAR BOLTS MAKE A LOUD NOISE WHEN SHEARED. IMMEDIATELY SHUT THE TRACTOR IGNITION OFF AND DETERMINE THE CAUSE OF SHEARING.

Shear bolts will make a loud noise when they shear. This is your warning to turn off the tractor ignition immediately and determine the cause of the shear.

When replacing sheared bolts, always tighten them securely using lock nuts. The shear bolts must be the correct hardness to ensure safety (see Figure 82). **Warning: using a harder bolt in a shear bolt location can cause damage to vital and more expensive drive components.**

IDENTIFICATION OF SAE BOLT GRADES; HEAD MAKINGS

Grades 0, 1, and 2 no markings



Grades 5: 3 radial dashes 120° apart



Grades 8: 6 radial dashes 60° apart



Figure 82 - SAE Bolt Identification.

SPROCKET AND CHAIN ALIGNMENT

Make sure the sprockets are in line with the shafts (see Figure 83 & 84). If the sprockets are not aligned a sideways pull will develop and will concentrate the load on sides of the sprocket teeth and on the side of the chain (See Figure 85). This faulty alignment will result on excessive wear on both the chain and sprockets.



Figure 83 - Mixer Sprocket (Shields Removed For Clarity).

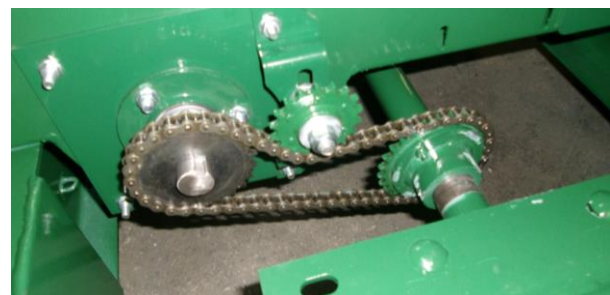

Figure 84 – Mill To Mixer Sprocket (Shields Removed For Clarity).

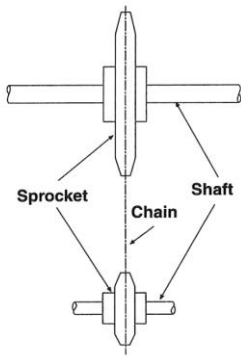

Figure 85 - Sprocket Alignment.

Adjust mounting of main drive bearings (see Figures 71 & 72) so that the sprocket on the mixing auger shaft and sprocket on the gearbox are running on center. Tighten bearing bolts. Run grinder mixer slowly and observe the mixing auger shaft. If shaft is in need of further adjustment to better align sprockets; for position of the sprockets (see Figure 86). Excessive wear of chain and sprockets will result if sprockets are not centered properly.

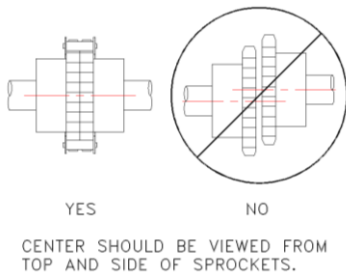

Figure 86- Gearbox Coupler Sprocket Alignment.

REPLACEMENT OF WORN OR DAMAGED HAMMERS

Hammers must be replaced in pairs to maintain proper balance. This is accomplished by replacing the hammers opposite of each other (180 degrees apart) using a matched pair.

REVERSING THE HAMMERS



CAUTION: MAKE SURE THE HAMMER-MILL HAS STOPPED ROTATING BEFORE THE HAMMER MILL DOOR IS OPENED. SHUT THE TRACTOR IGNITION OFF AND PLACE THE KEY IN YOUR POCKET. SAFELY DISENGAGE ALL DRIVES.

There are four rows of hammers in the rotor assembly with a total of 96 hammers on a 26 inch hammer mill (see Figure 87 and 88). The hammers are reversible, but make sure to always replace the hammers and spacers in the exact sequence in which they were removed. This will preserve the balance of these specially matched units. All four corners can be used on each hammer.

STANDARD SPACING FOR 96 HAMMERS

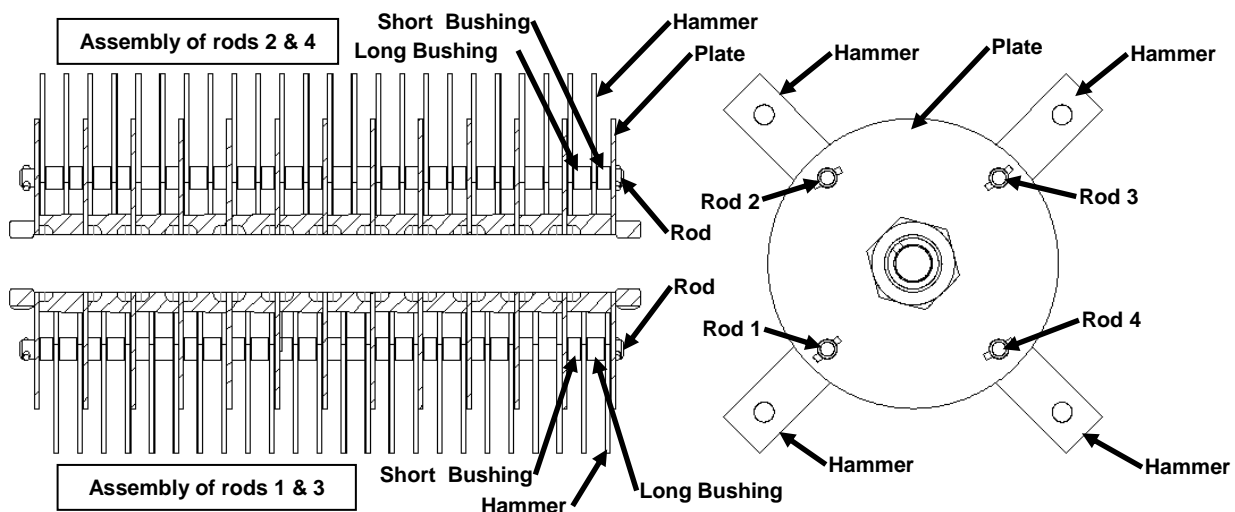

Figure 87 - Proper Hammer Spacing for 96 Hammers (26 Inch Hammer mill).

ALTERNATE SPACING FOR 96 HAMMERS

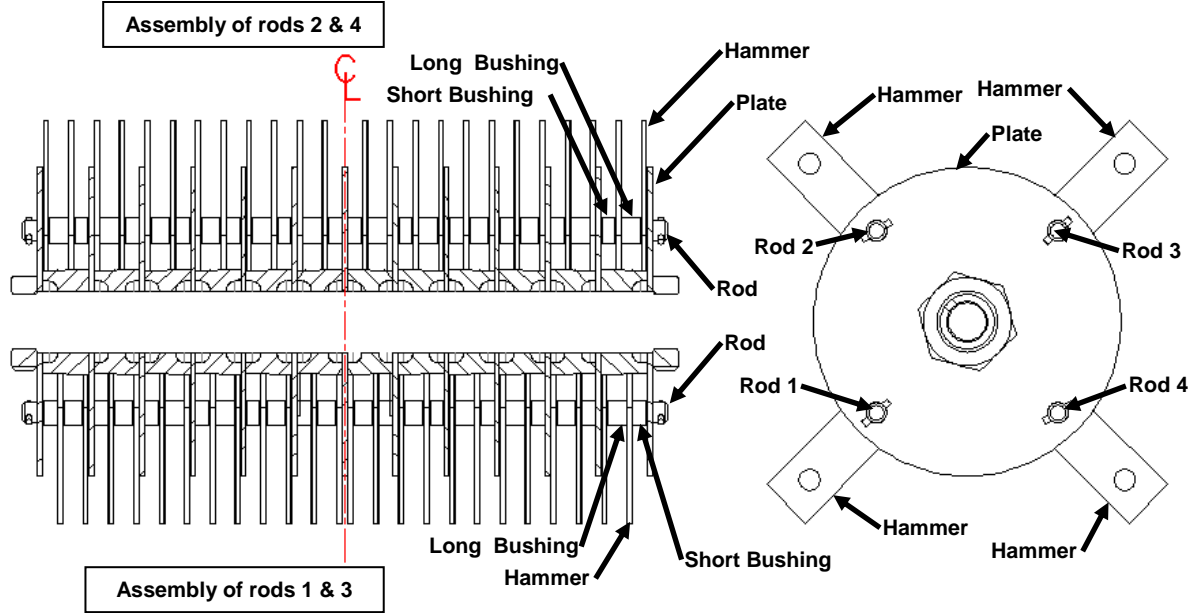

Figure 88 – Alternate Hammer Spacing for 96 Hammers (26 Inch Hammer mill).

To remove the hammers, remove the bolts from the side of the mill and round plate (see Figure 89 and Figure 90). Release the tension on belt idler roller to allow access to removal hole (Figure 91). Remove the pins from each end of the rod and pull the rods outward making sure the hammers are put back in the same place from which they were removed.



Figure 89 - Hammer Removal Inside Hammer mill, Hole to Remove Hammer mill Rods (Shields Removed For Clarity).

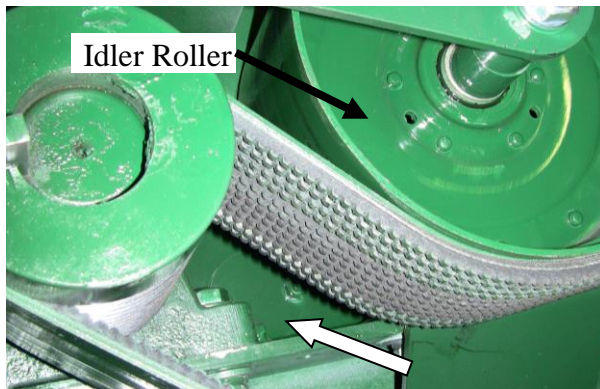

Figure 90 – Hammer mill Removal Hole, Plate To Be Removed (Shields Removed For Clarity).

MAIN DRIVE BELT REPLACEMENT

To remove the drive belts, relieve tension applied to drive belts by idler roller. Loosen nuts that control spring tension (see Figure 91). If belts still cannot be removed loosen the bolts holding bearing (see Figure 92, Detail B). Then relieve the belt tension by loosening the bolt (see Figure 92, Detail A) and move bearing mount and sheave.

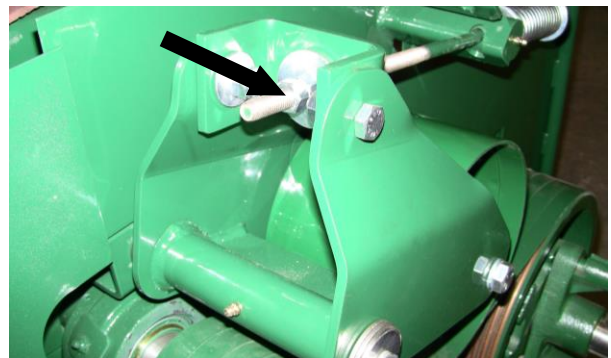

Figure 91 – Belt Replacement - Idler Roller (Shields Removed For Clarity).

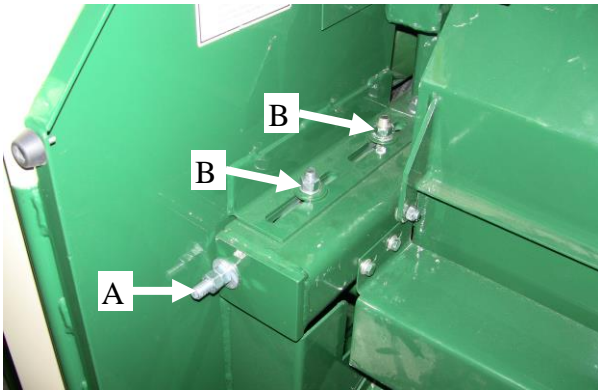

Figure 92 - Belt Replacement – Drive Sheave and Bearing Mount.

After the belts are no longer in tension, remove the belts and replace them with the new set and continue as described in **GRINDER MIXER ADJUSTMENTS - Main Drive Belts**. Make sure to realign the pulley and the sheave.

WEAR PLATE REPLACEMENT



WARNING: HAMMERS MAKE A LOUD BANGING NOISE WHEN CONTACTING THE WEAR PLATES. IMMEDIATELY SHUT THE TRACTOR IGNITION OFF AND DETERMINE THE CAUSE OF BANGING.

There are two replaceable wear plates in the 6530 Hammer Mill (see Figure 93 & 94).

Upper Wear Plate: Unscrew the 4-bolts (2 on each side) that hold it in place, then remove the hood and slide the wear plate out toward the throat of the hammer mill.

To replace the wear plate, slide it in making sure that it is fully seated. Check dimensions shown (+/- 1/16"). If not fully seating then remove it and clear any obstructing material. Make sure the hammers do not hit the wear plate before operating the hammer mill.

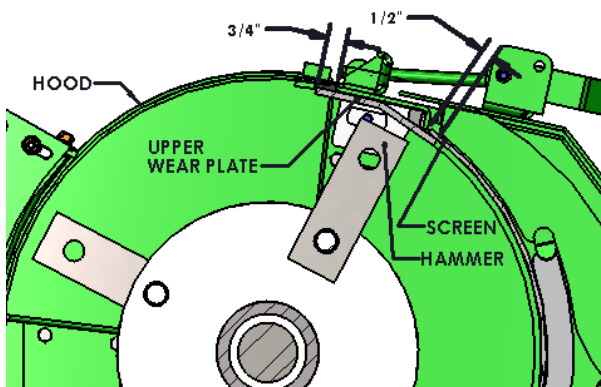

Figure 93 – Upper Wear Plate Detail

Note: The lower wear plate is reversible.



DANGER: TO PREVENT DAMAGE TO HAMMER MILL:

- 1. KEEP MATERIAL FROM BUILDING UP UNDER WEAR PLATE AND FORCING IT UP INTO HAMMERS BY MAKING SURE THAT THE FRONT EDGE OF LOWER WEAR PLATE IS TIGHT UP AGAINST THE THROAT PLATE,**
- 2. KEEP WEAR PLATE BOLTS TIGHT AND/OR PLACE TACK WELDS ALONG THE FRONT EDGE TO HOLD LOWER WEAR PLATE TIGHT TO THE THROAT PLATE.**
- 3. IF THE LOWER WEAR PLATE IS EVER MOVED OR REPLACED, MAKE SURE THERE IS NO GAP BETWEEN IT AND THE THROAT PLATE. BOLT THE LOWER WEAR PLATE TIGHT OR TACK WELD THE FRONT EDGE DOWN TO THROAT PLATE TO KEEP MATERIAL FROM GETTING BETWEEN THEM.**

Lower Wear Plate: Unscrew the bolts (2-each on side and 3-each center of wear plate or 3-welds along front edge) holding the lower wear plate in place and/or grind any welds holding the front edge down to the throat plate (see Figure 94).

To replace the wear plate, slide it in making sure that it is fully seated. It must be tight against the throat plate with no gap along the front edge for material to get between. Clean any material out that could cause problems. Make sure that the hammers do not hit the wear plate (there should be a minimum of 1/32" clearance). Moving the lower wear plate in or out will only change the clearance to the hammers by approximately 1/16" (see Figure 94). Weld front edge down or bolt center down so there is no gap with throat plate. Make sure the hammers do not hit the wear plate before operating the hammer mill.

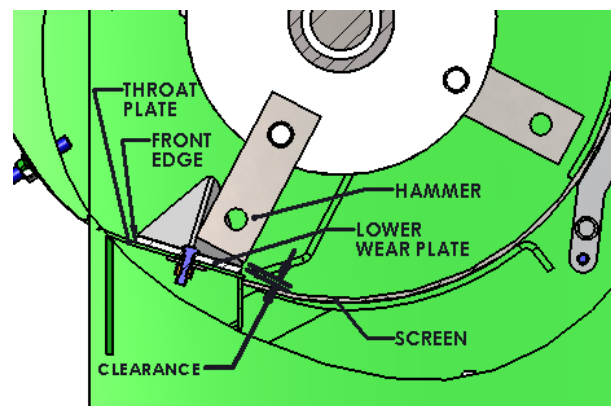

Figure 94 – Lower Wear Plate Detail

TROUBLESHOOTING GUIDE

The majority of difficulties are caused by improper adjustments. When you encounter trouble, perform a systematic check of all possible adjustments using the chart that follows. If difficulties cannot be corrected by making the adjustments that follow, consult your local Art's Way authorized dealer for further assistance.

TROUBLE	POSSIBLE CAUSE	POSSIBLE REMEDY
PTO driveline is hard to telescope and hard to connect	Shafts are twisted due to overloading of the mill	Replace PTO driveline if necessary, load uniformly, and adjust belts to prevent slipping (1000 rpm recommended over 100 hp)
	Lack of grease on the sliding halves	Lubricate as necessary
Mill vibrates excessively while in operation	PTO driveline is not properly aligned	Front of grinder main shield must be parallel to tractor axle
	PTO driveline is bent	Replace the PTO driveline
	Missing and/or broken hammers	Replace the hammers (in pairs)
	Tractor drawbar is not adjusted properly	Adjust the tractor drawbar (Refer to Figure 12.)
Excessive noise when turning the mixer while it is in operation	Turning the mixer too sharply	Avoid sharp turns
Low volume from hammer mill	Hammer mill is not operating at optimum speed	Before grinding, set tractor throttle to rated PTO speed (540 or 1000 rpm)
	Hammer mill screens and/or hammers are worn	Reverse and/or replace the screens and hammers if necessary
	Hammer mill is not level	Find level surface if at all possible
	Mill drive belts are slipping	Adjust the drive belts (Refer to Figures 48-50)
Tractor engine RPM falls below the rated PTO speed while grinding	Adding too much feed to the mixer	Reduce flow of material to the mill
	Screen size is too small	Increase the screen size
	Feed gate is too high	Lower the feed gate
	Drive belts are too loose	Adjust the drive belts (Refer to Figures 48-50)
Drive belt squeals when the mill is engaged	Drive belts are too loose	Tighten the drive belts
Drive belts show excessive wear	Belts are out of alignment	Align the pulleys
	Belts are slipping	Adjust the drive belts (Refer to Figures 48-50)
Material bridges in the tank	High moisture content ear corn or too much hay is being ground	Grind high moisture ear corn last or run straight through tank
		Use a smaller screen or add more grain with hay
Feed roll will not draw hay slice into the mill	Feed roll is too low	Raise the feed roll
		Adjust the hay retard bolts

TROUBLE	POSSIBLE CAUSE	POSSIBLE REMEDY
Mill will run but the mixing auger does not run	Bolt(s) sheared in the drive	Repair the cause of the bolt(s) shearing and replace bolt(s)
Discharge auger running, but the feed is not unloading	Mixer tank gate is closed	Open the mixer tank gate
	Gate actuator is not working	See next
Gate actuator is not working	Fuse is blown in control box	Replace fuse
	Wire disconnected to actuator	Reconnect or repair wires
	No power to control box	Reconnect to tractor power supply
	Actuator is bad	Replace actuator
Discharge auger will not engage	Discharge auger drive chain(s) broken or slipping	Replace and/or retighten chain(s)
	Selector valve is not positioned correctly	Change the position of the selector valve (in for Discharge Auger)
	Discharge auger drive hydraulic motor(s) not working	Check hydraulic system
Discharge auger slows down or stalls	Feed overloading discharge auger	Lower gate to reduce feed flow to rate discharge auger can handle
	Reduced hydraulic fluid flow to motors	Increase hydraulic fluid flow (GPM) to motors
Discharge auger jerks when it is raised or lowered	Excessive hydraulic flow rate to lift cylinder	Adjust the flow rate with the Flow Control Valves
	Air in hydraulic line or cylinder	Run grinder mixer at low rpm 5-10 minutes. During this time, activate discharge lift cylinder to ensure that air is removed from system
	UHMW washers in joint worn or damaged	Replace UHMW washers in joint
Discharge auger raises and lowers too slowly	Incorrect hydraulic flow rate to the lift cylinder	Adjust the flow rate with the Flow Control Valves
	Air in hydraulic lines	Run grinder mixer at low rpm 5-10 minutes. During this time, activate discharge lift cylinder to ensure that air is removed from system
Auger feeder stops when the mill is engaged	Hydraulic flow control valve is disengaged	Engage the flow control valve
	Selector valve is not positioned correctly	Change the position of the selector valve (out for auger feeder)

NOTE: SELF-CONTAINED TROUBLE SHOOTING STARTS ON PAGE 52.

SELF-CONTAINED: INTRODUCTION

This section of the manual has been prepared to acquaint you with the proper operation, adjustment, lubrication, and service of the 6530 with self-contained hydraulics. Take time to read and understand both this manual and efficient operation of your portable unit. The best insurance from an accident is a careful and knowledgeable operator.

Note: Some pictorials used show guards and shields removed for easy identification. Be sure that all shields and guards are in place before operating. These are for your protection.

The self-contained hydraulic system features a hydraulically driven discharge positioning lift and swing, and an auger feeder with or without roll feed. Also available are electric linear actuator used to operate the discharge door. All controls, except for the auger feeder control valve, are within easy access to the operator by remote control. The remote control system consists of two

components: the ergonomically designed macro-remote control device and the equipment mounted control box and receiver module.

This system can be used with any tractor that can maintain a rated PTO speed when grinding. There is no hydraulic connection between the mixer and the tractor, the must also provide a minimum of 12-15 volts DC and 10 amperes to operate the electrical activated flow control valve and linear actuator.



WARNING: BECAUSE THE OPERATOR IS ALLOWED TO OPERATE THE SYSTEM WITHOUT LEAVING THE TRACTOR, SPECIAL CARE IS NEEDED TO AVOID INJURY OR DAMAGE. WHEN LOCATING THE DISCHARGE TUBE INTO POSITION, STAY CLEAR OF OVERHEAD POWER LINES, FARM BUILDINGS AND ANYONE IN THE AREA.

SELF-CONTAINED: PREPARING FOR OPERATION

Prepare the grinder mixer and tractor as instructed in the grinder mixer sections of this manual. Additional preparation is needed to operate the self-contained option.



WARNING: WHEN PREPARING THE TRACTOR AND GRINDER MIXER FOR OPERATION, MAKE SURE PTO IS DISENGAGED, TRATOR ENGINE IS SHUT OFF AND PLACE KEY IN YOUR POCKET.

Preparing the Tractor

The tractor must be equipped with a 1000 or 540 rpm PTO to match the grinder mixer. Make sure the proper PTO is used.

Connect the power cord to a suitable 12 VDC power supply. The tractor must be able to provide 12-15 volts DC and 10 amperes to operate the electrical activated control valve. The Complete Control Box (see Figure 99) is equipped with a 30 amp fuse. See figure 95 for direct connection with the power plug to the battery.

Note: The electrical system of the tractor must be in good working order. If voltage of less than 12.0 volts DC is provided to the actuator or solenoids on hydraulic control valves, the system will not operate properly.

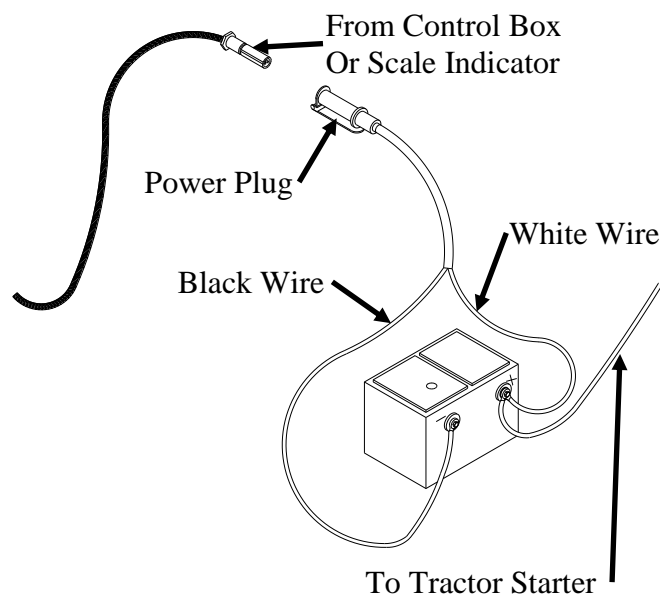

Figure 95 - 12-Volt System power wire hookup to battery

Note: The Control Box power cord can be wired into Scale Box power connector or 6530 7-Pin Light Harness Plug.

PREPARING THE GRINDER MIXER

Electrical Components

Linear Actuator is shipped in Supplement Hopper. Install Actuator base end to the brackets located on the Diagonal Discharge Tube and rod end to the Tabs on the Discharge Gate (see Figure 96). Connect Wire Coupler to coupler on actuator. Apply silicon sealant to the threads of the Indicator Tube and screw it onto the threaded stud on the Discharge Gate.

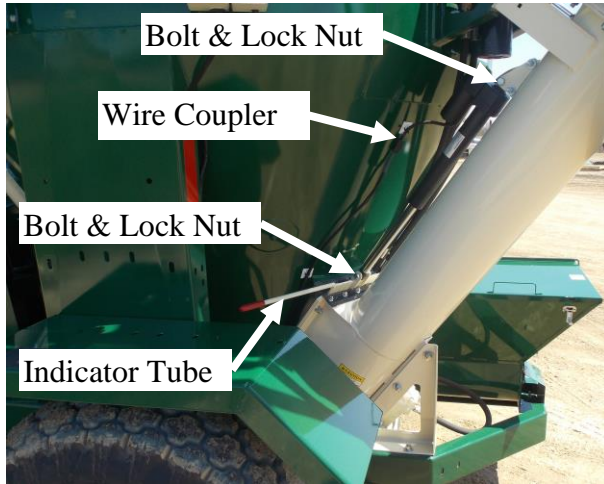

Figure 96 - Actuator installation (shown with the gate in the open position).

Activate the electric linear actuator to open and close discharge gate. It will ratchet when actuator is fully retracted at this point the gate should be fully opened.

The control valve is electrically actuated from a Remote Control device (See Figure 97).



WARNING: TO PREVENT INJURY OR ACCIDENT PLEASE BE AWARE THAT ANY LOADS CONNECTED TO THE RECEIVER MAY BE CYCLED ON AND OFF DURING THE PROGRAMING PROCESS AND SHOULD BE DISCONNECTED FIRST.

REMOTE CONTROL & RECEIVER SETUP

The Remote Control is has a 9-button sealed membrane keypad, a red diagnostics LED and a green transmit LED. The green LED indicator flashes rapidly whenever there is communication between the Remote Control and the Receiver. The red LED indicator starts blinking once every second when the battery voltage is low and requires replacement. It also blinks when there is a problem with the system in the form of an error code. Refer to the **ERROR CODE CHART** in the

SELF CONTAINED: TROUBLE SHOOTING portion of this manual for more information.

NOTE: An internal **rechargeable lithium ion battery** supplies power for the **Macro-Remote Control** (Figure 97).

NOTE: How often the Remote Control is used and how long it is used each time determine the operating life of the battery. To conserve battery power, it is designed to shut off (sleep) after 15 minutes if no buttons are pressed. To check for low battery, turn the Receiver off and leave the Remote Control on. If the Remote Control red LED continues to blink, the battery is low and requires replacement. If the red LED blinks only when the Receiver is on, count the number of blinks and refer to the **ERROR CODE CHART**.

The Remote Control (see Figure 97) is shipped with all button functions in momentary mode and already synchronized with the Receiver (see Figure 98).

DISCHARGE START/STOP BUTTON LATCHING MODE

To set Discharge Start/Stop button to latching mode the remote must be in configuration mode. Remove the cover from the Receiver so the LED's are clearly visible (see Figure 98).

1. Disconnect power to the Receiver.
2. Turn power on Remote Control (POWER button Figure 97).
3. Simultaneously push buttons #1, #4, & #8 (see Figure 97).
4. The Red LED should be flashing on the Remote Control.
5. Reconnect power to the Receiver before proceeding.
6. Push button #8 (Discharge Auger Start/Stop) (see Figure 97).
7. Wait for confirmation by a 1 second flash of green LED on Remote Control.
8. Press and release the POWER button to send these settings to the Receiver.
9. The Receiver will indicate it has learned this by 4 short flashes of its red LED.

NOTE: If the Receiver does not show the 4 short flashes after pressing the POWER button (to send settings to Receiver) as specified above, it has not learned that setting. It will default to the previous setting. For best results, allow about 3 seconds between pushing the #8 button and pressing the POWER (send) button.

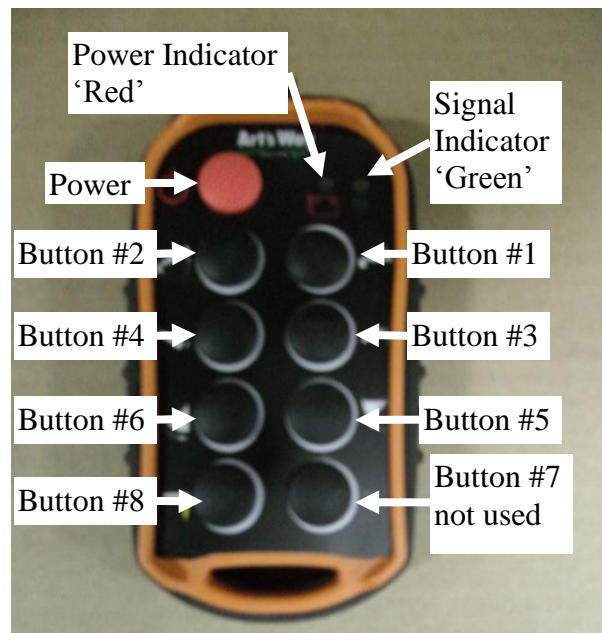

Figure 97 – Macro-Wireless Remote Control device button programming (for functions see Figure 100).

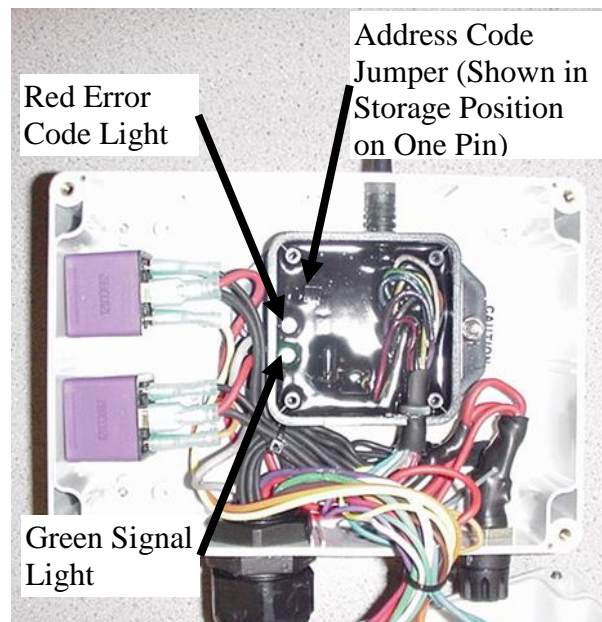

Figure 98 – Receiver in Complete Control Box with covers removed.

NOTE: Each Remote Control is preprogrammed with a unique radio ID code. The Receiver is programmed to respond only to the Remote Control with the ID code for which it is set. Only one Remote Control at a time can be synchronized to the Receiver. This feature allows multiple systems to work in close proximity to one another without interference. In the event that a Remote Control becomes damaged and a new one is needed or the two are not synchronized, the Receiver can be reprogrammed to respond to the new Remote Control.

SYNCHRONIZING RECEIVER TO REMOTE CONTROL

If the Remote Control needs to be synchronized to the Receiver do the following:

1. Remove the cover from both the Complete Control Box and the integrated Receiver (see Figure 98).
2. Apply power to the Receiver.
3. Place the jumper across the both address code pins inside the Receiver (see Figure 98). Both green and red lights will toggle inside the Receiver.
4. Remove the jumper and store it back on one pin.
5. On the Remote Control press and hold the POWER button, button #1, & button #8 (see Figure 97). At this point, both lights will blink on the Remote Control transmitter.
6. Release the POWER button and wait for 1 second or until the green and red lights stop toggling in the Receiver.
7. Release buttons #1 & button #8.
8. Synchronizing is complete.
(Test remote, if not synced, go back and start over at step 1.)
9. Replace the cover on the Receiver.

RESETTING REMOTE CONTROL SLEEP/SHUTOFF TIME

To set the Sleep/Shutoff time of the Remote Control, do the following:

1. With the Remote Control power off press and hold buttons #3, #4, and #8 and then POWER (see Figure 97).
2. Release all the buttons. At this point both lights will blink once per second.
3. Press one of the following buttons to set the sleep time:
 - a. #1 = 15 minutes
 - b. #2 = 30 minutes
 - c. #3 = 1 hour
 - d. #4 = 2 hours
 - e. #8 = sleep disabled
4. Sleep time programming complete.



Figure 99 – Complete Control Box with internal Receiver as Backup Remote Control Box mounted on left rear side of mixer tank (for functions see Figure 104).

NOTE: Complete Control Box with internal Receiver can be run from tractor with an optional 20' extension harness.

COMPLETE CONTROL BOX AS BACKUP REMOTE CONTROL BOX

6530 Grinder Mixer units equipped with the Complete Control Box (see Figure 99) need to flip the **Mode Switch** at the lower left hand corner of the box (see Figure 100) to change control mode settings. Flip the switch to the **Left** for **Remote** control and to the **Right** to run the hydraulics **Manually** from the box.

Switch flipped to **Manual** will shut-off power to **Receiver** in the Complete Control Box.

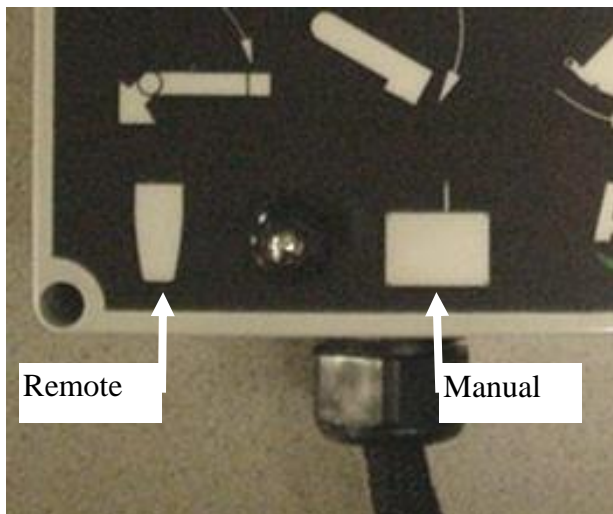

Figure 100 – Mode Switch operation settings for Complete Control Box with internal Receiver.

HYDRAULIC COMPONENTS

Check all connections and fittings for oil leaks.

Check oil level in reservoir. Oil level should be maintained 2-3 inches below top of reservoir.

Run grinder mixer at low rpm 5-10 minutes. During this time, activate all hydraulic motors and cylinders (discharge, lift & swing, auger feeder, and roll feed) to ensure that air is removed from system.

Adjustable valves to control the rate of swing are located in hydraulic control valve. For faster swing, turn control screw out. Set both valves at approximately the same setting. (See **Self Contained: Operation – Discharge Auger Swing Adjustment.**)

Adjustable valve to control the rate of lift and drop of the discharge auger is located in hydraulic control valve. For slower lift, turn control screw in. (See **Self Contained: Operation – Discharge Auger Lift Cylinder Adjustment.**)

Set the pressure relief bypass in valve bank to protect the discharge auger from damage if it contacts an obstacle. (See **Self Contained: Operation – Discharge Auger Lift Cylinder and Swing Pressure Relief Adjustment.**)

Recheck all hydraulic connections and fitting for leaks.

Recheck oil level reservoir.

SELF-CONTAINED: OPERATION



CAUTION: ALWAYS OPERATE PTO AT SPEED FOR WHICH THE MACHINE IS EQUIPED: 1000 RPM. NOTE THE SPEED DECAL ON THE FRONT SHIELD.

The grinder mixer should be run at a slow idle for a few minutes when the temperature drops below 0° F to allow the hydraulic oil to warm up.

For information on operating the auger feeder and roll feed, if your machine is so equipped, see the “Operation of Grinder Mixer” section-pages 25-27, and “Attachments” section, pages 55-56.

All discharge operations (lift, swing, gate, and discharge auger) of the grinder mixer, except for the auger feeder, are functions of the hydraulic control valve. The control valve is electrically activated from a Wireless Remote Control device (see Figure 101) which transmits a signal to the Receiver in the Complete Control Box (see Figure 103), which electrically activates the valves of the Electro-Hydraulic Valve Bank (see Figure 105).

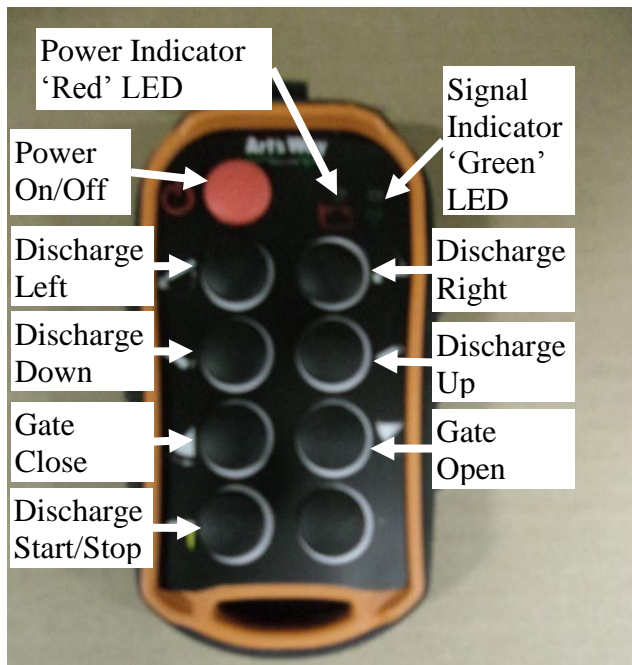

Figure 101 – Macro-Remote Control device functions.



Figure 102 – Macro-Remote Control device with Charger.



Figure 103 – Complete Control Box with internal Receiver mounted on left rear side of tank.

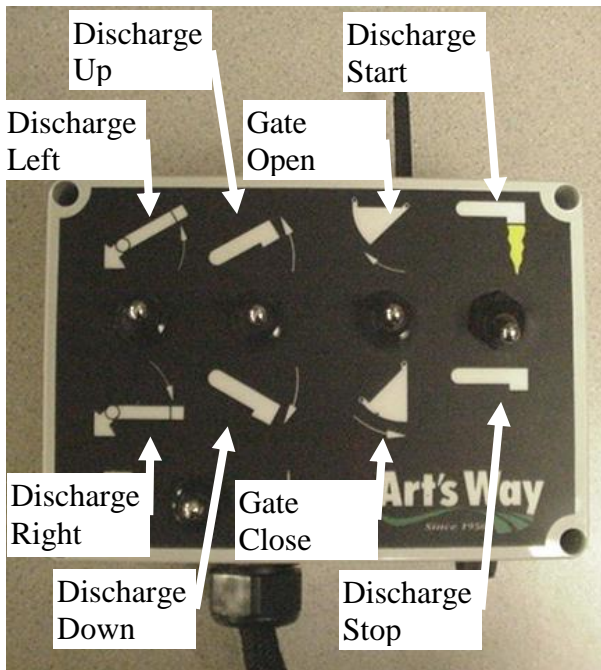

Figure 104 – Switch Functions for Complete Control Box with internal Receiver.

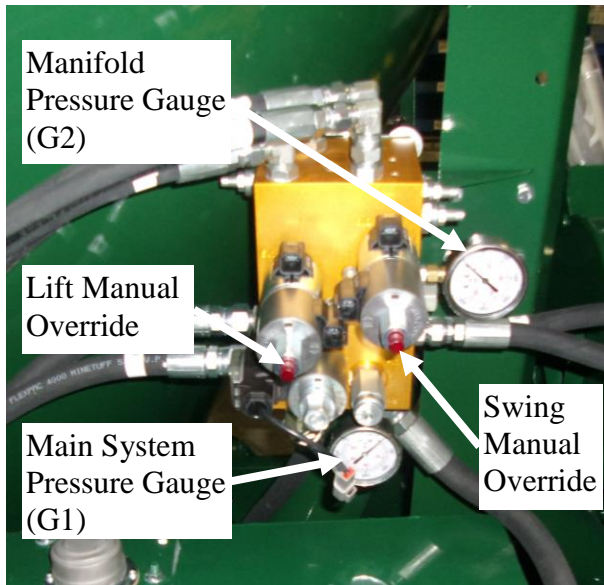

Figure 105 – Electro-Hydraulic Manifold Valve, Manual Overrides, and Pressure Gauges.

If discharge auger or auger feeder becomes clogged with material or foreign objects, the hydraulic motor will stall. When this occurs, the operator must disengage the tractor immediately so the pump and motor will not be damaged from excessive heat. The overloaded material and/or obstruction must be removed before the operation can be continued.

Note: The electrical system of the tractor must be in good working order. If voltage of less than 12.0 volts DC is provided to the actuator or solenoids on hydraulic control valves, the system will not operate properly.



WARNING: BEFORE ATTEMPTING TO CLEAR A BLOCKED AUGER, DISENGAGE PTO, SHUT OFF TRACTOR ENGINE, AND PLACE KEY IN POCKET. FAILURE TO HEED THIS WARNING MAY RESULT IN INJURY.

To **Engage** the Discharge Auger push the Discharge Start/Stop Button on the Remote Control (see Figure 99) or flip the switch up on the Complete Control Box (see Figure 104).

To **Disengage** the Discharge Auger push the Discharge Start/Stop Button on the Remote Control (see Figure 99) or flip the switch down on the Complete Control Box (see Figure 105).

Note: The manifold valve has manual override function if a coil fails on the valve bank. Manual override for each function is the 'red' colored button extending from the end of the solenoid valve (see Figure 105).

Pushing in on the button activates the **swing right** on swing function or the **discharge lower** on the raise/lower function.

Pulling the button out will activate the **swing left** on the swing function or the **discharge raise** on the raise/lower function. A 9/64" dia. hole is located at end of the 'red' colored override button for a 1/8" diameter rod or 1/8" hex wrench sized instrument to help pull the button out with sufficient force to activate the desired function.

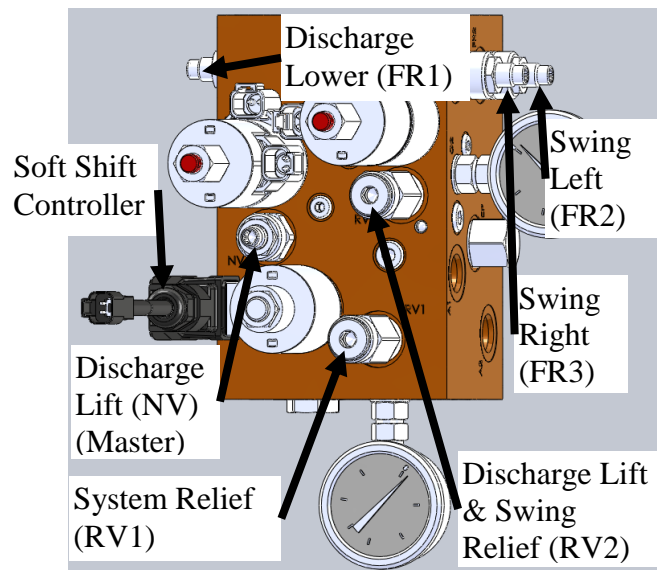

Figure 106 – Adjustment Screws and Manual Override for Discharge Cylinder Lift and Discharge Auger Swing Right.

Note: The discharge lift flow control (NV) is also the master flow control for both the discharge lift cylinder and swing motor (see Figure 106).

DISCHARGE AUGER LIFT CYLINDER ADJUSTMENT

To adjust the speed at which the lift cylinder raises or lowers the discharge auger, loosen the lock nut and turn the valve flow adjustment screw with 1/4" hex wrench for discharge lift (NV) or 3/16" hex wrench for discharge lower (FR1), (clockwise restricts flow, counter-clockwise increases flow). Start by adjusting the discharge lift flow control first (see note above). Then adjust the discharge lower flow control (FR1). The valve flow, when properly adjusted, will also reduce or eliminate jerkiness in the lift cylinders operation.

DISCHARGE AUGER SWING MOTOR ADJUSTMENT

There are two swing flow control valves (see Figure 104), swing right (FR3) and swing left (FR2). To adjust loosen lock nut and turn the valve flow adjustment screw with 3/16" hex wrench to control the speed at which the swing motor turns the discharge auger (clockwise restricts flow, counter-clockwise increases flow). This should be a slow speed to eliminate jump and bounce when activated. The valve flow, when properly adjusted, will also reduce or eliminate jerkiness in the swing motor operation.

DISCHARGE AUGER LIFT CYLINDER AND SWING MOTOR PRESSURE RELIEF ADJUSTMENT

To protect the Discharge Auger from damage when it contacts an obstacle, the relief pressure in the manifold valve needs to be set to the lowest possible setting that still allows the Discharge Auger to both lift and swing properly. Relief valve (RV2) is factory set to 2000 PSI. To adjust the relief, loosen the lock nut and turn the valve flow adjustment screw with 5/16" hex wrench. Turning the screw in increases the relief bypass pressure and conversely turning the screw out will lowers the bypass relief pressure (250 to 3500 PSI range).

CAUTION: *Setting the relief bypass pressure to too high of a setting can cause damage to the Discharge Auger if an obstacle is contacted.*

HYDRAULIC SYSTEM PRESSURE RELIEF ADJUSTMENT

To protect the overall hydraulic system from damage, the relief pressure in the manifold valve (RV1) is factory set to 2500 PSI. To adjust the relief, loosen the lock nut and turn the valve flow adjustment screw with 5/16" hex wrench. Turning

the screw in increases the relief bypass pressure and conversely turning the screw out will lower the bypass relief pressure (250 to 3500 PSI range).

HYDRAULIC DISCHARGE AUGER SOFT SHIFT CONTROLLER

The manifold valve on the 6530 GM is equipped with an electronic soft shift controller (see Figures 106, 107, & 108) that slowly opens the solenoid valve controlling the hydraulic discharge auger motors eliminating the 'bangs' or hydraulic shocks associated with operating a hydraulic valve. The controller is set to jump to a preset 'step' voltage then 'ramp' up to maximum at a preset rate.

The Step Point UP is preset to zero and Ramp UP rate is preset to 6 seconds.

Adjustments can only be made to the High Country Tek Controller (see Figure 107). Adjustments to the settings should not need to be made. Turning the screw clockwise increases the respective value (50mSeconds to 10 second adjustment range).

Note: *Be careful when making adjustments.*

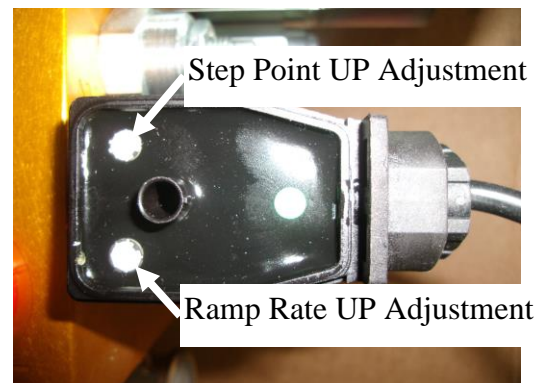

Figure 107 – Discharge Auger Soft Shift Controller (High Country Tek) (shown with cover removed).

The HydraForce Controller (see Figure 108) is preprogrammed from the factory and cannot be adjusted.

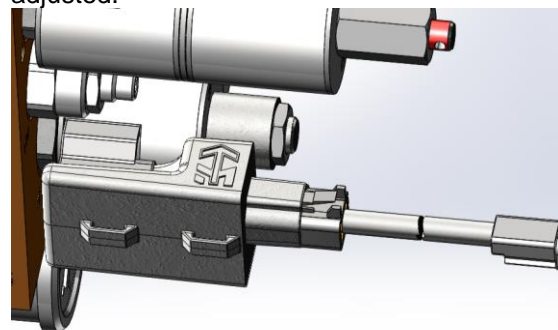

Figure 108 – Discharge Auger Soft Shift Controller (HydraForce)

SELF-CONTAINED: ADJUSTMENT/SERVICE & LUBRICATION



CAUTION: DO NOT CLEAN, ADJUST, OR LUBRICATE THE MACHINE WHILE IT IS RUNNING. MAKE SURE THE ENGINE IS SHUT OFF, PLACE THE KEY IN YOUR POCKET AND DISCONNECT THE IMPLEMENT INPUT DRIVELINE.

MAIN DRIVE CHAIN

Adjust mounting bracket of hydraulic pump so that the sprocket on the hammer mill jack shaft and sprocket on the hydraulic pump are running on center. Tighten bearing and mounting bracket bolts and replace shield. Run grinder mixer slowly and observe hydraulic pump. If pump is in need of further adjustment to better align sprockets; for position of the sprockets see Figure 109. Excessive wear of chain, sprockets, and hydraulic pump will result if sprockets are not centered properly.

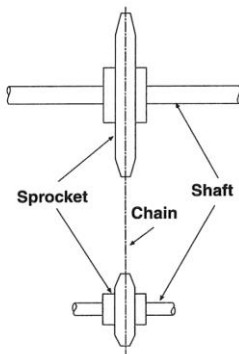

Figure 109 – Sprocket Alignment

HYDRAULIC VALVES

All valves are preset; if they need to be adjusted refer to pages 48 & 49.

LUBRICATION

The chain on the pump coupling should be lubricated periodically with light engine oil.

For other lubrication see the section of this manual beginning on page 33.

HYDRAULIC FILTRATION

The return line filter, mounted on the side of the hydraulic reservoir, traps contaminants before the oil returns to the tank. It is recommended that the element be replaced after the first 100 hours of operation and each 1000 hours or yearly thereafter, whichever occurs first (see Figure 110).

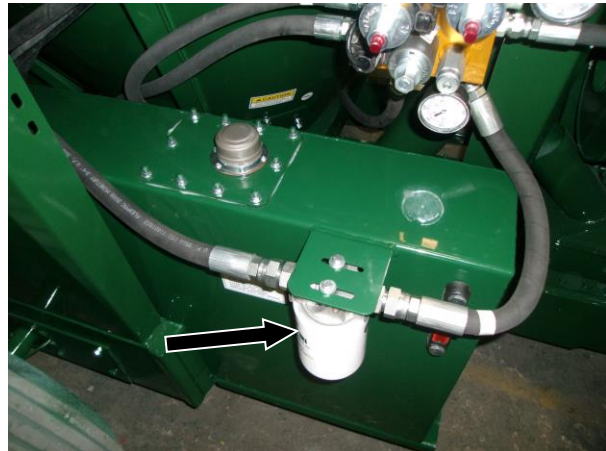

Figure 110 – Reservoir Filter (see Arrow)

A suction strainer is located in the suction port of the hydraulic reservoir tank. Periodically remove and clean it with compressed air, blowing from inside out. If it is damaged or does not cleanup well, replace it with a new strainer (see Figure 111).

IMPORTANT: A clogged strainer increases the chances of cavitation occurring in the intake line and subsequent damage to, and failure of the hydraulic pump caused by a lack of hydraulic fluid flowing through the pump.

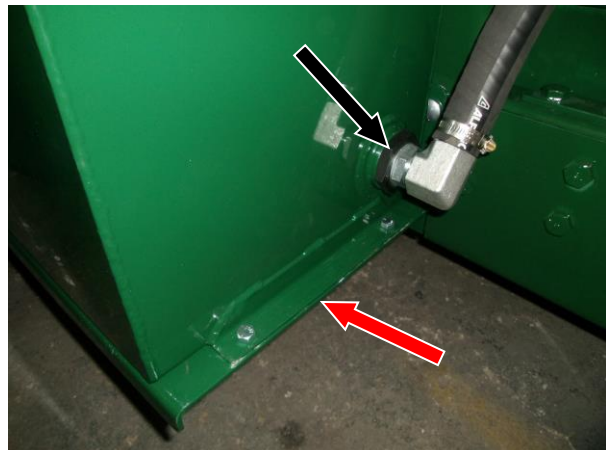

Figure 111 – Reservoir Strainer (black arrow) and Drain underneath reservoir tank base (red arrow).

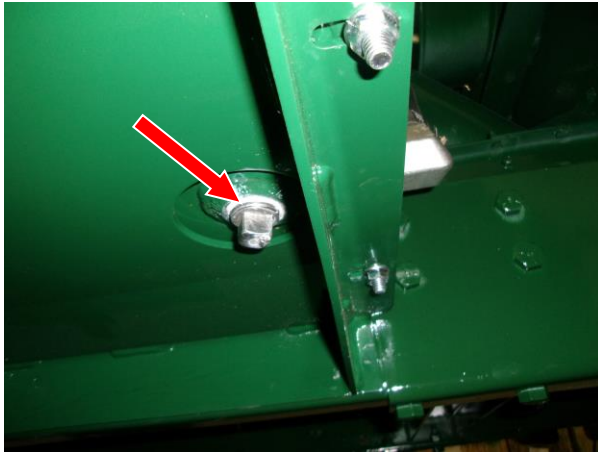

Figure 112 – Drain underneath reservoir tank base (red arrow).

Installed in the drain port of the hydraulic reservoir tank is a magnetic pipe plug. When hydraulic oil is changed, this plug should be removed and any metal particles removed from it (see Figures 111 & 112).

NOTE: *New hydraulic oil is not necessarily free from contaminants. New hydraulic oil straight from the drum has a typical cleanliness level of ISO 4406 23/21/18. To add hydraulic oil, and not the dirt, always filter new oil prior to use in a hydraulic system. This can be accomplished by pumping the oil into the hydraulic reservoir through the system's return filter. The easiest way to do this is to install a tee in the return line and attach a quick-connector to the branch of this tee. Attach the other half of the quick-connector to the discharge hose of a drum pump. When hydraulic oil needs to be added to the reservoir, the drum pump is coupled to the return line and the oil is pumped*

into the reservoir through the return filter. As well as filtering the oil, spills are avoided and the ingress of external contamination is prevented.

FILLER/BREATHER FILTER

When adding hydraulic oil, back blow through the filler cap with low pressure air. If the filler screen is dirty, remove the ten (10) – 5/16" whiz nuts on the access cover and flush screen with solvent and allow too dry before installing. Prior to replacing the access cover, remove the old gasket material from the cover and tank, then replace gasket material using silicone blue (see Figure 113).

If lack of pressure or flow is experienced, check strainer and/or replace filter. Regular servicing of the filter and preventing contaminants from entering the hydraulic oil is the best assurance of reliable and economic operation.

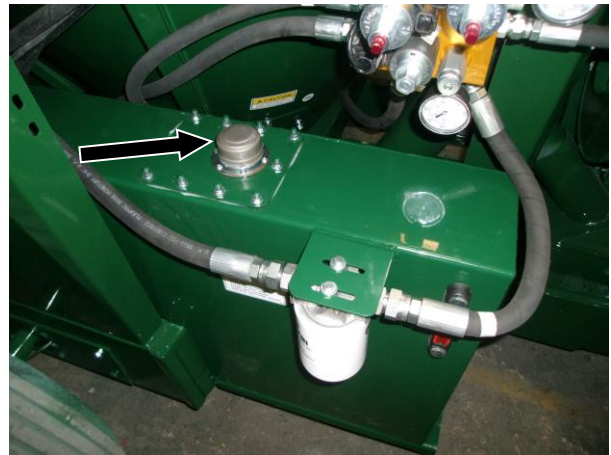

Figure 113 – Hydraulic Reservoir Cap (see Arrow)

SELF CONTAINED: TROUBLESHOOTING GUIDE

The majority of difficulties are caused by improper adjustments. When you encounter trouble, perform a systematic check of all possible adjustments using the chart that follows. If difficulties cannot be corrected by making the adjustments that follow, consult your local Art's Way authorized dealer for further assistance.

TROUBLE	POSSIBLE CAUSE	POSSIBLE REMEDY
No functions work on wireless remote control	Wireless remote control is turned off	Turn power on wireless remote control
	Batteries in wireless remote control are weak or drained	Recharge internal batteries on Macro-remote control
	Something is blocking signal from wireless remote control to receiver	Move to location with clear line of site from wireless remote control to receiver
	No power to receiver, control box, and/or electro-hydraulic valve bank	Flip mode switch to Remote Control on Complete Control Box Check connections to battery Check connections from tractor to grinder Check connections on control box Check connections on electro-hydraulic valve bank Check for severed wires
	Wireless remote control is not synchronized with receiver	Resynchronize wireless remote control with receiver (see Synchronizing Remote Control to Receiver)
	Fault in system	Check LED status display for possible fault or error indication of system status (see Remote Control Error Codes below)
	Mode Switch is on Manual	Flip switch to Remote (see Figure 100)
Certain functions on wireless remote control do not work or Functions operate intermittently	Something is blocking signal from wireless remote control to receiver	Move to location with clear line of site from wireless remote control to receiver
	Bad wire or loose connection to valve coil	Check the wiring connection from the Control Box to the valve coil for the output function that does not work
		Reseat connector at valve coil
	Receiver antenna improperly connected or damaged	Check Receiver connections Replace Receiver
	Fault in system	Check LED status display for possible fault or error indication of system status (see Remote Control Error Codes below)
Bad valve coil	Replace coil	
Discharge auger will not lift and/or swing	Wireless remote control and/or receiver not working	Check wireless remote control/receiver as above
	Improper voltage or amperes	Use tractor that will provide 12-15 volts DC and 10 amperes

	Loose electrical connections	Check connections to battery Check connections from tractor to grinder Check connections on control box Check connections on electro-hydraulic valve bank Check for severed wires
	Low hydraulic fluid level	Fill reservoir to proper level
	Hydraulic fluid leak	Check all fittings and hoses for leaks
	Relief bypass in manifold valve set at too low of pressure	Increase relief valve pressure
	Contamination in valves	Remove and clean cartridge valves
	Faulty relief valve	Replace relief valve
	Adjustable valves closed	Open valves
	Air in hydraulic lines	Run grinder mixer at low rpm 5-10 minutes. During this time, activate all hydraulic motors and cylinders to ensure that air is removed from system.
	Bad valve coil	Replace coil
Discharge auger will not run	Improper voltage or amperes	Use tractor that will provide 12-15 volts DC and 10 amperes
	Loose electrical connections	Check electrical connection as above
	Bad soft shift controller	Replace soft shift controller
	Low hydraulic fluid level	Fill reservoir to proper level
	Hydraulic fluid leak	Check all fittings and hoses for leaks
	Bad manifold coil	Replace coil
Discharge door will not open	Actuator not operating	Check electrical connection as above
	Improper voltage or amperes	Use tractor that will provide 12-15 volts DC and 10 amperes
Hydraulic motors run hot	Low hydraulic fluid level	Fill reservoir to proper level
Hydraulic system runs slow	RPM's from tractor has fallen below required level	Increase PTO's speed to: -1000 but not more than 1050 RPM for 1000 RPM PTOs -540 but not more than 565 RPM for 540 RPM PTOs
	Clogged filter or strainer	Replace filter Clean strainer
	Low hydraulic fluid level	Fill reservoir to proper level
	Hydraulic fluid has thicken from the cold (winter operation)	Run for 10 to 15 minutes to warm up and thin fluid

SELF CONTAINED: REMOTE CONTROL ERROR CODES

Count the number of blinks on the receiver or the wireless remote control red LED.

ERROR CODE	PROBABLE CAUSE
1 Blink	Radio signal problem
2 Blink	Short or open connection at output 1 (White Wire to Receiver)
3 Blink	Short or open connection at output 2 (Green Wire to Receiver)
4 Blink	Short or open connection at output 3 (Blue Wire to Receiver)
5 Blink	Short or open connection at output 4 (Brown Wire to Receiver)
6 Blink	Short or open connection at output 5 (Yellow Wire to Receiver)
7 Blink	Short or open connection at output 6 (Orange Wire to Receiver)
8 Blink	Short or open connection at output 7 (Gray Wire to Receiver) <i>NOT USED</i>
9 Blink	Short or open connection at output 8 (Purple Wire to Receiver)

There are no user-serviceable parts inside the wireless remote control or the receiver. Return the units for service.

ATTACHMENTS

ELECTRONIC SCALE ATTACHMENT

A solid state electronic scale attachment, digital type, is available for your grinder mixer. The scale attachment consists of weigh bar sensors mounted on the grinder mixers axle spindles and hitch. They are electronically connected to the indicator bars. The indicator alarm system is available with the electronic scale attachment. Scale accuracies of 1 percent or less are obtained. Complete installation and operating instructions are included with the attachment.

ADJUSTABLE SCALE ARM ATTACHMENT

The optional scale arm allows the electronic scale to be positioned along a 180° arc off the side of the grinder (see Figure 114). Tension on the pivot point spring can be increased or decreased by tightening or loosening the nut. Periodic grease needs to be applied to the zerk on the pivot point.

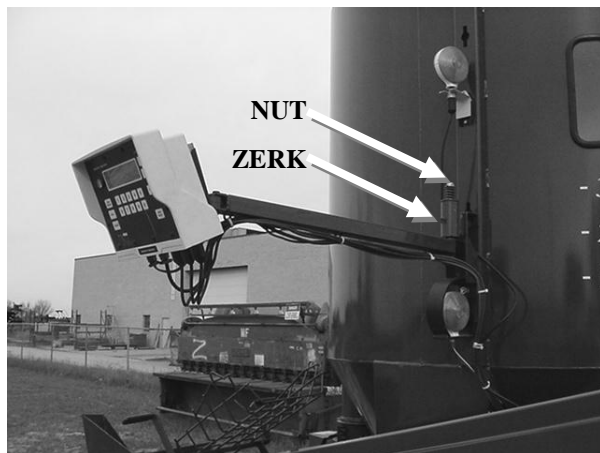

Figure 114 – Adjustable Scale Arm Attachment

DISCHARGE UNLOADING AUGER EXTENSIONS

3 foot and 6 foot folding and 3 foot and 6 foot bolt-on discharge auger extensions are available (see Figure 115). For unloading height obtainable with various extensions added to the unloading auger system, refer to Table 4. For unloading auger instructions, refer to OPERATION OF GRINDER MIXER section.

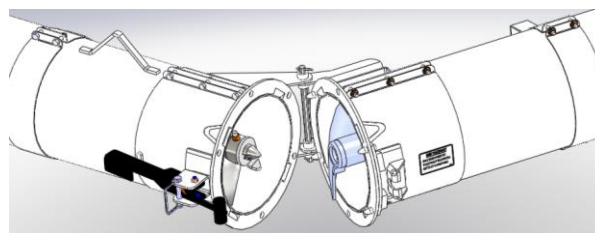

Figure 115 - Folding Auger Extension.

SCREENS

Screens for hammer mills are available in 12 sizes ranging from 1/8 inch to 2 inch. Refer to OPERATION OF GRINDER MIXER – Hammer mill Screens.

HYDRAULIC ROLL FEED

The hydraulic roll feed provides easier feeding of exceptionally coarse material such as ear corn, corn cobs or hay. Additional protection is provided for the operator and more even particle size will be obtained (see Figure 116).

To maintain even feeding, the roll feed may be set at a desired height by using the roll feed crank. Roll feed settings will vary with the material being fed. Brief experience will indicate the best settings. Set the roll feed just high enough so that the material is being pulled smoothly.

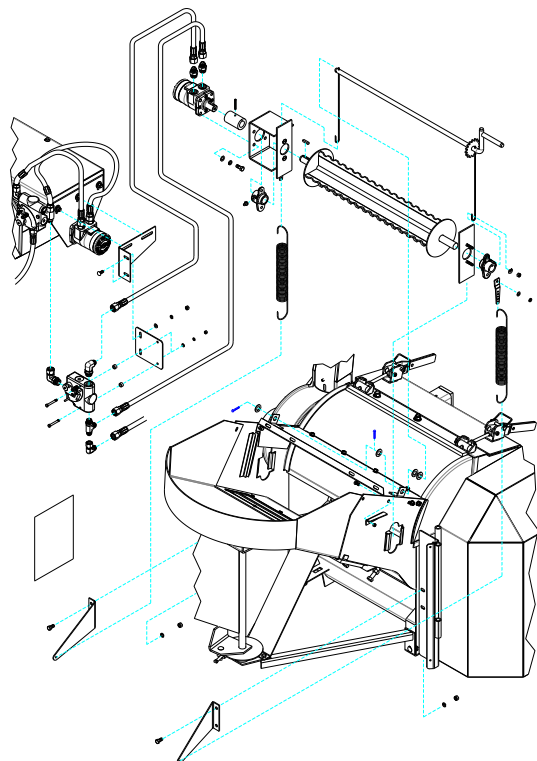

Figure 116 - Roll Feed With Auger Feeder Shown.



CAUTION: NEVER FORCE MATERIAL INTO THE ROLL FEED WITH A STICK OR WITH HANDS. BE ESPECIALLY CAREFUL WHEN FEEDING SLICES OF HAY, ALWAYS ALLOWING THE ROLL FEED TO PULL THE HAY INTO THE MILL.

The hydraulic roll feed is connected in series with the hydraulic auger feeder. A separate flow control valve allows separate speed control for the roll feed. If equipped with the hydraulic roll feed only, the flow control is on top of the hammer mill. The crank for lowering the roll feed is toward the front of the hammer mill housing (see Figure 117).



Figure 117 - Roll Feed And Auger Feeder Flow Control Valves.

ROLL FEED ADJUSTMENT

Five holes are provided at the upper end of the roll feed spring. The roll feed tension can be changed as desired. Generally, the top hole is used for hay (see Figure 118).

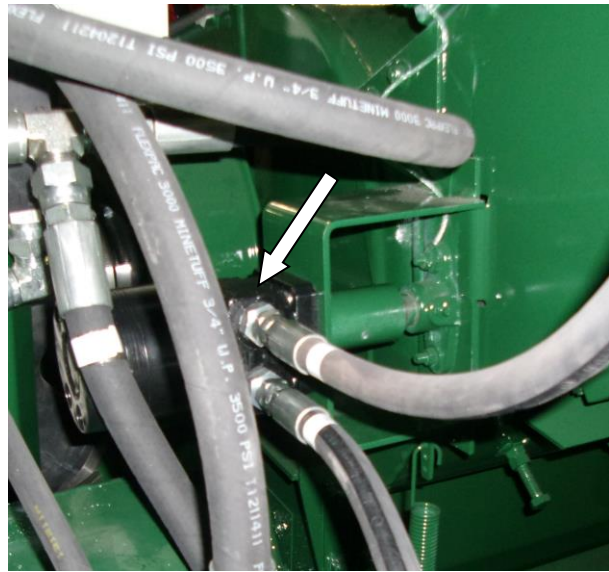

Figure 118 – Hydraulic Roll Feed Motor.

If the roll feed does not crank up straight, check the cables at each side of the roll feed to see if they are both uniform on the roll feed crank shaft (see Figure 119).



Figure 119 – Roll Feed Crank.

Cable lengths can be adjusted by loosening the nut with the special cable washer and retightened after the cables have been equalized.

SPECIFICATIONS

TANK AND FRAME

- Capacity of mixing tank: 165 bu. /206 cu. ft.
- Height (variable with tire size): 126 inches.
- Width without auger feeder:..... 111 inches.
- Overall length:..... 175 inches.
- Weight:.....5150 lbs.

DISCHARGE AUGER

- Auger diameter:9-3/16 inches.
- Auger tube diameter: 10 inches.
- Horizontal operating arc: 225°
- Vertical operating arc:..... +46° to -27° or +60° to -11°

AUGER FEEDER

- Auger length: 100 inches.
- Auger diameter: 10 inches.
- Hopper width open: 43 inches.
- Height of hopper from ground in down position:..... 16-1/2 inches.
- Height of hopper from ground in up position: 60 inches.

MIXING AUGER

- Auger width..... 12 inches.
- Mixing base..... 24 inches.

SUPPLEMENT HOPPER

- Auger diameter 7 inches.
- Hopper size..... 21 inches X 24 inches
- Height from ground 39 inches

HAMMERMILLS

- Tank and frame 26 inches
- Width of mill Full 26 inches
- Screen area 780 sq. in.
- Operating speed 540 or 1,000 RPM
- Operating speed of mill..... 2,800 to 3,000 RPM
- Screen sizes available 1/8, 5/32, 3/16, 1/4, 3/8, 1/2, 5/8,
3/4, 1, 1-1/4, 1-1/2, and 2 inch
- Type drive Six double banded 3V belts for 540 or 1,000 RPM

POWER REQUIRED 80 to 150 HP

SPECIFICATIONS: SELF-CONTAINED HYDRAULICS

PUMP

- **Type:** Gear Driven Positive Displacement
- **Displacement:** 3.869 cu. in. per revolution
- **Flow (GPM):** 15.6 gallons per minute @ 1000 RPM
- **Input HP Required:** 26.43 HP @ 2500 PSI

HYDRAULIC RESERVOIR

- **Type:** Fabricated pickled and oiled steel
- **Capacity:** 36 gallons
- **Ports:**
 - Suction: -24 ORB (1-7/8-12 SAE)
 - Return: -16 ORB (1-1/16-12 SAE)
 - Drain: 3/4" NPT

FILTERS/STRAINERS/BREATHERS/ INDICATORS

Tank Mounted Suction Strainer

- **Flow Capacity:** 15 GPM
- **Style:** Suction Type
- **Screen Size:** 100 Mesh
- **Thread Size:** -24 ORB (1-7/8-12 SAE) male
 - -16 ORB (1-5/16-12 SAE) female

Tank Mounted Filler Breather

- **Breather Filler:** 40 Micron
- **Strainer Basket:** 30 Mesh

Tank Mounted Temperature/Level Gauge

- **Material:** 40 Micron
- **Strainer Basket:** 30 Mesh

Return Line Filter

- **Material:** Head-Cast Aluminum, Spin-on Canister-Steel, Seals-Nitrile, standard
- **Pressure Rating:** 250 PSI maximum operating, Caution: 80 PSI with Blocked Bypass
- **Temperature Range:** -40°F to +250°F
- **Filtration:** 10 Micron nominal
- **Flow:** 20 GPM
- **Internal Bypass:** Relieves at 15 PSI differential
- **Port Size:** -12 ORB (1-1/16-12 SAE)

HYDRAULIC MOTORS

Auger Feeder/Roll Feeder

- **Type:** Gear, low speed high torque
- **Displacement:** 11.3 cu. in. per revolution
- **Flow (GPM):** 15 GPM cont., 20 GPM inter.
- **Pressure Rating:** 1600 PSI cont., 2150 PSI inter.
- **Ports:** -10 ORB (7/8-14 SAE)

Discharge Auger

- **Type:** Gear, low speed high torque
- **Displacement:** 9.6 cu. in. per revolution
- **Flow (GPM):** 20 GPM cont., 30 GPM inter.
- **Pressure Rating:** 3000 PSI cont., 3750 PSI inter., 4500 max.
- **Ports:** -10 ORB (7/8-14 SAE)

Discharge Swing

- **Type:** Gear, low speed high torque
- **Displacement:** 22.6 cu. in. per revolution
- **Flow (GPM):** 15 GPM cont., 20 GPM inter.
- **Pressure Rating:** 1250 PSI cont., 1500 PSI inter.
- **Ports:** -10 ORB (7/8-14 SAE)

MANIFOLD VALVE ASSEMBLY

Directional Valve Assembly: Consisting of (2) solenoid operated 3-position 4-way tandem center spool valves and (1) solenoid operated proportional 2-way poppet valve mounted on a common manifold with (3) pressure compensated flow controls, (1) needle valve (2) built-in relief valves and (2) stem mount 3000 PSI pressure gauges.

Manifold Valve Assembly

- **Type:** Custom Manifold Block
- **Material:** 6061-T6 Aluminum, Gold Anodized
- **Solenoids:** 12 VDC Electric
- **Flow:** System design 16-20 GPM, Max. 25 GPM
- **Max. Pressure:** 3000 PSI @ A1,A2,D1,D2,S1,S2, LD,UD, 3500 PSI @P, T
- **Max. Fluid Contamination:** Class 21/18/15 to ISO 4406
- **Temperature Range:** -40°F to +248°F Seals

- **Port Sizes:** P: -12 ORB (1-1/16-12 SAE)
 - T: -12 ORB (1-1/16-12 SAE)
 - LD,UD: -10 ORB (7/8-14 SAE)
 - A1,A2,D1,D2,S1,S2: -8 ORB (3/4-16 SAE)

Solenoid Valve SP (Manifold Valve Assembly)

- **Material:** Steel
- **Type:** Proportional solenoid-operated, 2-way, poppet-type, normally open, hydraulic cartridge
- **Solenoid:** 12 VDC Electric w/DIN 43650 connector
- **Flow:** 70 GPM Max.
- **Operating Pressure:** 3625 PSI

Soft Start Controller (Manifold Valve Assembly)

- **Housing Material:** High impact resistance ABS
- **Input Voltage:** +10 to +30 VDC
- **Solenoid Connector:** DIN 43650 connector
- **Wire Connector:** Deutsch DTO4-2P connector
- **Preset Ramp up Rate:** 6 sec.
- **Preset Ramp down Rate:** 0 sec.
- **Temperature Range:** -4°F to +158°F
- **NEMA/IP Rating:** NEMA 6/IP65 when assembled

Solenoid Valves SV1 & SV2 (Manifold Valve Assembly)

- **Material:** Steel
- **Type:** Solenoid-operated, 4-way, 3-position, direct-acting, spool-type, tandem center, w/manual override
- **Solenoid:** 12 VDC Electric w/Deutsch DTO4-2P connector
- **Flow:** 5 GPM Max.
- **Operating Pressure:** 3500 PSI

Flow Control Valves FR1, FR2, & FR3 (Manifold Valve Assembly)

- **Material:** Steel
- **Type:** Cartridge-style, adjustable, pressure-compensated, restrictive-type hydraulic flow regulating
- **Flow Range:** 0.1-3 GPM
- **Maximum Pressure:** 5000 PSI

Needle Valve NV (Manifold Valve Assembly)

- **Material:** Steel
- **Type:** Cartridge-style, variable orifice, hydraulic flow restrictor
- **Flow Range:** 12 GPM
- **Maximum Pressure:** 3500 PSI

Relief Valves RV1 & RV2 (Manifold Valve Assembly)

- **Material:** Steel
- **Type:** Cartridge-style, direct-acting, differential area poppet-type hydraulic relief
- **Pressure:** Preset @2500 PSI
- **Adjustable Pressure Range:** 250 - 3500 PSI

Logic Element EP (Manifold Valve Assembly)

- **Material:** Steel cartridge with anodized high-strength 6061-T6 aluminum body
- **Type:** Spool-type, cartridge-style, hydraulic directional element
- **Flow Range:** 0-20 GPM
- **Pressure Setting:** 80 PSI
- **Maximum Pressure:** 3000 PSI

Check Valve CV (Manifold Valve Assembly)

- **Material:** Steel
- **Type:** Cartridge-style, hydraulic check
- **Flow Range:** 0-20 GPM
- **Pressure Setting:** 5 PSI
- **Maximum Pressure:** 3500 PSI

Pilot Check Valve PC (Manifold Valve Assembly)

- **Material:** Steel
- **Type:** Cartridge-style, pilot operated, hydraulic check
- **Pilot Ratio:** 4:1
- **Flow Range:** 0-8 GPM
- **Pressure Setting:** 30 PSI
- **Maximum Pressure:** 3500 PSI

Pressure Gauges G1 & G2 (Manifold Valve Assembly)

- **Material:** Steel
- **Type:** 2-1/2 inch stem mount
- **Pressure Range:** 0 - 3000 PSI

Adjustable Flow Control (Auger Feeder)

- **Material:** Steel
- **Flow Range:** 0-16 GPM
- **Maximum Pressure:** 3000 PSI
- **Port Size:** -10 ORB (7/8-14 SAE)

ELECTRIC ACTUATOR

- **Type:** 12 VDC
- **Load Rating:** 250 lbs.
- **Stroke Length:** 12 inches
- **Overload Protection:** Ball detent overload clutch
- **Drive:** Acme screw thread

ELECTRIC CONTROL BOX

- **Type:** 12 VDC
- **Circuit Breaker:** 30 amp Fuse in Complete Control Box

WIRELESS REMOTE CONTROL

- **Power Supply:** Internal rechargeable lithium ion battery. **Battery Life continuous operation:** 35-40 hours.
- **Operating Temperature - Radio:** -40°F to +185°F
- **Storage Temperature:** -40°F to +212°F
- **RF Frequency:** 902-928 MHz
- **RF Transmit power (EIRP):** 10 mW
- **Range:** 100 m (328 ft.) nominal, greater line of sight
- **Vibration:** 3G to 200Hz
- **Shock:** 50G
- **Ingress Protection:** IP65 Remote Control Receiver
- **Power Supply Voltage:** 9-30VDC
- **Operating Temperature:** -40°F to +185°F
- **Storage Temperature:** -40°F to +212°F
- **Outputs:** 3.0-5.0A, sourcing (20A system max.)
- **RF Frequency:** 902-928 MHz
- **RF Transmit power (EIRP):** 10 mW
- **Range:** 100 m (328 ft.) nominal, greater line of sight
- **Vibration:** 3G to 200Hz
- **Shock:** 100G

SCHEMATICS: TRACTOR HYDRAULICS

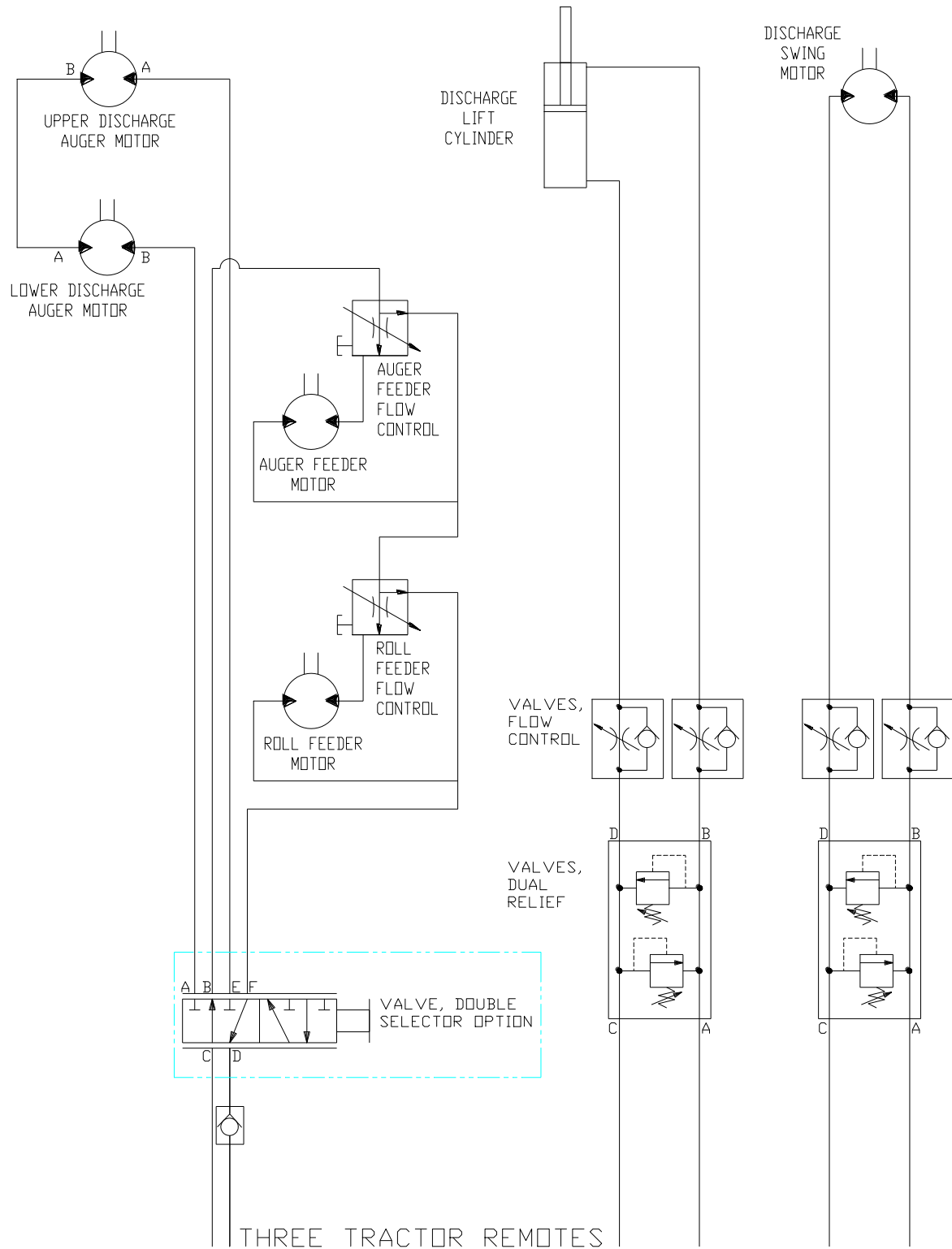

SCHEMATICS: SELF-CONTAINED HYDRAULICS

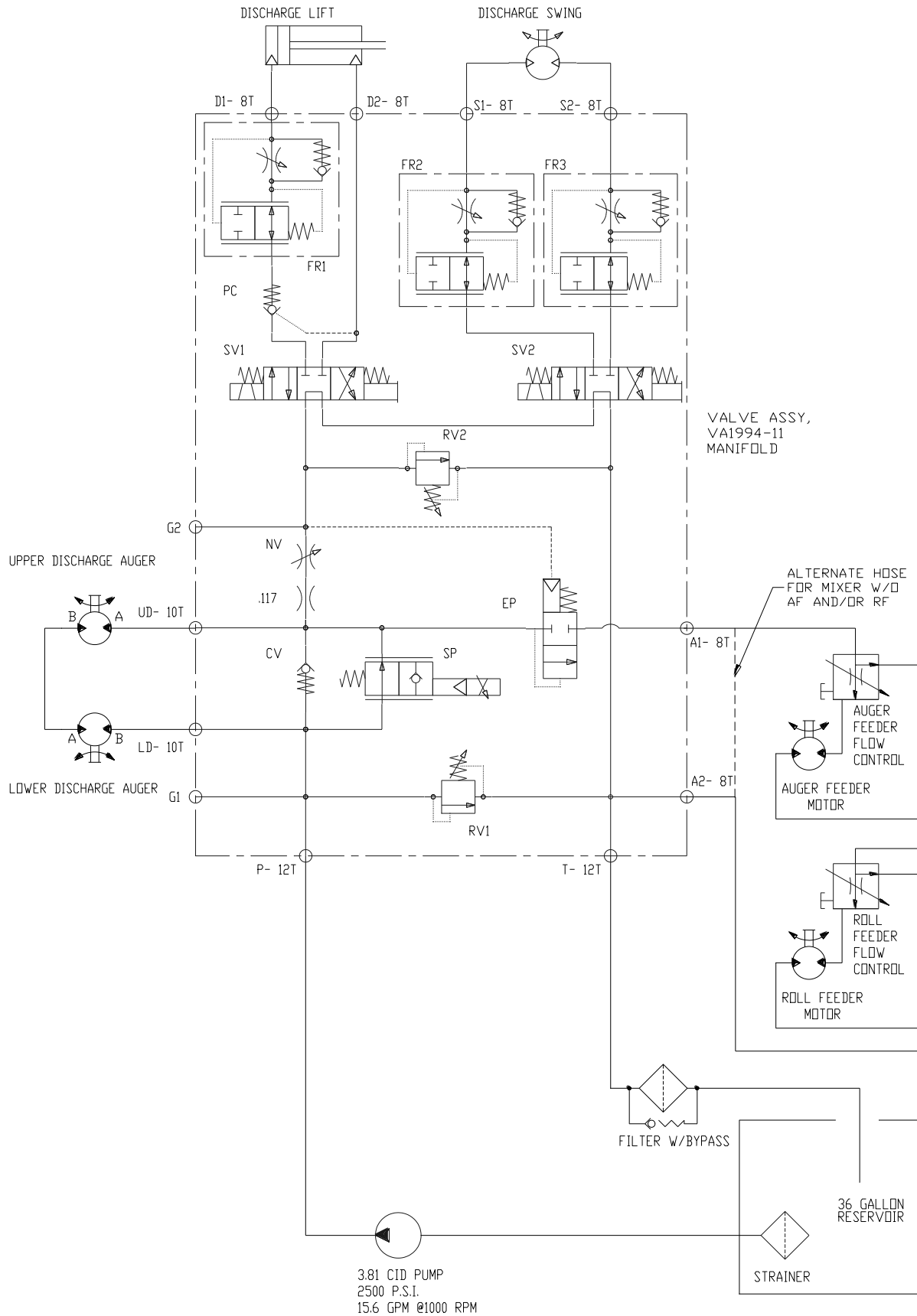

SCHEMATICS: SELF-CONTAINED WIRING

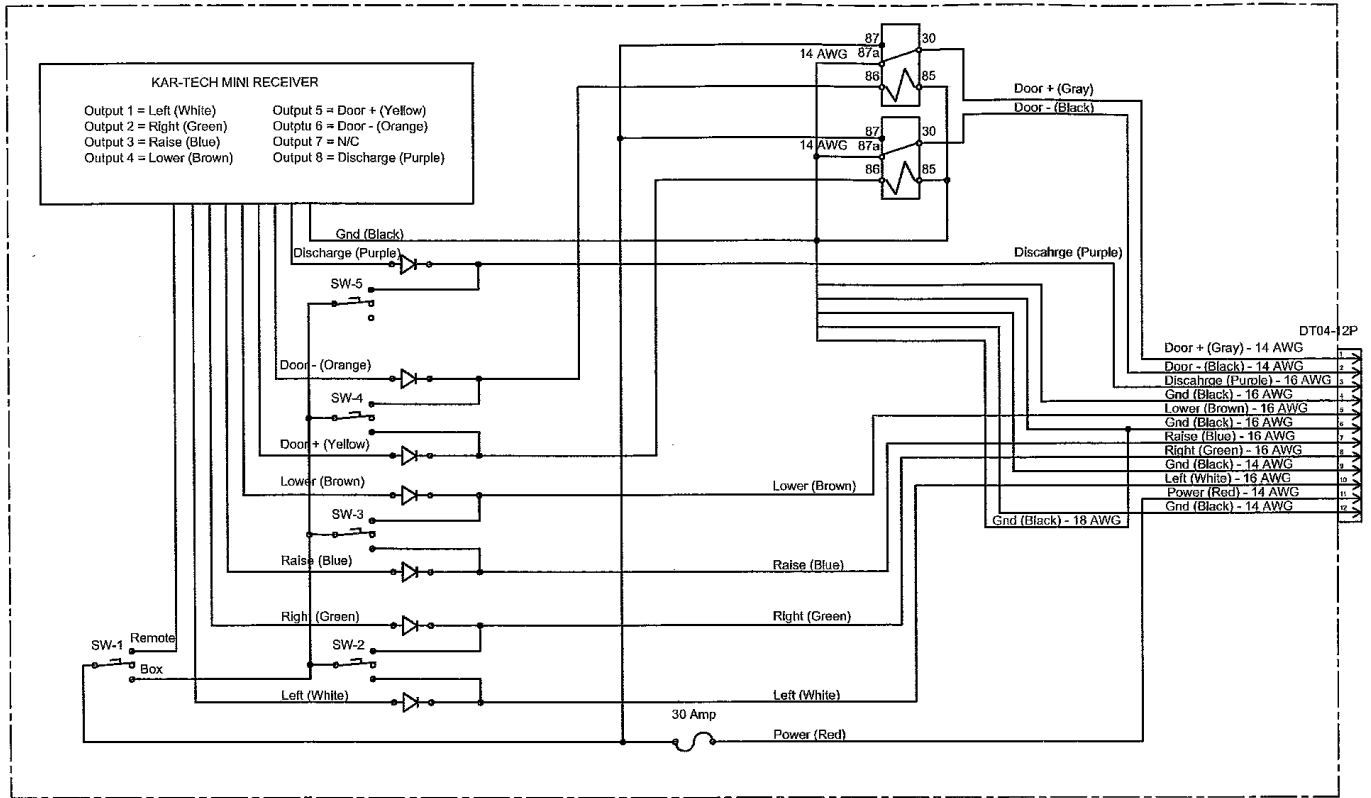

CONTROL BOX WITH 4 FT. WIRING HARNESS

Packard 56 Series Female

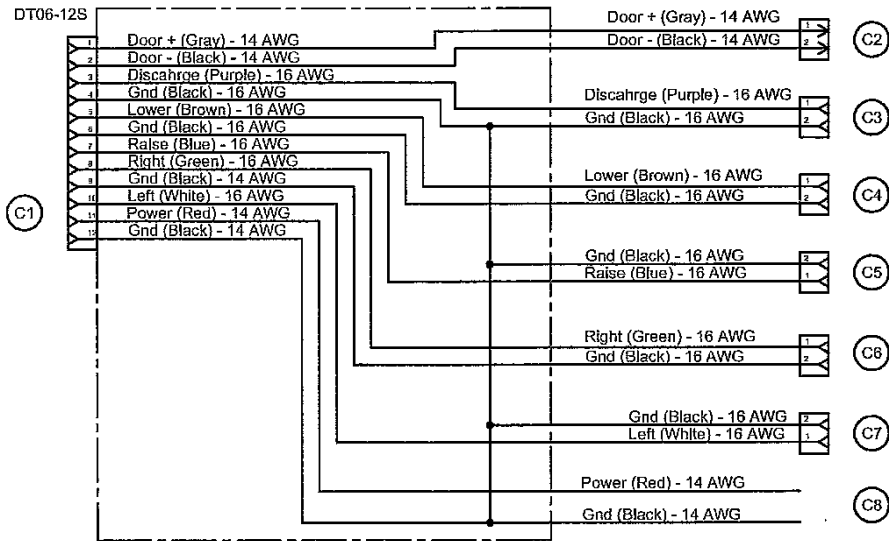

DT06-2S
Sockets #0462-201-16141
Wedge W2S
5 Places Typ

WIRING HARNESS VALVE BANK, MANIFOLD, & ACTUATOR

SCHEMATICS: SELF-CONTAINED WIRING

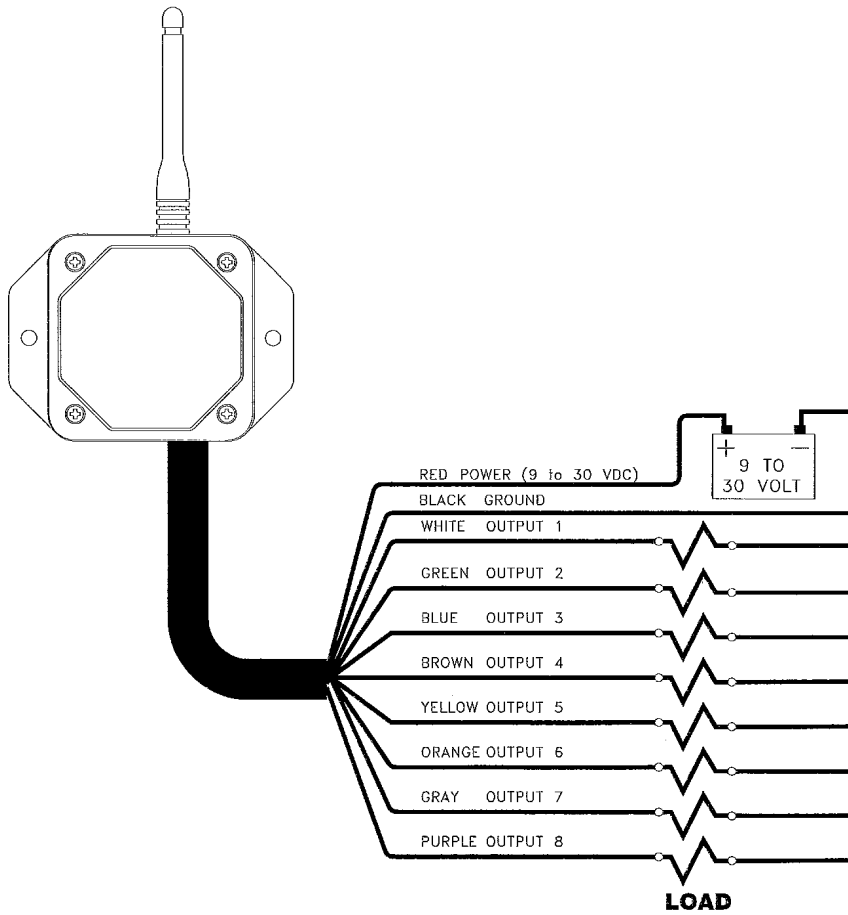

RECEIVER 8-OUTPUT

DT06-12S

DT04-12P

1	Door + (Gray) - 14 AWG	1
2	Door - (Black) - 14 AWG	2
3	Discharge (Purple) - 16 AWG	3
4	Gnd (Black) - 16 AWG	4
5	Lower (Brown) - 16 AWG	5
6	Gnd (Black) - 16 AWG	6
7	Raise (Blue) - 16 AWG	7
8	Right (Green) - 16 AWG	8
9	Gnd (Black) - 14 AWG	9
10	Left (White) - 16 AWG	10
11	Power (Red) - 14 AWG	11
12	Gnd (Black) - 14 AWG	12

OPTIONAL 20 FT. WIRE HARNESS EXTENSION



ART'S-WAY MANUFACTURING CO., INC. TECHNICAL MANUALS

Manuals are available from your local dealer or Art's-Way Manufacturing Co., Inc. for the operation, service, and repair of your machine. For prompt convenient service, contact your local dealer for assistance in obtaining the manuals for your machine.

Your local dealer can expedite your order for operator manuals, illustrated parts catalogs, service manuals, and maintenance records.

Always give the Machine Name, Model, and Serial Number so your local dealer can provide the correct manuals for your machine.

Art's-Way Manufacturing Co., Inc. reserves the right to make improvements in design or changes in specifications at any time without incurring any obligation to install them on units previously sold.

Except as expressly authorized, no part of this manual may be reproduced, copied, transmitted, disseminated, downloaded or stored in any storage medium, for any purpose without the express prior written consent of Art's-Way Manufacturing Co., Inc.

**ART'S-WAY MANUFACTURING CO., INC.
HWY 9 WEST - PO Box 288
Armstrong, IA. 50514 U.S.A**

© Copyright 2010
ART'S-WAY MANUFACTURING CO., INC.
All Rights Reserved



Art's-Way Manufacturing Co., Inc.
Hwy 9 West – PO Box 288
Armstrong, IA. 50514 U.S.A