



Art's-Way Manufacturing Co., Inc.

Model 6140 Cattlemaxx
Grinder Mixer

Operator's Manual
615680
Issued 07-2020

O P E R A T O R ' S M A N U A L



*This symbol means **ATTENTION! BECOME ALERT! YOUR SAFETY IS INVOLVED.** The message that follows the symbol contains important information about your safety. Carefully read the message. Make sure you fully understand the causes of possible injury or death.*

IF THIS MACHINE IS USED BY AN EMPLOYEE, IS LOANED, OR IS RENTED, MAKE SURE THAT THE OPERATOR UNDERSTANDS THE TWO INSTRUCTIONS BELOW.

BEFORE THE OPERATOR STARTS THE ENGINE:

1. GIVE INSTRUCTIONS TO THE OPERATOR ABOUT SAFE AND CORRECT USE OF THE MACHINE.
2. MAKE SURE THE OPERATOR READS AND UNDERSTANDS THE OPERATOR'S MANUAL FOR THIS MACHINE.

WARNING

IMPROPER OPERATION OF THIS MACHINE CAN CAUSE INJURY OR DEATH.

BEFORE STARTING THE ENGINE, DO THE FOLLOWING:

1. READ THE OPERATOR'S MANUAL.
2. READ ALL SAFETY DECALS ON THE MACHINE.
3. CLEAR THE AREA OF OTHER PERSONS.

LEARN AND PRACTICE SAFE USE OF MACHINE CONTROLS IN A SAFE AND CLEAR AREA BEFORE YOU OPERATE THIS MACHINE ON A JOB SITE.

It is your responsibility to observe pertinent laws and regulations and to follow manufacturer's instructions on machine operation and maintenance.

See your Authorized Art's-Way Manufacturing Co., Inc. dealer or Art's-Way Manufacturing Co., Inc. for additional operator's manuals, illustrated parts catalogs, and service manuals.

TO THE OWNER

Congratulations on the purchase of your new Art's-Way 6140 Grinder Mixer. You have selected a top quality machine that is designed and built with pride to ensure you have many years of efficient and reliable service.

Many people have worked on the design, production, and delivery of this 6140 Grinder Mixer. The information in this Manual is based on the knowledge, study, and experience through years of specializing in the manufacturing of farm machinery. This Manual is designed to provide you with important information regarding safety, maintenance, and machine operation so you can and will get the best possible performance from your 6140 Grinder Mixer.

Even if you are an experienced operator of this or similar equipment, we ask that you **read this manual before operating the 6140 Grinder Mixer.** The way you operate, adjust, and maintain this unit will have much to do with its successful performance. Any further questions you may have about this product of Art's-Way equipment should be directed to your local Art's-Way dealer or to Art's-Way Manufacturing Co., Inc., Armstrong, Iowa, 50514, (712) 864-3131.

SPECIFICATIONS AND DESIGN ARE SUBJECT TO CHANGE WITHOUT NOTICE

Art's-Way Manufacturing Co., Inc. is continually making product improvements. In doing so, we reserve the right to make changes and/or add improvements to our products without obligation for the equipment previously sold.

Modifications to this 6140 Grinder Mixer may affect the performance, function, and safety of its operation. Therefore, no modifications are to be made without the written permission of Art's-Way Manufacturing Co., Inc. Any modification made without the written permission of Art's-Way Mfg. Co. shall void the warranty of this product.

In the interest of continued safe operation of this 6140 Grinder Mixer, pay particular attention to the safety alert symbol(s) throughout this Manual.

ART'S-WAY MANUFACTURING CO., INC. STATEMENT OF PRODUCT LIABILITY

Art's-Way Manufacturing Co., Inc. recognizes its responsibility to provide customers with a safe and efficient product. Art's-Way Manufacturing Co., attempts to design and manufacture its products in accordance with all accepted engineering practices effective at the date of design. This statement should not be interpreted to mean that our products will protect against the user's own carelessness or failure to follow common safety practices nor will Art's-Way Manufacturing Co., be liable for any such act. In addition, Art's-Way Manufacturing Co. assumes no liability for any altered product or any modified product by users or anyone other than an authorized dealer.

IMPORTANT WARRANTY INFORMATION

The warranty for this 6140 Grinder Mixer appears on page 3 of this Manual. In order to establish proper warranty registration, the Warranty Registration must be completed and returned to the factory. Failure to comply with this requirement may result in reduced warranty allowances.

LIMITATIONS OF THIS MANUAL

This Manual contains operating instructions for your 6140 Grinder Mixer only. Any mention of other machinery in this manual other than the 6140 Grinder Mixer is for reference only. This manual does not replace nor is it to be used for any machinery that may be attached to or used in conjunction with the 6140 Grinder Mixer.

PARTS & SERVICE

As the purchaser of your new 6140 Grinder Mixer, it is very important to consider the following factors:

- A. Original Quality**
- B. Availability of Service Parts**
- C. Availability of Adequate Service Facilities**

Art's-Way Manufacturing Co., Inc. has an excellent dealership network ready to answer any questions you may have about your 6140 Grinder Mixer. Parts for your machine may be ordered through our dealers. When placing a parts order, please have the **model** and **serial number** ready. This will allow the dealer to fill your order as quickly as possible.

For your convenience, we have provided this space for you to record your model number, serial number, and the date of purchase, as well as your dealer's name and address.

Owner's Name: _____

Owner's Address: _____

Purchase Date: _____

Dealership Name: _____

Dealership Address: _____

Dealership Phone No.: _____

6140 Grinder Mixer Serial Number Location

The placard containing the serial and model number is located on the front left-hand side of the 6140 grinder mixer next to ladder. Enter the serial and model number of your 6140 grinder mixer within the space provided.



Figure 1 - Serial Number Placard



Figure 2 - Serial Number Placard

TABLE OF CONTENTS

SPECIFICATIONS AND DESIGN ARE SUBJECT TO CHANGE WITHOUT NOTICE.....		1	TRACTOR HYDRAULIC DISCHARGE AUGER LIFT AND SWING ADJUSTMENT.....	24
ART'S-WAY MANUFACTURING CO., INC. STATEMENT OF PRODUCT LIABILITY		1	DISCHARGE GATE FUNCTION.....	24
IMPORTANT WARRANTY INFORMATION.....		1	TRACTOR HYDRAULIC ACTUATOR CONTROL.....	25
LIMITATIONS OF THIS MANUAL		1	UNLOADING AUGER HOOD.....	26
PARTS & SERVICE.....		2	AUGER FEED OPERATION.....	26
TABLE OF CONTENTS		3	AUGER FEED CONTROLS.....	27
SAFETY FIRST.....		6	GRINDER MIXER ADJUSTMENTS.....	28
NOTICES OF DANGER, WARNING, AND CAUTION		6	DRIVE CHAIN ADJUSTMENTS.....	28
SAFETY GUIDELINES		7	MAIN DRIVE CHAIN	28
BEFORE OPERATING		7	ROLL SPEED DIFFERENTIAL.....	28
DURING OPERATION		7	ROLL GAP.....	28
MAINTENANCE SAFETY		7	ROLL PARALLELISM	29
HYDRAULIC SAFETY		8	ROLL SCRAPERS	29
TRANSPORTATION SAFETY		8	HYDRAULIC SWING ADJUSTMENT	30
STORAGE SAFETY		8	SWIVEL STOP.....	30
TIRE SAFETY		8	SWIVEL STOP ADJUSTMENT.....	30
ASSEMBLY SAFETY.....		8	DISCHARGE AUGER DRIVE ADJUSTMENT.....	30
SAFETY DECALS		10	OPEN AND CLOSED CENTER TRACTOR HYDRAULICS	32
DECAL LOCATIONS & IDENTIFICATION		10	WHEEL BEARINGS	32
INTRODUCTION.....		13	LUBRICATION.....	33
PREPARING THE GRINDER MIXER FOR OPERATION.....		15	PTO DRIVELINE	33
TIRES.....		15	GRAIN CONTROL GATE	33
GUARDS, DOORS, AND SHIELDS		15	ROLL BEARINGS	33
BOLTS AND NUTS		15	ECCENTRIC BEARING HOUSINGS	33
PREPARING THE TRACTOR.....		16	AGITATOR SHAFT BEARINGS.....	34
TRACTOR HITCH		16	ROLLERMILL BELT DRIVE.....	34
ATTACHING TO THE TRACTOR		16	HOPPER MAGNETS	34
ROLLERMILL		17	DRIVE SHAFT BEARINGS	34
BEFORE PROCESSING		17	CHAINS.....	35
DETACHING FROM THE TRACTOR		17	GEARBOX	35
OPERATION OF GRINDER MIXER.....		18	LOWER VERTICAL MIXING AUGER.....	36
TRACTOR PTO ENGAGEMENT		18	UPPER VERTICAL MIXING AUGER	36
PROCESSING		18	DISCHARGE U-JOINT.....	36
PROCESSING		18	DISCHARGE PIVOT PIN	36
ROLLERMILL		18	WHEELS	36
DRIVELINE PROTECTION		18	SERVICE.....	37
HOPPER MAGNETS.....		19	TORQUE SPECIFICATIONS.....	37
GRAIN CONTROL GATE.....		19	SHEAR BOLTS	37
ROLL GAP		19	SPROCKET AND CHAIN ALIGNMENT	37
ROLLERMILL ROLLS.....		20	ROLL REPLACEMENT.....	38
ROLL SELECTION		20	TROUBLESHOOTING GUIDE.....	40
ROLL SPEED DIFFERENTIAL.....		21	HYDRAULICS: INTRODUCTION	42
ROLL SCRAPERS.....		21	HYDRAULICS: PREPARING FOR OPERATION.....	42
PROCESSING WITHOUT MIXING		21	PREPARING THE TRACTOR.....	42
ADDING CONCENTRATE OR SUPPLEMENT.....		21	PREPARING THE GRINDER MIXER	43
FILLING THE MIXER TANK		23	HYDRAULIC COMPONENTS.....	43
SPRING LOADED TANK LID		23	HYDRAULICS: OPERATION.....	44
DISCHARGE AUGER POSITIONING		24	HYDRAULIC SYSTEM PRESSURE RELIEF ADJUSTMENT	44
TRACTOR HYDRAULIC LIFT AND SWING.....		24	HYDRAULICS: ADJUSTMENT/SERVICE & LUBRICATION.....	45

MAIN DRIVE CHAIN	45	POWER REQUIRED.....	49
LUBRICATION	45	SPECIFICATIONS: SELF-CONTAINED	
HYDRAULIC FILTRATION	45	HYDRAULICS	50
FILLER/BREATHER FILTER.....	46	PUMP	50
HYDRAULICS: TROUBLESHOOTING GUIDE	47	HYDRAULIC RESERVOIR	50
ATTACHMENTS	48	FILTERS/STRAINERS/BREATHERS/ INDICATORS.....	50
ELECTRONIC SCALE ATTACHMENT	48	HYDRAULIC MOTORS.....	50
ADJUSTABLE SCALE ARM ATTACHMENT.....	48	MANIFOLD VALVE ASSEMBLY	50
DISCHARGE UNLOADING AUGER EXTENSIONS	48	ELECTRIC ACTUATOR.....	51
SPECIFICATIONS	49	ELECTRIC CONTROL BOX	51
TANK AND FRAME	49	SCHEMATICS: TRACTOR HYDRAULICS	52
DISCHARGE AUGER	49	52
AUGER FEEDER	49	SCHEMATICS: SELF-CONTAINED	
MIXING AUGER.....	49	HYDRAULICS	53
SUPPLEMENT HOPPER.....	49	53
ROLLERMILL	49		

SAFETY FIRST

“A careful operator is the best insurance against an accident”

(National Safety Council)

Most accidents can be prevented if the operator:

- Fully understands how the machine functions
- Can anticipate situations which may produce problems
- Can make necessary corrections before problems develop



**THIS SYMBOL MEANS
ATTENTION!
BECOME ALERT!
YOUR SAFETY IS INVOLVED!**

Figure 3 - Universal Safety Alert Symbol

The American Society of Agricultural Engineers has adopted the Universal Safety Alert Symbol as a way to identify areas of potential danger if the equipment is not operated correctly (See Figure 3). Please be alert whenever you see this symbol in the manuals or on your Grinder Mixer.

Art's-Way Manufacturing Co., Inc. strives to make our equipment as safe as possible. The Art's-Way 6140 Grinder Mixer conforms to applicable safety standards at the time of manufacturing. A safety conscious equipment operator makes an effective accident-prevention program complete.

Safety features and instructions for the Grinder Mixer are detailed in the section of this Operator's Manual. It is the responsibility of the owner to ensure that all operators read and understand the manual before they are allowed to operate the Grinder Mixer. (Occupational Safety and Health Administration (OSHA) regulations 1928.57.)

NOTICES OF DANGER, WARNING, AND CAUTION

Signal Words: Note the use of signal words **DANGER**, **WARNING**, and **CAUTION** on the Grinder Mixer and in this manual. The appropriate signal word for each has been selected using the following guidelines:



DANGER: IMMEDIATE AND SPECIFIC HAZARD WHICH WILL RESULT IN SEVERE PERSONAL INJURY OR DEATH IF PROPER PRECAUTIONS ARE NOT TAKEN.



WARNING: SPECIFIC HAZARD OR UNSAFE PRACTICE COULD RESULT IN SEVERE PERSONAL INJURY OR DEATH IF PROPER PRECAUTIONS ARE NOT TAKEN.



CAUTION: A REMINDER OF GOOD SAFETY PRACTICES. PERSONAL INJURY COULD RESULT IF PROPER PROCEDURES ARE NOT FOLLOWED.



SAFETY GUIDELINES



Remember:

“The Best Operator is a Safe Operator”



CAUTION: READ AND UNDERSTAND THE OPERATOR'S MANUAL AND ALL THE SAFETY DECALS BEFORE OPERATING THE GRINDER MIXER. REVIEW ALL SAFETY INSTRUCTIONS WITH ALL OPERATORS ANNUALLY.

BEFORE OPERATING

- Do not wear loose fitting clothing as it may catch in moving parts.
- Make sure to install and/or secure all guards, doors and shields, including the tractor power take-off (PTO) master shield, before starting or operating the Grinder Mixer.
- Be sure that the correct implement driveline parts are used and that they are properly secured.
- Install the safety chain when attaching the Grinder Mixer to the tractor.
- Clear the area of bystanders, especially children, when making repairs, adjustments or performing maintenance on the Grinder Mixer.
- Do not allow riders.
- Put all tractor and machine controls in “neutral” and disengage the PTO before starting. Follow the starting instructions according to your tractor Manual.
- Operate the Grinder Mixer only while seated on the tractor seat.
- Make sure the unit is adequately supported with safety blocks or safety stands when changing tires or performing maintenance.



CAUTION: KEEP CLEAR OF MOVING PARTS. BE SURE TO SHUT OFF THE TRACTOR AND SET THE PARKING BRAKE. REMOVE THE TRACTOR KEY WHILE MAKING ANY ADJUSTMENTS. WAIT FOR ALL MOVEMENT TO STOP BEFORE APPROACHING THE MACHINE.

DURING OPERATION

- Keep hands, feet, hair, and clothing away from moving parts.
- Keep all guards, doors and shields in place and in good working condition.

- Keep all bystanders, especially children, away from the grinder mixer while in operation.
- Do not allow riders while the grinder mixer is in operation.
- Do not attempt to unclog, clean, or adjust the grinder mixer while it is running.
- Stay away from overhead power lines. Electrocutation can occur even without direct contact.
- Keep all hydraulic lines, fittings, and couplers tight and free of leaks. (Refer to - Hydraulic Safety.)
- Use caution when ascending or descending on the grinder mixer. Wet shoes or boots are slippery.

MAINTENANCE SAFETY

- Follow all operating, maintenance and safety instructions found in this Manual.
- Before servicing, adjusting, repairing or unclogging the machine, always make sure the tractor engine is stopped, the parking brake is set, and all the moving parts have stopped.
- Use sufficient tools, jacks, and hoists that have the capacity for the job.
- Use support blocks or safety stands when changing tires or performing maintenance.
- Follow good shop practices of keeping the service area clean and dry and use adequate light for the job at hand.
- Before applying pressure to the hydraulic system, make sure all lines, fittings and couplers are tightly secured and in good condition.
- Make sure all guards, doors and shields are in place and properly secured when performing maintenance.

HYDRAULIC SAFETY

- Make sure components in the hydraulic system are kept clean and in good working condition.
- Relieve pressure from the hydraulic system before servicing or disconnecting from the tractor.
- Keep all hydraulic lines, fittings, and couplers tightly secured and free of leaks.
- Replace any worn, cut, abraded, flattened or crimped hoses.
- Do not make any temporary repairs to the hydraulic lines, fittings or hoses using tape, clamps, or cement. The hydraulic system operates under extremely high pressure and temporary repairs may fail suddenly and create a hazardous and or dangerous situation.
- Wear proper hand and eye protection when searching for a high-pressure hydraulic leak. Use a piece of wood or cardboard as a backstop instead of hands to identify and isolate a leak. If injured by a concentrated high-pressure stream of hydraulic fluid, seek medical attention immediately. Serious infection or toxic reaction can develop if hydraulic fluid penetrates the surface of the skin.
- Before applying pressure to the system, make sure all components are tight and that the hydraulic lines, hoses, and couplings are not damaged.

TRANSPORTATION SAFETY

- Make sure the grinder mixer complies with all local regulations regarding the transportation of equipment on public roads and highways.
- Make sure the Slow Moving Vehicle (SMV) emblem and all lights and reflectors required by local highway and transportation authorities are properly in place, clean, and clearly visible to traffic.
- Do not allow riders on any machinery during transport.
- Make sure the grinder mixer is securely attached to the tractor and install a safety chain to the grinder mixer.
- Make sure the tractor brake pedals are latched together.
- Do not exceed 20 mph (32 km/h) when transporting the grinder mixer. Always reduce speed on rough roads and surfaces, or when going down inclines.
- Use caution when turning and always use the turn signals on the tractor to indicate your turning intentions to the other traffic.

- The weight of the trailed machine should NEVER exceed the weight of the towing vehicle.
- Check all clearances carefully whenever the machine is towed.
- Lower the elevator into the transport position before transporting the harvester on the highway.
- Stay away from overhead obstructions and power lines during transport. Electrocutation can occur even without direct contact.

STORAGE SAFETY

- Store the grinder mixer in an area away from human activity.
- Do not permit children to play on or around the stored machine at any time.
- Make sure that the grinder mixer is stored in an area with a firm and level base to prevent the machine from tipping or sinking into the ground.
- Block the wheels to prevent the machine from rolling.

TIRE SAFETY

- Have only a qualified tire dealer or tire repair service perform tire repairs.
- Do not attempt to install a tire on a wheel or rim unless you have the proper equipment and experience to do the job.
- Follow proper procedures when installing a tire on a wheel or rim to prevent an explosion that could result in serious injury.
- Do not substitute tires with a lesser road rating and/or capacity for the original equipment tires.



CAUTION: FAILURE TO FOLLOW PROPER PROCEDURES WHEN INSTALLING A TIRE ON A WHEEL OR RIM CAN PRODUCE AN EXPLOSION THAT MAY RESULT IN SERIOUS INJURY OR DEATH. DO NOT ATTEMPT TO INSTALL A TIRE UNLESS YOU HAVE THE PROPER EQUIPMENT AND EXPERIENCE TO PERFORM THE JOB. REPLACEMENT, REPAIR, AND/OR MAINTENANCE SHOULD BE DONE BY A QUALIFIED TIRE DEALER OR QUALIFIED REPAIR SERVICE.

ASSEMBLY SAFETY

- Use adequate manpower to perform assembly procedures safely.
- Assemble the grinder mixer in an area with sufficient space to maneuver the largest

components and allow easy access to all sides of the machine.

- Use only forklifts, lift cranes, jacks and tools with sufficient capacity for the loads.
- Do not allow spectators, especially children, in the working area.

Remember:

“The Best Operator is a Safe Operator”

SAFETY DECALS

DECAL LOCATIONS & IDENTIFICATION

The different types of safety decals for your 6140 Grinder Mixer are illustrated on the following pages. Please familiarize yourself with the appearance of each decal, the warning it describes, and the area where it is located on the grinder mixer (See Figure 4 and **Error! Reference source not found.** and Figure 5).

Safety awareness is the responsibility of each operator of the grinder mixer. Keep safety decals and signs clean and legible and be sure replacement parts display the current safety decals and signs as well.

Remember: Always replace missing, damaged or illegible safety decals. New decals and signs are available from an authorized dealer.

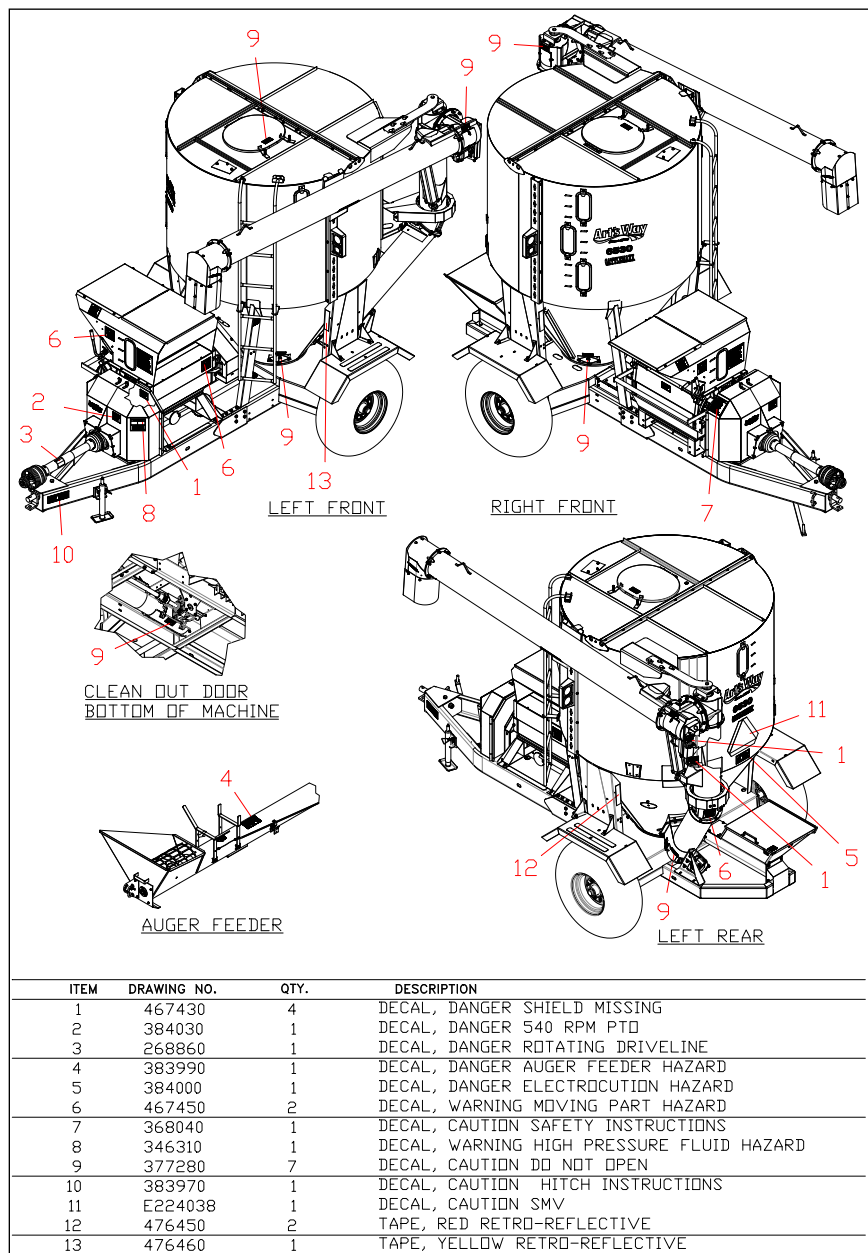

Figure 4 – Safety Decal Locations.

NOTE: Keep all decals clean and free of dirt for maximum visibility. Replace all individual decals that are no longer legible. Read and obey all safety decals and be familiar with their meaning.



1. DANGER - 540 RPM PTO (384030)



2. DANGER - Shield Missing (467430)



3. DANGER – Rotating Driveline (268860)



4. DANGER – Auger Feeder Hazard (383990)



5. DANGER – Electrocutation Hazard (384000)



6. WARNING – Moving Part Hazard (467450)



7. WARNING –High Pressure Fluid Hazard (346310)



8. CAUTION – Safety Instructions (368040)



9. CAUTION – Do Not Open (37728)

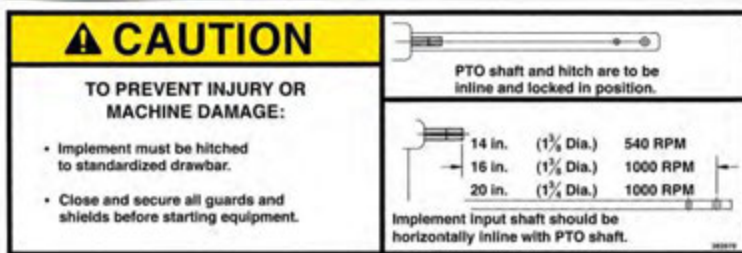

10. CAUTION – Hitch Instructions (383970)

Figure 5 - Safety Decals

NOTE: Keep all decals clean and free of dirt for maximum visibility. Replace all individual decals that are no longer legible. Read and obey all safety decals and be familiar with their meaning.



Figure 6 - Model 6140 CattleMaxx With Auger Feeder (A – PTO Driveline; B – Roller mill and Hopper; C – Mixing Tank; D – Supplemental Hopper; E – Discharge Auger; F – Viewing Windows; G – Ladder; H - Auger Feeder).

INTRODUCTION

This manual has been prepared to make you familiar with the proper operation, adjustment, lubrication and service of your grinder mixer. Take time to be careful and better understand the efficient operation and care of your machine.

Whenever the terms “*Left*” and “*Right*” are used, it should be understood to mean standing behind the machine and facing the direction of forward travel.

Some pictorials are used to show guards, doors and shields removed for easy identification. Make sure that all guards, doors and shields are in place before operating the machine. They are for your protection.

The Art’s-Way 6140 Cattlemaxx is driven by a PTO driveline of 40-130 HP tractors and is factory available with a 540 RPM drive.

Always operate at full speed while rolling grain.



CAUTION: NEVER OPERATE A 540 RPM PROCESSOR WITH A 1000 RPM TRACTOR.

The roller mill is precision built of tough, cast-iron construction, designed to give a high degree of control over the quality of feed produced.

It is important that you become acquainted with your roller mill before operating at full capacity. The

roller mill will NOT start with grain between the rolls.

If supplement is to be added to the ration, a hopper with a sack cutter is located at the right rear of the mixing tank. (**Error! Reference source not found.**6, Detail D – Supplement Auger.) The best mixing will result if the supplement is added before grinding.

The ground feed is mixed continuously until the tractor PTO is disengaged.

The unloading auger pivots at the left rear of the mixing tank and can swing 180 degrees on the grinder mixer in a horizontal arc. (**Error! Reference source not found.**6, Detail E) It can also swing in a vertical arc to the limit of the lift cylinder. Unloading rates up to 30 bushels per minute can be obtained depending upon position of the discharge and the type of material processed.

Five viewing windows are located at the front right corner of the mixing tank to observe the feed level during grinding and mixing. (**Error! Reference source not found.**6, Detail F.)

A ladder is located at the front left corner of the mixing tank to gain access to the spring-loaded mixing tank lid.



CAUTION: DO NOT OPEN SPRING-LOADED MIXING TANK LID WHILE PTO

IS ENGAGED AND TRACTOR IS RUNNING.

Many convenient features are standard equipment on the Art's Way 6140 grinder mixer including:

6140 Cattlemaxx

1. Heavy-duty 540 RPM implement driveline with shear clutch.
2. 13.5 x 16.1 tires.
3. 20 inch heavy-duty rollermill.
4. Roll scrapers.
5. Rollermill hopper magnetic system.
6. Feed inspection tube under rollermill.
7. Hydraulic positioning of discharge auger. This includes a hydraulic cylinder for lift and hydraulic motor for swing.
8. Fenders.
9. Tongue jack.
10. Discharge auger hood with spring loaded relief door.
11. Tractor run hydraulics and self-contained hydraulics with electric actuated discharge opening.
12. Highway transport light kit.

Below is a list of optional attachments available:

1. Auger feeder (hydraulic).
2. Electronic scale, with digital readout.
3. Positioning arm for electronic scale box.
4. Unloading auger extensions; 3 ft. or 6 ft. Bolt-on.
5. Roll speed differential drive rollermill.

PREPARING THE GRINDER MIXER FOR OPERATION

Remove the shipping banding or wire from the auger feeder (if equipped), rear discharge cover and the unloading tube to saddle at the side of the tank.

IMPORTANT: Remove the bag from the supplement hopper. A wrench is provided for adjusting the roll gap spacing of the roller mill. Keep this wrench with the mill at all times

Install the PTO driveline storage bracket under the front hitch with 1/2 inch x 1-1/2 inch bolt and lock nut (See Figure 7). Maintain tension with the lock nut to allow movement with 15 lbs. pull.



Figure 7 - PTO Driveline Storage Bracket.

If equipped with auger feeder, refer to OPERATION OF GRINDER MIXER – Auger Feeder Operation.

Install any option that was ordered with the grinder mixer and shipped as loose equipment. See instructions packaged with the specific options for installation.

Install the implement end of the PTO driveline by fastening it to the input shaft with the 5/16 inch x 3-1/2 inch clevis pin and cotter pin provided.

Spread the cotter pin and make sure the proper PTO is used.



CAUTION: NEVER OPERATE A 540 RPM GRINDER MIXER WITH A 1000 RPM TRACTOR.

NOTE: Height of the unloading auger tube needs to be checked. Move the saddle on the side of the mixing tank so the tube will properly clear the tractor and cab.

If equipped with a bolt-on extension, hydraulic auger feeder, refer to OPERATION OF GRINDER MIXER –Unloading Auger Hood and Auger Feed Operation sections as well as the ATTACHMENTS section for instructions.

TIRES

Keep tires properly inflated. Lack of pressure can result in torn valve stems, fabric breaks and uneven tread wear. Too much pressure can cause undue strain on fabric, excessive tread wear and allows the tire to cut in more on wet surfaces. Equal tire pressure reduces grinder mixer sway when towing.

Recommended tire inflation pressure is as follows:

13.5 x 16.1 8 – PR tires – 28 psi

GUARDS, DOORS, AND SHIELDS

Make sure that all of the guards, doors, and shields are in place and functioning.

BOLTS AND NUTS

Cap screws, except for shear bolts, used on the grinder mixer are Grade 5 and if replaced, cap screws of equal or greater strength should be used. Grade 5 cap screws are identified by three radial dashes on the hex head. Refer to the SAE bolt identification guide (See Figure 8).

IDENTIFICATION OF SAE BOLT GRADES; HEAD MAKINGS	
Grades 0, 1, and 2 no markings	
Grades 5: 3 radial dashes 120° apart	
Grades 8: 6 radial dashes 60° apart	

Figure 8 - SAE Bolt Identification.

IMPORTANT: Shear bolts must be replaced with bolts of the same grade

Before operation of the grinder mixer, make sure all bolts and nuts are properly tightened. Make sure all cotter pins are spread and not damaged. After operation of the grinder mixer for several hours, make sure all bolts are set to proper torque. Refer to the torque guide (See Table 1).

Size	Clamp Load	Plain GR 5	Plated GR 5
1/4 – 20 (.250)	2,025	8 ft. lbs.	76 in. lbs.
5/16 – 18 (.3125)	3,338	17 ft. lbs.	13 ft. lbs.
3/8 – 16 (.375)	4,950	31 ft. lbs.	23 ft. lbs.
7/16 – 14 (.4375)	6,788	50 ft. lbs.	37 ft. lbs.

1/2 – 13 (.500)	9,075	76 ft. lbs.	57 ft. lbs.
9/16 – 12 (.5625)	11,625	109 ft. lbs.	82 ft. lbs.
9/16-18 (wheel bolt)	12,950	NA	70-80ft. lbs
5/8 – 11 (.625)	14,400	150 ft. lbs.	112 ft. lbs.
3/4 - 10 (.750)	21,300	266 ft. lbs.	200 ft. lbs.
7/8 – 9 (.875)	29,475	430 ft. lbs.	322 ft. lbs.
1 – 8 (1.00)	38,625	644 ft. lbs.	483 ft. lbs.
1-1/8 – 7 (1.125)	42,375	794 ft. lbs.	596 ft. lbs.

Table 1 - Torque Specification Guide for Grade 5 Bolts.

Lubricate the grinder mixer at regular intervals as instructed in the lubrication sections. (Refer to **LUBRICATION** section.)

PREPARING THE TRACTOR

The tractor must be equipped with a 540 RPM PTO to match the grinder mixer as described in the previous section. Make sure the grinder mixer and the tractor are equipped and set for the proper RPM.



CAUTION: NEVER OPERATE A 540 RPM GRINDER MIXER WITH A 1000 RPM TRACTOR PTO.

TRACTOR HITCH

The hitch for the grinder mixer is designed to attach to any SAE – ASAE standardized tractor drawbar. Adjust the drawbar so it is 13 to 17 inches above the ground (See Figure 9). Extend or shorten the tractor drawbar so the horizontal distance from the end of the tractor PTO shaft to the center of the hitch pin hole is 14 inches for 540 RPM.

Lock the drawbar in its crossbar, parallel with the centerline of the PTO. Place locking pins on each side of the drawbar. If the tractor has an offset drawbar, the offset should be down for PTO work.

IMPORTANT: An improperly located hitch point may cause damage to the universal joints (U-Joints) of the PTO driveline.

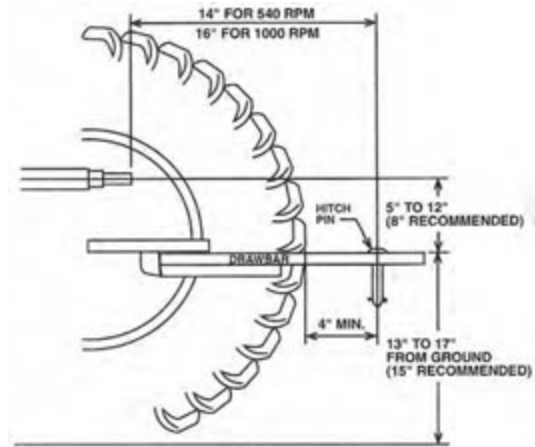

Figure 9 - Hitch Point Locations

ATTACHING TO THE TRACTOR

NOTE: Height of the unloading auger tube needs to be checked. Move the saddle on the side of the mixing tank so the tube will properly clear the tractor and cab.

Carefully back the tractor up to the hitch. Use the crank of the jack to raise or lower the grinder mixer hitch into position to engage the tractor drawbar.

Fasten the grinder mixer hitch to the drawbar with a hitch pin that cannot bounce out. Raise the jack and lock into the transport position (See Figure 10). Attach the safety chain from the grinder mixer to the tractor (See Figure 11).



CAUTION: ALWAYS FOLLOW STATE AND LOCAL REGULATIONS REGARDING A SAFETY CHAIN WHEN TOWING FARM EQUIPMENT ON PUBLIC HIGHWAYS.



Figure 10 - Jack in Transport Position



Figure 11 - Grinder Attached To The Tractor With Safety Chain.

For Electronic Scale Indicator, plug the scale power supply cord into the electrical outlet on the tractor or to the battery on the mixer frame. (Wire power cord to the battery as shown in Figure 27)

IMPORTANT: On electronic scale applications, if a bolt and nut are used in place of a hitch pin, the nut must not be tightened to where it hits against the underside of the weigh bar clevis.

Connect the PTO driveline to the tractor PTO shaft. The PTO operating speed of the tractor and grinder mixer must be the same. The tractor half of the PTO is equipped with 6-splines for 540 RPM operation.

Plug 7-Pin connector for lights into tractor receptacle.

ROLLERMILL

Check that the rollermill feed control gate is closed and remove any debris on top of the gate. The rollermill will not start if there is any material or debris in the rolls (See Figure 52).

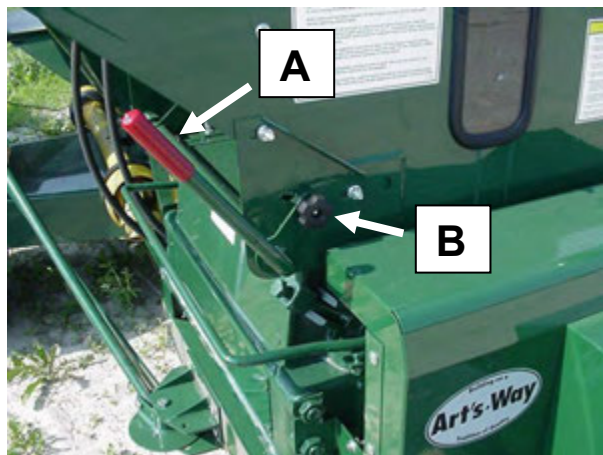

Figure 52 - Rollermill in Closed Position (A - Gate Lever; B - Gate locking Knob).

BEFORE PROCESSING

New machines should be operated before preparing feed. A few hundred pounds of coarse material such as shelled corn or ground cobs should be ran through the grinder mixer. This will remove the protective oil coating from the mixer

cone and any metal particles that may be in the machine. This will help polish the cone and prevent bridging. After several minutes of running the grinder mixer, unload the mixture and discard. **Do not feed this mixture to the livestock.**

DETACHING FROM THE TRACTOR



CAUTION: MAKE SURE THE TRACTOR IS SHUT OFF, REMOVE THE KEY AND PLACE THE KEY IN YOUR POCKET.

IMPORTANT: Make sure the discharge auger and the auger feeder are in their saddles before disconnecting.

Disconnect the PTO driveline and front shield anchor chain from the tractor and place it on the PTO driveline support bracket (See Figure 3). The PTO driveline support should be tight enough to remain in position when rotated from storage against the frame to use position.

Disconnect the electronic scale power cord, control box power cord, and/or actuator control box power cord from the tractor (if equipped).

Disconnect the hydraulic hoses from the tractor outlets.

Disconnect 7-Pin connector for lights from tractor and plug into storage receptacle on grinder mixer frame.

Block the tires. Lower the jack stand to the ground. Turn the handle of the jack stand to raise the grinder mixer tongue off of the tractor hitch. Remove the hitch pin and safety chain.



Figure 13 - PTO Support.

OPERATION OF GRINDER MIXER

TRACTOR PTO ENGAGEMENT

The mixer may be operated by engaging the PTO. Always engage the tractor PTO with the tractor engine at idle speed. After the PTO is engaged, increase the engine speed gradually until the advertised operating PTO speed is obtained. Reverse the PTO engagement steps to disengage the PTO.

PROCESSING

To grind any material without mixing, engage the unloading auger lever, open the tank unloading auger door and start the grinding operation.

The feed will be augered into the mixing tank cone and then out through the unloading augers without mixing. Position the unloading auger tube as needed to direct the feed.

PROCESSING

A rollermill processor is designed to process grains without the fines and deviations in particle size experienced with hammermills. However, a rollermill is limited in capacity compared to a hammermill in that the rate of feed processing is restricted by the roll gap and roll selection, and more horsepower will not increase capacity of the mill. It is important that you become familiar with the rollermill before operating it at full capacity.

All projected particle sizes will vary depending on the quality and moisture content of the grain, roll gap, power input, roll speed differential drive, and the general operation of the mill.

Always operate the rollermill at full speed (540 RPM) when processing. Slower speeds will increase power requirements and may cause damage or excessive wear to mill components.

ROLLERMILL

The rollermill drive is a direct drive without a drive clutch, so the rolls will turn at all times. The drive consists of a direct driven drive roll, which drives the eccentric (Adjustable) roll and hopper agitator shaft through a rear belt drive. Always start and stop the CattleMaxx at low speeds so as not to damage any drive components.

To operate the rollermill, engage the tractor PTO at a low RPM and increase speed to the full rated 540 RPM. Start to fill the hopper with grain, allowing the full width of the hopper to fill to just above the magnet before operating the grain control gate. Open the grain control gate to the desired opening and lock the knob (See Figure 4). When processing

For smooth PTO operation and to help increase the life of the PTO driveline, make sure the tractor is aligned straight with the frame of the grinder mixer whenever possible.

IMPORTANT: If mixing while in transport, avoid sharp and unnecessary turns which may damage the PTO driveline.

is complete, allow the hopper to empty completely and close the grain control gate fully, locking the knob to keep the gate closed. Stop the rollermill and disengage the PTO at a low RPM only after the grain control gate has been closed and all grain in the rollermill has been processed.

IMPORTANT: Never stop the rollermill with grain in the rolls. The rollermill will not start if any grain is wedged in the apex of the rolls.

The rollermill will not start if there is any material between the rolls. If material does get into the rolls without the PTO engaged, the roll gap must be opened or the material cleaned from the rolls before the rolls can be turned.

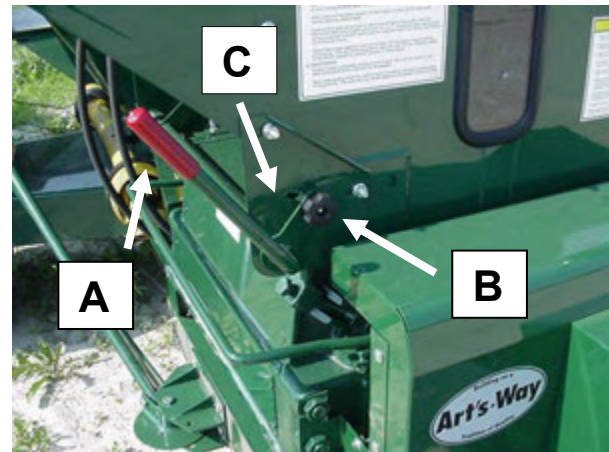

Figure 14 - Grain Control Gate Operation (A - Gate Lever; B - Gate Locking Knob; C - Lever Gauge).

DRIVELINE PROTECTION

The CattleMaxx driveline is protected from overloading by a shear clutch located at the end of the PTO driveline on the drive roll (See Figure 5). Always replace the shear clutch bolt with a metric M10-1.5 x 60 bolt. Use of any other type or size of

shear bolt will compromise the driveline protection of the machine.



Figure 15 - PTO Driveline Shear Clutch

HOPPER MAGNETS

Two plate magnets are located in the hopper above the rollermill (See Figure 66). Always load the hopper from the right-hand side to utilize these magnets. A magnet assembly is also located in the hopper throat just above the rollermill rolls. This is standard equipment on all machines to help protect the mill from tramp metal. It is important to keep the magnets clean and monitor their condition.

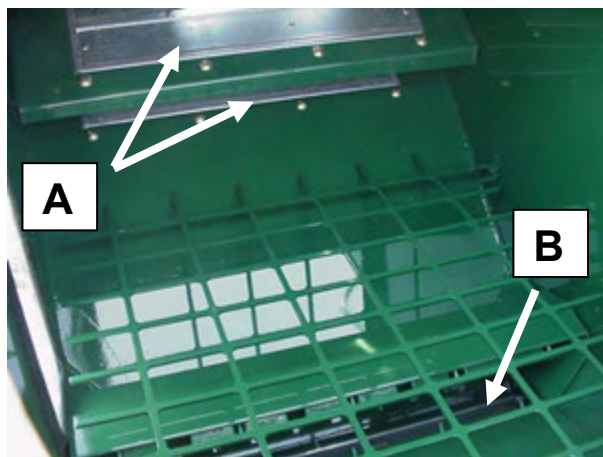

Figure 66 - Plate Magnet in Hopper (A - Plate Magnets; B - Throat Magnet).

GRAIN CONTROL GATE

The grain control gate is used to regulate the flow of grain into the rollermill. The grain control gate lever is located at the front right corner of the mill (See Figure 7). To adjust the grain control gate, loosen the knob and push or pull the lever to close or open the gate. Each slot on the grain control gate lever gage is approximately 0.25 inch of gate opening. Tighten the knob to hold the gate in place once the desired opening is set.

Open the grain control gate after the rollermill has been started and the hopper as about half full (grain showing in the hopper inspection window). Open the control gate enough to allow a smooth grain flow into the rollermill. Recommended control gate opening is 0.5 inch to 1.0 inch. A high grain flow rate will cause grain to boil on top of the rolls and decrease capacity of the rollermill.

IMPORTANT: The grain control gate should be opened only enough to provide the rate of processing required, with a maximum gate opening of 1.0 inch.

Opening the grain control gate more than 1.0 inch will overload the mill and cause mill vibrations, and also result in lower capacity, larger grain particle size, undo drive stress, shortened roll life, and excessive power requirements. When the CattleMaxx is operated for the first time, the feed rate from the auger feeder or bin should be restricted until you become acquainted with the capacity of the unit.

Always ensure that the grain control gate is closed during transport or when not in use. This will prevent material from falling into the apex of the rolls and preventing the rollermill from starting.

ROLL GAP

Roll gap is the space between the rollermills rolls, which is used to control the particle size of the rolled feed. A roll gap of 0.010 inch is set at the factory and should never be set less than 0.008 inch. This setting is determined by the adjustment of the eccentric roll handle stops (See Figure 7). Use this minimum setting for fine processing and open the roll gap for coarser processing. Use the pointer on the front bearing housing of the eccentric roll for wider roll gap setting reference.

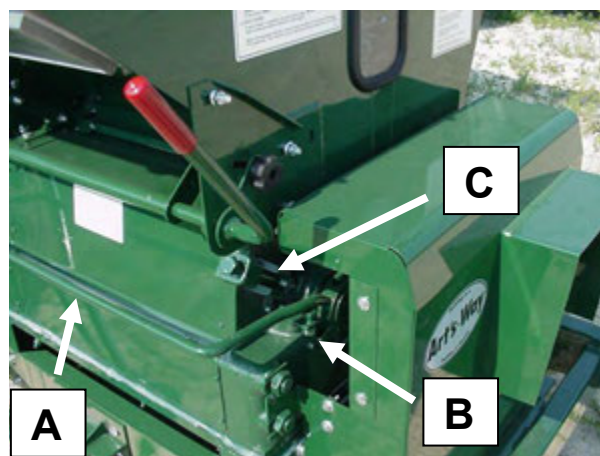

Figure 17 - Eccentric Roll Settings (A - Eccentric Handle; B - Eccentric Handle Stops; C - Eccentric Roll Lock Bolt).

The minimum roll gap on the rollermill must be maintained to ensure a consistent particle size. This

should be monitored as the rolls wear and will also need to be adjusted for any replacement or re-grooved rolls.

Roll gap should be set for each type of grain. It is not recommended to process mixed grains as greater particle size deviation will occur. You are encouraged to experiment with the roll gap setting to meet the requirements of rolling different grains in your operation. Particle size can be monitored by using the grain inspection trough under the left-hand side of the rollermill to take feed samples (See Figure 8).



Figure 18 - Grain Inspection Trough.

Be careful not to over roll grains with too small of a roll gap setting on the rollermill. Over rolling takes more power, reduces capacity, and causes unnecessary roll wear. The rollermill should be ordered with the rolls grooved for the smallest grains to be rolled.

Be careful when adjusting the roll gap to always pull on the eccentric roll handle evenly, either from both ends or from the center. Do not pull up on the eccentric roll handle from only one end, as twisting or bending the handle will move one of the eccentric roll more than the other and cause the rolls to become out of parallel with each other. Parallel rolls must be maintained to achieve uniformity in the feed particle size.



CAUTION: NEVER ADJUST THE ROLL GAP WHILE THE CATTLEMAXX IS RUNNING.

The rollermill is equipped with a positive pressure eccentric roll release to automatically open the gap between the rolls. This is to minimize damage to the rolls and drive train from the induction of tramp metal or other foreign objects into the rolls. Opening the grain control gate too far and overloading the rolls can also cause the eccentric roll release to trip. Indications that the eccentric roll release has been tripped are a sudden higher particle size in the processed feed and the eccentric roll handle has

moved up. The eccentric roll release must be reset if this occurs.

The eccentric roll release is set by tightening the eccentric lock bolts after the eccentric roll handle has been positioned for desired roll gap. The lock bolts tighten down on a brass plug, which pushes against a knurled surface on the eccentric roll bearing housing. Excessive pressure between the roll will shear the brass plug and open the roll gap.

Do not over-tighten the eccentric lock bolts, as this will render the eccentric roll release ineffective. Tighten the eccentric lock bolts only until they are snug. Use only the wrench provided to tighten the eccentric lock bolts so as not to over torque the bolts.

ROLLERMILL ROLLS

The rollermill rolls in the CattleMaxx are made of heat treated cast iron. The rate of wear on the roll is dependent upon the hardness or abrasiveness of the grain, the amount of overloading done, and damage resulting from foreign objects such as tramp metal, stones, etc. Increase in particle size and horsepower requirements are signs of increased roll wear. Rolls should be replaced when they become worn down and the surface is slick and shiny.

Worn rolls can be re-grooved and re-heat treated by Art's-Way. Refer to the "Service" section of this manual for information on replacement rolls.

ROLL SELECTION

Rollermill rolls can be purchased with either a sharp or flat groove cut. The sharp groove rolls offer a higher capacity and finer particle size while the flat groove rolls are for flaking or cracking grains.

Rollermill rolls can be cut with 5, 7, or 10 grooves per inch. The 10 groove roll will take any small grain and is recommended for wheat, milo, barley, oats, etc. The 7 groove roll will also take these small grains as well as shell corn, however the smaller kernels may pass through the rolls uncracked. It is suggested to use a combination of one 7 and one 10 groove roll when using multiple grains such as corn and milo. The 5 groove roll is recommended for use with shell corn. The courser groove rolls will have a higher capacity than the fine groove rolls (See Table 2).

When using roll combinations with different grooves (sharp to sharp or flat to flat) the coarser grooved roll is the drive roll. When combining sharp and flat rolls with the same number of grooves, the drive roll is the sharp roll.

Capacity of the roller mill is dependent upon the roll selection as well as the roll gap, roll speed

differential, condition of the rollermill, and quality of material.

Rolls	Material	Aprox. Bu./Hr.
10 Groove	Oats	200 to 300
	Wheat/Barley	200 to 300
	Milo/Corn	300 to 400
7 Groove	Milo/Corn (Dry)	350 to 450
	Milo/Corn (Hi	300 to 400
5 Groove	Milo/Corn (Dry)	400 to 600
	Milo/Corn (Hi	350 to 550

Table 2 - Roll Capacity Chart

ROLL SPEED DIFFERENTIAL

Your CattleMaxx rollermill may be equipped with a belt driven roll speed differential. This increases the speed of the eccentric roll, which causes a scrubbing effect on the rolls helping to keep them clean. The CattleMaxx rolls should be equipped with a roll speed differential if high moisture grain is to be used. A roll speed differential has also been found to decrease particle size and increase capacity of the rollermill.

ROLL SCRAPERS

The CattleMaxx rollermill is equipped with roll scrapers to help prevent material from packing onto the rolls. With course or dry material, the spiral design of the roll groove cut keeps the rolls clean and roll scraper setting is not as critical. For fine or high moisture material, a higher tolerance roll scraper setting should be maintained. Allowing material to build up on the rolls will cause a loss of capacity and excess load on the drive components.

Roll scraper setting needs to be monitored as the rolls wear and should be adjusted after changes in a minimum roll gap setting or when replacing rolls. The main drive roll scraper should be set at 0.006 inch clearance and the eccentric roll scraper should be set at 0.050 inch clearance.

PROCESSING WITHOUT MIXING

To process any material without mixing, engage the unloading auger lever, open the tank unloading auger door and start the processing operation.

The feed will be augered into the mixing tank cone and then out through the unloading augers without mixing. Position the unloading auger tube as needed to direct the feed.

ADDING CONCENTRATE OR SUPPLEMENT

Concentrate or supplement should be added to the ground feed through the supplement hopper located at the right rear corner of the CattleMaxx (See **Error! Reference source not found.**9). A serrated sack cutter is located in the hopper opening. A grate is positioned below the sack cutter to keep the bag from falling into the auger.



CAUTION: KEEP HANDS AND FEET CLEAR OF AUGER. MAKE SURE GRATE IS ALWAYS IN PLACE.

Note: For best results, add the concentrate or supplement before grinding operation. Do not add ingredients to the supplement hopper while grinding, this will over load the auger.



Figure 19 - Supplement Hopper Located on Center Rear Right Hand Side of Machine.

If micro-ingredients are to be added to the feed, the best results are obtained with a pre-mix, or by adding the supplements and micro-ingredients at the same time. If the micro-ingredients are desired without a pre-mix or other supplement, open the mixing tank lid and add the ingredients directly into the mixer. This should be done at the beginning of the operation. Make sure to close the lid before starting the operation. The supplement hopper lid should always be closed when not in use. If strong additives are not desired in the batch that follows, clean out the tank cone and unloading augers through the clean-out doors (See Figure 0).



CAUTION: MAKE SURE THE PTO IS DISENGAGED AND THE TRACTOR IS SHUT OFF. PLACE THE KEY IN YOUR POCKET BEFORE OPENING OR CLOSING THE CLEAN-OUT DOOR.



Figure 20 - Cleanout Door (A) Located Under Right Hand Side Of Tank Assembly.

Located under the right hand side frame and tank assembly is a hinged door on the bottom of the auger trough. Release two spring clamps and allow door to drop. Keep away from the opening. Run the mixer slowly until the trough and the mixing tank are cleaned out. Keep all bystanders away from the machine.

140 BU. – APPROXIMATE CAPACITY CALIBRATION – IN POUNDS*

Actual weights may vary due to material, moisture, and roll configuration. Ration weight is not included and is variable.

Window Position	Ground Oats 22.5 lbs/bu	Ground Barley 36 lbs/bu	Ground Milo 56 lbs/bu	Ground Shelled Corn 50 lbs/bu	Ground Ear Corn 38 lbs/bu	Un-ground Shelled Corn 56 lbs/bu
Full	3210	5137	7990	7134	5421	7990
9	3020	4833	7518	6712	5101	7518
8	3806	4490	6984	6236	4740	6984
7	3590	4145	6447	5756	4375	6447
6	2351	3765	5856	5229	3975	5856
5	2149	3437	5347	4774	3629	5347
4	1944	3110	4838	4320	3283	4838
3	1687	2700	4200	3750	2850	4200
2	1482	2372	3691	3295	2505	3691
1	1278	2045	3182	2841	2159	3182

NOTE: * Above weights are approximate and are to be used as a guide only. Variations may occur due to test weight of grain, slope of machine, moisture content, or roll configuration. For best ration control use an electronic scale.

Table 2 - Approximate Calibration Capacity.

FILLING THE MIXER TANK

Make sure the mixing tank unloading door is closed. As the mixing tank is filling, watch the ground feed through the mixing tank windows. If the top window is covered, this does not mean the tank is full as the mixing auger throws material away from the center of the tank. Continue loading until the top window clears (feed drops) and then becomes covered again about half-way (See Figure 71). Stop feeding material into the processor at this point, but continue operating until the processor has had time to clear. *Do not overload the mixer.* An overload can cause damage to the machine. To estimate the number of bushels that are in the tank, refer to Table 2.

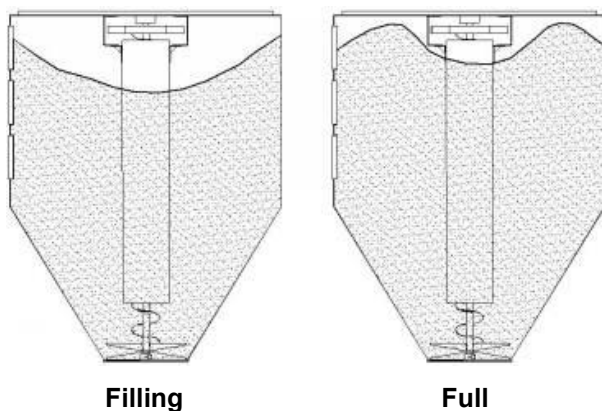

Figure 71 - Filling Pattern.

For the best mixing results, always add lightweight bulky materials first. Always add high moisture corn or grain last. Excessive amounts of wet or bulky material may cause *bridging* in the mixing tank.

SPRING LOADED TANK LID

CAUTION: DISENGAGE ALL THE DRIVES. SHUT OFF THE TRACTOR ENGINE AND PLACE THE KEY IN YOUR POCKET BEFORE OPENING THE MIXING TANK LID.

If the mixing tank is accidentally overfilled, it is equipped with a spring loaded tank lid (See Figure 2). The lid also allows access to the inside of the mixing tank. Keep the lid closed and latched at all times.

CAUTION: IF ENTERING THE TANK, MAKE SURE THE TRACTOR ENGINE IS SHUT OFF. PLACE THE KEY IN YOUR POCKET AND DISCONNECT THE PTO DRIVELINE.



Figure 22 - Spring Loaded Tank Lid.

After the processing is completed and the desired ration is in the mixing tank, allow the mixer to operate until it is ready to unload. Run the mixer 2 to 3 minutes to ensure the feed and supplements have been thoroughly mixed.

IMPORTANT: Avoid sharp and unnecessary turns which may damage the PTO driveline during transport.

DISCHARGE AUGER POSITIONING

After mixing, the finished feed may be unloaded into storage bins, wagons, or feeders. Positioning (lift and swing) and drive of the unloading auger is controlled hydraulically.



Figure 23 - Unloading Auger.

TRACTOR HYDRAULIC LIFT AND SWING

Connect four hydraulic hoses with the appropriate male connectors to the tractor (hoses are marked with different colored zip ties to help with identification). Make sure the proper hoses are connected to the same tractor hydraulic circuit. Activate the appropriate tractor valve to lift the Discharge Auger, and then use the other hydraulic valve to swing the Discharge Auger to the desired position.

Hose Color Markings:

Discharge Cylinder Raise	Red (2X)
Discharge Cylinder Lower	Red (1X)
Discharge Swing Left	Yellow (2X)
Discharge Swing Right	Yellow (1X)

TRACTOR HYDRAULIC DISCHARGE AUGER LIFT AND SWING ADJUSTMENT

Turning the flow control valves adjustment knobs changes the speed at which the lift cylinder raises or lowers the Discharge Auger and the rate at which the Discharge Auger swings left and right. (See Figure 4) for which Flow Control Valve adjusts each function. Turning the knob clockwise restricts flow

and slows the function. Conversely turning the knob counter-clockwise increases flow and speeds up the function.

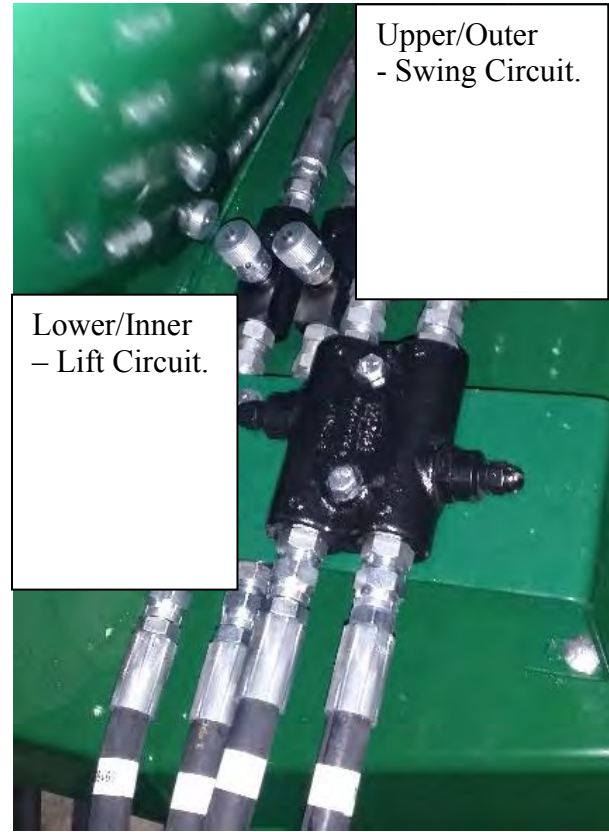

Figure 24 – Tractor Hydraulics Relief and Flow Control Valves.

DISCHARGE GATE FUNCTION

When the discharge auger is in position to unload the tank the gate can be open or closed by an electric actuator (See Figure 85). The actuator is controlled by a Single Toggle Control Box (See Figure 96).

IMPORTANT: Be careful with finer ground feed as it can stall out the Discharge Auger if the gate is open to far.



Figure 85 - Discharge Gate with Electric Actuator in closed position.

TRACTOR HYDRAULIC ACTUATOR CONTROL

Mount the Actuator Control Box (See Figure 96) in the tractor cab or in a convenient location with the supplied parts. Connect the power as shown in Figure 27. Flipping the toggle switch up opens the gate and moving the switch down closes the gate.

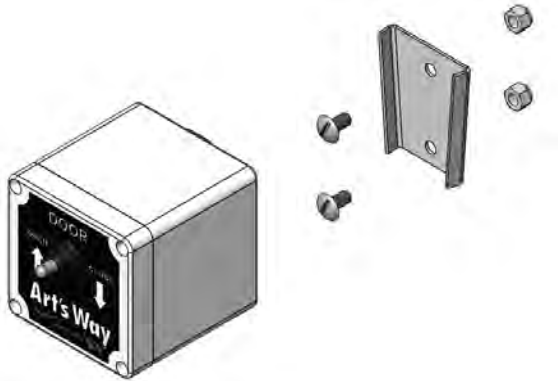

Figure 96 – Tractor Hydraulics Actuator Control Box and Mounting Parts.

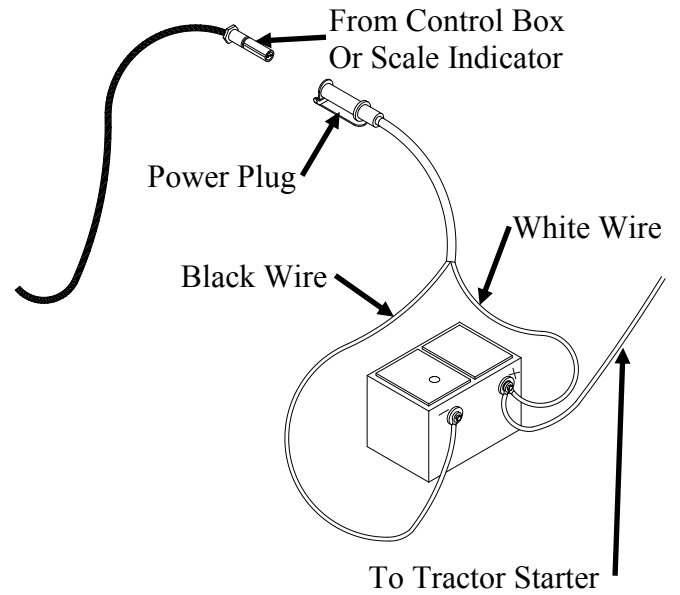

Figure 27 - 12 Volt System.

Unloading Auger Configuration	Discharge at -11° MIN Angle Vertical Height (Approx.)	Discharge at 0° Angle Vertical Height (Approx.)	Discharge at 57° MAX Angle Vertical Height (Approx.)
Standard 10 ft. Long Discharge Tube – No Extensions	6 ft. 0 in.	9 ft. 0 in.	16 ft. 6 in..
3 ft. Auger Extension	5 ft. 6 in.	9 ft. 0 in.	19 ft. 0 in.
6 ft. Auger Extension	5 ft. 0 in.	9 ft 0 in.	21 ft. 6 in.

Table 3 - Unloading Auger Heights.

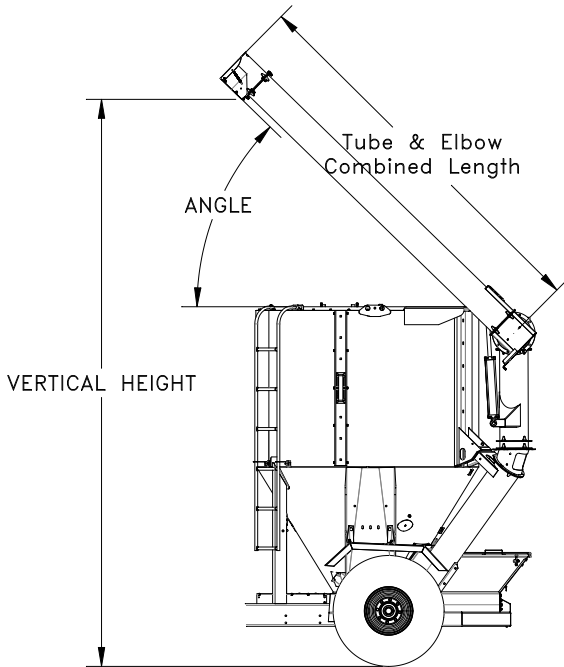

Figure 28 - Unloading Auger Heights (Refer to Table 4 for Detailed Heights.)

UNLOADING AUGER HOOD

When the unloading auger tube becomes overloaded, a spring loaded door opens on the end to prevent damage to the drive (See Figure 29).



Figure 29 - Unloading Auger Hood.

AUGER FEED OPERATION

NOTE: The grinder mixer may be equipped with a hydraulic auger feeder.



Figure 30 - Auger Feeder (Shown in Transport Position).

To position the Auger Feeder, remove the clip pin from the fender bracket and lift the bottom of the Auger Feeder slightly so the brackets can clear the fender. Swing the Auger Feeder outward, away from the tank to ensure it will clear the fender when it is lowered. Lift the Auger Feeder slightly and pull the rope on the right hand side to disengage the height adjustment ratchet bar. Raise or lower to the desired height and release the rope. Remove the clip pin holding the Auger Feeder folding hopper up and then swing the hopper down.

IMPORTANT: Never start the Auger Feeder with folding hopper and grate guard in up position. Failure to do so can cause bodily harm and possibly damage hopper wing.



Figure 31 - Auger Feeder Counter Balance Spring.

When processing material such as ear corn, the grate must be left in the up position. If you must grind with the grate up, use extreme care and make sure to stay clear of the auger.



DANGER: TO PREVENT PERSONAL INJURY:

1. **USE THE GRATE OVER THE AUGER WHENEVER POSSIBLE**
2. **KEEP HANDS AND FEET OUT OF THE HOPPER AREA AND DO NOT CLIMB ON OR OVER THE HOPPER AT ANY TIME.**
3. **KEEP CHILDREN AND BYSTANDERS AWAY FROM THE MACHINE WHILE THE MACHINE IS IN OPERATION**

Make sure the auger feeder emergency shutoff handle, located by hopper, will stop the auger feeder. Loosen the cable clamps to re-adjust if it does not.

The auger feeder swing brake prevents the auger from swinging. Tighten or loosen as desired (See Figure 32).

NOTE: If a more accurate reading is desired and the machine is equipped with an electronic scale, **DO NOT** allow the auger feeder to rest on the ground. Place it in the desired position and set the swing brake (See Figure 2).



Figure 32- Auger Feeder Swing Brake.

The auger feeder is counter balanced by a spring (See Figure 32). If the spring needs adjusted; loosen the nut on the lower bolt, turn the bolt in to increase the spring tension, tighten the nut.

AUGER FEED CONTROLS

Shut-Off handles are provided at the auger feeder hopper and at the flow control valve at the top of the auger feeder housing. To shut off the auger feeder, pull the handle at the hopper area or move the flow control valve to off (See Figure3).



Figure 33 - Hydraulic Auger Feeder Controls (Shown in On).

To start the auger feeder, the flow control handle is moved forward (clockwise, See **Error! Reference source not found.33**). If the hydraulic auger feeder is operated by tractor hydraulics, there must be a minimum of 8 GPM flow and 1500 psi pressure available.

GRINDER MIXER ADJUSTMENTS



CAUTION: DO NOT MAKE ANY ADJUSTMENTS WHILE THE MACHINE IS IN OPERATION AUGER/SUPPLEMENT.

DRIVE CHAIN ADJUSTMENTS

The mill to mixer auger/supplement hopper drive chain is tensioned with a wood block idler (See Figure 34). Adjust the chain tension to 1/2 inch total deflection by positioning the idler sprocket.

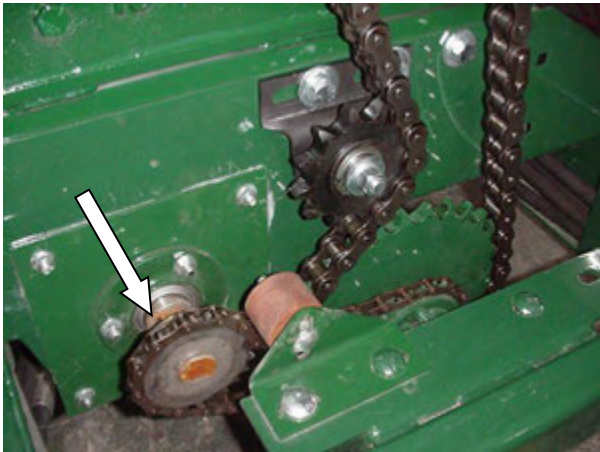

Figure 34 - Mill to Mixer Auger Drive Chain.

MAIN DRIVE CHAIN

Adjust the tension of the main drive chain by loosening the idler roller and bolt, and then sliding the idler sprocket toward the chain. (See **Error! Reference source not found.**34) Re-tighten the idler roller bolt and make sure the chain deflection is 1/2 inch total at the longest span

NOTE: *The chain should be checked and oiled daily.*

ROLL SPEED DIFFERENTIAL

Your CattleMaxx may be equipped with a belt driven roll speed differential that increases the speed of the eccentric roll. Be certain to maintain proper belt tension with stretch loaded idler (See **Error! Reference source not found.**35) as the belts will stretch during their break-in period. Improper tensioning or overloading the mill will cause the belts to slip causing premature wear and reduced belt life.



Figure 35 - Drive Chain Adjustment (Shields Removed For Clarity).

ROLL GAP

The minimum roll gap on the mill must be maintained to ensure a consistent fine particle size. This should be monitored as the rolls wear and also need to be adjusted for any replacement or re-grooved rolls.



DANGER: DO NOT MAKE ANY ADJUSTMENTS WHILE THE CATTLEMAXX IS IN OPERATION.

To open the roll gap, loosen the eccentric lock bolts (See Figure 36) with the wrench provided and pull up on the eccentric roll handle. A pointer gage (See Figure 36) on the eccentric roll bearing housing can be used as a reference for wider roll gaps. Each mark on the gage is approximately 0.015 inch of additional roll gap. Always re-tighten the eccentric lock bolts when processing, otherwise the roll gap will open and feed particle size will increase.

To check the roll gap, remove the 20 inch magnet (See Figure 37) from the hopper throat. Using a feeler gage, check the current roll gap with the eccentric roll handle down on the stops and the eccentric lock bolts snugged down. Be sure to check the roll gap at the front and back of the rolls. Also rotate the rolls to check several different places on the roll diameter, as there may be 0.001 to 0.002 inch difference in the concentricity of the rolls.

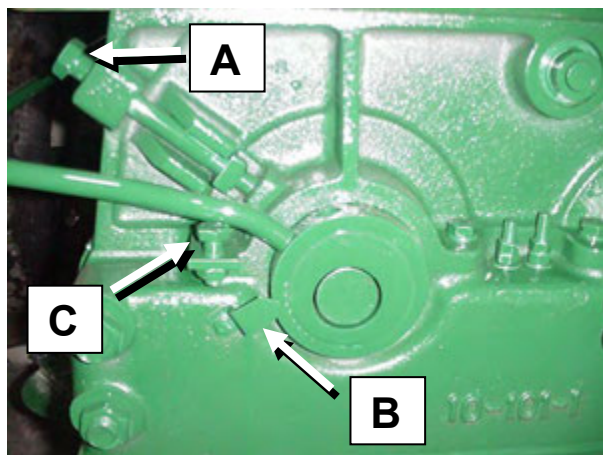

Figure 36 - Roller mill Housing Eccentric Bearing. A - Eccentric Lock Bolts, B - Pointer Gauge, C - Stop Bolts.



Figure 37 - Removing Magnet To Check Roll Spacing.

To change the minimum roll gap, loosen the eccentric lock bolts and pull the eccentric roll handle up and out of the way. Loosen the jam nuts on the 1/2 inch stop bolts (See Figure 36) and turn both the front and rear stop bolts evenly, up for a wider roll gap and down for a smaller roll gap. Lower the eccentric roll handle to the stop bolts and re-tighten the eccentric lock bolts. Re-check the roll gap and repeat as necessary until the desired roll gap is attained. Be sure to re-tighten the jam nuts on the stop bolts when finished.

NOTE: Rolls must not be set closer than 0.008 inch gap. Never adjust the minimum roll gap setting with the tractor PTO engaged. The roller mill rolls will be severely damaged if they ever touch while the PTO is engaged.

ROLL PARALLELISM

If the roll gap is different from front to back on the rolls, the rolls are out of parallel and need to be adjusted. This can occur from the eccentric roll handle getting bent or twisted, or uneven roll wear

from not keeping the hopper full across the whole width while processing. To adjust roll parallelism, reset one stop bolt up or down. Be certain to push down on each corner of the eccentric roll handle when tightening the eccentric lock bolts to ensure both sides of the handle are in contact with the stops. The eccentric roll handle may have to be twisted to accommodate an excessive stop bolt adjustment.

ROLL SCRAPERS

Roll scraper clearance needs to be monitored as the rolls wear and should be adjusted after changes in a minimum roll gap setting or when replacing rolls. The main drive roll scraper should be set at 0.006 inch clearance and the eccentric roll should be set at 0.050 inch clearance. Be sure the minimum roll gap is set and the rolls locked in place before setting the scrapers.

To adjust the roll scrapers, loosen the jam nuts on the scraper adjustment bolts (See Figure 38). Turn the adjustment nut clockwise to bring the scraper closer to the roll. Turn the roll by hand while adjusting the scraper. When the scraper contacts the roll, back the adjusting nut off slightly until no scraper to roll contact can be heard. On the opposite side of the mill (front to back) turn the adjustment nut on the same scraper until the scraper contacts the roll. Back the adjustment nut off slightly until no scraper to roll contact can be heard. Recheck the side of the mill you started on and repeat the procedure if further adjustment is needed.



Figure 38 - Roll Scraper Adjustment Bolts

Repeat this procedure for the opposite roll. To check for actual scraper clearance, remove the side panels of the mill and measure the clearance with a feeler gage.

NOTE: Do not adjust rolls scrapers with the tractor PTO engaged. Roll to scraper contact with the PTO

engaged will severely damage the rolls and scrapers.

HYDRAULIC SWING ADJUSTMENT

If any problem is encountered with the hydraulic swing adjustment drive, adjust and/or check as follows (See Figure 39):

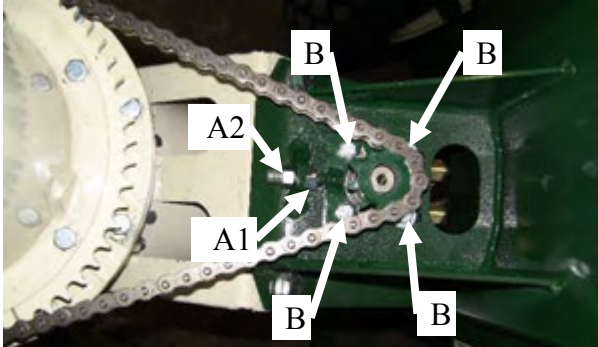

Figure 39 - Hydraulic Swing Adjustment (Shields Removed for Clarity).

1. Loosen the two tension nuts "A1" & "A2", and the four hydraulic motor bolts "B", and then remove the #60 chain.
2. Wrap the #60 chain completely around the 50 tooth sprocket. Inspect the chain, matching the sprocket teeth in the two areas where the sprocket is split. If the rollers on the chain do not seat into the root of the sprocket teeth, loosen the 6-bolts that hold the sprocket to the upper ring; holding the chain across the split areas, re-tighten the bolts so the chain properly seats into the sprocket teeth.
3. Tighten tension nut "A1" to set the proper tension on chain. Re-tighten the hydraulic motor bolts "B", and then check the alignment of the sprocket. If the sprocket is not aligned properly, loosen the set screws on the 10 tooth sprocket and re-align. Tighten tension nut "A2" to lock hydraulic motor in place.

SWIVEL STOP

An unloading auger swivel stop prevents the unloading auger from contacting the mixing tank when moved from the storage position (See Figure 40). Relocate the lower stop so it makes contact with the bracket before the unloading auger contacts the tank.

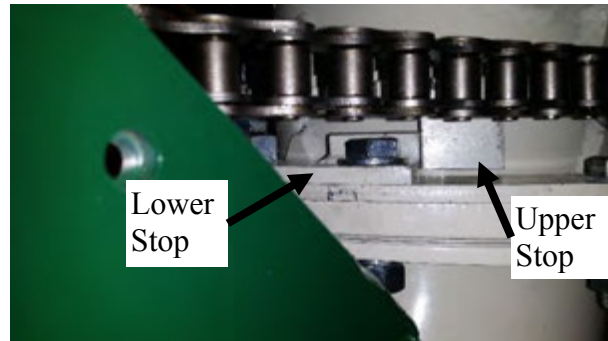

Figure 40 - Hydraulic Swing Adjustment (Shields Removed for Clarity).

SWIVEL STOP ADJUSTMENT

Loosen the bolts holding the Lower Stop (See Figure 0). (Do not loosen the bolts for Upper Stop, it is fixed.) Adjust the Lower Stop so it makes contact with the Upper Stop when the Discharge Auger is in the Saddle. The rear upper stop is placed from the factory to prevent over rotation of discharge auger (See Figure 41).

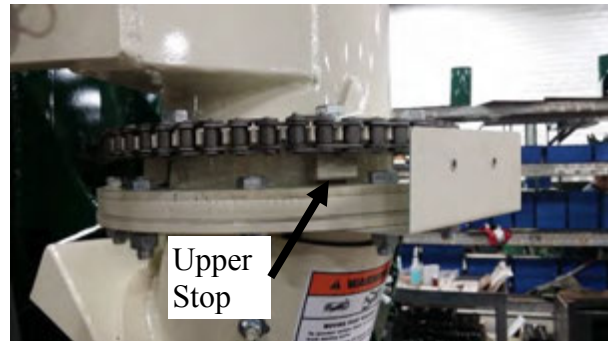

Figure 41 - Rear Swivel Stop (Shields Removed for Clarity).

DISCHARGE AUGER DRIVE ADJUSTMENT

There is an upper and lower location for the Discharge Auger Drive chains (See Figure 42).



Figure 42 - Discharge Auger Drive Chain (See Arrows).

If chain drive "A" (See Figure 43) for the Discharge Auger Drive becomes loose. Loosen the Hydraulic Motor bolts "B" holding the Hydraulic Motor. Then loosen nuts "C". Screw in bolts "D" equally until chain is tight. Retighten nuts to lock bolts in place. Retighten Hydraulic Motor bolts "B".

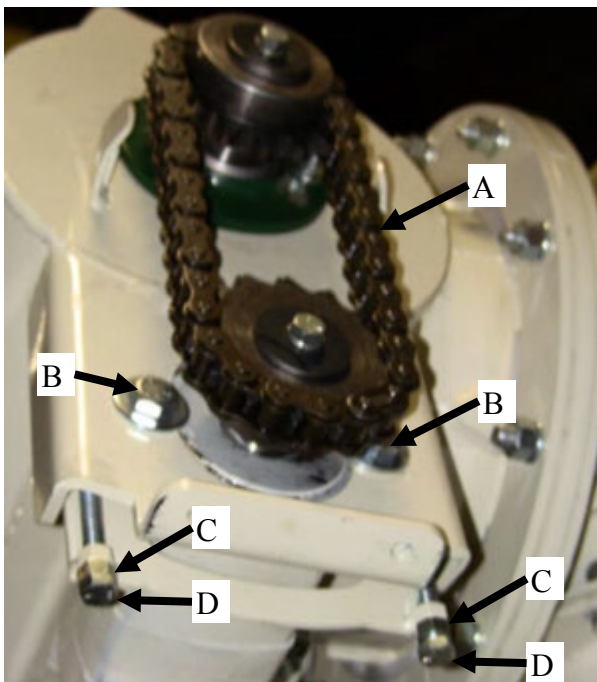

Figure 43 - Discharge Auger Drive Chain (Shield Removed for Clarity).

OPEN AND CLOSED CENTER TRACTOR HYDRAULICS

As the standard, this machine is equipped for tractor “Open Center” hydraulic operation. If the operation of the Auger Feeder or Roll Feeder is to be with a tractor that is equipped with a “Closed Center” hydraulic system, a revision to the plumbing at the Flow Control Valve bypass should be made. *Refer to the tractor operator’s manual or consult your local tractor dealer to make sure which system the tractor is equipped with.*

To convert to “Closed Center” hydraulic system, revise by removing the Tee that goes into the Flow Control Valve and replace it with a Plug (SAE -10 ORB) in the Flow Control Valve and connecting the two hose together with a Union (SAE -8 JIC) fitting (See Figure 44 and Figure).

If the system has two control valves for the Auger Feeder and Roll Feeder, change only the Roll Feeder Flow Control Valve.

IMPORTANT: *When hydraulics are revised for “Closed Center” operation, do not use on a tractor with “Open Center” hydraulics.*

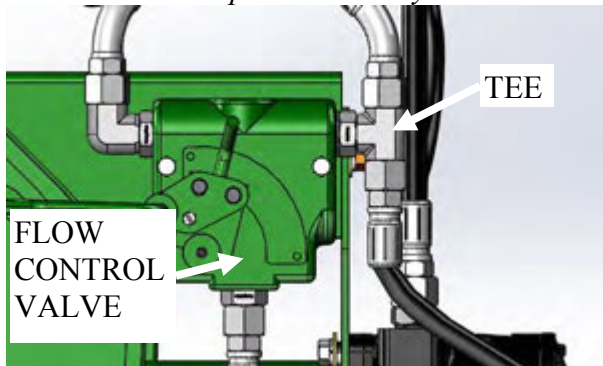

Figure 44- Open Center Hydraulic System.

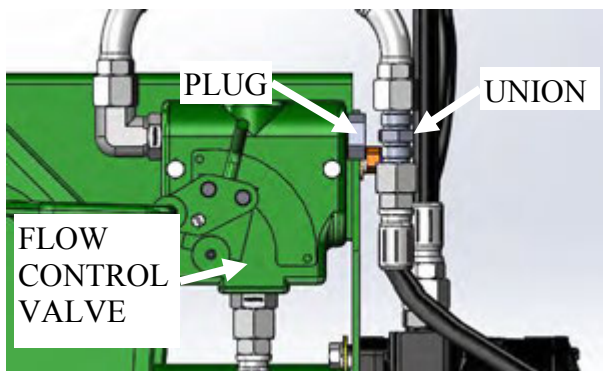

Figure 45 - Closed Center Hydraulic System.

WHEEL BEARINGS

Raise the frame and make sure it is blocked securely so the wheels may turn freely (make sure the opposite wheel is also blocked securely). To tighten the wheel bearing, remove the hub cap. Remove the cotter pin from the slotted nut and tighten the slotted nut while rotating the wheel. Loosen or back-off the nut to the nearest slot, insert and spread the cotter pin.

There should be a slight drag on the bearing following the adjustment. Replace the hub cap (See Figure 46).



Figure 46 - Wheel Bearing Adjustment.

LUBRICATION



CAUTION: BEFORE LUBRICATING THE MACHINE, MAKE SURE THE ENGINE IS SHUT OFF, PLACE THE KEY IN YOUR POCKET AND DISCONNECT THE IMPLEMENT INPUT DRIVELINE

The grinder mixer is designed to require a minimum amount of lubrication. The points that are to be lubricated should be serviced regularly at the specified intervals listed in this manual.

Keep your supply of lubricating oil and grease in clean containers and covered to protect them from dust and dirt.

Keep the lubricating gun nozzle clean and free from dirt at all times. Wipe all of the dirt from the grease fittings before lubricating them.

PTO DRIVELINE

Grease PTO sliding shafts every 20 hours. Zerk is located on the outer shaft and is accessible through cutout slots in spin shields (See Figure 47).



Figure 47- PTO Driveline Shaft (See Arrow).

Grease the bearing crosses and plastic shaft bearings every 20 hours. The bearing cross zerk can be accessed through round hole in PTO spin shield (See Figure 48).

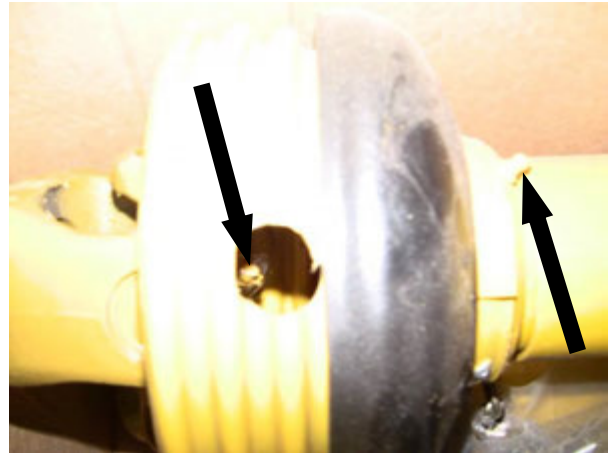

Figure 48 - PTO Driveline Cross Bearing (Left Arrow) and Plastic Shaft Bearings (Right Arrow).

GRAIN CONTROL GATE

Grease the pivot points and slide on the grain control gate once a year or every 100 hours of operation (See Figure 49).

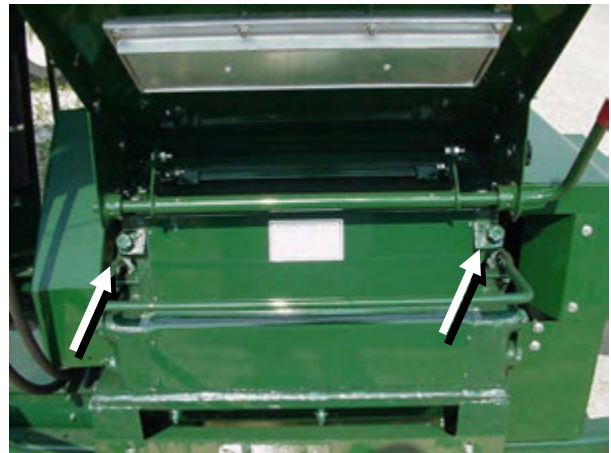

Figure 49 - Grain Control Gate Lubrication (2 Zerks and Slide Guides).

ROLL BEARINGS

The roller mill roll shaft bearings are a sealed bearing and require no additional lubrication. Monitor the condition of these bearings and replace if overheating of the shaft or roller mill housing occur. New bearings are supplied with replacement rolls.

ECCENTRIC BEARING HOUSINGS

The bearing housings on the eccentric roll shaft are greased at the factory and should not require additional lubrication under normal operating conditions. These housings should be cleaned and re-lubricated if the eccentric roll becomes hard to

move or whenever the mill is torn down for service (See Figure).

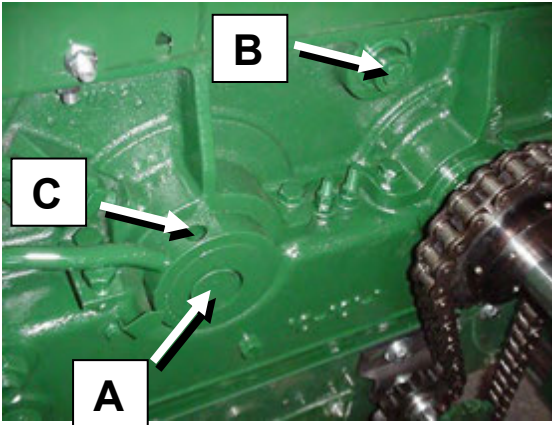

Figure 50- A - Roller mill Bearings, B - Agitator Shaft Bearings, C - Eccentric Housing

AGITATOR SHAFT BEARINGS

The agitator shaft bearings are a sealed bearing and require no additional lubrication. Monitor the condition of these bearings and replace if overheating of the shaft or roller mill housing occur.

ROLLERMILL BELT DRIVE

Be certain to maintain the proper belt tension on the roller mill eccentric drive, as belts will stretch during their break in period. Keep the spring-loaded idler properly tensioned and lubricated to pivot freely (See Figure). Improper tensioning or overloading will cause the belts to slip and causing premature wear and reduced belt life.

The idler pulley bearings on the roller mill belt drive are a sealed bearing and require no additional lubrication. Monitor the condition of these bearings and replace as necessary.



Figure 51 – Roller mill Belt Drive

HOPPER MAGNETS

Periodically check the hopper magnets for tramp metal and debris and clean as necessary. Open the hopper lid to inspect the hopper plate magnets. Always clean the plate magnets with the throat magnet installed. Remove the throat magnet for cleaning and inspection. Be sure not to let any material from the magnets fall into the roller mill (See Figure 52).



Figure 52 - Cleaning Magnets

DRIVE SHAFT BEARINGS

Grease pillow block bearings on the lower line shaft once a month or every 30-40 hours of operation (See Figure and Figure). Use SAE multi-purpose type grease for these lubrications.

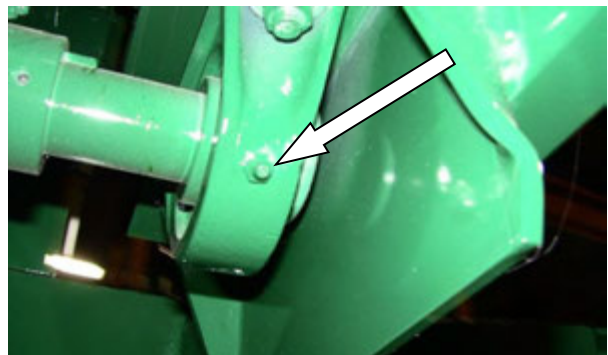

Figure 53 - Mixer Drive Shaft Bearing, Front.

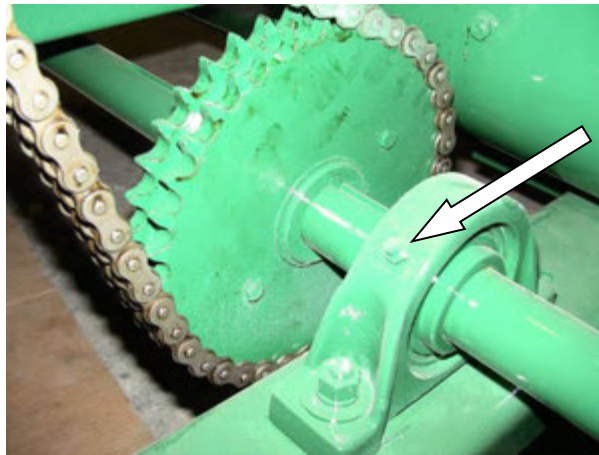

Figure 54 - Mixer Drive Shaft Bearing, Rear (Shield Removed For Clarity).

CHAINS

Chains should be lubricated at frequent intervals. Apply light engine oil (10wt) to the chain or aerosol chain lube. Oil the chain on the inside located in the upper side of lower the strand (See Figure).

The chains should also be cleaned regularly. Remove the chains and dip or soak them in parts cleaning solvent or equivalent. Once the chains have been cleaned, dry and oil them thoroughly.

Oil Roller Chain on Upper Side of Lower Strand

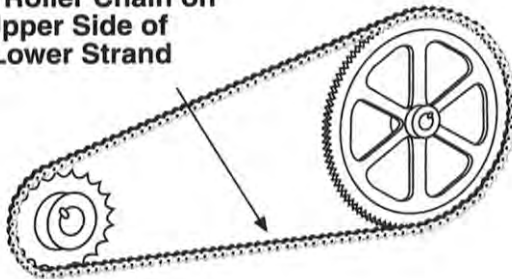

Figure 55 - Oiling Roller Chains.

The split end of the chain clip must face the direction opposite of the chain travel. Make sure the clip is properly seated in the groove on the ends of the pin (See Figure).

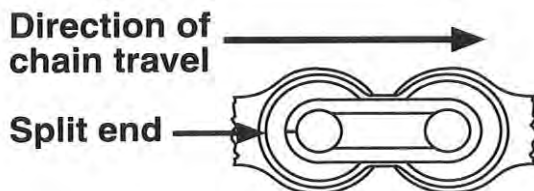

Figure 56 - Chain Spring Clip.

GEARBOX

Make sure to check the oil level of the gearbox at the base of the mixing tank every 24 hours of operation by removing the check plug on the side of the gearbox. Add SAE 90 weight gear oil if necessary and until oil runs out of the check hole (See Figure). Change the oil after the first 50 hours of operation. Routine oil change intervals will vary depending on the severity of the environment. Normal changes should occur between 250 and 1000 hours of operation. The longest life at continuous service will be realized when the oil temperature does not exceed 200° F.

IMPORTANT: Do not overfill.

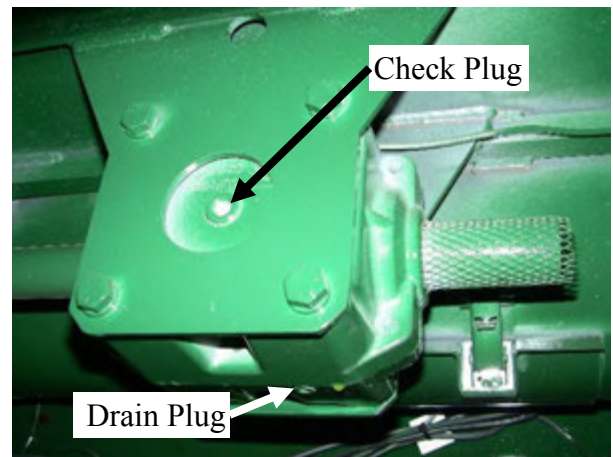

Figure 57 - Gearbox Lubrication.

Grease upper gearbox bearing weekly or every 10-20 hours of operation with SAE multi-purpose type grease, through remote grease zerk located on rear base housing of mixer (See Figure).

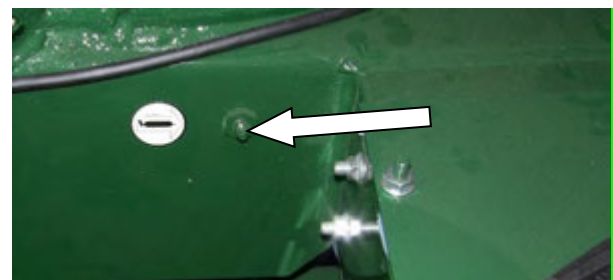

Figure 58 - Gearbox Lubrication Upper Bearing Remote Location (next to Supplement Hopper).

LOWER VERTICAL MIXING AUGER

Refill the grease seal at the bottom of the vertical mixing auger every 6-12 with SAE multi-purpose type grease. Access to this fitting can be gained through the clean-out door in the mixing tank cone, below the large bottom flight of the mixing auger (See Figure). This is only done to reduce the feed from accessing the coupler cavity.

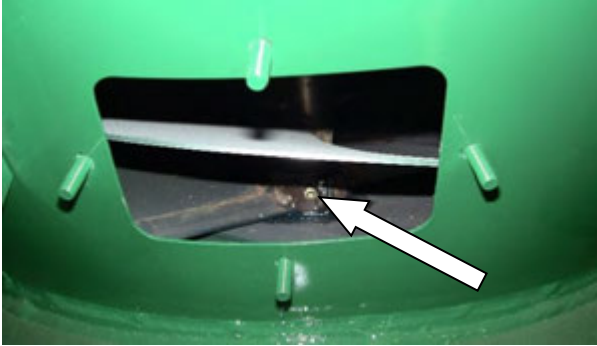

Figure 59 - Clean-Out Door in Mixing Tank Cone And Grease Zerk For Seal At Bottom Of Vertical Mixing Auger (Door Removed for Clarity).

UPPER VERTICAL MIXING AUGER

Grease the upper vertical mixing auger bearing weekly or every 10-20 hours of operation with SAE multi-purpose type grease. Access to this bearing can be gained through the top of the mixing tank (See Figure 60).

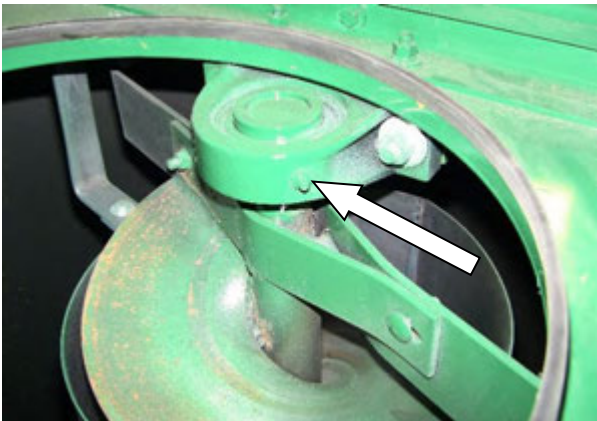

Figure 60 – Upper Vertical Mixing Auger Bearing (Door Open for Clarity).

DISCHARGE U-JOINT

Grease the Discharge U-Joint weekly or every 10-20 hours of operation with SAE multi-purpose type grease. Access to this u-joint can be gained through the transition door (See Figure 61). There are two lube points on u-joint.

Note: *There is a third zerk in one of the yokes that is just a spare.*



Figure 61 – Discharge U-Joint (Door Removed for Clarity).

DISCHARGE PIVOT PIN

Lubricate the Discharge Pivot Pin periodically with light machine oil (See Figure 62).

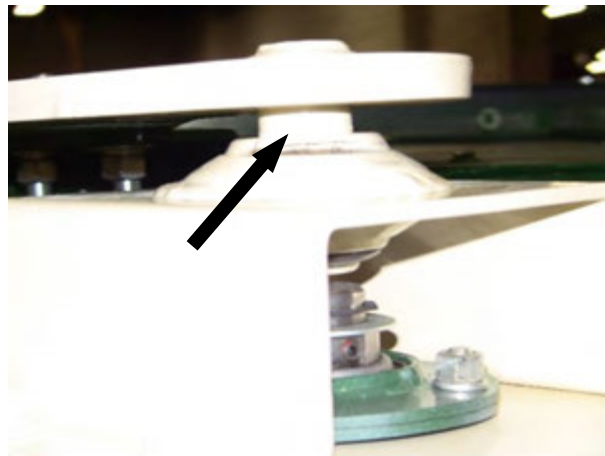

Figure 62 – Discharge Pivot Pin.

WHEELS

Remove, clean, and repack the wheel bearings once a year or every 100 hours of operation using SAE multi-purpose type grease (See Figure).



Figure 63 - Wheel Bearing Lubrication.

SERVICE

TORQUE SPECIFICATIONS



CAUTION: DISENGAGE ALL DRIVES AND MAKE SURE THE TRACTOR ENGINE IS SHUT OFF. PLACE THE KEY IN YOUR POCKET AND DISCONNECT THE PTO DRIVELINE PRIOR TO SERVICING THE GRINDER MIXER.

When performing service on the grinder mixer and its components, take time to use and comply with the torque specification guide. (Refer to Table 4.)

Size	Clamp Load	Plain GR 5	Plated GR 5
1/4 – 20 (.250)	2,025	8 ft. lbs.	76 in. lbs.
5/16 – 18 (.3125)	3,338	17 ft. lbs.	13 ft. lbs.
3/8 – 16 (.375)	4,950	31 ft. lbs.	23 ft. lbs.
7/16 – 14 (.4375)	6,788	50 ft. lbs.	37 ft. lbs.
1/2 – 13 (.500)	9,075	76 ft. lbs.	57 ft. lbs.
9/16 – 12 (.5625)	11,625	109 ft. lbs.	82 ft. lbs.
9/16-18 (wheel bolt)	12,950	NA	70-80ft. lbs
5/8 – 11 (.625)	14,400	150 ft. lbs.	112 ft. lbs.
3/4 - 10 (.750)	21,300	266 ft. lbs.	200 ft. lbs.
7/8 – 9 (.875)	29,475	430 ft. lbs.	322 ft. lbs.
1 – 8 (1.00)	38,625	644 ft. lbs.	483 ft. lbs.
1-1/8 – 7 (1.125)	42,375	794 ft. lbs.	596 ft. lbs.

Table 4 - Torque Specification Guide for Grade 5 Bolts.

SHEAR BOLTS



WARNING: SHEAR BOLTS MAKE A LOUD NOISE WHEN SHEARED. IMMEDIATELY SHUT THE TRACTOR IGNITION OFF AND DETERMINE THE CAUSE OF SHEARING.

Shear bolts will make a loud noise when they shear. This is your warning to turn off the tractor ignition immediately and determine the cause of the shear.

Shear bolt locations on the CattleMaxx are:

- The PTO driveline shear clutch
- The mixer drive #80 sprocket on the lower drive shaft

- The mill to mixer and supplement auger drive #40 sprocket on the lower driveshaft
- Discharge auger drive clutch on the gearbox output shaft.

Drive	Location	Bolt/Pin	Part No.
PTO Driveline	PTO Shear Clutch	Bolt, M10-1.5 x 60 (metric)	407760
Mixer Drive	#80 Sprocket, Lower Driveshaft	Bolt, 1/4-20 x 1-1/2 Grade 5	047000
Mill To Mixer Auger	#40 Sprocket, Lower Driveshaft	Bolt, 1/4-20 x 1 Grade 5	042960
Discharge Auger	Rear Drive Clutch	Clevis Pin, 3/8 X 2-3/8	041540

Table 6 - Replacement Shear Bolts

If these designed shear points are not the problem than most likely a sheared keyway in an individual components is the problem. Clear the obstruction that caused the overloading and repair/replace components as necessary.

When replacing sheared bolts, always tighten them securely using lock nuts. The shear bolts must be the correct harness to ensure safety. (See Figure 64)

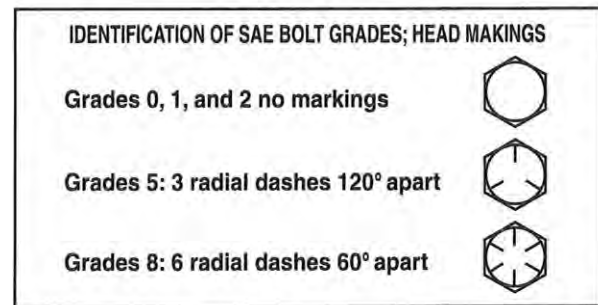

Figure 64 - SAE Bolt Identification.

Warning: using a harder bolt in a shear bolt location can cause damage to vital and more expensive drive components.

SPROCKET AND CHAIN ALIGNMENT

Make sure the sprockets are in line with the shafts (See Figure and Figure). If the sprockets are not aligned a sideways pull will develop and will concentrate the load on sides of the sprocket teeth and on the side of the chain (See Figure 67). This faulty alignment will result on excessive wear on both the chain and sprockets.



Figure 65 - Mixer Sprocket (Shields Removed For Clarity).



Figure 66 – Mill To Mixer Sprocket (Shields Removed For Clarity).

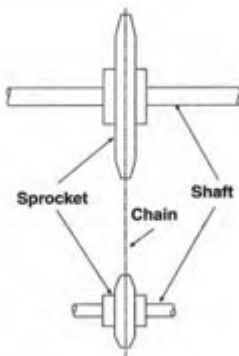

Figure 67 - Sprocket Alignment.

Adjust mounting of main drive bearings (See Figure 68) so that the sprocket on the mixing auger shaft and sprocket on the gearbox are running on center. Tighten bearing bolts. Run grinder mixer slowly and observe the mixing auger shaft. If shaft is in need of further adjustment to better align sprockets; for position of the sprockets (See Figure). Excessive wear of chain and sprockets will result if sprockets are not centered properly.

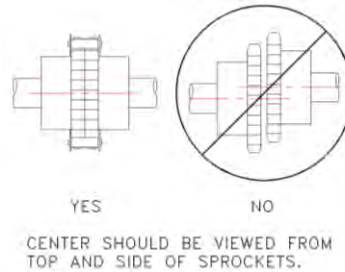

Figure 68 - Chain Coupler Alignment.

ROLL REPLACEMENT

When using roll combinations with different grooves (sharp to sharp or flat to flat) the coarser grooved roll is the drive roll. When combining sharp and flat rolls with same number of grooves, the drive roll is the sharp roll. Ensure rolls and shafts are the proper combination before installing.

Replacement 20 inch rolls are supplied with shafts and bearings. To replace the rolls, perform the following:

1. Remove the PTO, front and rear guards, rear belts drive, and front drove chain.
2. If the CattleMaxx is equipped with an auger feeder, remove the pivot pin at the top of the hopper and support the auger feeder off to the side.
3. Remove the 4 bolts on the front and rear roller mill castings that hold the top and bottom halves of the mill together. Lift the top half off in one assembly. Pick up and save the two brass plugs that were in the upper castings beneath the eccentric tightener bolts.
4. Lift out the rolls and remove any pulleys, sprockets, and bearing housings. For 20 inch rolls leave the old shaft and bearings with the worn rolls. The roll handle is a press fit into the bearing housings. Use care when removing the bearing housings as they can be easily damaged by hammer blows.
5. Thoroughly clean the machined surfaces of the top and bottom castings. Press the bearing housing onto the new roll assemblies. Replace the adjusting handle on the eccentric roll.
6. Grease the outside of the bearing housings and place the roll assemblies in the bottom half of the mill. The dowel spacers in the bottom casting will position the rolls front to back.
7. Replace the top half of the mill and securely bolt into place. Check that the rolls will turn without interference and the eccentric handle will move freely.
8. Replace all pulleys, sprockets, belts, and chains as well as the two brass plugs below the

-
- eccentric lock bolts. Replace the front and rear guards.
9. Replace the auger feeder to the hopper lid if applicable.
 10. Set the roll gap as described in the "adjustment" section of this manual. Set the rolls for proper minimum gap and parallelism.
- Set the roll scrapers for the new rolls as described in the "Adjustments" section of this manual.**

TROUBLESHOOTING GUIDE

The majority of difficulties are caused by improper adjustments. When you encounter trouble, perform a systematic check of all possible adjustments using the chart that follows. If difficulties cannot be corrected by making the adjustments that follow, consult your local **Art's Way authorized dealer** for further assistance.

TROUBLE	POSSIBLE CAUSE	POSSIBLE REMEDY
PTO driveline is hard to telescope and hard to connect	Shafts are twisted due to overloading of the mill	Replace PTO driveline if necessary. Check for proper shear bolt in PTO shear clutch.
	Lack of grease on the sliding halves	Lubricate as necessary
	Tractor drawbar improperly adjusted.	Adjust tractor drawbar.
Excessive noise when turning the mixer while it is in operation	Turning the mixer too sharply	Avoid sharp turns
	Lack of grease on sliding halves	Lubricate as necessary
	Tractor drawbar improperly adjusted	Adjust tractor drawbar.
Tractor engine RPM falls below the rated PTO speed while grinding	Overloading mill	Close grain control gate.
	Drive belts too loose	Tighten belts
	Drive belts wore	Replace drive belts.
	Material packing on rolls	Adjust scrapers Open roll gap Install roll speed differential.
Shear pins break	Foreign objects and debris (nuts, bolts, etc.) in mill, mixers, or augers	Remove foreign objects.
	Grain in mill on start-up	Open eccentric roll to let grain flow through. Clean material from rolls.
	High RPM starts and stops	Lower RPM PTO engage and disengage. Gradually speed up and slow down.
Mill vibrates excessively while in operation	PTO driveline is not properly aligned	Front of CattleMaxx main shield must be parallel to tractor axle
	PTO driveline is bent	Replace the PTO driveline
	Overloading mill (low rumbling)	Close down grain control gate/open roll gap.
	Tractor drawbar is not adjusted properly	Adjust the tractor drawbar.
Rollermill loses capacity	Grain gate open too far	Close grain control gate
	Material packing on rolls – high moisture material	Adjust roll scrapers
	Rolls are worn, gouged, and smooth	Replace with new or regrooved rolls.

TROUBLE	POSSIBLE CAUSE	POSSIBLE REMEDY
Mill will run but the mixing auger does not run	Bolt(s) sheared in the drive	Repair the cause of the bolt(s) shearing and replace bolt(s)
Discharge auger running, but the feed is not unloading	Mixer tank gate is closed	Open the mixer tank gate
	Gate actuator is not working	See next
Gate actuator is not working	Fuse is blown in control box	Replace fuse
	Wire disconnected to actuator	Reconnect or repair wires
	No power to control box	Reconnect to tractor power supply
	Actuator is bad	Replace actuator
Discharge auger will not engage	Discharge auger drive chain(s) broken or slipping	Replace and/or retighten chain(s)
	Discharge auger drive hydraulic motor(s) not working	Check hydraulic system
Discharge auger slows down or stalls	Feed overloading discharge auger	Lower gate to reduce feed flow to rate discharge auger can handle
	Reduced hydraulic fluid flow to motors	Increase hydraulic fluid flow (GPM) to motors
Discharge auger jerks when it is raised or lowered	Excessive hydraulic flow rate to lift cylinder	Adjust the flow rate with the Flow Control Valves
	Air in hydraulic line or cylinder	Run grinder mixer at low rpm 5-10 minutes. During this time, activate discharge lift cylinder to ensure that air is removed from system
	UHMW washers in joint worn or damaged	Replace UHMW washers in joint
Discharge auger raises and lowers too slowly	Incorrect hydraulic flow rate to the lift cylinder	Adjust the flow rate with the Flow Control Valves
	Air in hydraulic lines	Run grinder mixer at low rpm 5-10 minutes. During this time, activate discharge lift cylinder to ensure that air is removed from system
Auger feeder stops when the mill is engaged	Hydraulic flow control valve is disengaged	Engage the flow control valve

HYDRAULICS: INTRODUCTION

This section of the manual has been prepared to acquaint you with the proper operation, adjustment, lubrication, and service of the 6140 with self-contained and tractor hydraulics. Take time to read and understand both this manual and efficient operation of your portable unit. The best insurance from an accident is a careful and knowledgeable operator.

Note: Some pictorials used show guards and shields removed for easy identification. Be sure that all shields and guards are in place before operating. These are for your protection.

The self-contained hydraulic system features a hydraulically driven discharge, and an auger feeder

with or without roll feed. Also available are electric linear actuator used to operate the discharge door.

This system can be used with any tractor that can maintain a rated PTO speed when grinding.



WARNING: BECAUSE THE OPERATOR IS ALLOWED TO OPERATE THE SYSTEM WITHOUT LEAVING THE TRACTOR, SPECIAL CARE IS NEEDED TO AVOID INJURY OR DAMAGE. WHEN LOCATING THE DISCHARGE TUBE INTO POSITION, STAY CLEAR OF OVERHEAD POWER LINES, FARM BUILDINGS AND ANYONE IN THE AREA.

HYDRAULICS: PREPARING FOR OPERATION

Prepare the grinder mixer and tractor as instructed in the grinder mixer sections of this manual. Additional preparation is needed to operate the self-contained portion.



WARNING: WHEN PREPARING THE TRACTOR AND GRINDER MIXER FOR OPERATION, MAKE SURE PTO IS DISENGAGED, TRATOR ENGINE IS SHUT OFF AND PLACE KEY IN YOUR POCKET.

PREPARING THE TRACTOR

The tractor must be equipped with a 540 rpm PTO to match the grinder mixer. Make sure the proper PTO is used.

Connect the power cord to a suitable 12 VDC power supply. The tractor must be able to provide 12-15 volts DC and 10 amperes to operate the electrical control box. The Complete Control Box is equipped with a 20 amp fuse. See Figure for direct connection with the power plug to the battery.

Note: The electrical system of the tractor must be in good working order. If voltage of less than 12.0 volts DC is provided to the actuator or solenoids on hydraulic control valves, the system will not operate properly.

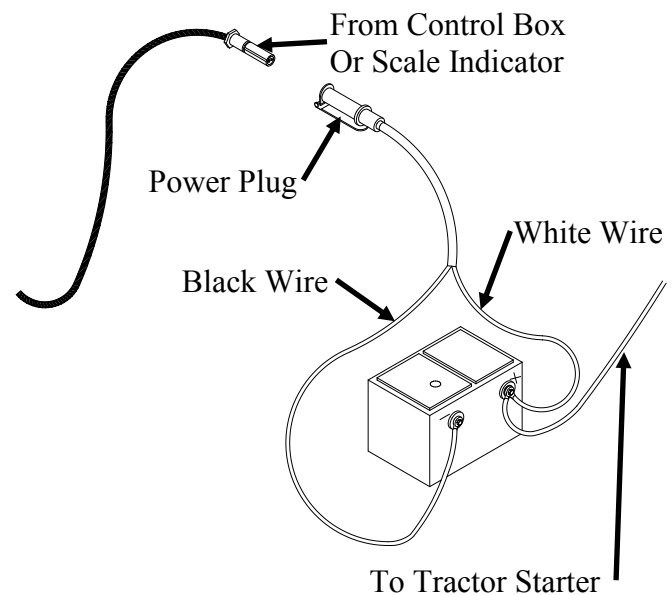

Figure 69 - 12-Volt System power wire hookup to battery

Note: The Control Box power cord can be wired into Scale Box power connector or 6140 7-Pin Light Harness Plug.

PREPARING THE GRINDER MIXER

Electrical Components

Linear Actuator is shipped in Supplement Hopper. Install Actuator base end to the brackets located on the Diagonal Discharge Tube and rod end to the Tabs on the Discharge Gate (See Figure 70). Connect Wire Coupler to coupler on actuator. Apply silicon sealant to the threads of the Indicator Tube and screw it onto the threaded stud on the Discharge Gate.

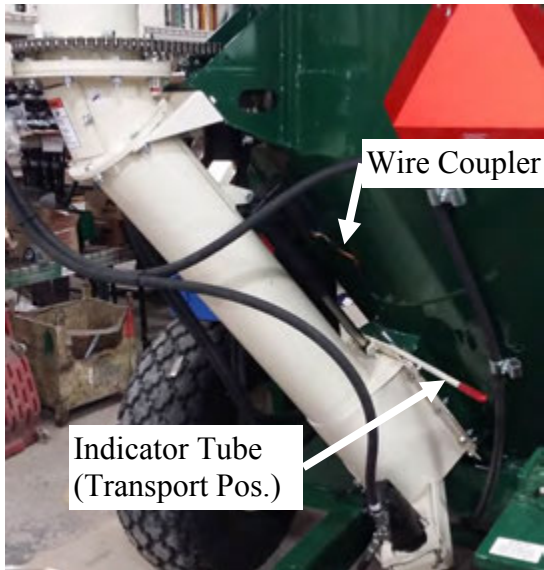

Figure 70 - Actuator Installation (Shown with the Gate in the Closed Position).

Activate the electric linear actuator to open and close discharge gate. It will ratchet when actuator is

fully retracted at this point the gate should be fully opened.

The actuator is electrically actuated from a control box that is mounted in tractor or operator's preferred location.

HYDRAULIC COMPONENTS

Check all connections and fittings for oil leaks.

Check oil level in reservoir. Oil level should be maintained 2-3 inches below top of reservoir and viewable on the sight gauge.

Run grinder mixer at low rpm 5-10 minutes. During this time, activate all hydraulic motors (discharge, auger feeder, and roll feed) to ensure that air is removed from system.

Adjustable valves to control the rate of swing are located in-line with hydraulic hoses. For faster swing, turn control screw out. Set both valves at approximately the same setting.

Adjustable valve to control the rate of lift and drop of the discharge auger is located in-line with hydraulic hoses. For slower lift, turn control screw in.

The pre-set dual pressure relief bypass are mounted in-line with the hydraulic hoses and control valves to protect the discharge auger from damage if it contacts an obstacle.

Recheck all hydraulic connections and fitting for leaks.

Recheck oil level reservoir.

HYDRAULICS: OPERATION



CAUTION: ALWAYS OPERATE PTO AT SPEED FOR WHICH THE MACHINE IS EQUIPED: 540 RPM. NOTE THE SPEED DECAL ON THE FRONT SHIELD.

The grinder mixer should be run at a slow idle for a few minutes when the temperature drops below 0° F to allow the hydraulic oil to warm up.

For information on operating the auger feeder and roll feed, if your machine is so equipped, See the "Operation of Grinder Mixer" section and "Attachments" section.

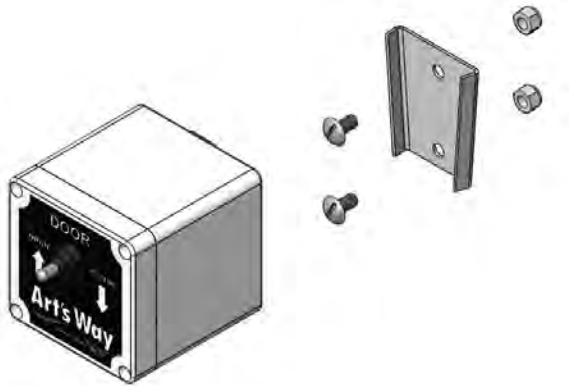

Figure 71 – Electric Actuator Control Box with Internal Replaceable Fuse.

If discharge auger or auger feeder becomes clogged with material or foreign objects, the hydraulic motor will stall. When this occurs, the operator must disengage the tractor immediately so the pump and motor will not be damaged from excessive heat. The overloaded material and/or obstruction must be removed before the operation can be continued.

Note: *The electrical system of the tractor must be in good working order. If voltage of less than 12.0 volts DC is provided to the actuator or solenoids on hydraulic control valves, the system will not operate properly (Black=Ground, Red/White=+12V)*



WARNING: BEFORE ATTEMPTING TO CLEAR A BLOCKED AUGER, DISENGAGE PTO, SHUT OFF TRACTOR ENGINE, AND PLACE KEY IN POCKET. FAILURE TO HEED THIS WARNING MAY RESULT IN INJURY.

To **Engage** the Discharge Auger Rotate Control Knob counter-clockwise until preferred speed achieved.

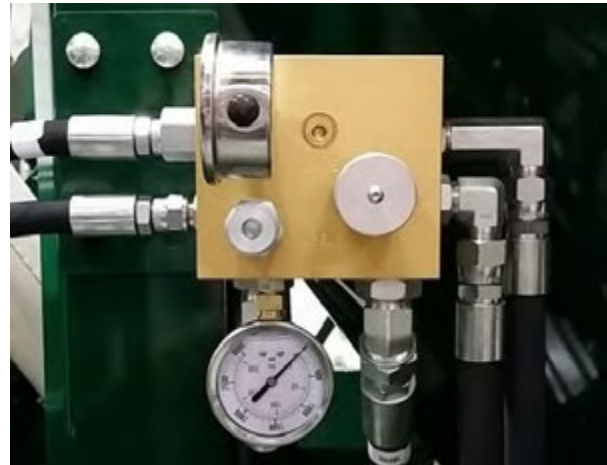

Figure 723- Hydraulic Valve Assembly

To **Disengage** the Discharge Auger Rotate Control Knob clockwise until it comes to a stop. (See Figure 73)

Note: *The manifold discharge valve has 10 positions to choose from. This will determine the amount of hydraulic fluid to the Discharge Motors. Recommended to run at full flow/speed for optimum performance and to reduce the chance of stalling augers..*

HYDRAULIC SYSTEM PRESSURE RELIEF ADJUSTMENT

To protect the overall hydraulic system from damage, the relief pressure in the manifold valve (RV1) is factory set to 2500 PSI. To adjust the relief, remove the relief valve outer cap with 5/16" hex wrench, and turn adjustment screw with 1/4" hex wrench. Turning the screw in increases the relief bypass pressure and conversely turning the screw out will lower the bypass relief pressure (250 to 3500 PSI range). (See Figure 73)

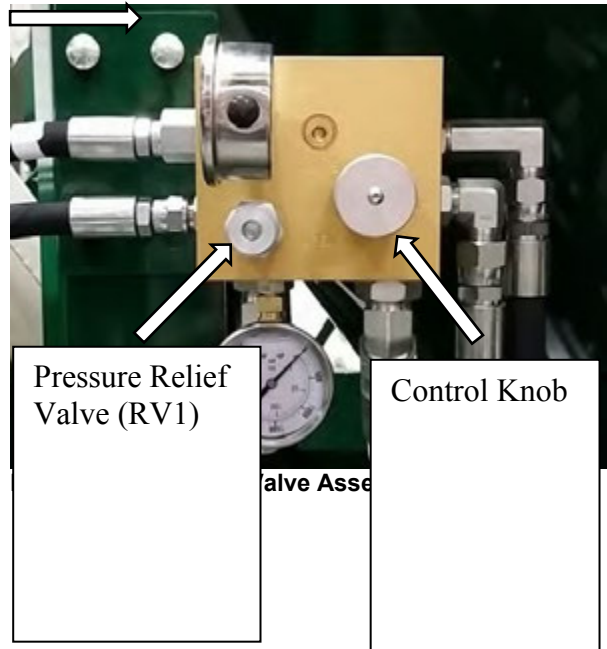

HYDRAULICS: ADJUSTMENT/SERVICE & LUBRICATION



CAUTION: DO NOT CLEAN, ADJUST, OR LUBRICATE THE MACHINE WHILE IT IS RUNNING. MAKE SURE THE ENGINE IS SHUT OFF, PLACE THE KEY IN YOUR POCKET AND DISCONNECT THE IMPLEMENT INPUT DRIVELINE.

MAIN DRIVE CHAIN

Adjust mounting bracket of hydraulic pump so that the sprocket on the main drive shaft and sprocket on the hydraulic pump are running on center. Tighten bearing and mounting bracket bolts and replace shield. Run grinder mixer slowly and observe hydraulic pump. If pump is in need of further adjustment to better align sprockets; for position of the sprockets (See Figure 74). Excessive wear of chain, sprockets, and hydraulic pump will result if sprockets are not centered properly.

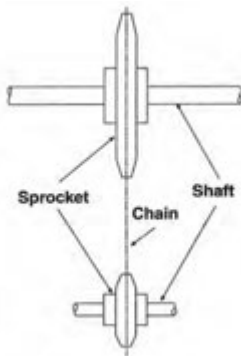

Figure 74 – Sprocket Alignment

LUBRICATION

The chain on the pump coupling should be lubricated with light engine oil (10wt) or an aerosol chain lube before every use.

For other lubrication see the **Lubrication** section of this manual.

HYDRAULIC FILTRATION

The return line filter, mounted on the side of the hydraulic reservoir, traps contaminants before the oil returns to the tank. It is recommended that the element be replaced after the first 100 hours of operation and each 1000 hours or yearly thereafter, whichever occurs first (See Figure 72).



Figure 75 – Reservoir Filter (See Arrow).

A suction strainer is located in the suction port of the hydraulic reservoir tank. Periodically (approximately every 100 hours of use) remove and clean it with compressed air, blowing from inside out or rinsing with mild solvent. If it is damaged or does not cleanup well, replace it with a new strainer (See Figure 76).

IMPORTANT: A clogged strainer increases the chances of cavitation occurring in the intake line and subsequent damage to, and failure of the hydraulic pump caused by a lack of hydraulic fluid flowing through the pump.



Figure 76 – Reservoir Strainer (Black Arrow) and Drain Plug at Front of Reservoir Tank (Red Arrow).

Installed in the drain port of the hydraulic reservoir tank is a magnetic pipe plug. When hydraulic oil is changed, this plug should be removed and any metal particles removed from it (See Figure 76).

NOTE: *New hydraulic oil is not necessarily free from contaminants. New hydraulic oil straight from the drum has a typical cleanliness level of ISO 4406 23/21/18. To add hydraulic oil, and not the dirt, always filter new oil prior to use in a hydraulic system. This can be accomplished by pumping the oil into the hydraulic reservoir through the system's return filter. The easiest way to do this is to install a tee in the return line and attach a quick-connector to the branch of this tee. Attach the other half of the quick-connector to the discharge hose of a drum pump. When hydraulic oil needs to be added to the reservoir, the drum pump is coupled to the return line and the oil is pumped into the reservoir through the return filter. As well as filtering the oil, spills are avoided and the ingress of external contamination is prevented.*

FILLER/BREATHER FILTER

When adding hydraulic oil, back blow through the filler cap with low pressure air. If the filler screen is dirty, remove the ten (10) – 5/16" whiz nuts on the access cover and flush screen with solvent and allow too dry before installing. Prior to replacing the access cover, remove the old gasket material from the cover and tank, then replace gasket material using silicone blue or equivalent (See Figure 77).

If lack of pressure or flow is experienced, check strainer and/or replace filter. Regular servicing of the filter and preventing contaminants from entering the hydraulic oil is the best assurance of reliable and economic operation.



Figure 77 – Hydraulic Reservoir Cap (See Arrow)

HYDRAULICS: TROUBLESHOOTING GUIDE

The majority of difficulties are caused by improper adjustments. When you encounter trouble, perform a systematic check of all possible adjustments using the chart that follows. If difficulties cannot be corrected by making the adjustments that follow, consult your local Art's Way authorized dealer for further assistance.

TROUBLE	POSSIBLE CAUSE	POSSIBLE REMEDY
Discharge auger will not lift and/or swing	Low hydraulic fluid level	Fill reservoir to proper level
	Hydraulic fluid leak	Check all fittings and hoses for leaks
	Relief bypass in manifold valve set at too low of pressure	Increase relief valve pressure Turn knob counter-clockwise
	Contamination in valves	Remove and clean cartridge valves
	Faulty relief valve	Replace relief valve
	Adjustable valves closed	Open valves
	Air in hydraulic lines	Run grinder mixer at low rpm 5-10 minutes. During this time, activate all hydraulic motors and cylinders to ensure that air is removed from system.
Discharge auger will not run	Low hydraulic fluid level	Fill reservoir to proper level
	Hydraulic fluid leak	Check all fittings and hoses for leaks
Discharge door will not open	Actuator not operating	Check electrical connection as above
	Improper voltage or amperes	Use tractor that will provide 12-15 volts DC and 10 amperes
Hydraulic motors run hot	Low hydraulic fluid level	Fill reservoir to proper level
	Extreme temperature difference between motors	Check speed of each motor. -350-400rpm empty Check for leaks and/or proper oil level
Hydraulic system runs slow	RPM's from tractor has fallen below required level	Increase PTO's speed to: -540 but not more than 565 RPM for 540 RPM PTOs
	Clogged filter or strainer	Replace filter Clean strainer
	Low hydraulic fluid level	Fill reservoir to proper level
	Hydraulic fluid has thickened from the cold (winter operation)	Run for 10 to 15 minutes to warm up and thin fluid

ATTACHMENTS

ELECTRONIC SCALE ATTACHMENT

A solid state electronic scale attachment, digital type, is available for your grinder mixer (See Figure 78). The scale attachment consists of load cell sensors mounted on the grinder mixers axle spindles and hitch. They are electronically connected to the indicator bars. The indicator alarm system is integrated into the scale head. Scale accuracies of 1 percent or less are obtained. Complete installation and operating instructions are included with the attachment.



Figure 78 - Scale Head Attachment (EZ2500V Shown).

ADJUSTABLE SCALE ARM ATTACHMENT

The optional scale arm allows the electronic scale to be positioned along a 180° arc off the side of the grinder (See Figure 79). Tension on the pivot point spring can be increased or decreased by tightening or loosening the nut. Periodic grease needs to be applied to the zerk on the pivot point.

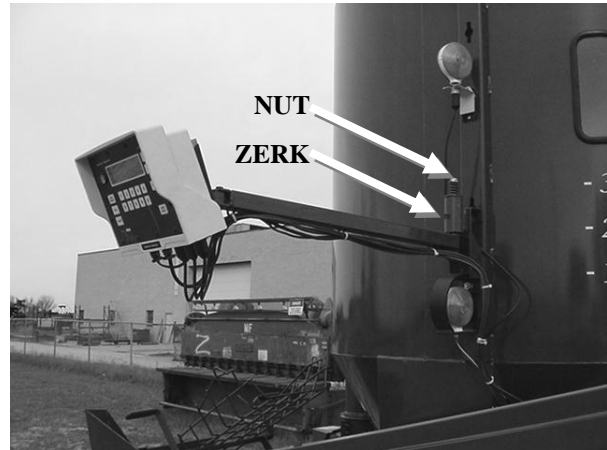

Figure 79 – Adjustable Scale Arm Attachment.

DISCHARGE UNLOADING AUGER EXTENSIONS

3 foot and 6 foot bolt-on discharge auger extensions are available. For unloading height obtainable with various extensions added to the unloading auger system, refer to Table 3. For unloading auger instructions, refer to OPERATION OF GRINDER MIXER section.

SPECIFICATIONS

TANK AND FRAME

- Capacity of mixing tank: 140 bu. /174 cu. ft.
- Height (variable with tire size): 112 inches.
- Width without auger feeder:..... 111 inches.
- Overall length:..... 184 inches.
- Weight:..... 5000-5200 lbs.

DISCHARGE AUGER

- Auger diameter: 7 inches.
- Auger tube diameter: 8 inches.
- Horizontal operating arc: 190°
- Vertical operating arc:..... +57° to -10°

AUGER FEEDER

- Auger length: 117 inches.
- Auger diameter: 7 inches.
- Hopper width open: 23 inches.
- Height of hopper from ground in down position:..... 17-1/2 inches.
- Height of hopper from ground in up position: 42 inches.

MIXING AUGER

- Auger width..... 12 inches.
- Mixing base..... 24 inches.

SUPPLEMENT HOPPER

- Auger diameter 7 inches.
- Hopper size..... 21 inches X 24 inches
- Height from ground 41 inches

ROLLERMILL

- Width of mill Full 20 inches
- Roll diameter..... 10 in.
- Operating speed540 RPM
- Operating speed of mill.....540 RPM
- Roll grooves.....5,7, and 10 (sharp or flat)
- Type drive PTO direct

POWER REQUIRED

- Tractor 50-120 HP

SPECIFICATIONS: SELF-CONTAINED HYDRAULICS

PUMP

- **Type:** Gear Driven Positive Displacement
- **Displacement:** 3.869 cu. in. per revolution
- **Flow (GPM):** 15.6 gallons per minute @ 1000 RPM
- **Input HP Required:** 26.43 HP @ 2500 PSI

HYDRAULIC RESERVOIR

- **Type:** Fabricated pickled and oiled steel
- **Capacity:** 23 gallons
- **Ports:**
 - Suction: -24 ORB (1-7/8-12 SAE)
 - Return: -16 ORB (1-1/16-12 SAE)
 - Drain: 3/4" NPT

FILTERS/STRAINERS/BREATHERS/ INDICATORS

Tank Mounted Suction Strainer

- **Flow Capacity:** 15 GPM
- **Style:** Suction Type
- **Screen Size:** 100 Mesh
- **Thread Size:** -24 ORB (1-7/8-12 SAE) male
 - -16 ORB (1-5/16-12 SAE) female

Tank Mounted Filler Breather

- **Breather Filler:** 40 Micron
- **Strainer Basket:** 30 Mesh

Tank Mounted Temperature/Level Gauge

- **Material:** 40 Micron
- **Strainer Basket:** 30 Mesh

Return Line Filter

- **Material:** Head-Cast Aluminum, Spin-on Canister-Steel, Seals-Nitrile, standard
- **Pressure Rating:** 250 PSI maximum operating, Caution: 80 PSI with Blocked Bypass
- **Temperature Range:** -40°F to +250°F
- **Filtration:** 10 Micron nominal
- **Flow:** 20 GPM
- **Internal Bypass:** Relieves at 15 PSI differential
- **Port Size:** -12 ORB (1-1/16-12 SAE)

HYDRAULIC MOTORS

Auger Feeder/Roll Feeder

- **Type:** Gear, low speed high torque
- **Displacement:** 11.3 cu. in. per revolution
- **Flow (GPM):** 15 GPM cont., 20 GPM inter.
- **Pressure Rating:** 1600 PSI cont., 2150 PSI inter.
- **Ports:** -10 ORB (7/8-14 SAE)

Discharge Auger

- **Type:** Gear, low speed high torque
- **Displacement:** 9.6 cu. in. per revolution
- **Flow (GPM):** 20 GPM cont., 30 GPM inter.
- **Pressure Rating:** 3000 PSI cont., 3750 PSI inter., 4500 max.
- **Ports:** -10 ORB (7/8-14 SAE)

Discharge Swing

- **Type:** Gear, low speed high torque
- **Displacement:** 22.6 cu. in. per revolution
- **Flow (GPM):** 15 GPM cont., 20 GPM inter.
- **Pressure Rating:** 1250 PSI cont., 1500 PSI inter.
- **Ports:** -10 ORB (7/8-14 SAE)

MANIFOLD VALVE ASSEMBLY

Directional Valve Assembly: Consisting of (1) manually operated rotary flow control valve (1) built-in relief valve and (2) stem mount 3000 PSI pressure gauges.

Manifold Valve Assembly

- **Type:** Custom Manifold Block
- **Material:** 6061-T6 Aluminum, Gold Anodized
- **Flow:** System design 16-20 GPM, Max. 25 GPM
- **Max. Pressure:** 3000 PSI @ A1,A2, LD,UD, 3500 PSI @ P, T
- **Max. Fluid Contamination:** Class 21/18/15 to ISO 4406
- **Temperature Range:** -40°F to +248°F Seals
- **Port Sizes:**
 - P: -12 ORB (1-1/16-12 SAE)
 - T: -12 ORB (1-1/16-12 SAE)
 - LD,UD: -10 ORB (7/8-14 SAE)
 - A1,A2: -8 ORB (3/4-16 SAE)

Relief Valves RV1 (Manifold Valve Assembly)

- **Material:** Steel
- **Type:** Cartridge-style, direct-acting, differential area poppet-type hydraulic relief
- **Pressure:** Preset @2500 PSI
- **Adjustable Pressure Range:** 250 - 3500 PSI

Logic Element EP (Manifold Valve Assembly)

- **Material:** Steel cartridge with anodized high-strength 6061-T6 aluminum body
- **Type:** Spool-type, cartridge-style, hydraulic directional element
- **Flow Range:** 0-20 GPM
- **Pressure Setting:** 110 PSI
- **Maximum Pressure:** 3000 PSI

Check Valve CV (Manifold Valve Assembly)

- **Material:** Steel
- **Type:** Cartridge-style, hydraulic check
- **Flow Range:** 0-20 GPM
- **Pressure Setting:** 5 PSI
- **Maximum Pressure:** 3500 PSI

Pressure Gauges G1 & G2 (Manifold Valve Assembly)

- **Material:** Steel
- **Type:** 2-1/2 inch stem mount
- **Pressure Range:** 0 - 3000 PSI

Adjustable Flow Control (Auger Feeder)

- **Material:** Steel
- **Flow Range:** 0-16 GPM
- **Maximum Pressure:** 3000 PSI
- **Port Size:** -10 ORB (7/8-14 SAE)

ELECTRIC ACTUATOR

- **Type:** 12 VDC
- **Load Rating:** 250 lbs.
- **Stroke Length:** 10 inches
- **Overload Protection:** Ball detent overload clutch
- **Drive:** Acme screw thread

ELECTRIC CONTROL BOX

- **Type:** 12 VDC
- **Circuit Breaker:** 20 amp Fuse in Single Switch Control Box

SCHEMATICS: TRACTOR HYDRAULICS

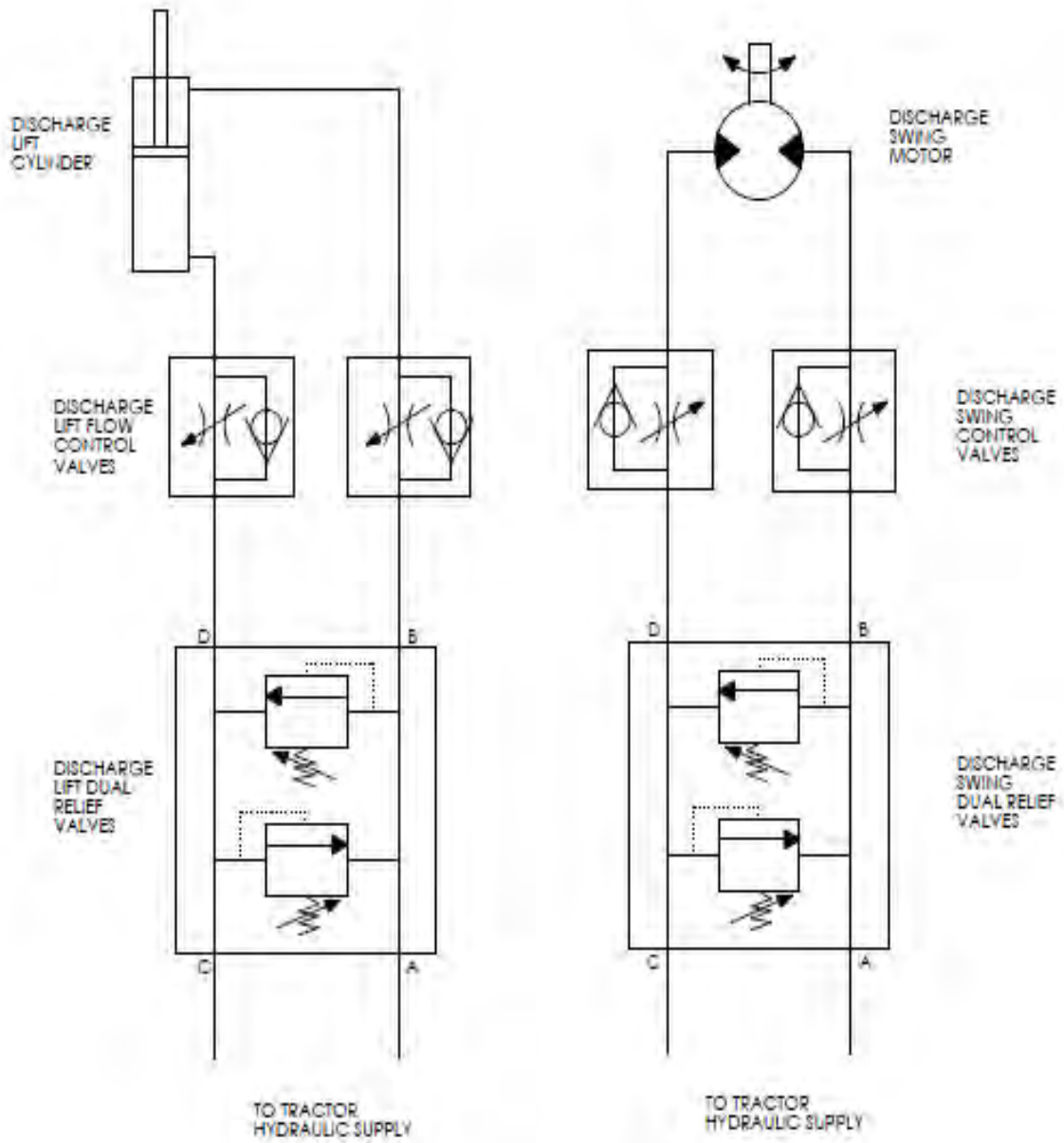

SCHEMATICS: SELF-CONTAINED HYDRAULICS

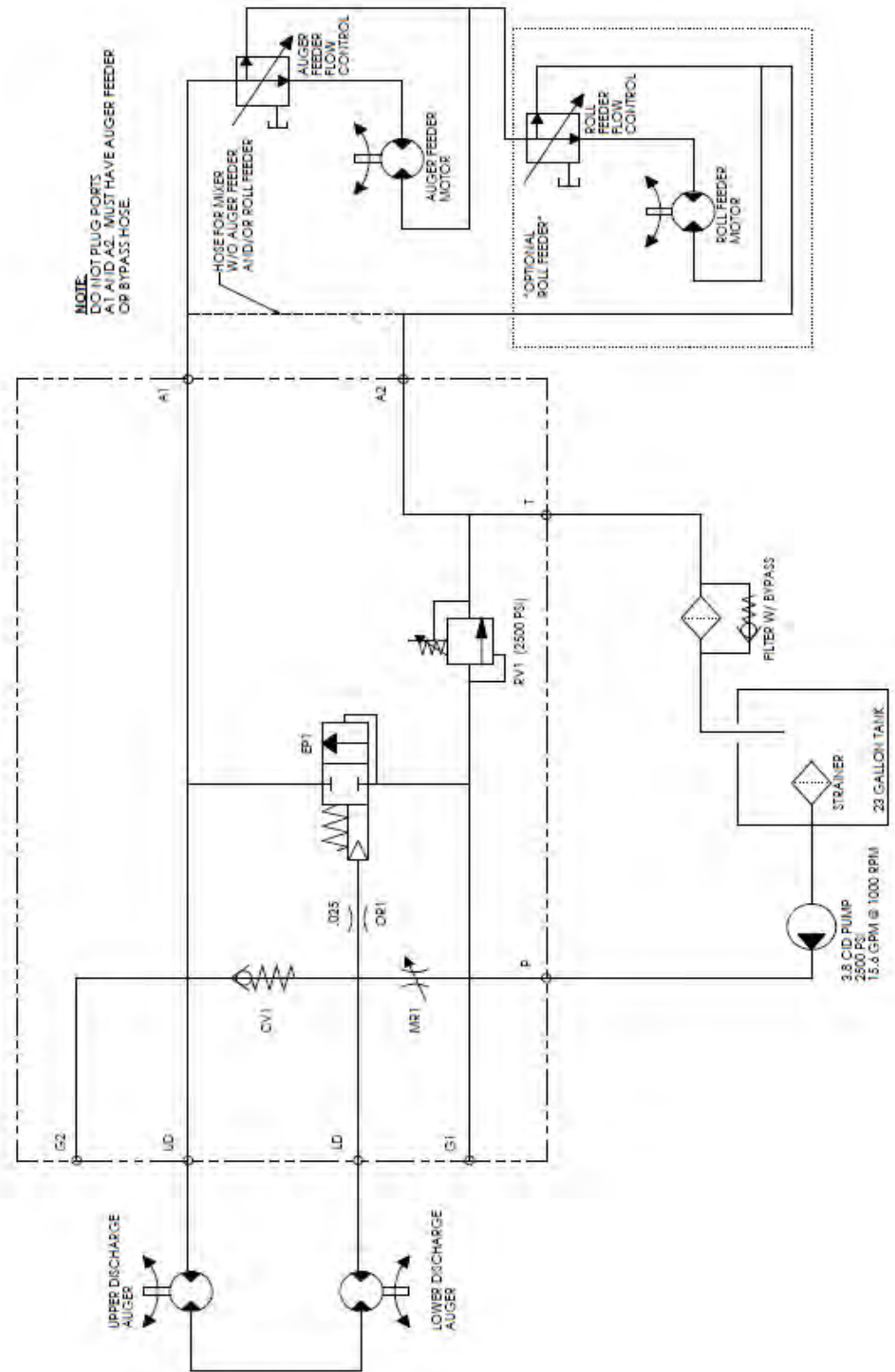



Art's-Way Manufacturing Co., Inc. TECHNICAL MANUALS

Manuals are available from your local dealer or Art's-Way Manufacturing Co., Inc. for the operation, service, and repair of your machine. For prompt convenient service, contact your local dealer for assistance in obtaining the manuals for your machine.

Your local dealer can expedite your order for operator manuals, illustrated parts catalogs, service manuals, and maintenance records.

Always give the Machine Name, Model, and Serial Number so your local dealer can provide the correct manuals for your machine.

Art's-Way Manufacturing Co., Inc. reserves the right to make improvements in design or changes in specifications at any time without incurring any obligation to install them on units previously sold.

Except as expressly authorized, no part of this manual may be reproduced, copied, transmitted, disseminated, downloaded or stored in any storage medium, for any purpose without the express prior written consent of Art's-Way Manufacturing Co., Inc.

**ART'S-WAY MANUFACTURING CO., INC.
HWY 9 WEST - PO Box 288
Armstrong, IA. 50514 U.S.A**

© Copyright 2012
ART'S-WAY MANUFACTURING CO., INC.
All Rights Reserved