



6105

6105  
CATTLEMAXX



## Art's-Way Manufacturing Co., Inc.

Model 6105 & 6105 CATTLEMAXX

Grinder Mixer

Operator's Manual

560500

Issued 07-20

OPERATOR'S MANUAL



*This symbol means **ATTENTION! BECOME ALERT! YOUR SAFETY IS INVOLVED.** The message that follows the symbol contains important information about your safety. Carefully read the message. Make sure you fully understand the causes of possible injury or death.*

IF THIS MACHINE IS USED BY AN EMPLOYEE, IS LOANED, OR IS RENTED, MAKE SURE THAT THE OPERATOR UNDERSTANDS THE TWO INSTRUCTIONS BELOW.

**BEFORE THE OPERATOR STARTS THE ENGINE:**

1. GIVE INSTRUCTIONS TO THE OPERATOR ABOUT SAFE AND CORRECT USE OF THE MACHINE.
2. MAKE SURE THE OPERATOR READS AND UNDERSTANDS THE OPERATOR'S MANUAL FOR THIS MACHINE.

## **WARNING**

IMPROPER OPERATION OF THIS MACHINE CAN CAUSE INJURY OR DEATH.

**BEFORE STARTING THE ENGINE, DO THE FOLLOWING:**

1. READ THE OPERATOR'S MANUAL.
2. READ ALL SAFETY DECALS ON THE MACHINE.
3. CLEAR THE AREA OF OTHER PERSONS.

LEARN AND PRACTICE SAFE USE OF MACHINE CONTROLS IN A SAFE AND CLEAR AREA BEFORE YOU OPERATE THIS MACHINE ON A JOB SITE.

It is your responsibility to observe pertinent laws and regulations and to follow manufacturer's instructions on machine operation and maintenance.

See your Authorized Art's-Way Manufacturing Co., Inc. dealer or Art's-Way Manufacturing Co., Inc. for additional operator's manuals, illustrated parts catalogs, and service manuals.

## TO THE OWNER

Congratulations on the purchase of your new Art's-Way 6105 Grinder Mixer. You have selected a top quality machine that is designed and built with pride to ensure you have many years of efficient and reliable service.

Many people have worked on the design, production, and delivery of this 6105 Grinder Mixer. The information in this Manual is based on the knowledge, study, and experience through years of specializing in the manufacturing of farm machinery. This Manual is designed to provide you with important information regarding safety, maintenance, and machine operation so you can and will get the best possible performance from your 6105 Grinder Mixer.

Even if you are an experienced operator of this or similar equipment, we ask that you **read this manual before operating the 6105 Grinder Mixer.** The way you operate, adjust, and maintain this unit will have much to do with its successful performance. Any further questions you may have about this product of Art's-Way equipment should be directed to your local Art's-Way dealer or to Art's-Way Manufacturing Co., Inc., Armstrong, Iowa, 50514, (712) 864-3131.

### **SPECIFICATIONS AND DESIGN ARE SUBJECT TO CHANGE WITHOUT NOTICE**

Art's-Way Manufacturing Co., Inc. is continually making product improvements. In doing so, we reserve the right to make changes and/or add improvements to our products without obligation for the equipment previously sold.

Modifications to this 6105 Grinder Mixer may affect the performance, function, and safety of its operation. Therefore, no modifications are to be made without the written permission of Art's-Way Manufacturing Co., Inc. Any modification made without the written permission of Art's-Way Mfg. Co. shall void the warranty of this product.

In the interest of continued safe operation of this 6105 Grinder Mixer, pay particular attention to the safety alert symbol(s) throughout this Manual.

### **ART'S-WAY MANUFACTURING CO., INC. STATEMENT OF PRODUCT LIABILITY**

Art's-Way Manufacturing Co., Inc. recognizes its responsibility to provide customers with a safe and efficient product. Art's-Way Manufacturing Co., attempts to design and manufacture its products in accordance with all accepted engineering practices effective at the date of design. This statement should not be interpreted to mean that our products will protect against the user's own carelessness or failure to follow common safety practices nor will Art's-Way Manufacturing Co., be liable for any such act. In addition, Art's-Way Manufacturing Co. assumes no liability for any altered product or any modified product by users or anyone other than an authorized dealer.

### **IMPORTANT WARRANTY INFORMATION**

The warranty for this 6105 Grinder Mixer appears **on page 3** of this Manual. In order to establish proper warranty registration, the Warranty Registration must be completed and returned to the factory. Failure to comply with this requirement may result in reduced warranty allowances.

### **LIMITATIONS OF THIS MANUAL**

This Manual contains operating instructions for your 6105 Grinder Mixer only. Any mention of other machinery in this manual other than the 6105 Grinder Mixer is for reference only. This manual does not replace nor is it to be used for any machinery that may be attached to or used in conjunction with the 6105 Grinder Mixer.

# PARTS & SERVICE

As the purchaser of your new 6105 Grinder Mixer, it is very important to consider the following factors:

- A. Original Quality**
- B. Availability of Service Parts**
- C. Availability of Adequate Service Facilities**

Art's-Way Manufacturing Co., Inc. has an excellent dealership network ready to answer any questions you may have about your 6105 Grinder Mixer. Parts for your machine may be ordered through our dealers. When placing a parts order, please have the **model** and **serial number** ready. This will allow the dealer to fill your order as quickly as possible.

For your convenience, we have provided this space for you to record your model number, serial number, and the date of purchase, as well as your dealer's name and address.

Owner's Name: \_\_\_\_\_

Owner's Address: \_\_\_\_\_

Purchase Date: \_\_\_\_\_

Dealership Name: \_\_\_\_\_

Dealership Address: \_\_\_\_\_

Dealership Phone No.: \_\_\_\_\_

### 6105 Grinder Mixer Serial Number Location

The placard containing the serial and model number is located on the front left-hand side of the 6105 grinder mixer. Enter the serial and model number of your 6105 grinder mixer within the space provided.



Figure 2 - Serial Number Placard.



Figure 1 - Serial Number Placard Location. Left front tank support.

## TABLE OF CONTENTS

<b>TO THE OWNER</b> .....	<b>1</b>	MAIN DRIVE BELTS .....	<b>32</b>
SPECIFICATIONS AND DESIGN ARE SUBJECT TO CHANGE WITHOUT NOTICE.....	1	HAMMERMILL DOOR.....	33
ART'S-WAY MANUFACTURING Co., INC. STATEMENT OF PRODUCT LIABILITY .....	1	MANUAL UNLOADING AUGER SWING CRANK ADJUSTMENT FOR SPROCKET ENGAGEMENT.....	34
IMPORTANT WARRANTY INFORMATION.....	1	MANUAL UNLOADING AUGER SWING BRAKE ADJUSTMENT .....	34
LIMITATIONS OF THIS MANUAL .....	1	MANUAL LIFT ADJUSTMENT .....	34
<b>PARTS &amp; SERVICE</b> .....	<b>2</b>	LIFT ASSIST SPRING ADJUSTMENT .....	34
<b>TABLE OF CONTENTS</b> .....	<b>3</b>	DISCHARGE AUGER LIFT CYLINDER ADJUSTMENT .....	34
<b>SAFETY FIRST</b> .....	<b>6</b>	HYDRAULIC SWING ADJUSTMENT .....	36
NOTICES OF DANGER, WARNING, AND CAUTION .....	6	SWIVEL STOP.....	36
<b>SAFETY GUIDELINES</b> .....	<b>7</b>	SWIVEL STOP ADJUSTMENT .....	37
BEFORE OPERATING .....	7	OPEN AND CLOSED HYDRAULICS .....	37
DURING OPERATION .....	7	CONVERTING TO CLOSED CENTER HYDRAULICS.....	37
MAINTENANCE SAFETY .....	7	POSITIONING THE UNLOADING AUGER TO THE OPPOSITE SIDE OF THE MACHINE .....	37
HYDRAULIC SAFETY .....	8	WHEEL BEARINGS .....	38
TRANSPORTATION SAFETY .....	8	<b>LUBRICATION</b> .....	<b>39</b>
STORAGE SAFETY .....	8	PTO DRIVELINE .....	39
TIRE SAFETY .....	8	HAMMERMILL SHAFT BEARINGS .....	39
ASSEMBLY SAFETY.....	8	HAMMERMILL ENGAGING PIN .....	39
<b>SAFETY DECALS</b> .....	<b>10</b>	DRIVE SHAFT BEARINGS .....	41
DECAL LOCATIONS & IDENTIFICATION .....	10	CHAINS.....	41
<b>INTRODUCTION</b> .....	<b>14</b>	GEARBOX .....	42
<b>PREPARING THE GRINDER MIXER FOR OPERATION</b> .....	<b>16</b>	LOWER VERTICAL MIXING AUGER.....	42
TIRES.....	17	UPPER VERTICAL MIXING AUGER .....	42
GUARDS, DOORS, AND SHIELDS .....	17	UNLOADING AUGER CLUTCH.....	42
BOLTS AND NUTS .....	17	SWIVEL CLAMP.....	42
PREPARING THE TRACTOR.....	18	ELBOW .....	43
TRACTOR HITCH .....	18	HYDRAULIC LIFT .....	43
ATTACHING TO THE TRACTOR .....	18	RING AND WORM GEAR (MECHANICAL) .....	43
HAMMERMILL .....	19	WHEELS .....	44
BEFORE GRINDING .....	19	<b>SERVICE</b> .....	<b>45</b>
DETACHING FROM THE TRACTOR .....	19	TORQUE SPECIFICATIONS .....	45
<b>OPERATION OF GRINDER MIXER</b> .....	<b>21</b>	SHEAR BOLTS .....	45
TRACTOR PTO ENGAGEMENT .....	21	SPROCKET AND CHAIN ALIGNMENT .....	45
HAMMERMILL CLUTCH PIN.....	21	REPLACEMENT OF WORN OR DAMAGED HAMMERS .....	46
FEED GATE .....	21	REVERSING THE HAMMERS .....	46
HAY RETARD BOLTS.....	21	MAIN DRIVE BELT REPLACEMENT.....	46
HAMMERMILL SCREENS .....	22	<b>TROUBLESHOOTING GUIDE</b> .....	<b>48</b>
CHANGING SCREENS .....	23	<b>ATTACHMENTS</b> .....	<b>50</b>
PROCESSING HAY .....	24	ELECTRIC ACTUATOR OPTION.....	50
PROCESSING WITHOUT MIXING .....	24	<i>Preparing the Tractor</i> .....	50
ADDING CONCENTRATE OR SUPPLEMENT.....	24	<i>Preparing the Grinder Mixer</i> .....	50
FILLING THE MIXER TANK .....	26	ELECTRONIC SCALE ATTACHMENT .....	51
SPRING LOADED TANK LID .....	26	ADJUSTABLE SCALE ARM ATTACHMENT .....	51
UNLOADING AUGER POSITIONING .....	27	DISCHARGE UNLOADING AUGER EXTENSIONS .....	51
UNLOADING AUGER ENGAGEMENT .....	27	SCREENS.....	51
UNLOADING CLUTCH DRIVE.....	28	HYDRAULIC ROLL FEED.....	51
FOLDING AUGER EXTENSION .....	28	ROLL FEED ADJUSTMENT .....	52
UNLOADING AUGER HOOD .....	29	<b>SPECIFICATIONS</b> .....	<b>54</b>
AUGER FEED OPERATION .....	29	TANK AND FRAME .....	54
<b>GRINDER MIXER ADJUSTMENTS</b> .....	<b>32</b>	DISCHARGE AUGER .....	54
DRIVE CHAIN ADJUSTMENTS .....	32	AUGER FEEDER.....	54
MAIN DRIVE CHAIN.....	32	MIXING AUGER .....	54
		SUPPLEMENT HOPPER .....	54
		HAMMERMILLS.....	54
		<b>SAFETY DECALS</b> .....	<b>55</b>

DECAL LOCATIONS & IDENTIFICATION .....	55	MANUAL UNLOADING AUGER SWING BRAKE ADJUSTMENT .....	79
<b>INTRODUCTION.....</b>	<b>58</b>	MANUAL LIFT ADJUSTMENT.....	79
<b>PREPARING THE CATTLEMAX FOR OPERATION.....</b>	<b>60</b>	HYDRAULIC SWING DRIVE ADJUSTMENT.....	79
TIRES.....	60	HYDRAULIC SWING SPEED ADJUSTMENT.....	80
SHIELDS.....	60	LIFT ASSIST SPRING ADJUSTMENT.....	80
BOLTS AND NUTS.....	60	POSITIONING THE UNLOADING AUGER TO OPPOSITE SIDE OF MACHINE.....	81
PREPARING THE TRACTOR.....	61	SWIVEL STOP ADJUSTMENT.....	81
TRACTOR HITCH.....	61	OPEN AND CLOSED HYDRAULICS.....	81
ATTACHING TO THE TRACTOR.....	61	CONVERTING TO CLOSED CENTER HYDRAULICS.....	82
ROLLERMILL.....	62	WHEEL BEARINGS.....	82
BEFORE PROCESSING.....	62	<b>LUBRICATION.....</b>	<b>83</b>
DETACHING FROM THE TRACTOR.....	62	PTO DRIVELINE.....	83
<b>OPERATION OF CATTLEMAXX.....</b>	<b>64</b>	GRAIN CONTROL GATE.....	83
TRACTOR PTO ENGAGEMENT.....	64	ROLL BEARINGS.....	83
PROCESSING.....	64	ECCENTRIC BEARING HOUSINGS.....	83
ROLLERMILL.....	64	AGITATOR SHAFT BEARINGS.....	84
DRIVELINE PROTECTION.....	65	ROLLERMILL BELT DRIVE.....	84
HOPPER MAGNETS.....	65	HOPPER MAGNETS.....	84
GRAIN CONTROL GATE.....	65	CHAINS.....	84
ROLL GAP.....	65	GEARBOX.....	85
ROLLERMILL ROLLS.....	66	LOWER VERTICAL MIXING AUGER.....	85
ROLL SELECTION.....	67	UPPER VERTICAL MIXING AUGER.....	85
ROLL SPEED DIFFERENTIAL.....	67	TANK VENT.....	85
ROLL SCRAPERS.....	67	UNLOADING AUGER CLUTCH.....	85
PROCESSING WITHOUT MIXING.....	67	SWIVEL CLAMP.....	86
ADDING CONCENTRATE OR SUPPLEMENT.....	67	ELBOW.....	86
FILLING THE MIXER TANK.....	68	RING AND WORM GEAR (MECHANICAL).....	86
SPRING LOADED TANK LID.....	70	WHEELS.....	87
UNLOADING AUGER POSITIONING.....	70	<b>SERVICE.....</b>	<b>88</b>
<i>Manual Crank.....</i>	<i>71</i>	TORQUE SPECIFICATIONS.....	88
<i>Tractor Hydraulic Lift and Swing.....</i>	<i>71</i>	SHEAR BOLTS.....	88
UNLOADING AUGER ENGAGEMENT.....	71	SPROCKET AND CHAIN ALIGNMENT.....	88
UNLOADING CLUTCH DRIVE.....	71	REPLACEMENT ROLLS.....	89
FOLDING AUGER EXTENSION.....	72	ROLL REPLACEMENT.....	89
UNLOADING AUGER HOOD.....	73	<b>TROUBLESHOOTING GUIDE.....</b>	<b>90</b>
AUGER FEED OPERATION.....	74	<b>ATTACHMENTS.....</b>	<b>92</b>
<b>GRINDER MIXER ADJUSTMENTS.....</b>	<b>77</b>	ELECTRONIC SCALE ATTACHMENT.....	92
DRIVE CHAIN ADJUSTMENTS.....	77	ADJUSTABLE SCALE ARM ATTACHMENT.....	92
MAIN DRIVE CHAIN.....	77	DISCHARGE UNLOADING AUGER EXTENSIONS.....	92
ROLL SPEED DIFFERENTIAL.....	77	<b>SPECIFICATIONS.....</b>	<b>93</b>
ROLL GAP.....	77	<b>ART'S-WAY MANUFACTURING CO., INC. TECHNICAL MANUALS.....</b>	<b>94</b>
ROLL PARALLELISM.....	78		
ROLL SCRAPERS.....	78		
MANUAL UNLOADING AUGER SWING CRANK ADJUSTMENT FOR SPROCKET ENGAGEMENT.....	79		



## SAFETY FIRST

***“A careful operator is the best insurance against an accident”***

(National Safety Council)

Most accidents can be prevented if the operator:

- Fully understands how the machine functions
- Can anticipate situations which may produce problems
- Can make necessary corrections before problems develop



**THIS SYMBOL MEANS  
ATTENTION!  
BECOME ALERT!  
YOUR SAFETY IS INVOLVED!**

**Figure 3 - Universal Safety Alert Symbol.**

The American Society of Agricultural Engineers has adopted the Universal Safety Alert Symbol as a way to identify areas of potential danger if the equipment is not operated correctly. (See Figure 3.) Please be alert whenever you see this symbol in the manuals or on your Grinder Mixer.

Art's-Way Manufacturing Co., Inc. strives to make our equipment as safe as possible. The Art's-Way 6105 Grinder Mixer conforms to applicable safety standards at the time of manufacturing. A safety conscious equipment operator makes an effective accident-prevention program complete.

Safety features and instructions for the Grinder Mixer are detailed in the section of this Operator's Manual. It is the responsibility of the owner to ensure that all operators read and understand the manual before they are allowed to operate the Grinder Mixer. (Occupational Safety and Health Administration (OSHA) regulations 1928.57.)

### **NOTICES OF DANGER, WARNING, AND CAUTION**

Signal Words: Note the use of signal words **DANGER**, **WARNING**, and **CAUTION** on the Grinder Mixer and in this manual. The appropriate signal word for each has been selected using the following guidelines:



**DANGER: IMMEDIATE AND SPECIFIC HAZARD WHICH WILL RESULT IN SEVERE PERSONAL INJURY OR DEATH IF PROPER PRECAUTIONS ARE NOT TAKEN.**



**WARNING: SPECIFIC HAZARD OR UNSAFE PRACTICE COULD RESULT IN SEVERE PERSONAL INJURY OR DEATH IF PROPER PRECAUTIONS ARE NOT TAKEN.**



**CAUTION: A REMINDER OF GOOD SAFETY PRACTICES. PERSONAL INJURY COULD RESULT IF PROPER PROCEDURES ARE NOT FOLLOWED.**





## SAFETY GUIDELINES



**Remember:**

***“The Best Operator is a Safe Operator”***



**CAUTION: READ AND UNDERSTAND THE OPERATOR'S MANUAL AND ALL THE SAFETY DECALS BEFORE OPERATING THE GRINDER MIXER. REVIEW ALL SAFETY INSTRUCTIONS WITH ALL OPERATORS ANNUALLY.**

### BEFORE OPERATING

- Do not wear loose fitting clothing as it may catch in moving parts.
- Make sure to install and/or secure all guards, doors and shields, including the tractor power take-off (PTO) master shield, before starting or operating the Grinder Mixer.
- Be sure that the correct implement driveline parts are used and that they are properly secured.
- Install the safety chain when attaching the Grinder Mixer to the tractor.
- Clear the area of bystanders, especially children, when making repairs, adjustments or performing maintenance on the Grinder Mixer.
- Do not allow riders.
- Put all tractor and machine controls in “neutral” and disengage the PTO before starting. Follow the starting instructions according to your tractor Manual.
- Operate the Grinder Mixer only while seated on the tractor seat.
- Make sure the unit is adequately supported with safety blocks or safety stands when changing tires or performing maintenance.



**CAUTION: KEEP WELL CLEAR OF MOVING PARTS. BE SURE TO SHUT OFF THE TRACTOR AND SET THE PARKING BRAKE. REMOVE THE TRACTOR KEY WHILE MAKING ANY ADJUSTMENTS. WAIT FOR ALL MOVEMENT TO STOP BEFORE APPROACHING THE MACHINE.**

### DURING OPERATION

- Keep hands, feet, hair, and clothing away from moving parts.
- Keep all guards, doors and shields in place and in good working condition.

- Keep all bystanders, especially children, away from the grinder mixer while in operation.
- Do not allow riders while the grinder mixer is in operation.
- Do not attempt to unclog, clean, or adjust the grinder mixer while it is running.
- Stay away from overhead power lines. Electrocutation can occur even without direct contact.
- Keep all hydraulic lines, fittings, and couplers tight and free of leaks. (Refer to - Hydraulic Safety.)
- Use caution when ascending or descending on the grinder mixer. Wet shoes or boots are slippery.

### MAINTENANCE SAFETY

- Follow all operating, maintenance and safety instructions found in this Manual.
- Before servicing, adjusting, repairing or unclogging the machine, always make sure the tractor engine is stopped, the parking brake is set, and all the moving parts have stopped.
- Use sufficient tools, jacks, and hoists that have the capacity for the job.
- Use support blocks or safety stands when changing tires or performing maintenance.
- Follow good shop practices of keeping the service area clean and dry and use adequate light for the job at hand.
- Before applying pressure to the hydraulic system, make sure all lines, fittings and couplers are tightly secured and in good condition.
- Make sure all guards, doors and shields are in place and properly secured when performing maintenance.

**HYDRAULIC SAFETY**

- Make sure components in the hydraulic system are kept clean and in good working condition.
- Relieve pressure from the hydraulic system before servicing or disconnecting from the tractor.
- Keep all hydraulic lines, fittings, and couplers tightly secured and free of leaks.
- Replace any worn, cut, abraded, flattened or crimped hoses.
- Do not make any temporary repairs to the hydraulic lines, fittings or hoses using tape, clamps, or cement. The hydraulic system operates under extremely high pressure and temporary repairs may fail suddenly and create a hazardous and or dangerous situation.
- Wear proper hand and eye protection when searching for a high-pressure hydraulic leak. Use a piece of wood or cardboard as a backstop instead of hands to identify and isolate a leak. If injured by a concentrated high-pressure stream of hydraulic fluid, seek medical attention immediately. Serious infection or toxic reaction can develop if hydraulic fluid penetrates the surface of the skin.
- Before applying pressure to the system, make sure all components are tight and that the hydraulic lines, hoses, and couplings are not damaged.

**TRANSPORTATION SAFETY**

- Make sure the grinder mixer complies with all local regulations regarding the transportation of equipment on public roads and highways.
- Make sure the Slow Moving Vehicle (SMV) emblem and all lights and reflectors required by local highway and transportation authorities are properly in place, clean, and clearly visible to traffic.
- Do not allow riders on any machinery during transport.
- Make sure the grinder mixer is securely attached to the tractor and install a safety chain to the grinder mixer.
- Make sure the tractor brake pedals are latched together.
- Do not exceed 20 mph (32 km/h) when transporting the grinder mixer. Always reduce speed on rough roads and surfaces, or when going down inclines.
- Use caution when turning and always use the turn signals on the tractor to indicate your turning intentions to the other traffic.

- The weight of the trailed machine should NEVER exceed the weight of the towing vehicle.
- Check all clearances carefully whenever the machine is towed.
- Lower the elevator into the transport position before transporting the harvester on the highway.
- Stay away from overhead obstructions and power lines during transport. Electrocutation can occur even without direct contact.

**STORAGE SAFETY**

- Store the grinder mixer in an area away from human activity.
- Do not permit children to play on or around the stored machine at any time.
- Make sure that the grinder mixer is stored in an area with a firm and level base to prevent the machine from tipping or sinking into the ground.
- Block the wheels to prevent the machine from rolling.

**TIRE SAFETY**

- Have only a qualified tire dealer or tire repair service perform tire repairs.
- Do not attempt to install a tire on a wheel or rim unless you have the proper equipment and experience to do the job.
- Follow proper procedures when installing a tire on a wheel or rim to prevent an explosion that could result in serious injury.
- Do not substitute tires with a lesser road rating and/or capacity for the original equipment tires.



**CAUTION: FAILURE TO FOLLOW PROPER PROCEDURES WHEN INSTALLING A TIRE ON A WHEEL OR RIM CAN PRODUCE AN EXPLOSION THAT MAY RESULT IN SERIOUS INJURY OR DEATH. DO NOT ATTEMPT TO INSTALL A TIRE UNLESS YOU HAVE THE PROPER EQUIPMENT AND EXPERIENCE TO PERFORM THE JOB. REPLACEMENT, REPAIR, AND/OR MAINTENANCE SHOULD BE DONE BY A QUALIFIED TIRE DEALER OR QUALIFIED REPAIR SERVICE.**

**ASSEMBLY SAFETY**

- Use adequate manpower to perform assembly procedures safely.
- Assemble the grinder mixer in an area with sufficient space to maneuver the largest

components and allow easy access to all sides of the machine.

- Use only forklifts, lift cranes, jacks and tools with sufficient capacity for the loads.
- Do not allow spectators, especially children, in the working area.

***Remember:***

***"The Best Operator is a Safe Operator"***

## SAFETY DECALS

### DECAL LOCATIONS & IDENTIFICATION

The different types of safety decals for your 6105 Grinder Mixer are illustrated on the following pages. Please familiarize yourself with the appearance of each decal, the warning it describes, and the area where it is located on the grinder mixer. (See Figure 4 and Figure 5)

Safety awareness is the responsibility of each operator of the grinder mixer. Keep safety decals and signs clean and legible and be sure replacement parts display the current safety decals and signs as well.

**Remember: Always replace missing, damaged or illegible safety decals. New decals and signs are available from an authorized dealer.**

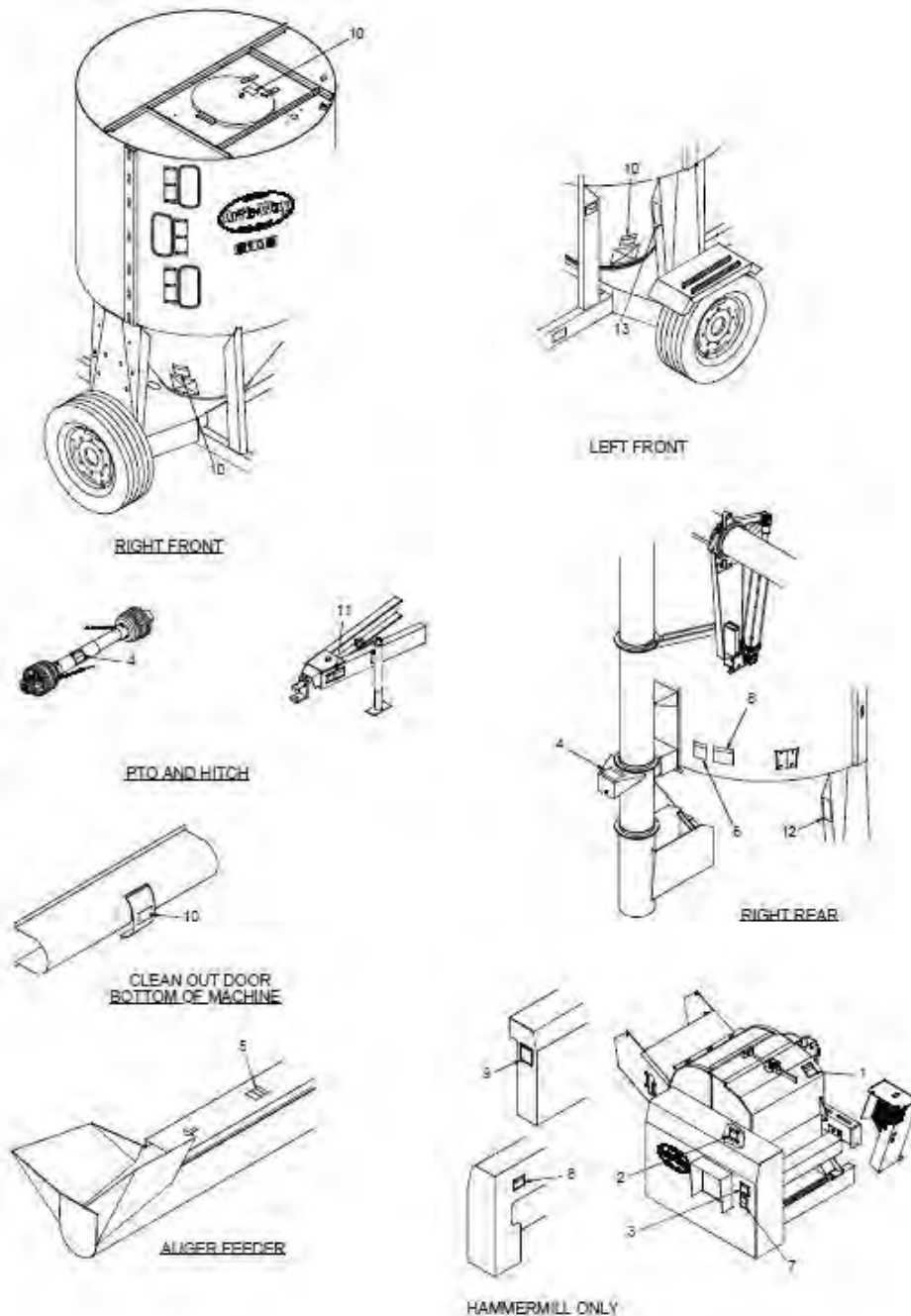

Figure 4 - Safety Decal Locations.

<u>ITEM</u>	<u>PART NO.</u>	<u>QTY</u>	<u>DESCRIPTION</u>
1	363000	1	DECAL, DANGER ROTATING MECHANISM
2	467430	2	DECAL, DANGER SHIELD MISSING
3	384030	1	DECAL, DANGER 540 RPM PTO
4	268860	1	DECAL, DANGER ROTATING DRIVELINE
5	383990	1	DECAL, DANGER AUGER FEEDER HAZARD
6	384000	1	DECAL, DANGER ELECTROCUTION HAZARD
7	368350	1	DECAL, WARNING MOVING FLYWHEEL HAZARD
8	467450	4	DECAL, WARNING MOVING PART HAZARD
9	368040	1	DECAL, CAUTION SAFETY INSTRUCTIONS
10	377280	4	DECAL, CAUTION DO NOT OPEN
11	383970	1	DECAL, CAUTION HITCH INSTRUCTIONS
12	476450	2	TAPE, RED RETRO-REFLECTIVE
13	476460	1	TAPE, YELLOW RETRO-REFLECTIVE

**NOTE:** Keep all decals clean and free of dirt for maximum visibility. Replace all individual decals that are no longer legible. Read and obey all safety decals and be familiar with their meaning.



1. DANGER - Rotation Mechanism (363000)



3. DANGER - 540 RPM PTO (384030)



5. DANGER - Rotating Driveline (268860)



2. DANGER - Shield Missing (467430)



4. DANGER - 1000 RPM PTO (384020)



6. DANGER - Auger Feeder Hazard (383950)

Figure 5a - Safety Decals.



7. DANGER – Electrocutation Hazard (384000)



8. WARNING – Moving Flywheel Hazard (368350)



9. WARNING – Moving Part Hazard (467450)



10. CAUTION – Safety Instructions (368040)



11. WARNING –High Pressure Fluid Hazard (346310)



12. CAUTION – Do Not Open (377280)

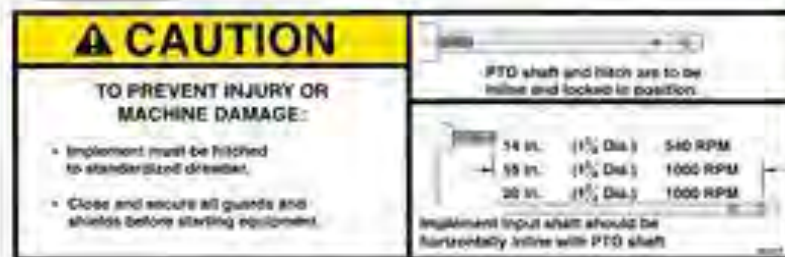

13. CAUTION – Hitch Instructions (383970)

Figure 5b – Safety Decals

**NOTE:** Keep all decals clean and free of dirt for maximum visibility. Replace all individual decals that are no longer legible. Read and obey all safety decals and be familiar with their meaning.

## INTRODUCTION

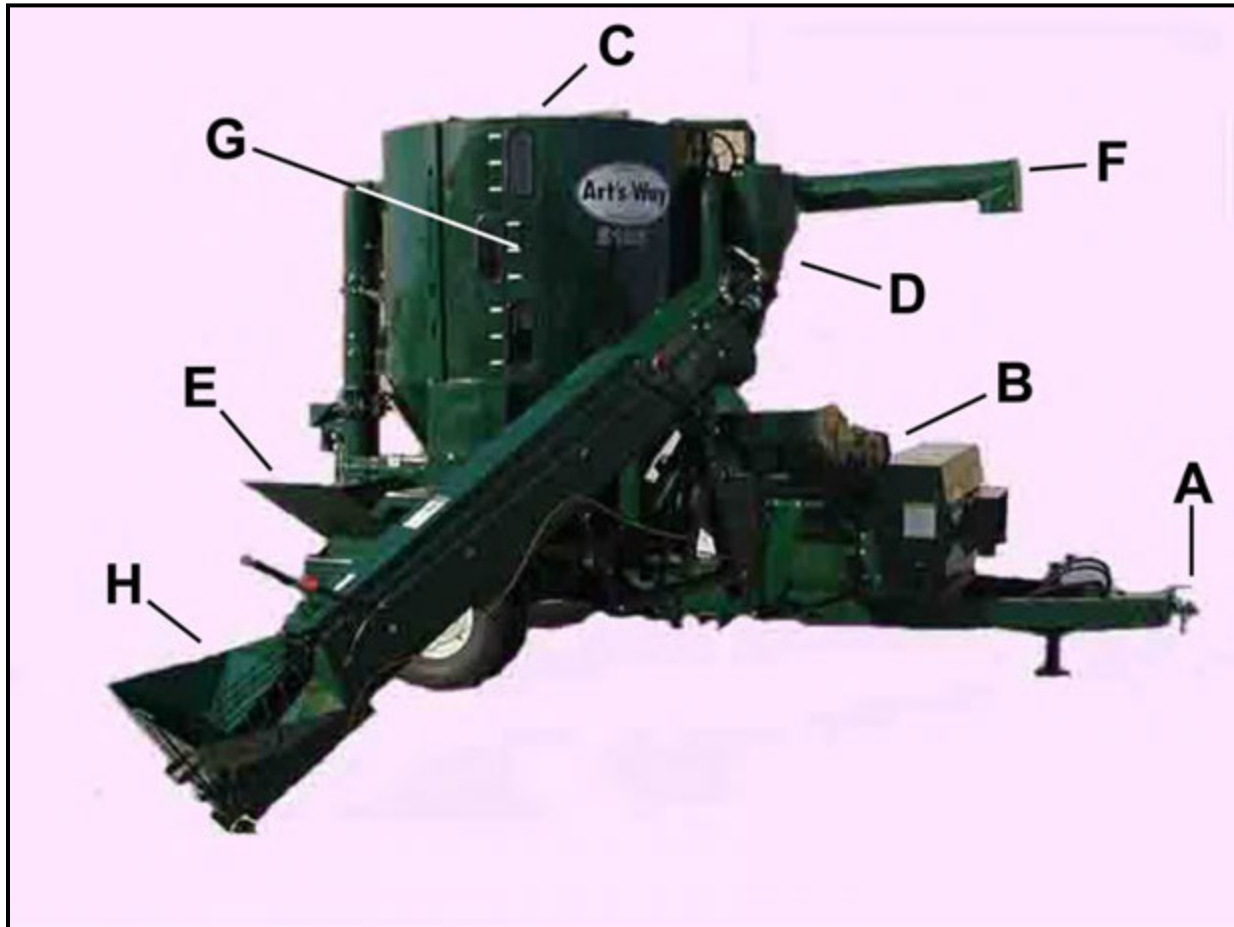

Figure 6 - Model 6105 With Auger Feeder (A – PTO Driveline; B – Hammermill; C – Mixing Tank; D – Dust Collector; E – Supplement Hopper; F – Unloading Auger; G – Viewing Windows; H – Auger Feeder).

This manual has been prepared to make you familiar with the proper operation, adjustment, lubrication and service of your grinder mixer. Take time to be careful and better understand the efficient operation and care of your machine.

Whenever the terms “Left” and “Right” are used, it should be understood to mean standing behind the machine and facing the direction of forward travel.

**Some pictorials are used to show guards, doors and shields removed for easy identification. Make sure that all guards, doors and shields are in place before operating the machine. They are for your protection.**

The Art’s-Way 6105 Grinder Mixer is driven by a PTO driveline of 40 hp to 150 hp tractors. (Figure 6, Detail A) When using tractors over 150 hp, limit input. It is available only with a 540 RPM drive.

Hammermill respective speed should be maintained as the hammermill cylinder operates best at 2800 to 3000 RPM. (Figure 6, Detail B) Hammermill cylinder must not exceed 3000 PRM.



**CAUTION: NEVER OPERATE A 540 RPM PROCESSOR WITH A 1000 RPM TRACTOR.**

Before operating your grinder mixer, select and install the screen size desired. Sizes are available from 1/8 to 2 inch openings. For screen selection guidelines, refer to OPERATION OF GRINDER MIXER - Hammermill Screens.

All types of grain can be ground with the hammermill. Hay can be ground with a minimum of 1/3 mixer of grain. Material is fed into the hammermill where it is ground until it can pass through the screen size selected. From the hammermill, the material is augered into the mixing tank. (Figure 6, Detail C) A suction fan takes air pressure out of the hammermill housing and delivers feed fines into the dust collector. (Figure 6, Detail D) The fines are separated and then dropped into the mill to mixer auger.



If supplement is to be added to the ration, a hopper with a sack cutter is located at the right rear of the mixing tank. (Figure 6, Detail E (Not Shown) – Supplement Auger) The best mixing will result if the supplement is added before grinding.

The ground feed is mixed continuously until the tractor PTO is disengaged.

The unloading auger pivots at the rear center of the mixing tank and can swing 316 degrees on the grinder mixer in a horizontal arc. (Figure 6, Detail F) It can also swing in a vertical arc to the limit of the lift cylinder. The unloading auger tube can be positioned either to the right or to the left side of the tank for transport. For procedure instructions, refer to GRINDER MIXER ADJUSTMENTS - Positioning The Unloading Auger To The Opposite Side Of The Machine. Unloading rates up to 30 bushels per minute can be obtained depending upon position of the discharge and the type of material processed.

Three viewing windows are located at the front right corner of the mixing tank to observe the feed level during grinding and mixing. One viewing window is located in the back of the tank for added viewing of feed level. (Figure 6, Detail G.) A ladder is located at the front left corner of the mixing tank along with a handle on top of the tank to gain access to the spring-loaded mixing tank lid.



**CAUTION: DO NOT OPEN SPRING-LOADED MIXING TANK LID WHILE PTO IS ENGAGED AND TRACTOR IS RUNNING.**

Many convenient features are standard equipment on the Art's Way 6105 grinder mixer including:

**105 bu. – 6105**

1. 10.00 x 15 tires.
2. Magnet in the hammermill throat.
3. Hydraulic or mechanical positioning of discharge auger. This includes a hydraulic cylinder or mechanical crank for lift and hydraulic motor or mechanical crank for swing.
4. Positioner to enable the hopper on the auger feeder to be moved in or out 6 inches to properly position in front of the augers. (Figure 6, Detail H)
5. Fenders.
6. Screen rack.
7. Tongue jack.
8. Discharge auger hood with spring loaded relief door.
9. 540 RPM PTO
10. 72 Hammers.

Below is a list of optional attachments available:

1. Auger feeder (hydraulic). (See Figure 7.)



**Figure 7 - Model 6105 With Auger Feeder.**

2. Electronic scale, with digital readout.
3. Positioning arm for electronic scale box.
4. Horn, light, or horn and light for electronic scale.
5. Unloading auger extensions; 3 ft. or 6 ft. folding or bolt-ons.
6. Hydraulic roll feed in mill throat hammermills.
7. Highway transport light kit.
8. Electric activated discharge.
9. Hydraulic Discharge (Tractor Operated) designated with an H behind model number (i.e. 6105H).

## PREPARING THE GRINDER MIXER FOR OPERATION

Remove the shipping banding or wire from the auger feeder (if equipped), rear discharge cover and the unloading tube to saddle at the side of the tank.

**IMPORTANT:** Remove the bag from the supplement hopper. Place the screen hook in the hammermill door pin. (See Figure 8)

Install the PTO driveline storage bracket under the front hitch with 1/2 inch x 1-1/2 inch bolt and lock nut. (See Figure 9) Maintain tension with the lock nut to allow movement with 15 lbs. pull.

If equipped with auger feeder, remove the transport locking plate. Refer to OPERATION OF GRINDER MIXER - Auger Feed Operation.



Figure 9 - PTO Driveline Storage Bracket.

UNLOADING HEIGHT OBTAINED ON LEVEL SURFACE. 105 Bu. (See Figure 33.)			
Unloading Auger Configuration	Tube & Elbow Combined Length	Discharge 45° 29 Inch Tube	Discharge 60° 29 Inch Tube
Standard – No Extensions	125 Inches	14 ft. 9 in.	16 ft. 8 in.
3 ft. Fold Around Auger Extension	161 Inches	17 ft. 0 in.	19 ft. 3 in.
6 ft. Fold Around Auger Extension	197 Inches	19 ft. 3 in.	22 ft. 0 in.

Install any option that was ordered with the grinder mixer and shipped as loose equipment. See package instructions with the specific options for installation.

Install the implement end of the PTO driveline by fastening it to the input jackshaft with the 5/16 inch x 3-1/2 inch clevis pin and cotter pin provided.

Spread the cotter pin and make sure the proper PTO is used. The 6105 is supplied with 540 RPM only.



**CAUTION: NEVER OPERATE A 540 RPM GRINDER MIXER WITH A 1000 RPM TRACTOR.**

**NOTE:** Height of the unloading auger tube needs to be checked. Move the saddle on the side of the mixing tank so the tube will properly clear the tractor and cab.

If equipped with a tractor hydraulic auger feeder or roll feed, refer to OPERATION OF GRINDER MIXER - Hydraulic Discharge (6105H Models **Only**)

Connect two hydraulic discharge hoses to desired hydraulic circuit on tractor. Hoses come installed with Pioneer™ style male quick connectors from factory (See Figure 31).

Slowly engage the hydraulic discharge with tractor.



Figure 8 - Screen Hook Storage.

Gradually increase speed to at least 2/3 throttle to reduce the risk of bogging machine down or potentially plugging an auger. Open the unloading door slowly. The eccentric may be used to hold the door open (See Figure 30).

When the tank is unloaded, reverse the procedure. Always make sure that discharge is empty before transporting mixer.

Recommended tire inflation pressure is as follows:

10.00 x 15 8 – PR tires – 40 psi

**GUARDS, DOORS, AND SHIELDS**

Make sure that all of the guards, doors, and shields are in place and functioning.

**BOLTS AND NUTS**

Cap screws, except for shear bolts, used on the grinder mixer are Grade 5 and if replaced, cap screws of equal or greater strength should be used. Grade 5 cap screws are identified by three radial dashes on the hex head. Refer to the SAE bolt identification guide. (See Figure 10)

UNLOADING HEIGHT OBTAINED ON LEVEL SURFACE. 105 Bu. (See Figure 33.)			
Unloading Auger Configuration	Tube & Elbow Combined Length	Discharge 45° 29 Inch Tube	Discharge 60° 29 Inch Tube
Standard – No Extensions	125 Inches	14 ft. 9 in.	16 ft. 8 in.
3 ft. Fold Around Auger Extension	161 Inches	17 ft. 0 in.	19 ft. 3 in.
6 ft. Fold Around Auger Extension	197 Inches	19 ft. 3 in.	22 ft. 0 in.

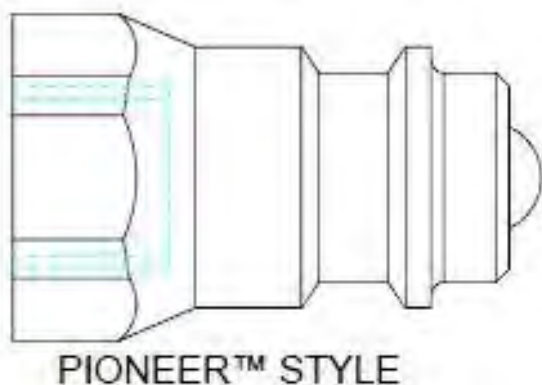

Figure 31 - Hydraulic Quick Connector

Folding Auger Extension,

Table 4 - Unloading Heights.

Unloading Auger Hood, and Auger Feed Operation sections as well as the ATTACHMENTS section for instructions.

**TIRES**

Keep tires properly inflated. Lack of pressure can result in torn valve stems, fabric breaks and uneven tread wear. Too much pressure can cause undue strain on fabric, excessive tread wear and allows the tire to cut in more on wet surfaces. Equal tire pressure reduces grinder mixer sway when towing.

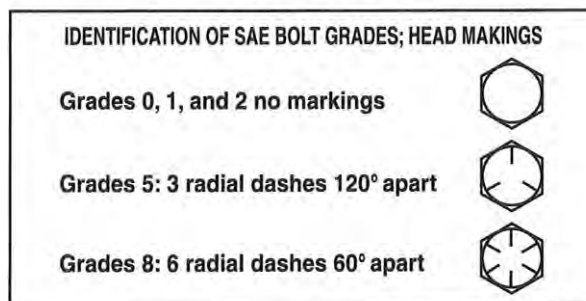

Figure 10 - SAE Bolt Identification.

**IMPORTANT:** Shear bolts must be replaced with bolts of the same grade

Before operation of the grinder mixer, make sure all bolts and nuts are properly tightened. Make sure all cotter pins are spread and not damaged. After operation of the grinder mixer for several hours, make sure all bolts are set to proper torque. Refer to the torque guide. (See Table 1)

Size	Clamp Load	Plain GR 5	Plated GR 5
1/4 – 20 (.250)	2,025	8 ft. lbs.	76 in. lbs.
5/16 – 18 (.3125)	3,338	17 ft. lbs.	13 ft. lbs.
3/8 – 16 (.375)	4,950	31 ft. lbs.	23 ft. lbs.
7/16 – 14 (.4375)	6,788	50 ft. lbs.	37 ft. lbs.
1/2 – 13 (.500)	9,075	76 ft. lbs.	57 ft. lbs.
9/16 – 12 (.5625)	11,625	109 ft. lbs.	82 ft. lbs.
5/8 – 11 (.625)	14,400	150 ft. lbs.	112 ft. lbs.
3/4 – 10 (.750)	21,300	266 ft. lbs.	200 ft. lbs.
7/8 – 9 (.875)	29,475	430 ft. lbs.	322 ft. lbs.
1 – 8 (1.00)	38,625	644 ft. lbs.	483 ft. lbs.
1-1/8 – 7 (1.125)	42,375	794 ft. lbs.	596 ft. lbs.

**Table 1 - Torque Specification Guide For Grade 5 Bolts.**

Lubricate the grinder mixer at regular intervals as instructed in the lubrication sections. (Refer to LUBRICATION section.)

## PREPARING THE TRACTOR

The tractor must be equipped with a 540 RPM PTO to match the grinder mixer as described in the previous section. Make sure the grinder mixer and the tractor are equipped and set for the proper RPM.



**CAUTION: NEVER OPERATE A 540 RPM GRINDER MIXER WITH A 1000 RPM TRACTOR PTO.**

## TRACTOR HITCH

The hitch for the grinder mixer is designed to attach to any SAE – ASAE standardized tractor drawbar. Adjust the drawbar so it is 13 to 17 inches above the ground. (See Figure 11) Extend or shorten the tractor drawbar so the horizontal distance from the end of the tractor PTO shaft to the center of the hitch pin hole is 14 inches for 540 RPM drives.

Lock the drawbar in its crossbar, parallel with the centerline of the PTO. Place locking pins on each side of the drawbar. If the tractor has an offset drawbar, the offset should be down for PTO work.

**IMPORTANT:** An improperly located hitch point may cause damage to the universal joints (U-Joints) of the PTO driveline.

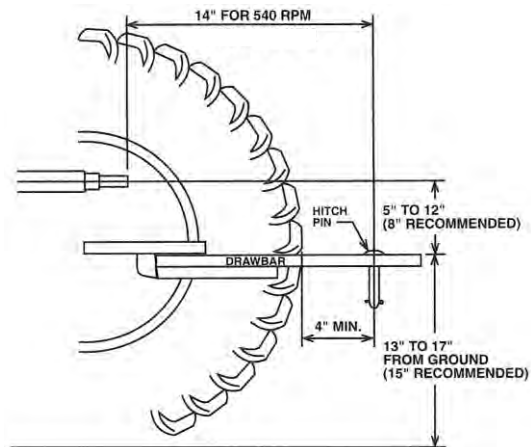

**Figure 11 - Hitch Point Locations**

## ATTACHING TO THE TRACTOR

**NOTE:** Height of the unloading auger tube needs to be checked. Move the saddle on the side of the mixing tank so the tube will properly clear the tractor and cab.

Carefully back the tractor up to the hitch. Use the crank of the jack to raise or lower the grinder mixer hitch into position to engage the tractor drawbar.

Fasten the grinder mixer hitch to the drawbar with a hitch pin that cannot bounce out. Raise the jack and lock into the transport position. (See Figure 12) Attach the safety chain from the grinder mixer to the tractor. (See Figure 13)



**CAUTION: ALWAYS FOLLOW STATE AND LOCAL REGULATIONS REGARDING A SAFETY CHAIN WHEN TOWING FARM EQUIPMENT ON PUBLIC HIGHWAYS.**



**Figure 12 - Jack In Transport Position**



**Figure 13 - Grinder Attached To The Tractor With Safety Chain.**

If the grinder mixer is equipped with an electronic scale, plug the scale power supply cord into the electrical outlet on the tractor or to the battery on the mixer frame.

**IMPORTANT:** On electronic scale applications, if a bolt and nut are used in place of a hitch pin, the nut must not be tightened to where it hits against the underside of the weigh bar clevis.

If the grinder mixer is equipped with a tractor hydraulic function, install the proper male ends on the hoses and plug the hydraulic line hoses into the tractor outlets. (Refer to GRINDER MIXER ADJUSTMENTS - Open And Closed Hydraulics.)

Connect the PTO driveline to the tractor PTO shaft. The PTO operating speed of the tractor and grinder mixer must be the same. The tractor half of the PTO is equipped with 1-3/8-6 splines for 540 RPM operation.

### **HAMMERMILL**

Make sure the grinder mixer is equipped with a 540 RPM drive when operating with a tractor equipped with a 540 RPM PTO drive. The diameter of the pulley on the jackshaft must be 22-5/8 inches for 540 RPM operation in a hammermill application. (See Figure 14)



**CAUTION: NEVER OPERATE A 540 RPM GRINDER MIXER WITH A 1000 RPM TRACTOR.**

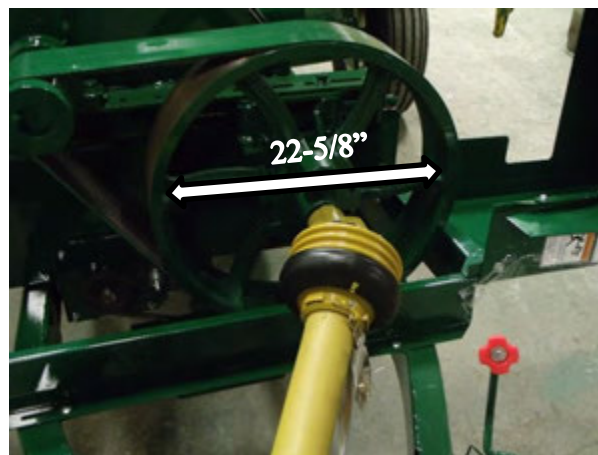

**Figure 14 - Large Pulley - 540 RPM (Shields Removed For Clarity).**

After connecting the PTO driveline to the tractor, anchor the driveline implement shield chain, located in the main shield base slot, and the tractor shield chain to the tractor drawbar.

### **BEFORE GRINDING**

New machines should be operated before preparing feed. A few hundred pounds of coarse material such as shelled corn or ground cobs should be ran through the grinder mixer. This will remove the protective oil coating from the mixer cone and any metal particles that may be in the machine. This will help polish the cone and prevent bridging. After several minutes of running the grinder mixer, unload the mixture and discard. **Do not feed this mixture to the livestock.**

### **DETACHING FROM THE TRACTOR**



**CAUTION: MAKE SURE THE TRACTOR IS SHUT OFF, REMOVE THE KEY AND PLACE THE KEY IN YOUR POCKET.**

Disconnect the PTO driveline and front shield anchor chain from the tractor and place it on the PTO driveline support bracket. (See Figure 15) The PTO driveline support should be tight enough to remain in position when rotated from storage against the frame to use position.

Disconnect the electronic scale power cord from the tractor (if equipped).

Disconnect the hydraulic hoses from the tractor outlets (if equipped with tractor hydraulic functions).

Make sure the discharge auger and the auger feeder are in their saddles before disconnecting.

Block the tires. Lower the jack stand to the ground. Turn the handle of the jack stand to raise the grinder mixer tongue off of the tractor hitch. Remove the hitch pin and safety chain.



Figure 15 - PTO Support.

## OPERATION OF GRINDER MIXER

### TRACTOR PTO ENGAGEMENT

The mixer may be operated by engaging the PTO. Always engage the tractor PTO with the tractor engine at idle speed. After the PTO is engaged, increase the engine speed gradually until the desired operating speed is obtained. Reverse the PTO engagement steps to disengage the PTO.

For smooth PTO operation and to help increase the life of the PTO driveline, make sure the tractor is aligned straight with the frame of the grinder mixer whenever possible.

**IMPORTANT:** If mixing while in transport, avoid sharp and unnecessary turns which may damage the PTO driveline.

### HAMMERMILL CLUTCH PIN



**CAUTION: BEFORE ENGAGING OR DISENGAGING THE CLUTCH PIN, MAKE SURE THE HAMMERMILL HAS COME TO A COMPLETE STOP AND SHUT OFF THE TRACTOR BEFORE PROCEEDING WITH THE NEXT STEP. PLACE THE KEY IN YOUR POCKET.**

The hammermill clutch pin is located on the front of the fly-wheel. (See Figure 16) ***Make sure the grinder mixer has come to a complete stop and shut off the tractor before proceeding with the next step.*** To engage the hammermill, turn the fly-wheel by hand to align one of the six slots in the fly-wheel with the pin. Push in the pin and turn 1/4 turn in either direction to lock it in place. To disengage the hammermill, push in the pin, turn 1/4 turn, and release.



**CAUTION: ALWAYS OPERATE PTO AT THE SAME SPEED FOR WHICH THE GRINDER MIXER IS EQUIPPED; 540 RPM. NOTE THE SPEED DECAL ON THE FRONT SHIELD OF GRINDER MIXER.**

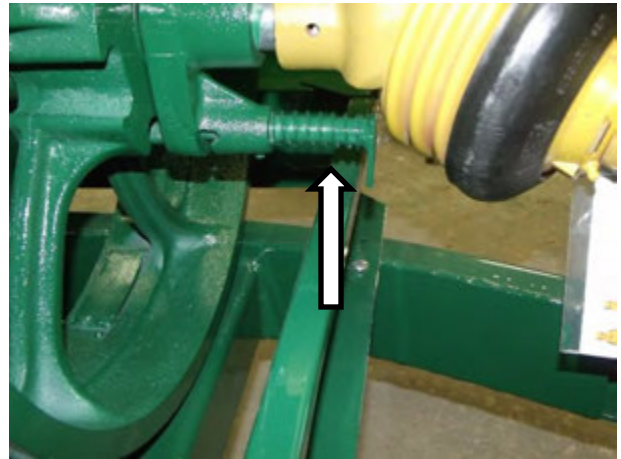

Figure 16 - Hammermill Clutch Pin (Pin Disengaged In Photo And Shields Removed For Clarity).

### FEED GATE

A feed gate is provided in the mill throat with a rubber baffle (removed for roll feed installation) behind it. (See Figure 17) The feed gate should be set to the lowest possible position to allow material to flow into the hammermill evenly.



Figure 17 - Feed Gate At Throat Of The Hammermill.

### HAY RETARD BOLTS

The hay retard bolts will help maintain uniform feeding while grinding hay. (See Figure 18) The degree of the retard is adjusted by loosening the lock nuts on each of the retard bolts and turning the bolts in (increase) or out (decrease) to the desired position. Secure the bolts by tightening the lock nuts.

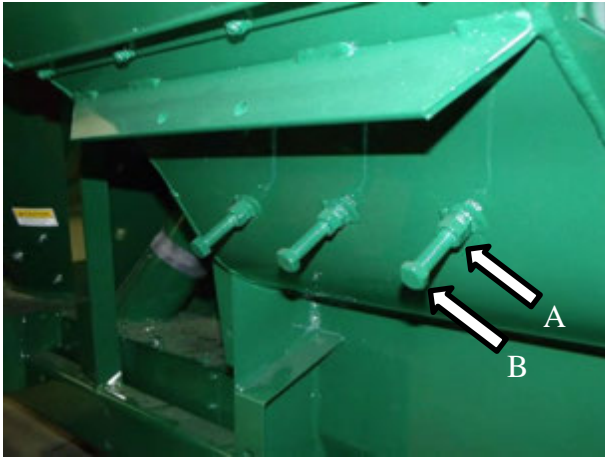
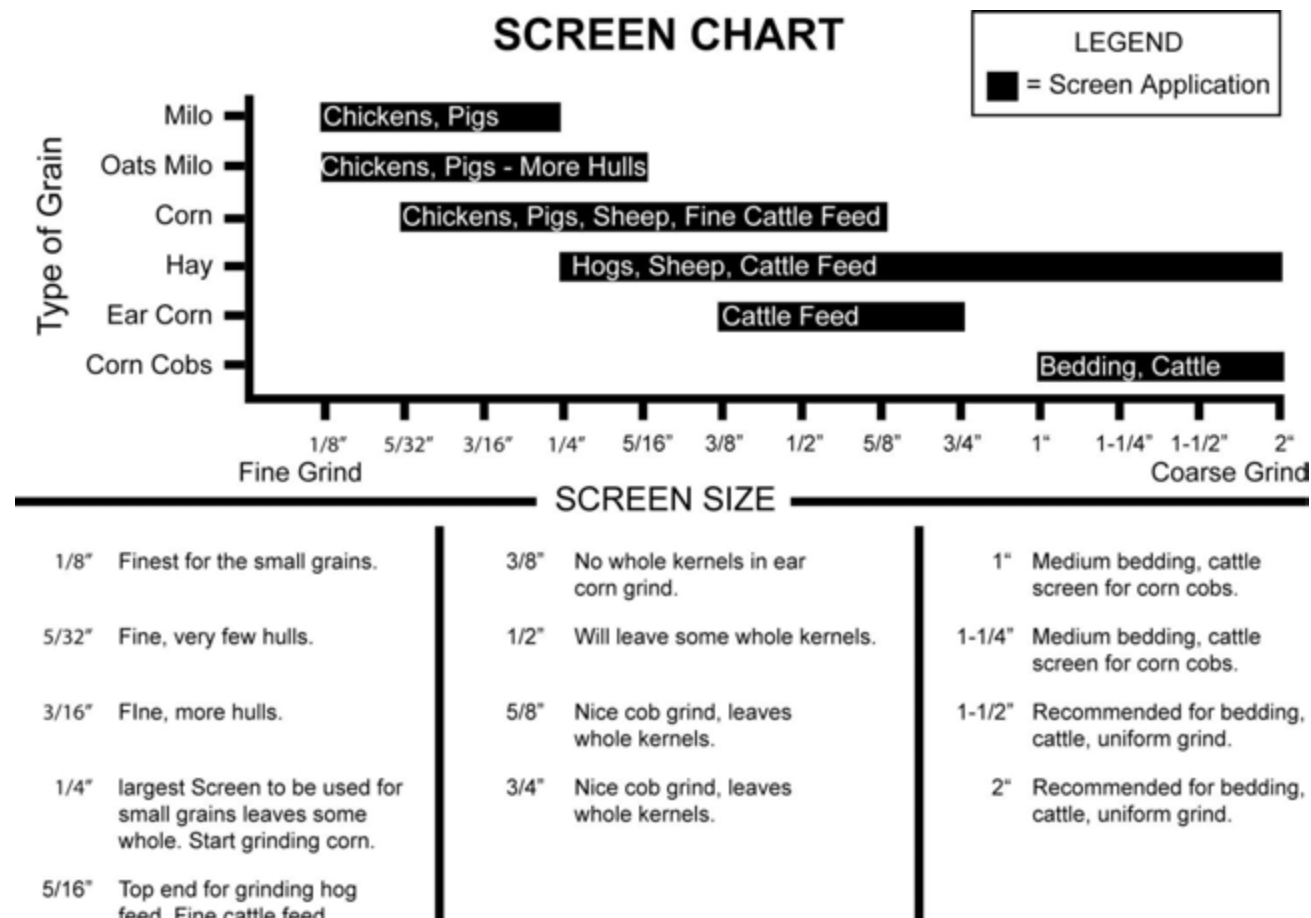

Figure 18 - Hay Retard Bolts (A - Lock Nut; B - Adjustable Retard Bolt).

### **HAMMERMILL SCREENS**

Hammermill screens are available in sizes ranging from 1/8 inch up to 2 inch openings. The screen size needed will be determined by the material and degree of fineness desired.





**Table 2 - Screen Chart.**

The Table showing the screen sizes may be used as a guide for grinding different types of feed. (See Table 2)

Do not use a finer screen than needed as this will require more power and reduce mill capacity. Never grind wet corn or hay. This can cause auger problems during loading and unloading

**CHANGING SCREENS**



**CAUTION: DISENGAGE ALL THE DRIVES. SHUT OFF THE TRACTOR ENGINE AND PLACE THE KEY IN YOUR POCKET BEFORE INSTALLING OR CHANGING HAMMERMILL SCREENS. NEVER OPEN THE HAMMERMILL COVER UNTIL THE HAMMERMILL HAS COME TO A COMPLETE STOP.**

Extra screens are carried in the screen rack located over the left fender.

To install or change the screen, open the hammermill door and remove the screen with the hook provided. (See Figure 19)



**Figure 19 - Changing screens**

The screen support rack will drop down to make the screen removal easier. Install the new screen. Close the hammermill door and then replace the screen hook and locking pins. (See Figure 20)



Figure 20 - Locking Pin and Latch on Hammermill Door (26 Inch Hammermill Shown).

### **PROCESSING HAY**

If hay is to be ground, grind the grain first. Do not grind more than five bales of hay per tank until you are familiar with the results. Large amounts of hay or coarse ground hay can cause *bridging* in the tank and make it difficult to unload. If large quantities of hay are to be ground, run the hay straight through the machine without filling the tank.

### **PROCESSING WITHOUT MIXING**

To grind any material without mixing, engage the unloading auger lever, open the tank unloading auger door and start the grinding operation.

The feed will be augered into the mixing tank cone and then out through the unloading augers without mixing. Position the unloading auger tube as needed to direct the feed.

### **ADDING CONCENTRATE OR SUPPLEMENT**

Concentrate or supplement should be added to the ground feed through the supplement hopper located at the right rear corner of the grinder mixer. (See Figure 21) A serrated sack cutter is located in the hopper opening. A grate is positioned below the sack cutter to keep the bag from falling into the auger.



**CAUTION: KEEP HANDS AND FEET CLEAR OF AUGER. MAKE SURE GRATE IS ALWAYS IN PLACE.**

***For best results, add the concentrate or supplement before grinding operation. Do not add ingredients to the supplement hopper while grinding, this will over load the auger.***



Figure 21 - Supplement hopper located on right hand side of machine

If micro-ingredients are to be added to the feed, the best results are obtained with a pre-mix, or by adding the supplements and micro-ingredients at the same time. If the micro-ingredients are desired without a pre-mix or other supplement, open the mixing tank lid and add the ingredients directly into the mixer. This should be done at the beginning of the operation. Make sure to close the lid before starting the operation. The supplement hopper lid should always be closed when not in use. If strong additives are not desired in the batch that follows, clean out the tank cone and unloading augers through the clean-out doors. (See Figure 22)



**CAUTION: MAKE SURE THE PTO IS DISENGAGED AND THE TRACTOR IS SHUT OFF. PLACE THE KEY IN YOUR POCKET BEFORE OPENING OR CLOSING THE CLEAN-OUT DOOR.**

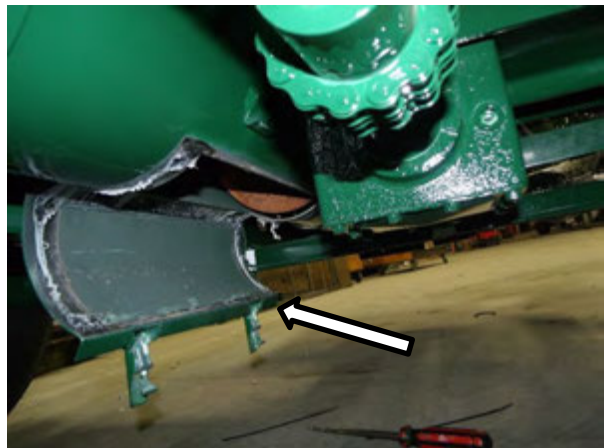

Figure 22 - Cleanout Door Located Under Right Hand Side Of Tank Assembly.

Located under the right hand side frame and tank assembly is a hinged door on the bottom of the auger trough. Release two spring clamps and allow door to drop. Keep away from the opening. Run the mixer slowly until the trough and the mixing tank are

cleaned out. Keep all bystanders away from the machine.

### 105 BU. – APPROXIMATE CAPACITY CALIBRATION – IN POUNDS\*

Actual weights may vary due to material, moisture, and screen size. Ration weight is not included and is variable.

Window Position	Ground Oats 22.5 lbs/bu	Ground Barley 36 lbs/bu	Ground Milo 56 lbs/bu	Ground Shelled Corn 50 lbs/bu	Ground Ear Corn 38 lbs/bu	Un-ground Shelled Corn 56 lbs/bu
Full	2346	3754	5839	5213	3962	5839
9	2219	3549	5521	4930	3747	5521
8	2046	3274	5092	4547	3456	5092
7	1874	2998	4664	4164	3165	4664
6	1659	2654	4129	3687	2802	4129
5	1487	2379	3701	3304	2511	3701
4	1315	2103	3272	2921	2220	3272
3	1100	1760	2737	2444	1857	2737
2	928	1484	2038	2061	1566	2038
1	756	1208	1880	1678	1276	1880

**NOTE:** \* Above weights are approximate and are to be used as a guide only. Variations may occur due to test weight of grain, slope of machine, moisture content, or screen size. For best ration control use an electronic scale.

Table 3 - Approximate Calibration Capacity.

### FILLING THE MIXER TANK

Make sure the mixing tank unloading door is closed. As the mixing tank is filling, watch the ground feed through the mixing tank windows. If the top window is covered, this does not mean the tank is full as the mixing auger throws material away from the center of the tank. Continue loading until the top window clears (feed drops) and then becomes covered again about half-way. (See Figure 23) Stop feeding material into the processor at this point, but continue operating until the processor has had time to clear. *Do not overload the mixer.* An overload can cause damage to the machine. To estimate the number of bushels that are in the tank, refer to Table 3.

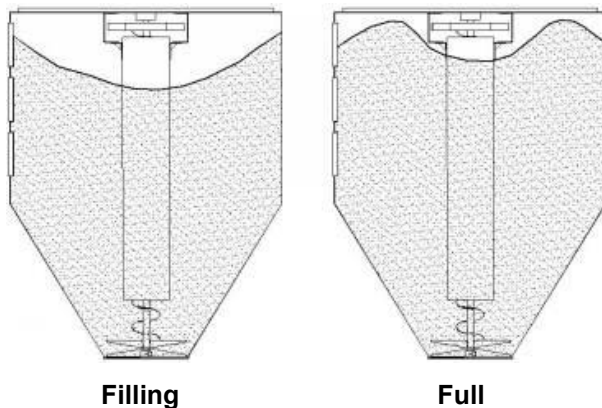

Figure 23 - Filling pattern

For the best mixing results, always add lightweight bulky materials first. Always add high moisture corn or grain last. Excessive amounts of wet or bulky material may cause *bridging* in the mixing tank.

### SPRING LOADED TANK LID



**CAUTION: DISENGAGE ALL THE DRIVES. SHUT OFF THE TRACTOR ENGINE AND PLACE THE KEY IN YOUR POCKET BEFORE OPENING THE MIXING TANK LID.**

If the mixing tank is accidentally overfilled, it is equipped with a spring loaded tank lid. (See Figure 24) The lid also allows access to the inside of the mixing tank. Keep the lid closed and latched at all times.



**CAUTION: IF ENTERING THE TANK, MAKE SURE THE TRACTOR ENGINE IS SHUT OFF. PLACE THE KEY IN YOUR POCKET AND DISCONNECT THE PTO DRIVELINE.**



Figure 24 - Spring Loaded Tank Lid.

After the processing is completed and the desired ration is in the mixing tank, allow the mixer to operate until it is ready to unload. Run the mixer 2 to 3 minutes to ensure the feed and supplements have been thoroughly mixed.

**IMPORTANT:** Avoid sharp and unnecessary turns which may damage the PTO driveline during transport.

### **UNLOADING AUGER POSITIONING**

After mixing, the finished feed may be unloaded into storage bins, wagons, or feeders. Positioning (Lift and Swing) of the unloading auger and drive for the unloading auger may be controlled in two ways.

#### A) Manual Crank

(See Figure 25 and Figure 26)

Insert crank on the shaft next to channel to lift and on the shaft at the rear of lower auger housing to swing the unloading auger. A brake is provided to prevent movement after positioned (See Figure 27)



Figure 25 - Manual Swing

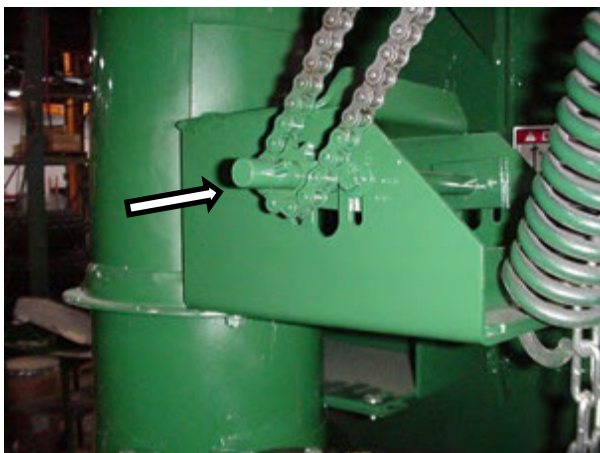

Figure 26 - Manual Lift



Figure 27 - Manual Break

#### B) Tractor Hydraulic Lift And Swing

Hydraulic lift and swing is accomplished by using the hydraulic system valves. If a hydraulic auger feeder is present, a double selector valve is required to direct flow of the hydraulic fluid. Either the swing motor or the auger feeder may be operated independently but not at the same time. (See Figure 28) Position the selector valve control "in" to direct fluid to discharge the swing function. Make sure spool goes fully against the snap ring when moving lever in.



Figure 28 - Hydraulic Selector Valve (Lever in the In Position - Hydraulic Swing).

Connect four hydraulic hoses with the appropriate male connectors to the tractor. Make sure the proper hoses are connected to the same tractor hydraulic circuit. Activate the appropriate tractor valve to lift the unloading auger, then use the other hydraulic valve to swing the unloading auger to the desired position.

### **UNLOADING AUGER ENGAGEMENT**

Operate the tractor at a minimum of 2/3 throttle for unloading.

### **UNLOADING CLUTCH DRIVE**

Starting at an idle, move the clutch handle ahead and down to engage the augers. (See Figure 29) Gradually increase speed to at least 2/3 throttle. Open the unloading door. The eccentric may be used to hold the door open. (See Figure 30) When the tank is unloaded, reverse the procedure.

If equipped with optional electronic actuators, engage the appropriate function. Make sure clutch is fully engaged at the idle speed.

If equipped with optional hydraulic discharge (6105H models), clutch is NOT installed.

**NOTE:** If unloading in more than one location, close the discharge door and empty the auger before transporting the mixer.



Figure 29 - Unloading Clutch Operation.

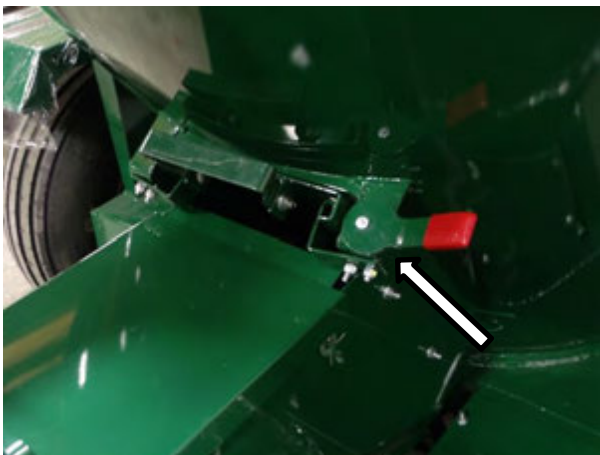

Figure 30 - Unloading Door (A - Eccentric Lock).

### **Hydraulic Discharge (6105H Models Only)**

Connect two hydraulic discharge hoses to desired hydraulic circuit on tractor. Hoses come installed with Pioneer™ style male quick connectors from factory (See Figure 31).

Slowly engage the hydraulic discharge with tractor.

Gradually increase speed to at least 2/3 throttle to reduce the risk of bogging machine down or potentially plugging an auger. Open the unloading door slowly. The eccentric may be used to hold the door open (See Figure 30).

When the tank is unloaded, reverse the procedure. Always make sure that discharge is empty before transporting mixer.

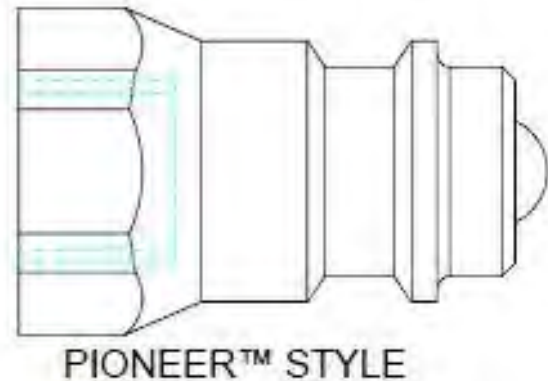

Figure 31 - Hydraulic Quick Connector

### **FOLDING AUGER EXTENSION**

Optional extensions for the unloading auger include a 3 to 6 feet folding or bolt-on extension. (See Figure 32) For discharge heights of the optional extensions. (See Figure 33)

If the grinder mixer is equipped with a folding auger extension, make sure the outer auger drive cog is properly engaged and the extension tube is locked before engaging the unloading clutch.



Figure 32 - Folding Auger Extension. (6' Extension shown)

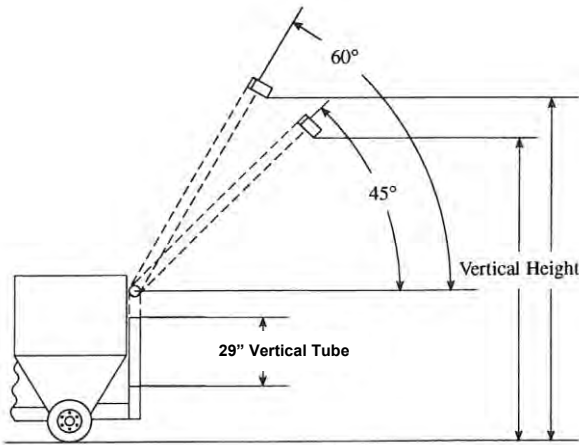

Figure 33 - Unloading Auger Heights (Refer to for Detailed Heights.)

lowered. Lift the auger feeder slightly and pull the rope on the right hand side to disengage the height adjustment ratchet bar. Raise or lower to the desired height and release the rope. Remove the clip pin holding the auger feeder folding hopper up and then swing the hopper down. (See Figure 36)

UNLOADING HEIGHT OBTAINED ON LEVEL SURFACE. 105 Bu. (See Figure 33.)			
Unloading Auger Configuration	Tube & Elbow Combined Length	Discharge 45° 29 Inch Tube	Discharge 60° 29 Inch Tube
Standard – No Extensions	125 Inches	14 ft. 9 in.	16 ft. 8 in.
3 ft. Fold Around Auger Extension	161 Inches	17 ft. 0 in.	19 ft. 3 in.
6 ft. Fold Around Auger Extension	197 Inches	19 ft. 3 in.	22 ft. 0 in.

Table 4 - Unloading Heights.

**UNLOADING AUGER HOOD**

When the unloading auger tube becomes overloaded, a spring loaded door opens on the end to prevent damage to the drive. (See Figure 34)



Figure 34 - Unloading Auger Hood.



Figure 35 - Auger Feeder Operation.

**AUGER FEED OPERATION**

**NOTE:** The grinder mixer may be equipped with a hydraulic auger feeder.

When processing material such as ear corn, the grate must be left in the up position.

To position the auger feeder, remove the clip pin from the fender bracket and lift the bottom of the auger feeder slightly so the brackets can clear the fender. Swing the auger feeder outward, away from the tank to ensure it will clear the fender when it is

**CAUTION: IF YOU MUST GRIND WITH THE GRATE UP, USE EXTREME CARE AND MAKE SURE TO STAY CLEAR OF THE AUGER.**

**DANGER: TO PREVENT PERSONAL INJURY:**

1. USE THE GRATE OVER THE AUGER WHENEVER POSSIBLE
2. KEEP HANDS AND FEET OUT OF THE HOPPER AREA AND DO NOT CLIMB ON OR OVER THE HOPPER AT ANY TIME.
3. KEEP CHILDREN AND BYSTANDERS AWAY FROM THE MACHINE WHILE THE MACHINE IS IN OPERATION

Make sure the auger feeder clutch handle will stop the auger feeder. Loosen the cable clamps to re-adjust.

The auger feeder swing brake prevents the auger from swinging. Tighten or loosen as desired. (See Figure 36)



Figure 36 - Auger Feeder Swing Brake

**NOTE:** If a more accurate reading is desired and the machine is equipped with an electronic scale, **DO NOT** rest the auger feeder on the ground. Place it in the desired position and set the swing brake.

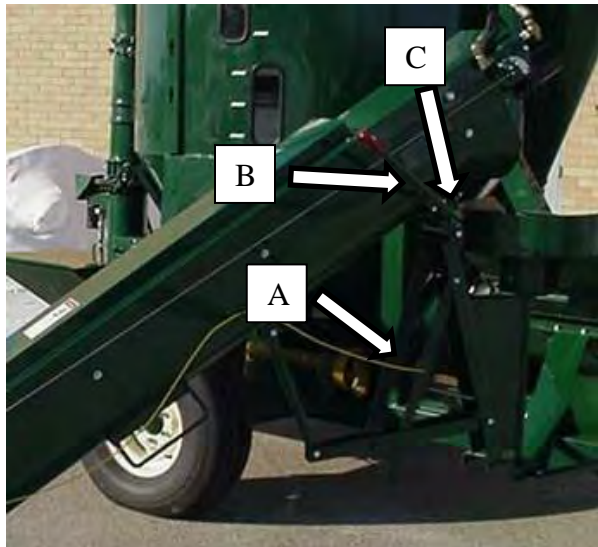

Figure 37 - Auger Feeder Positioner and Spring Adjustment (A - Spring; B - Positioner Handle; C - Positioner Lock).

The auger feeder is shipped with a transport locking plate (See Figure 38) that locks the positioner (See Figure 37) in one position. If the positioner is to be used, this plate is to be removed. But if the positioner is not needed, this plate can be kept in place to keep positioner from moving during transport of the grinder mixer.

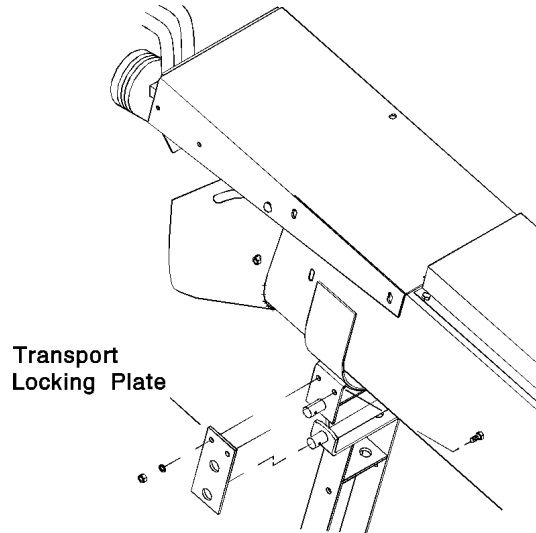

Figure 38 - Transport Locking Plate.



The auger feeder is equipped with a unique patented feature called a positioner. (See Figure 37.) This positioner allows the hopper to be re-positioned approximately 6 inches in or out without having to move the tractor. To operate the positioner; hold the long handle securely, release the short handle, re-position the auger feeder hopper under a spout or against a building, and then release the handles.

Shut-Off handles are provided at the auger feeder hopper and at the flow control valve at the top of the auger feeder housing. To shut off the auger feeder, pull the handle at the hopper area or move the flow control valve to off. (See Figure 39 and Figure 40)



**Figure 39 - Hydraulic auger feeder controls. (See arrows)**



**Figure 40 - Hydraulic Auger Feeder Control. (See Arrow)**

For the tractor hydraulic auger feeder (when equipped with a hydraulic lift and swing unloading auger), a selector valve will be located to the left rear side of the processor. The handle on this valve must be out to divert the oil to the auger feeder.

If the handle for the selector valve is in, oil flows to the swing function of the unloading auger. (See Figure 41)



**Figure 41 - Hydraulic Auger Feeder Selector Valve Lever Is In The Out Position - Auger Feeder.**

To start the auger feeder, the flow control handle is moved forward (clockwise) until the desired speed is reached.

If the hydraulic auger feeder is operated by tractor hydraulics, there must be a minimum of 8 GPM flow and 1500 psi pressure available.

## GRINDER MIXER ADJUSTMENTS



**CAUTION: DO NOT MAKE ANY ADJUSTMENTS WHILE THE MACHINE IS IN OPERATION.**

### DRIVE CHAIN ADJUSTMENTS

The mill to mixer auger/supplement hopper drive chain is tensioned by a sprocket idler and the discharge auger drive chain are tensioned with a wood block idler. (See Figure 42 and Figure 43) Adjust the chain tension to 1/2 inch total deflection by positioning the idler (wood or sprocket).



Figure 42 - Mill To Mixer Auger Drive Chain.



Figure 43 - Discharger Auger Drive Chain (Shields Removed for Clarity).

### MAIN DRIVE CHAIN

Adjust the tension of the main drive chain by loosening the idler roller and bolt, and then sliding the idler sprocket toward the chain. (See Figure 44) Re-tighten the idler roller bolt and make sure the chain deflection is 1/2 inch total at the longest span.

**NOTE:** The chain should be checked and oiled daily.



Figure 44 - Drive Chain Adjustment (Shields Removed For Clarity).

### MAIN DRIVE BELTS

Belts on new machines have been properly tensioned at the factory. To re-tension the belts on a machine which has been in operation.

- Loosen bolts "B" and "C". (See Figure 45)

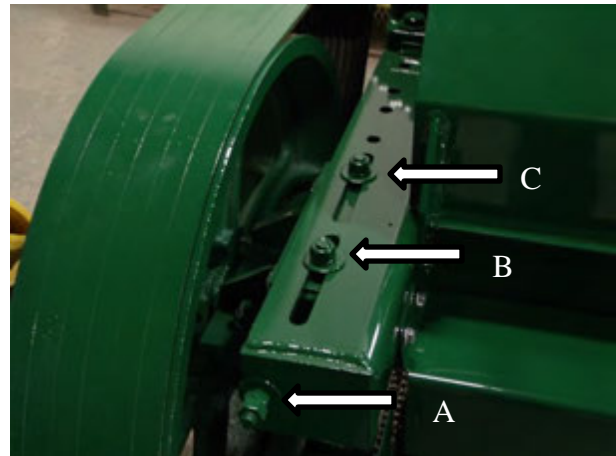

Figure 45 - Belt Tension Adjustment (Shields Removed For Clarity).

- Place a scale at the midway point of the double V-belts on the pulleys.
- Adjust bolt "A" (Figure 45, Detail A) until 15 pounds of pull on the scale raises the top of one double V-belt approximately 1/4 inch above the top of the remaining belts. (See Figure 48)
- All six pairs of belts should have the average of 1/4 inch deflection at 15 pounds.
- Loosen bolts "E" and "F" (See Figure 46)

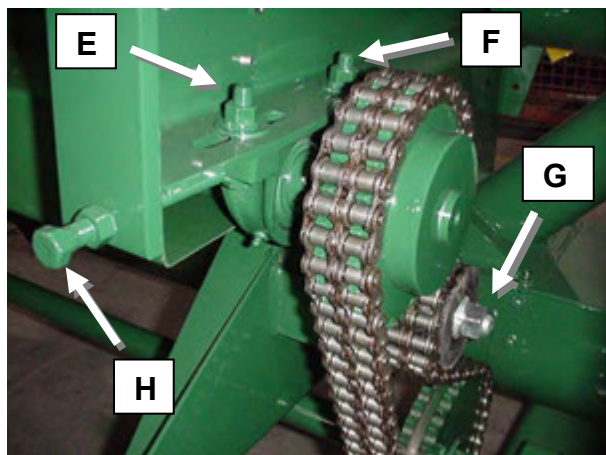

Figure 46 - Belt Tension Adjustment

- Loosen idler bolt "G"
- Adjust bolt "H" (See Figure 46) until Hammermill Jack Shaft "D" (See Figure 47) is parallel to Hammermill Housing. Measure both sides.

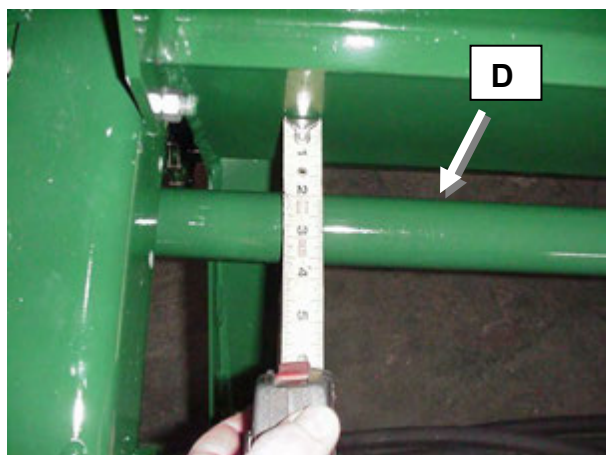

Figure 47 - Belt Tension Adjustment

- Tighten bolts "B", "C", "E", and "F". Lock adjusting bolts "A" in place with nut.
- Adjust tension in Main Drive Chain (See page 24).
- Reattach all shields removed or opened in previous steps.

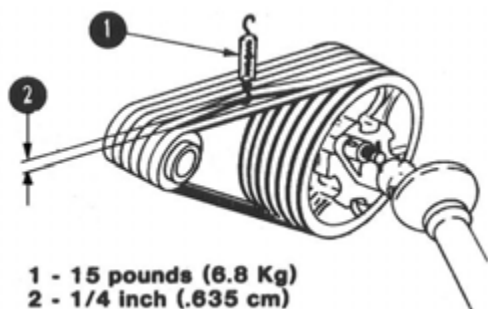

Figure 48 - Checking Belt Tension.

**IMPORTANT:** Proper alignment of the pulleys must be maintained when adjusting belt tension.

Belts should be checked periodically for proper tension and alignment, especially when the machine is new or when a new set of belts are installed. (See Figure 49) During operation, if the drive belts are very hot or are smoking due to being loose, do not shut off the machine, but stop grinding and allow the mill to continue to run for several minutes until the belts have cooled. After the belts have cooled, stop the machine to re-tension the belts.

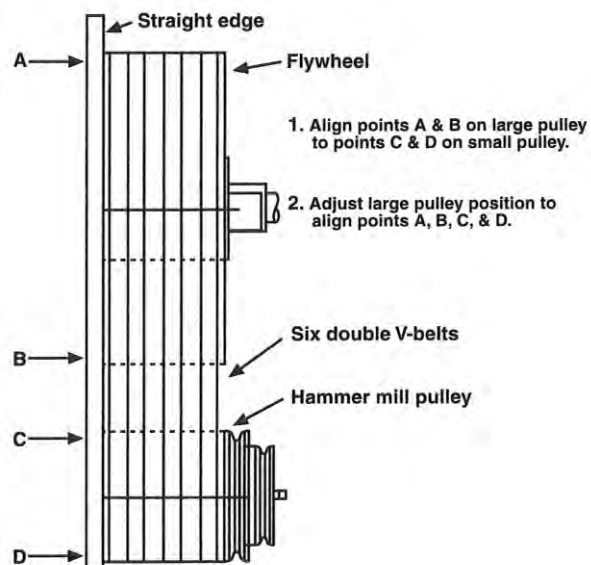

Figure 49 - Belt Pulley Alignment.

### HAMMERMILL DOOR

To increase the hammermill door pressure on the screen, adjust the length of the T-handle threaded end. Check the adjustment and tighten the locking nuts in place against the pivot block. (See Figure 50)



Figure 50 - Hammermill Door Pressure.

### **MANUAL UNLOADING AUGER SWING CRANK ADJUSTMENT FOR SPROCKET ENGAGEMENT**

Adjust by loosening the three bolts shown (Figure 51) and moving the assembly up to engage the teeth of the sprocket with the disk.



**Figure 51 - Manual Unloading Auger Swing Crank Adjustment**

### **MANUAL UNLOADING AUGER SWING BRAKE ADJUSTMENT**

Tighten or loosen nut and bolt, to maintain tension to hold unloading auger (See Figure 52).



**Figure 52 – Manual Brake Adjustment**

### **MANUAL LIFT ADJUSTMENT**

If the chain becomes loose, loosen bolts on the crank shaft and position chain to the proper tension (See Figure 53).



**Figure 53 - Crank Shaft Chain Adjustment Bolts**

### **LIFT ASSIST SPRING ADJUSTMENT**

The lift assist spring may lose tension after excessive usage. It is important to keep proper tension on the spring, this spring helps ease raising and lowering the discharge auger. Adjust the spring tension by removing bolt in hole and moving to the hole shown (Figure 54).

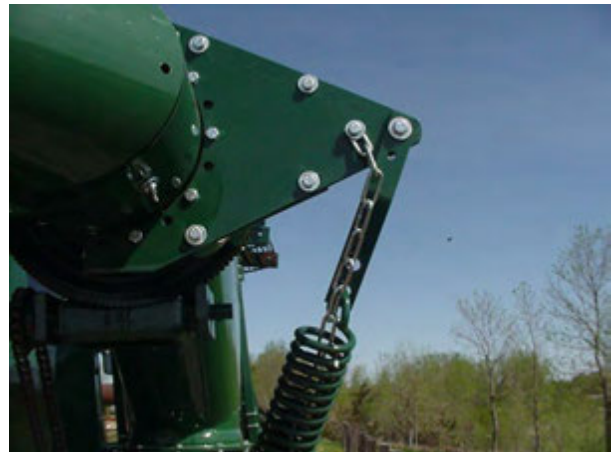

**Figure 54 - Lift Assist Spring Adjustment Bolts**

### **DISCHARGE AUGER LIFT CYLINDER ADJUSTMENT**

Turn the needle valve adjustment knob to control the speed at which the lift cylinder raises or lowers the discharge auger. This will be a slow speed to eliminate jump and bounce when activated. (See Figure 59)

**NOTE:** Needle valves control flow one direction only.

### **Hydraulic Discharge Chains Adjustment (6105H Models Only)**

Hydraulic Discharge models contain three 9.6 CID hydraulic motors (See Figure 55, Figure 56, and Figure 57).

The upper discharge motor is directly coupled to the auger shaft using four set screws (See Figure 55).

The middle discharge uses a #60 chain and sprockets. The tension is maintained using a positive stop style tensioner. Remove lower chain shield to access the chain. Loosen jam nut followed by tightening or loosening bolt for proper chain tension (See Figure 56).

Lower discharge motor uses a #40 chain, sprockets, and wood block idler. Position wood block idler against chain to adjust to proper tension. (Refer to Figure 43 for chain routing reference) Periodically wood block idler will need to be loosened and clocked differently to maintain the proper contact with chain (See Figure 57).

Middle and lower discharge motor chains should have no more than  $\frac{1}{2}$ " of deflection at longest span. Check chain tightness on regular basis to eliminate the risk of premature chain/sprocket wear and the possibility of "jumping teeth" during use.

**IMPORTANT:** Do NOT over tighten chains on middle and lower discharge motors, doing so will cause premature failure in motor seals and/or bearings.



Figure 55 - Upper Discharge Motor (Unload)



Figure 56 - Middle Discharge Motor (Vertical)



Figure 57 - Lower Discharge Motor (First Section)



Figure 58 - Discharge Auger Lift Cylinder Adjustment.

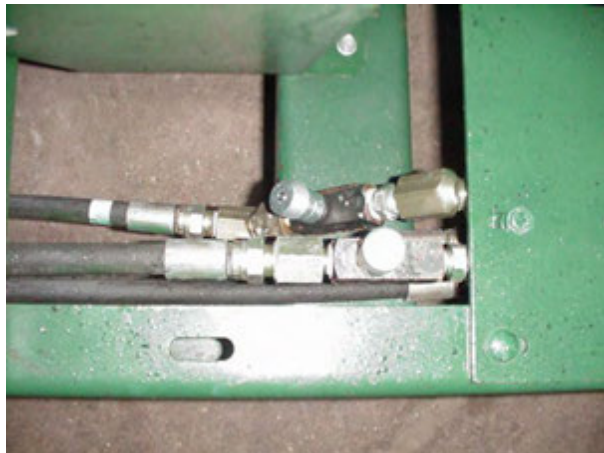

Figure 59 - Discharge Auger Lift Cylinder Needle Valves Adjustment (Located By Ladder)

### HYDRAULIC SWING ADJUSTMENT

If any problem is encountered with the hydraulic swing adjustment drive, adjust and/or check as follows: (See Figure 60)



Figure 60 - Hydraulic Swing Adjustment (Shields Removed For Clarity).

1. Loosen the four hydraulic motor bolts and remove the #60 chain.
2. Wrap the #60 chain completely around the 55 tooth sprocket. Inspect the chain, matching the sprocket teeth in the two areas where the sprocket is split. If the rollers on the chain do not seat into the root of the sprocket teeth, loosen the 10 bolts that hold the sprocket to the upper ring; holding the chain across the split areas, re-tighten the bolts so the chain properly seats into the sprocket teeth.
3. Re-tighten the hydraulic motor bolts then check the alignment of the sprocket. If the sprocket is not aligned properly, loosen the set screws on the 10 tooth sprocket and re-align.
4. Adjust the spring tension to make sure the auger will slip if it hits something solid. (See Figure 60.) If you fail to check the auger and the auger does not slip, damage to the discharge could occur.

### SWIVEL STOP

An unloading auger swivel stop prevents the unloading auger from contacting the mixing tank when moved 180 degrees from the storage position. (See Figure 61) Relocate the swivel stop so it makes contact with the bracket before the unloading auger contacts the tank.



Figure 61 - Swivel Stop.

### SWIVEL STOP ADJUSTMENT

Adjust the bracket so it makes contact before the unloading auger contacts the tank.

### OPEN AND CLOSED HYDRAULICS

As the standard, this machine is equipped for tractor "Open Center" hydraulic operation.

If the operation of the auger feeder is to be with a tractor that is equipped with a "Closed Center" hydraulic system, revision to the plumbing at the control valve bypass should be made. Refer to the tractor operator's manual or consult your local tractor dealer to make sure which system the tractor is equipped with. (See Figure 62)

To convert to "Closed Center" hydraulic system, revise as shown. (See Figure 62) If the system has two control valves for auger feeder and roll feed, change only the roll feed flow control valve. **When revised for "Closed Center" operation, do not use on a tractor with "Open Center".**

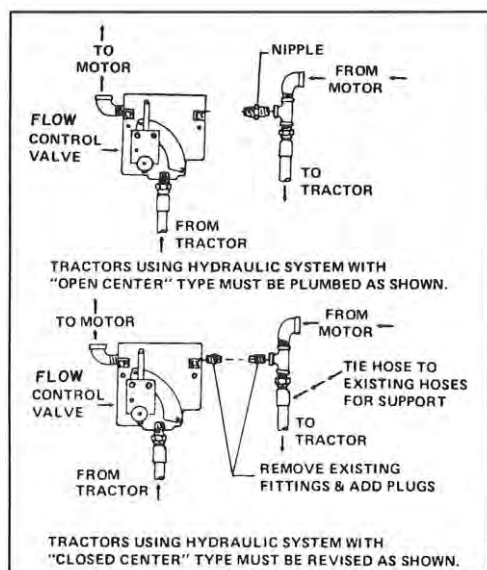

Figure 62 - Open And Closed Hydraulic Systems.

### CONVERTING TO CLOSED CENTER HYDRAULICS

To convert the hydraulic system to "Closed Center" perform the following: (See Figure 62)

1. At the control valve upper right corner, disconnect the hydraulic hose from the motor.
2. Disconnect the hydraulic hose to tractor from the tee and elbow then remove the nipple.
3. Install the plugs in the valve and tee where the nipple was removed.
4. Connect the hydraulic hoses to the tee and elbow.
5. Tie the hoses together for additional support.
6. If equipped with hydraulic roll feed, do not change the control valve for auger feed, change it for the roll feed.

### POSITIONING THE UNLOADING AUGER TO THE OPPOSITE SIDE OF THE MACHINE



**CAUTION: BEFORE REPOSITIONING THE UNLOADING AUGER TO OPPOSITE SIDE OF THE MACHINE, MAKE SURE THERE IS ENOUGH CLEARANCE FROM ALL OBSTRUCTIONS STRAIGHT UP AND TO THE REAR AND SIDES OF MIXER TANK THE SAME LENGTH AS THE UNLOADING AUGER.**

STEP 1 – (See Figure 63) Lift the unloading auger until the 5/8 inch hole in the lift lever is aligned with the 5/8 inch x 1 inch slot in the vertical cylinder mount arm. Lock the unloading auger into position with either a 5/8 inch bolt and nut or a 5/8 inch clevis pin.

STEP 2 – (See Figure 63) Detach the rod end of the cylinder from the ball joint on the lift lever. Retract the cylinder until it is aligned with the cylinder re-positioning hole and re-attach. Remove the locking bolt and/or pin from the 5/8 inch hole.

STEP 3 – (See Figure 64) Extend the cylinder until the 5/8 inch hole is aligned with the other 5/8 inch x 1 inch slot. Lock the cylinder into position with a 5/8 inch bolt and nut or a 5/8 inch clevis pin.

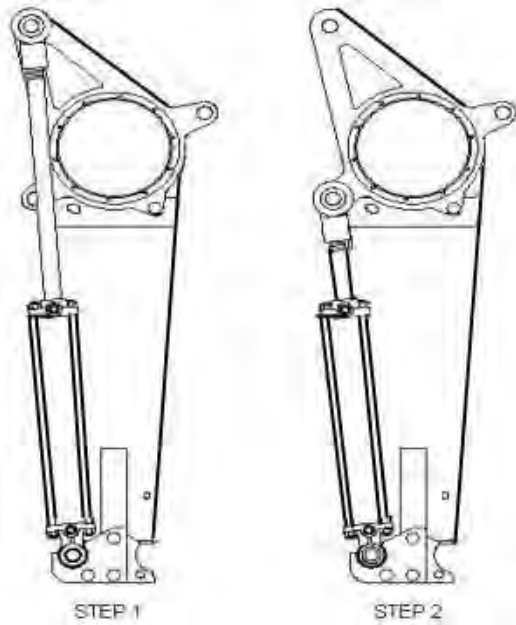

**Figure 63 - Repositioning Unloading Auger.**

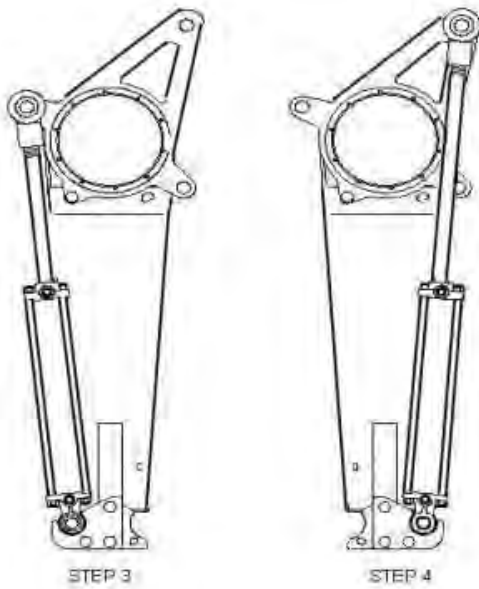

**Figure 64 - Repositioning Unloading Auger.**

STEP 4 – (See Figure 64) Disconnect the hydraulic hoses from the cylinder. Remove the cylinder and lower the cylinder mount from the lift lever and vertical cylinder mount arm.

Re-attach the cylinder on the other side as shown. (See Figure 64) Re-route the hydraulic hoses and connect to the cylinder. Move the saddle to the opposite side of the mixing tank. Lower the unloading auger and rotate the hood so it faces downward.

### **WHEEL BEARINGS**

Raise the frame and make sure it is blocked securely so the wheels may turn freely (make sure the opposite wheel is also blocked securely). To

tighten the wheel bearing, remove the hub cap. Remove the cotter pin from the slotted nut and tighten the slotted nut while rotating the wheel. Loosen or back-off the nut to the nearest slot, insert and spread the cotter pin.

There should be a slight drag on the bearing following the adjustment. Replace the hub cap. (See Figure 65)



**Figure 65 - Wheel Bearing Adjustment.**



## LUBRICATION



**CAUTION: BEFORE LUBRICATING THE MACHINE, MAKE SURE THE ENGINE IS SHUT OFF, PLACE THE KEY IN YOUR POCKET AND DISCONNECT THE IMPLEMENT INPUT DRIVELINE**

The grinder mixer is designed to require a minimum amount of lubrication. The points that are to be lubricated should be serviced regularly at the specified intervals listed in this manual.

Keep your supply of lubricating oil and grease in clean containers and covered to protect them from dust and dirt.

Keep the lubricating gun nozzle clean and free from dirt at all times. Wipe all of the dirt from the grease fittings before lubricating them.

### PTO DRIVELINE

Grease the bearing crosses, telescoping, and plastic shield rotation every 20 hours. The zerk is located on the sliding shaft. (See Figure 66 and Figure 67)



Figure 66 - PTO Driveline (Shield Removed For Clarity).



Figure 67 - Plastic Shaft Bearings (See Arrow).

### HAMMERMILL SHAFT BEARINGS

Grease the front and rear pillow block bearings on the hammermill cylinder shaft every week or every 10 hours of operation. Do not overgrease. (See Figure 68 and Figure 69) Use SAE multi-purpose type grease for this lubrication.

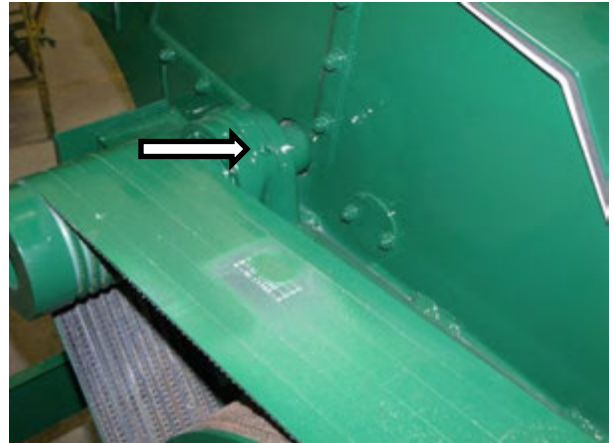

Figure 68 - Cylinder Shaft Bearing (See Arrow) (Shields Removed For Clarity).

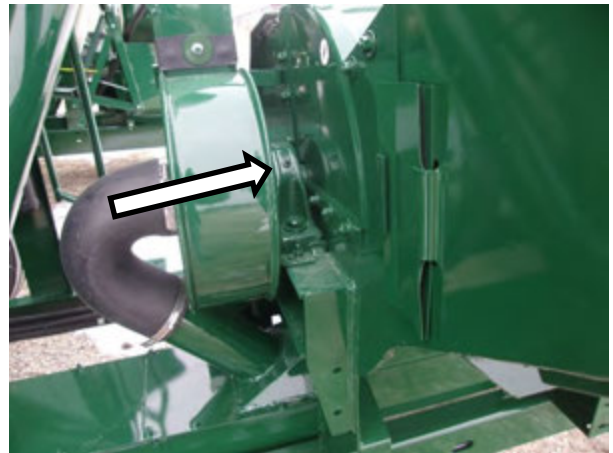
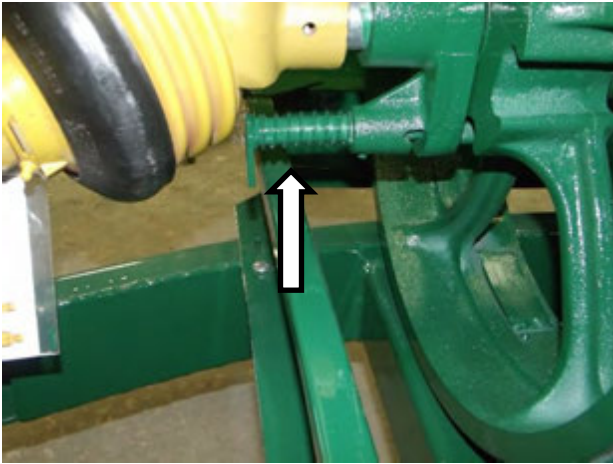

Figure 69 - Cylinder Shaft Bearing (See Arrow) (Shields Removed For Clarity).

### HAMMERMILL ENGAGING PIN

Periodically oil the sliding pin that engages the large hammermill drive pulley. Use a light engine oil for lubrication. (See Figure 70)

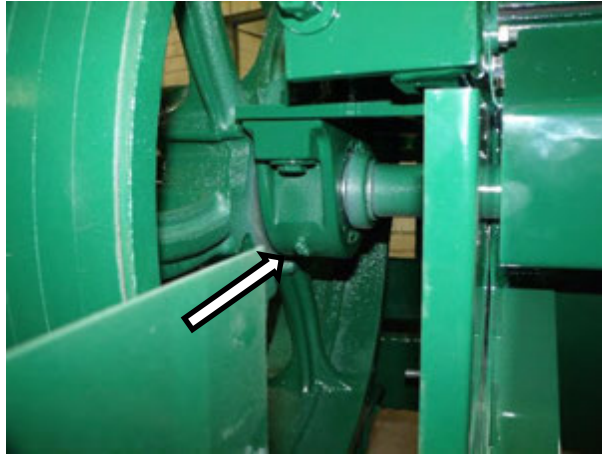

**Figure 70 - Hammermill engaging pin (shields removed for clarity).**

**DRIVE SHAFT BEARINGS**

Every month or every 25 hours of operation.

Grease the pillow block bearings on the front and rear bearings on the hammermill jack shaft. (See Figure 71 and Figure 72) Grease pillow block bearings on the lower line shaft. (See Figure 73 and Figure 74) Use SAE multi-purpose type grease for these lubrications.



**Figure 71 - Jack Shaft Front Bearing, Front (Shields Removed For Clarity).**

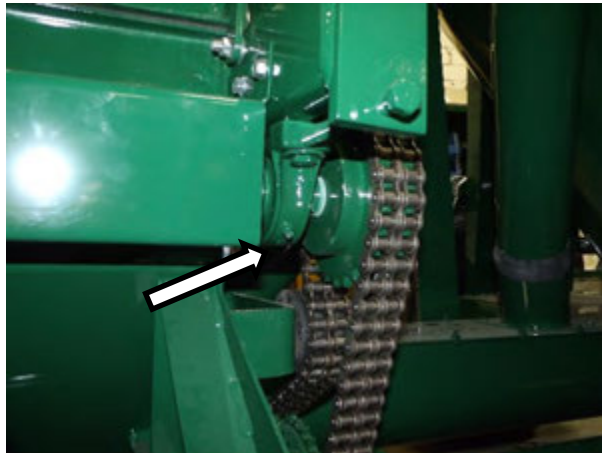

**Figure 72 - Jack Shaft Front Bearing, Rear (Shields Removed For Clarity).**

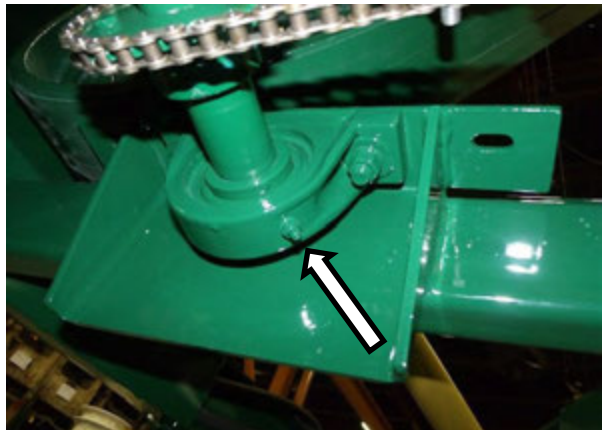

**Figure 73 - Mixer Drive Shaft Bearing, Front.**

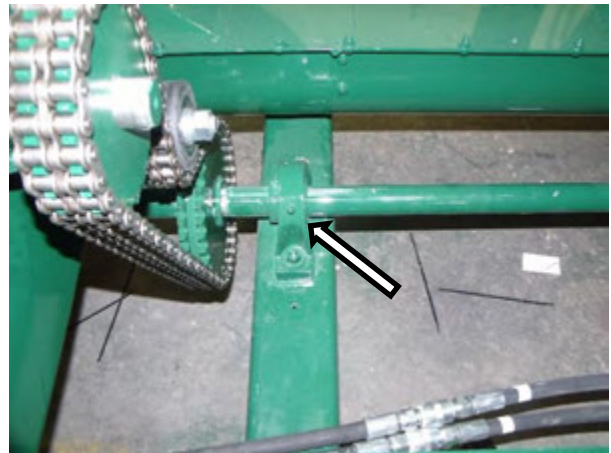

**Figure 74 - Mixer Drive Shaft Bearing, Rear.**

**CHAINS**

Chains should be lubricated at frequent intervals. Apply a light engine oil to the chain. Oil the chain on the inside located in the upper side of lower the strand. (See Figure 75)

The chains should also be cleaned regularly. Remove the chains and dip or soak them in kerosene. Once the chains have been cleaned, dry and oil them thoroughly.

**Oil Roller Chain on Upper Side of Lower Strand**

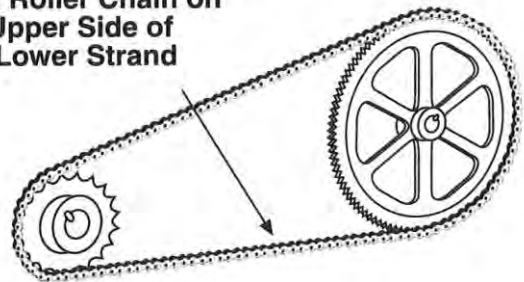

**Figure 75 - Oiling Roller Chains.**

The split end of the chain clip must face the direction opposite of the chain travel. Make sure the clip is properly seated in the groove on the ends of the pin. (See Figure 76)

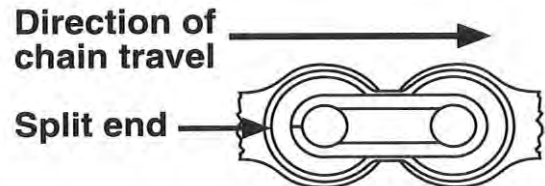

**Figure 76 - Chain Spring Clip.**

## GEARBOX

Make sure to check the oil level on the gearbox at the base of the mixing tank every 6 months by removing the check plug at the front of the gearbox. Add SAE 90 weight gear oil if necessary and until oil runs out of the check hole. (See Figure 77)

**IMPORTANT:** Do not overfill.

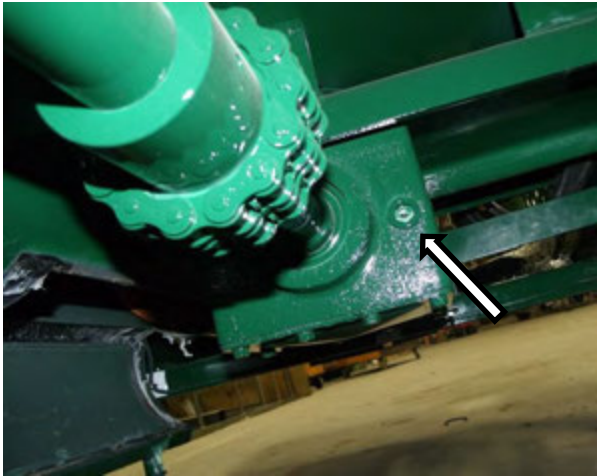

Figure 77 - Gearbox Lubrication.

## LOWER VERTICAL MIXING AUGER

Refill the grease seal at the bottom of the vertical mixing auger every six months with SAE multi-purpose type grease. Access to this fitting can be gained through the clean-out door in the mixing tank cone, below the large bottom flight of the mixing auger. (See Figure 78)

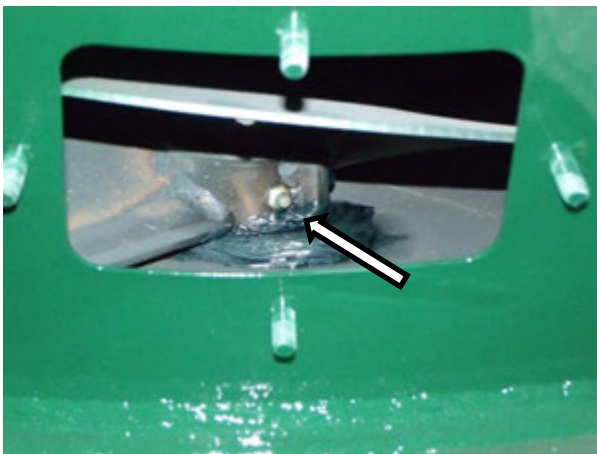

Figure 78 - Clean-Out Door in Mixing Tank Cone And Grease Zerk For Seal At Bottom Of Vertical Mixing Auger.

## UPPER VERTICAL MIXING AUGER

Grease the upper vertical mixing auger bearing weekly or every 10 hours of operation with SAE multi-purpose type grease. Access to this bearing can be gained through the top of the mixing tank. (See Figure 79)



Figure 79 – Upper Vertical Mixing Auger Bearing.

## UNLOADING AUGER CLUTCH

Apply SAE multi-purpose grease to the shaft and groove in the under sliding (driven) unloading auger clutch half. This should be done periodically to ensure proper lubrication. (See Figure 80)



Figure 80 - Unloading Clutch Operation.

## SWIVEL CLAMP

Grease the lower swivel clamp every week to ensure the swivel clamp is properly lubricated. (See Figure 81)



Figure 81 - Swivel Clamp Area, Discharge Auger (Shield Removed For Clarity).

**ELBOW**

Periodically grease the gear sets at each unloading auger transfer point using SAE multi-purpose grease. The lower gears (Figure 84) have a zerk and are enclosed to keep more grease in contact with the gears. (See Figure 82, Figure 83 and Figure 84)



Figure 82 - Discharge Auger Bevel Gears, Inner Elbow (Shields Removed For Clarity).



Figure 83 - Discharge Auger Bevel Gears, Outer Elbow (Shields Removed For Clarity).

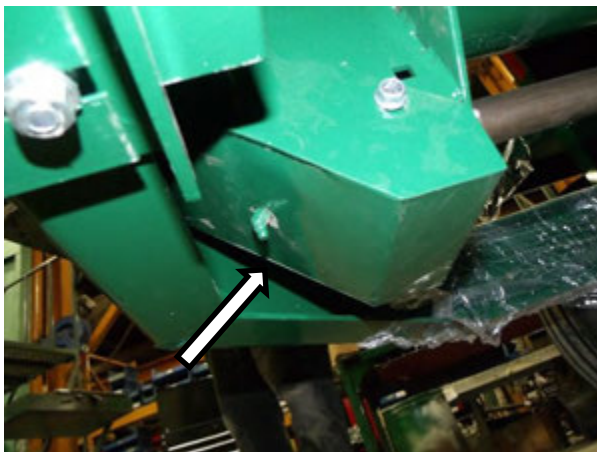

Figure 84 - Vertical Auger Bevel Gears Shield.

**HYDRAULIC LIFT**

Periodically grease the two locations on the hydraulic lift lever arm using SAE multi-purpose grease. (See Figure 85.)

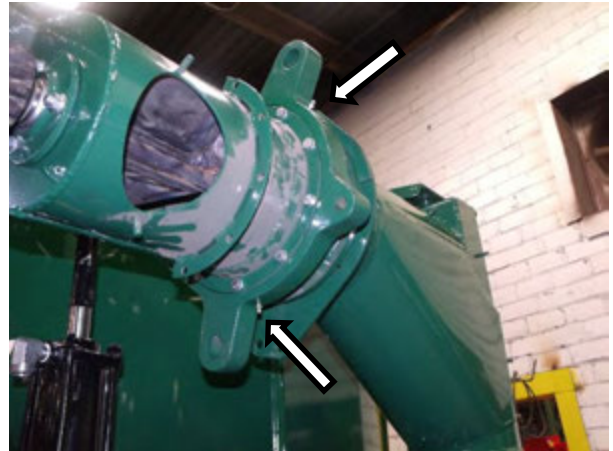

Figure 85 - Hydraulic Lift Grease Locations.

**RING AND WORM GEAR (MECHANICAL)**

Grease at two locations on large ring gear on unloading auger and apply grease at ring gear and worm gear periodically. Use SAE multi-purpose type grease. Also every six months repack 3/4 inch dia. bearings on worm shaft (See Figure 86). Grease lubrication fittings and outside diameter of ring gear with multi-purpose grease every ten hours of operation (See Figure 87)



Figure 86 - Ring and Worm Gear Bearings



Figure 87 - Ring and Worm Gear Fittings

### **WHEELS**

Remove, clean, and repack the wheel bearings once a year or every 100 hours of operation using SAE multi-purpose type grease. (See Figure 88)



Figure 88 - Wheel Bearing Lubrication.

# SERVICE

## TORQUE SPECIFICATIONS



**CAUTION: DISENGAGE ALL DRIVES AND MAKE SURE THE TRACTOR ENGINE IS SHUT OFF. PLACE THE KEY IN YOUR POCKET AND DISCONNECT THE PTO DRIVELINE PRIOR TO SERVICEING THE GRINDER MIXER.**

When performing service on the grinder mixer and its components, take time to use and comply with the torque specification guide. (Refer to Table 5.)

Size	Clamp Load	Plain GR 5	Plated GR 5
1/4 – 20 (.250)	2,025	8 ft. lbs.	76 in. lbs.
5/16 – 18 (.3125)	3,338	17 ft. lbs.	13 ft. lbs.
3/8 – 16 (.375)	4,950	31 ft. lbs.	23 ft. lbs.
7/16 – 14 (.4375)	6,788	50 ft. lbs.	37 ft. lbs.
1/2 – 13 (.500)	9,075	76 ft. lbs.	57 ft. lbs.
9/16 – 12 (.5625)	11,625	109 ft. lbs.	82 ft. lbs.
5/8 – 11 (.625)	14,400	150 ft. lbs.	112 ft. lbs.
3/4 - 10 (.750)	21,300	266 ft. lbs.	200 ft. lbs.
7/8 – 9 (.875)	29,475	430 ft. lbs.	322 ft. lbs.
1 – 8 (1.00)	38,625	644 ft. lbs.	483 ft. lbs.
1-1/8 – 7 (1.125)	42,375	794 ft. lbs.	596 ft. lbs.

**Table 5 - Torque Specification Guide For Grade 5 Bolts.**

## SHEAR BOLTS



**WARNING: SHEAR BOLTS MAKE A LOUD NOISE WHEN SHEARED. IMMEDIATELY SHUT THE TRACTOR IGNITION OFF AND DETERMINE THE CAUSE OF SHEARING.**

Shear bolts will make a loud noise when they shear. This is your warning to turn off the tractor ignition immediately and determine the cause of the shear.

When replacing sheared bolts, always tighten them securely using lock nuts. The shear bolts must be the correct harness to ensure safety. (See Figure 89)

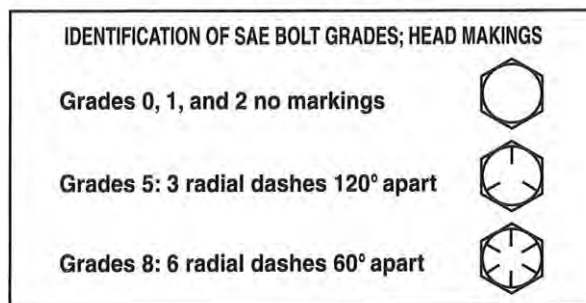

**Figure 89 - SAE Bolt Identification.**

## SPROCKET AND CHAIN ALIGNMENT

Make sure the sprockets are in line with each other. (See Figure 90 and Figure 91) If the sprockets are not aligned a sideways pull will develop and will concentrate the load on sides of the sprocket teeth and on the side of the chain. (See Figure 92) This faulty alignment will result on excessive wear on both the chain and sprockets.



**Figure 90 – Jack Shaft to Mixing Auger Sprockets (Shields Removed For Clarity).**



**Figure 91 – Mill To Mixer Sprocket (Shields Removed For Clarity).**

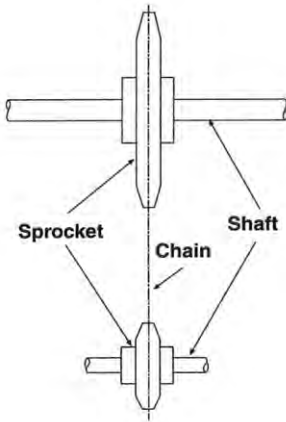

Figure 92 - Sprocket Alignment.

**REPLACEMENT OF WORN OR DAMAGED HAMMERS**

Hammers must be replaced in pairs to maintain proper balance. This is accomplished by replacing the hammers opposite of each other (180 degrees apart) using a matched pair.

**REVERSING THE HAMMERS**



**CAUTION: MAKE SURE THE HAMMERMILL HAS STOPPED ROTATING BEFORE THE HAMMERMILL DOOR IS OPENED. SHUT THE TRACTOR IGNITION OFF AND PLACE THE KEY IN YOUR POCKET. SAFELY DISENGAGE ALL DRIVES.**

There are four rows of hammers in the rotor assembly with a total of 72 hammers on a 20 inch hammermill. (See Figure 93) The hammers are reversible, but make sure to always replace the hammers and spacers in the exact sequence in which they were removed. This will preserve the balance of these specially matched units. All four corners can be used on each hammer.

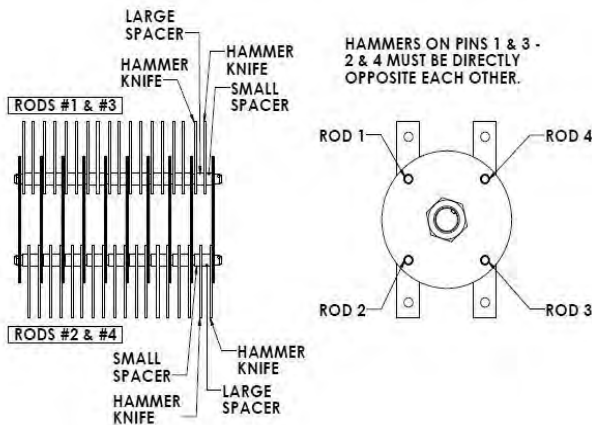

Figure 93 - Proper Hammer Spacing For 72 Hammers (20 Inch Hammermill).

To remove the hammers, remove the bolts from the side of the mill and round plate. (See Figure 94 and Figure 95.) Remove the pins from each end of the rod and pull the rods outward making sure the hammers are put back in the same place from which they were removed.

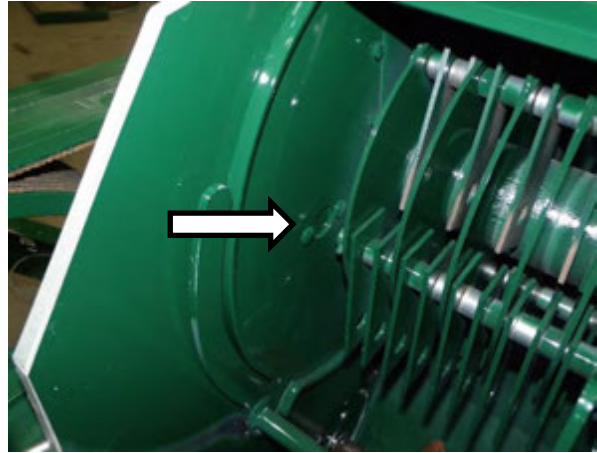

Figure 94 - Hammer Removal Inside Hammermill, Hole To Remove Hammermill Rods (Shields Removed For Clarity).

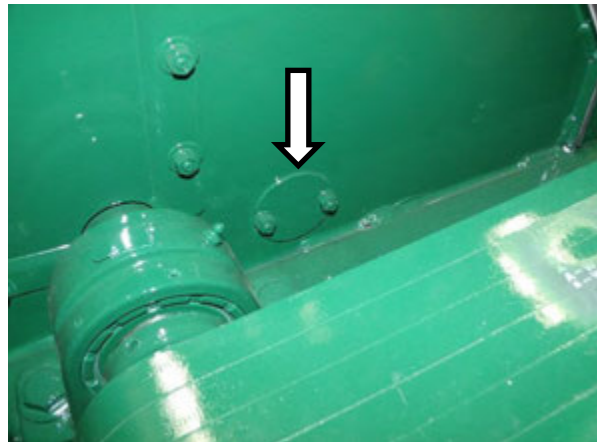

Figure 95 - Hammermill Removal Hole, Plate To Be Removed (Shields Removed For Clarity).

**MAIN DRIVE BELT REPLACEMENT**

To remove the drive belts, loosen the bolts. (See Figure 96, Detail B and C.) To relieve the belt tension, loosen the bolts. (See Figure 82, Detail A.)

After the belts are no longer tensioned, remove the belts and replace them with the new set and continue as described in GRINDER MIXER ADJUSTMENTS - Main Drive Belts. Make sure to align the pulley and the sheave.



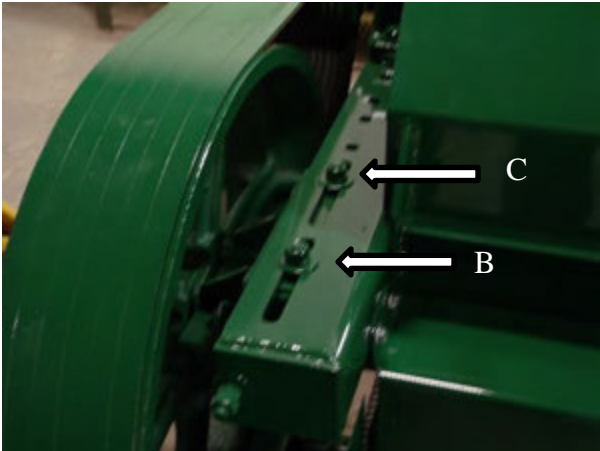

Figure 96 - Belt Removal (Shields Removed For Clarity).

## TROUBLESHOOTING GUIDE

The majority of difficulties are caused by improper adjustments. When you encounter trouble, perform a systematic check of all possible adjustments using the chart that follows. If difficulties cannot be corrected by making the adjustments that follow, consult your local Art's Way authorized dealer for further assistance.

TROUBLE	POSSIBLE CAUSE	POSSIBLE REMEDY
PTO driveline is hard to telescope and hard to connect	Shafts are twisted due to overloading of the mill	Replace PTO driveline if necessary, load uniformly, and adjust belts to prevent slipping (1000 rpm recommended over 100 hp)
	Lack of grease on the sliding halves	Lubricate as necessary
Mill vibrates excessively while in operation	PTO driveline is not properly aligned	Front of grinder main shield must be parallel to tractor axle
	PTO driveline is bent	Replace the PTO driveline
	Missing and/or broken hammers	Replace the hammers (in pairs)
	Tractor drawbar is not adjusted properly	Adjust the tractor drawbar (Refer to Figure 13.)
Excessive noise when turning the mixer while it is in operation	Turning the mixer too sharply	Avoid sharp turns
Low volume from hammermill	Hammermill is not operating at optimum speed	Before grinding, set tractor throttle to rated PTO speed (540 or 1000 rpm)
	Hammermill screens and/or hammers are worn	Reverse and/or replace the screens and hammers if necessary
	Hammermill is not level	Find level surface if at all possible
	Mill drive belts are slipping	Adjust the drive belts
Tractor engine RPM falls below the rated PTO speed while grinding	Adding too much feed to the mixer	Reduce flow of material to the mill
	Screen size is too small	Increase the screen size
	Feed gate is too high	Lower the feed gate
	Drive belts are too loose	Adjust the drive belts
Drive belt squeals when the mill is engaged	Drive belts are too loose	Tighten the drive belts
Drive belts show excessive wear	Belts are out of alignment	Align the pulleys
	Belts are slipping	Adjust the belts
Material bridges in the tank	High moisture content ear corn or too much hay is being ground	Grind high moisture ear corn last or run straight through tank
		Use a smaller screen or add more grain with hay
Feed roll will not draw hay slice into the mill	Feed roll is too low	Raise the feed roll
		Adjust the hay retard bolts

TROUBLE	POSSIBLE CAUSE	POSSIBLE REMEDY
Mill will run but the unloading auger and the mixing auger do not run	Pin(s) sheared in the drive	Repair the cause of the sheared pin(s) and replace
Unloading auger run, but the feed is not unloading	Mixer tank door is closed	Open the mixer tank door
Unloading auger will not engage	Unloading auger clutch linkage needs adjusted	Adjust the clutch linkage
	Clutch sticking	Engage the clutch
Auger feeder stops when the mill is engaged	Hydraulic flow control valve is disengaged	Engage the flow control valve
	Selector valve is not positioned correctly	Change the position of the selector valve (out for auger feeder)
Discharge auger jerks when it is raised or lowered	Excessive hydraulic flow rate to lift cylinder	Adjust the flow rate with the needle valves (See Note)
	Lift lever is binding on holder	Grease the zerks on the lift lever
Discharge auger raises and lowers too slowly	Incorrect hydraulic flow rate to the lift cylinder	Adjust the flow rate with the needle valves (See Note)

**NOTE:** Both valves should be set to the same flow rate. Unequal settings will cause excessive motor backpressure and shaft seal failure.

## ATTACHMENTS

### ELECTRIC ACTUATOR OPTION

#### *Preparing the Tractor*

Install the control box in the cab of the tractor using the mounting bracket provided. Connect the power cord to a suitable 12 VDC power supply. The tractor must be able to provide 12 to 15 VDC and 20 ampere to operate the electrical activated control valve. For the direct connection to the battery, see Figure 97.

**NOTE:** The electrical system of the tractor must be in good working order. If a voltage of less than 12 VDC is provided to the actuator, the system will not operate properly. There is a 20 amp fuse mounted on the tractor control box for electrical overload protection.

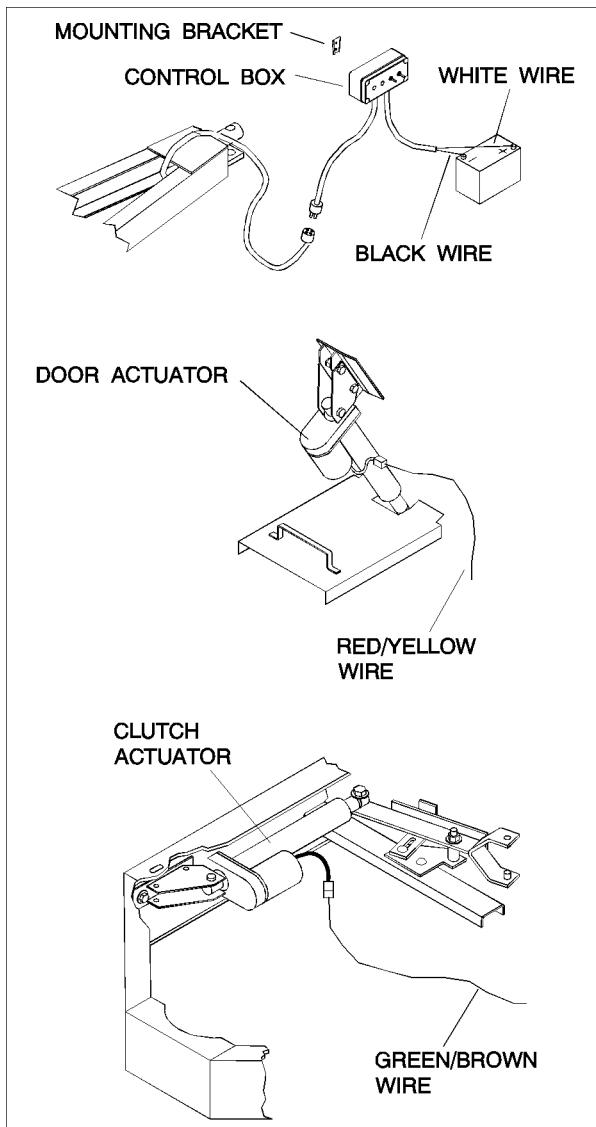

Figure 97 - Control Box Installation.

#### *Preparing the Grinder Mixer*

Electrical Components:

Connect the tractor control box to the machine with the plug that has been provided.

Activate the electric linear actuator to engage the clutch. It will ratchet when the actuator is fully retracted. From this point, the clutch should be fully engaged. The clutch arm should be loosely riding in the groove of the clutch.

Adjustments can be made by loosening the rear mounting bracket bolts and sliding the actuator assembly to the desired setting.

To engage the discharge auger, activate the electrical linear actuator until a "ratchet" sound is heard. This will indicate that the clutch is fully engaged. Excessive wear of the clutch teeth will result if the clutch is not fully engaged. (See Figure 98.)



Figure 98 - Discharge Clutch Actuator.

To operate the discharge door, activate the electrical linear actuator. The actuator will "ratchet" when the door is fully opened or closed. (See Figure 99.)



Figure 99 - Discharge Door Actuator.

### **ELECTRONIC SCALE ATTACHMENT**

A solid state electronic scale attachment, digital type, is available for your grinder mixer. The scale attachment consists of waybar sensors mounted on the grinder mixers axle spindles and hitch. They are electronically connected to the indicator bars. The indicator alarm system is available with the electronic scale attachment. Scale accuracies of 1percent or less are obtained. Complete installation and operating instructions are included with the attachment.

### **ADJUSTABLE SCALE ARM ATTACHMENT**

The optional scale arm allows the electronic scale to be positioned along a 180° arc off the side of the grinder. (See Figure 100.) Tension on the pivot point spring can be increased or decreased by tightening or loosening the nut. Periodic grease needs to be applied to the zerk on the pivot point.

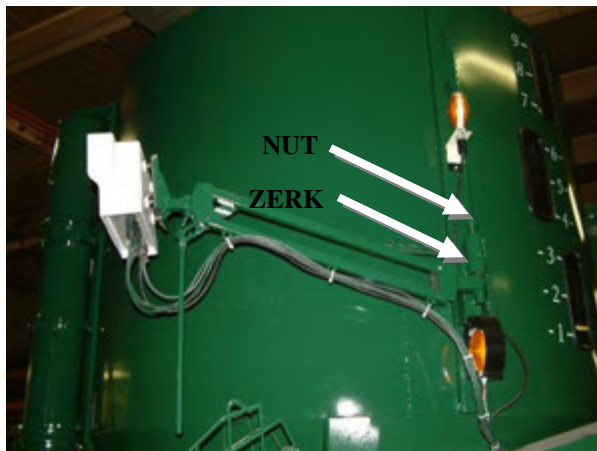

Figure 100 – Adjustable Scale Arm Attachment

### **DISCHARGE UNLOADING AUGER EXTENSIONS**

3 foot and 6 foot folding and 3 foot and 6 foot bolt-on discharge auger extensions are available. (See

Figure 101) For unloading height obtainable with various extensions added to the unloading auger system, refer to Table 4. For unloading auger instructions, refer to OPERATION OF GRINDER MIXER section.



Figure 101 - Folding Auger Extensions.

### **SCREENS**

Screens for hammermills are available in 12 sizes ranging from 1/8 inch to 2 inch. Refer to OPERATION OF GRINDER MIXER - Hammermill Screens.

### **HYDRAULIC ROLL FEED**

The hydraulic roll feed provides easier feeding of exceptionally coarse material such as ear corn, corn cobs or hay. Additional protection is provided for the operator and more even particle size will be obtained. (See Figure 102)

To maintain even feeding, the roll feed may be set at a desired height by using the roll feed crank. Roll feed settings will vary with the material being fed. Brief experience will indicate the best settings. Set the roll feed just high enough so that the material is being pulled smoothly.

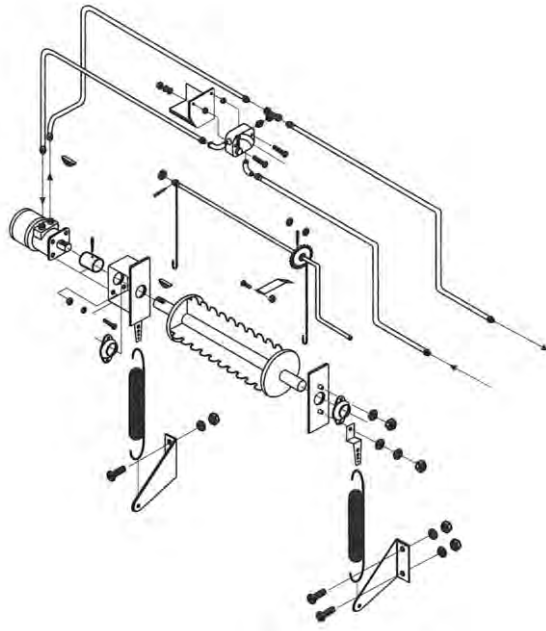

**Figure 102 - Roll Feed With Auger Feeder Shown.**



**CAUTION: NEVER FORCE MATERIAL INTO THE ROLL FEED WITH A STICK OR WITH HANDS. BE ESPECIALLY CAREFUL WHEN FEEDING SLICES OF HAY, ALWAYS ALLOWING THE ROLL FEED TO PULL THE HAY INTO THE MILL.**

The hydraulic roll feed is connected in series with the hydraulic auger feeder. A separate flow control valve allows separate speed control for the roll feed. If equipped with the hydraulic roll feed only, the flow control is on top of the hammermill. The crank for lowering the roll feed is toward the front of the hammermill housing. (See Figure 103).



**Figure 103 - Roll Feed and Auger Feeder Flow Control Valves.**

### **ROLL FEED ADJUSTMENT**

Five holes are provided at the upper end of the roll feed spring. The roll feed tension can be changed

as desired. Generally, the top hole is used for hay. (See Figure 104)



**Figure 104 – Hydraulic Roll Feed Motor.**

If the roll feed does not crank up straight, check the cables at each side of the roll feed to see if they are both uniform on the roll feed crank shaft. (See Figure 105)



Figure 105 – Roll Feed Crank.

Cable lengths can be adjusted by loosening the nut with the special cable washer and retightened after the cables have been equalized.

## SPECIFICATIONS

### TANK AND FRAME

- Capacity of mixing tank: ..... 105 bu. 129 cu. ft.
- Height (variable with tire size): ..... 106 inches.
- Width without auger feeder: ..... 95 inches.
- Overall length: ..... 170 inches.
- Weight: ..... 3,540 lbs.

### DISCHARGE AUGER

- Auger diameter: ..... 7 inches.
- Auger tube diameter: ..... 8 inches.
- Horizontal operating arc: ..... 324°
- Vertical operating arc: ..... Infinite

### AUGER FEEDER

- Auger length: ..... 100 inches.
- Auger diameter: ..... 10 inches.
- Hopper width open: ..... 43 inches.
- Height of hopper from ground in down position: ..... 16-1/2 inches.
- Height of hopper from ground in up position: ..... 51 inches.

### MIXING AUGER

- Auger width ..... 12 inches.
- Mixing base ..... 24 inches.

### SUPPLEMENT HOPPER

- Auger diameter ..... 7 inches.
- Hopper size ..... 21 inches X 24 inches
- Height from ground ..... 34 inches

### HAMMERMILLS

- Tank and frame ..... 20 inches
- Width of mill ..... Full 20 inches
- Screen area ..... 600 sq. in.
- Operating speed ..... 540 RPM
- Operating speed of mill ..... 2,800 to 3,000 RPM
- Screen sizes available ..... 1/8, 5/32, 3/16, 1/4, 3/8, 1/2, 5/8,  
3/4, 1, 1-1/4, 1-1/2, and 2 inch
- Type drive ..... Six double banded 3V belts for 540 RPM

**POWER REQUIRED** ..... 40 to 100 hp



# 6105 CATTLEMAYX

## SAFETY DECALS

### DECAL LOCATIONS & IDENTIFICATION

The different types of safety decals for your CattleMaxx are illustrated on the following pages (See Figure 106, Figure 107, and Figure 108). Please familiarize yourself with the appearance of each decal, the warning it describes, and the area where it is located on the CattleMaxx.

Safety awareness is the responsibility of each operator of the CattleMaxx. Keep safety decals and signs clean and legible and be sure replacement parts display the current safety decals and signs as well.

**Remember: Always replace missing, damaged or illegible safety decals. New decals and signs are available from an authorized dealer.**

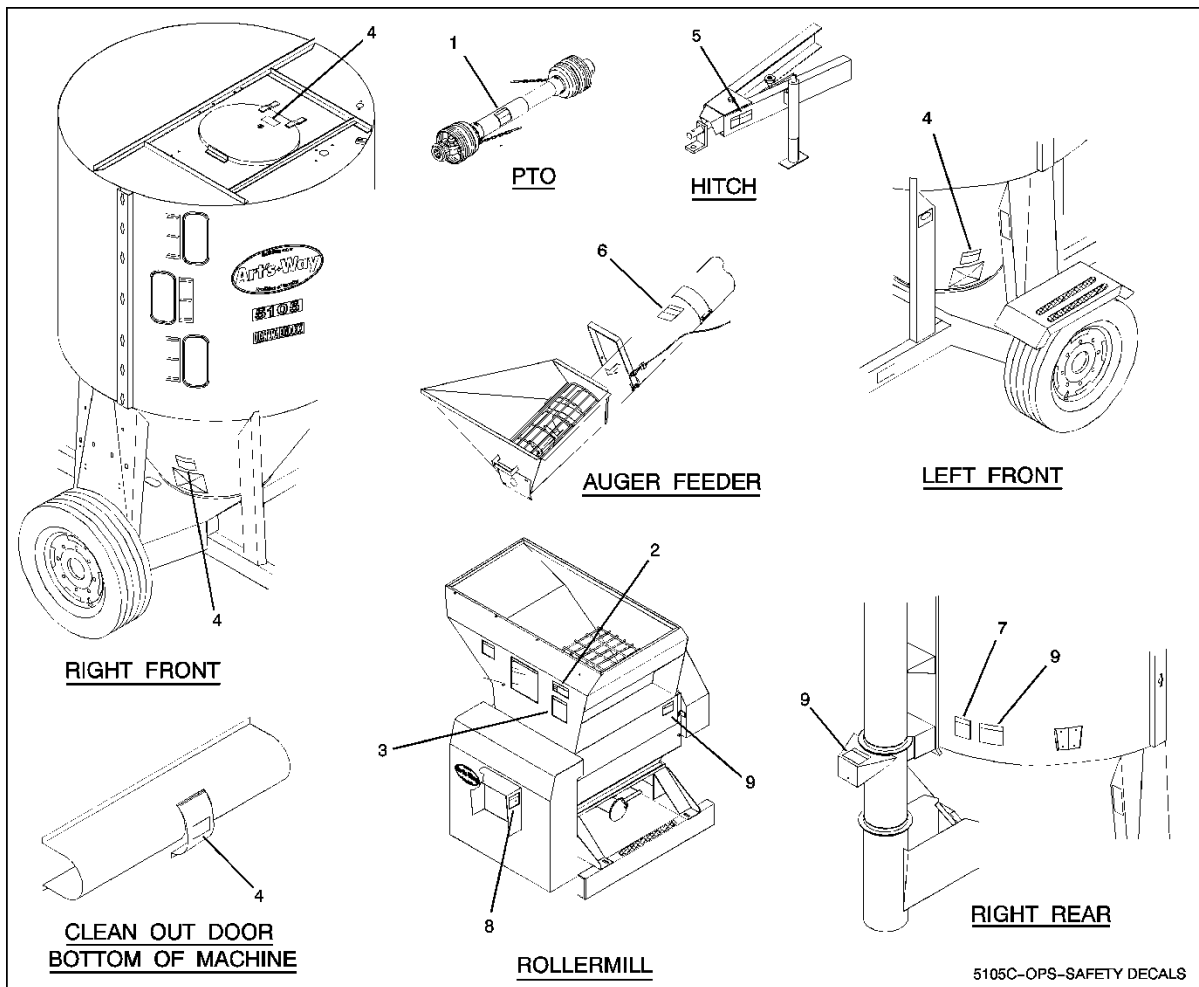

Figure 106 - CattleMaxx Decals

FIG ITEM	PART NUMBER	NOMENCLATURE	UNITS PER ASSY
1	268860	DECAL, DANGER ROTATING DRIVE LINE	1
2	P99897	DECAL, WARNING ROLLS, BELT	1
3	368040	DECAL, CAUTION SAFETY INSTRUCTIONS	1
4	377280	DECAL, CAUTION DO NOT OPEN	4
5	383970	DECAL, CAUTION HITCH INSTRUCTIONS	1
6	383990	DECAL, DANGER AUGER FEEDER	1

7	384000	DECAL, DANGER ELECTROCUTION HAZARD	1
8	384030	DECAL, DANGER 565 RPM PTO	1
9	467450	DECAL, WARNING MOVING PART HAZARD	3

**NOTE:** Keep all decals clean and free of dirt for maximum visibility. Replace all individual decals that are no longer legible. Read and obey all safety decals and be familiar with their meaning.



1. DANGER - Shield Missing (467430)



2. DANGER - 540 RPM PTO (384030)



3. DANGER - Rotating Driveline (268860)



4. DANGER - Auger Feeder Hazard (383990)



5. DANGER - Electrocutation Hazard (384000)

Figure 107 - Safety Decals.

**NOTE:** Keep all decals clean and free of dirt for maximum visibility. Replace all individual decals that are no longer legible. Read and obey all safety decals and be familiar with their meaning.



6. WARNING – Moving Part Hazard (467450)



7. CAUTION – Safety Instructions (368040)



8. WARNING –High Pressure Fluid Hazard (346310)



9. CAUTION – Do Not Open (377280)

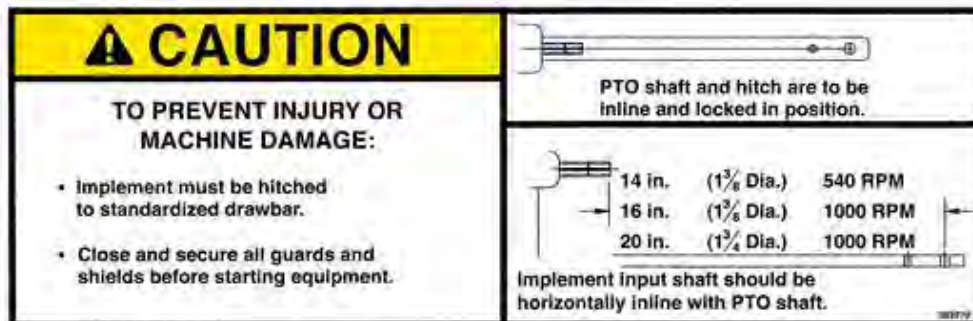

10. CAUTION – Hitch Instructions (383970)

Figure 108 - Safety Decals.

**NOTE:** Keep all decals clean and free of dirt for maximum visibility. Replace all individual decals that are no longer legible. Read and obey all safety decals and be familiar with their meaning.

## INTRODUCTION

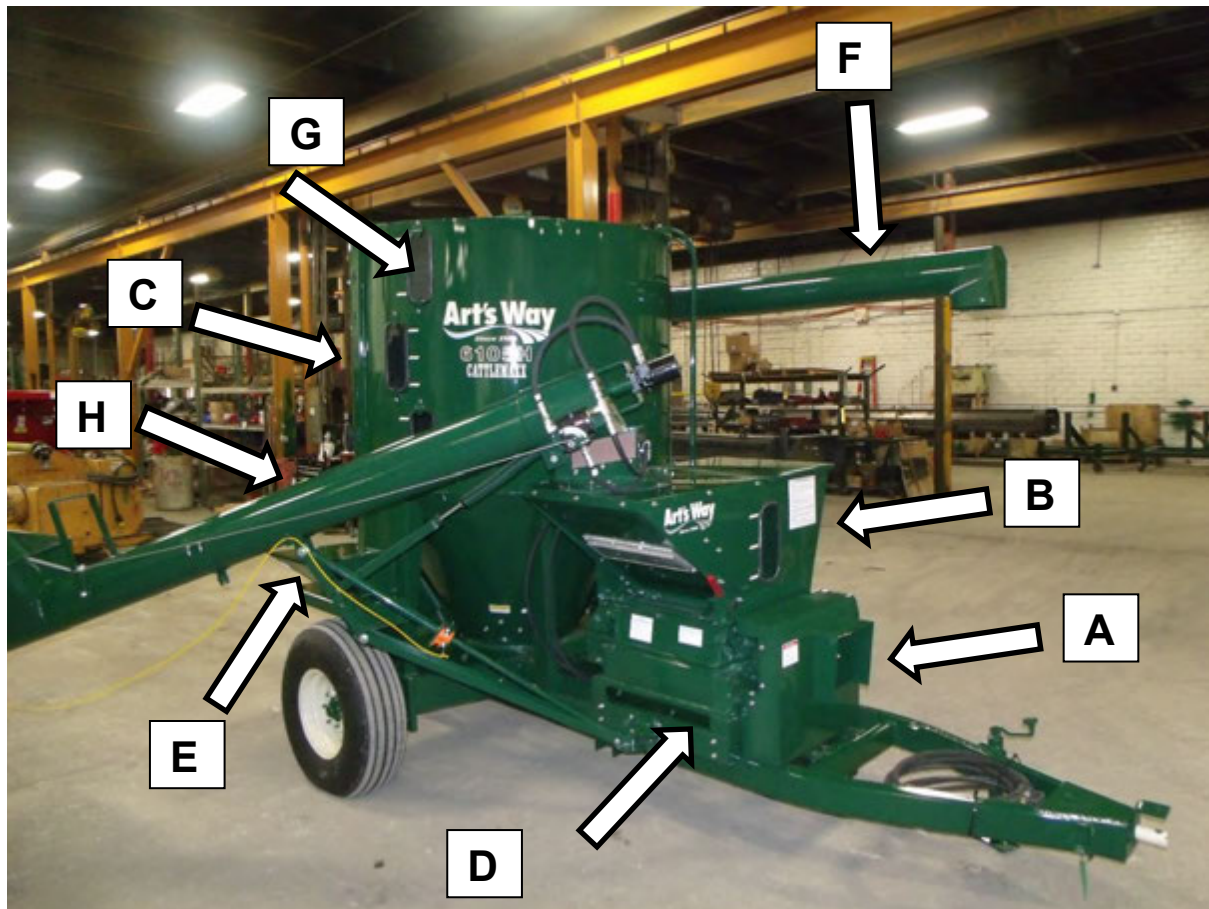

Figure 109 - CattleMaxx With Auger Feeder (A – PTO Driveline; B – Rollermill; C – Mixing Tank; D – Dust Collector; E – Supplement Hopper; F – Unloading Auger; G – Viewing Windows; H – Auger Feeder).

This manual has been prepared to make you familiar with the proper operation, adjustment, lubrication and service of your CattleMaxx. Take time to be careful and better understand the efficient operation and care of your machine.

Whenever the terms “*Left*” and “*Right*” are used, it should be understood to mean standing behind the machine and facing the direction of forward travel.

***Some pictorials are used to show guards, doors and shields removed for easy identification. Make sure that all guards, doors and shields are in place before operating the machine. They are for your protection.***

The Art’s-Way CattleMaxx is driven by a PTO driveline of 40 hp to 130 hp tractors and is factory available with a 540 RPM drive.

Always operate at full speed while rolling grain.



**CAUTION: NEVER OPERATE A 540 RPM PROCESSOR WITH A 1000 RPM TRACTOR.**

The rollermill (Figure 109, Detail B) is precision built of tough, cast iron construction, designed to give a high degree of control over the quality of feed produced.

It is important that you become acquainted with your rollermill before operating at full capacity. The rollermill will not start with grain between the rolls.

If supplement is to be added to the ration, a hopper (Figure 109, Detail E) with a sack cutter is located at the right rear of the mixing tank. The best mixing will result if the supplement is added before grinding.

The rolled feed is mixed continuously until the tractor PTO is disengaged.

The unloading auger (Figure 109, Detail F) pivots at the rear center of the mixing tank and can swing 324 degrees on the 6105 CattleMaxx or in a horizontal arc and in a vertical arc to the limit of the lift assist spring. The unloading auger tube can be positioned either to the right or to the left side of the tank for transport. Unloading rates up to 30 bushels per minute can be obtained depending upon

position of the discharge and the type of material processed.

Three viewing windows (Figure 109, Detail G) are located at the front right corner of the mixing tank and one window in rear of mixing tank to observe the feed level during grinding and mixing.

A ladder is located at the front left corner of the mixing tank along with a grab handle on top of tank to gain access to the spring-loaded mixing tank lid.



**CAUTION: DO NOT OPEN SPRING-LOADED MIXING TANK LID WHILE PTO IS ENGAGED AND TRACTOR IS RUNNING.**

Many convenient features are standard equipment on the Art's Way CattleMaxx including:

1. Heavy Duty 540 RPM implement driveline with shear clutch.
2. 20 inch heavy duty rollermill.
3. Roll scrapers
4. Rollermill hopper magnet system.
5. Feed inspection tube under rollermill.
6. Ingredient supplement hopper.
7. Tongue jack and safety chain.
8. Ladder and fenders.
9. Four large inspection windows in tank.
10. Spring loaded tank lid.
11. Hydraulic or mechanical positioning of discharge auger. This includes a hydraulic cylinder or mechanical crank for lift and hydraulic motor or mechanical crank for swing.
12. 8 inch diameter by 10 foot long unloading auger.
13. Discharge auger hood with spring loaded relief baffle.
14. 10.00 x 15 tires.
15. 29" vertical discharge.

Below is a list of optional attachments available:

1. Hydraulic auger feeder.
2. Electronic scale, with digital readout. Microprocessor model is also available.
3. Horn, light, or horn and light for electronic scale.
4. Unloading auger extensions; 3 ft. or 6 ft. folding or bolt-ons.
5. Highway transport light kit.
6. Mechanical or hydraulic lift and swing.
7. Roll speed differential drive rollermill.
8. Hydraulic Discharge (Tractor Operated) designated with an H behind model number (i.e. 6105H).

## PREPARING THE CATTLEMAXX FOR OPERATION

Remove the shipping banding or wire from the auger feeder (if equipped), rear discharge cover and the unloading tube to saddle at the side of the tank.

Remove the bag from the supplement hopper. A wrench is provided for adjusting the roll gap spacing of the roller mill. Keep this wrench with the mill at all times. If equipped with mechanical lift and swing, the crank for the unloading auger is in the bag. Place it in the hanger near the crank position for lift and swing. Install the PTO driveline storage bracket under front hitch with 1/2 inch X 1-1/2 inch bolt and lock nut. (See Figure 110). Maintain tension with lock nut to allow movement with 15 lbs. pull.



**Figure 110 - PTO Driveline Storage Bracket.**

Install any option that was ordered with the machine and shipped as loose equipment. See package instructions with the specific options for installation.

Install the implement end of the PTO driveline by fastening it to the input jackshaft with the 5/16 inch X 3-1/2 inch clevis pin and cotter pin provided. Spread the cotter pin and make sure the proper PTO is used.



**CAUTION: NEVER OPERATE A 540 RPM CATTLEMAXX WITH A 1000 RPM TRACTOR.**

**NOTE:** Height of the unloading auger tube needs to be checked. Move the saddle on the side of the mixing tank so the tube will properly clear the tractor and cab. This is especially important with bolt-on auger extension.

If equipped with a tractor hydraulic auger feeder or roll feed, refer to page 17 and page 18 for additional instructions

### TIRES

Keep tires properly inflated. Lack of pressure can result in torn valve stems, fabric breaks and uneven

tread wear. Too much pressure can cause undue strain on fabric, excessive tread wear and allows the tire to cut in more on wet surfaces. Equal tire pressure reduces CattleMaxx sway when towing.

Recommended tire inflation pressure is as follows:

10.00 x 15      8 – PR tires – 40 psi      6105 CattleMaxx

### SHIELDS

Make sure that all shields are in place and functioning.

### BOLTS AND NUTS

Before starting to operate the CattleMaxx check all nuts and bolts for tightness. Also check that all cotter pins are spread. After operating the CattleMaxx for several hours, check all the bolts for proper torque. Refer to the torque guide. (See Table 6)

Size	Clamp Load	Plain GR 5	Plated GR 5
1/4 – 20 (.250)	2,025	8 ft. lbs.	76 in. lbs.
5/16 – 18 (.3125)	3,338	17 ft. lbs.	13 ft. lbs.
3/8 – 16 (.375)	4,950	31 ft. lbs.	23 ft. lbs.
7/16 – 14 (.4375)	6,788	50 ft. lbs.	37 ft. lbs.
1/2 – 13 (.500)	9,075	76 ft. lbs.	57 ft. lbs.
9/16 – 12 (.5625)	11,625	109 ft. lbs.	82 ft. lbs.
5/8 – 11 (.625)	14,400	150 ft. lbs.	112 ft. lbs.
3/4 – 10 (.750)	21,300	266 ft. lbs.	200 ft. lbs.
7/8 – 9 (.875)	29,475	430 ft. lbs.	322 ft. lbs.
1 – 8 (1.00)	38,625	644 ft. lbs.	483 ft. lbs.
1-1/8 – 7 (1.125)	42,375	794 ft. lbs.	596 ft. lbs.

**Table 6 - Torque Specification Guide for Grade 5 Bolts.**

Cap screws, except for shear bolts, used on the grinder mixer are Grade 5 and if replaced, cap screws of equal or greater strength should be used. Grade 5 cap screws are identified by three radial dashes on the hex head. Refer to the SAE bolt identification guide. (See Figure 111)

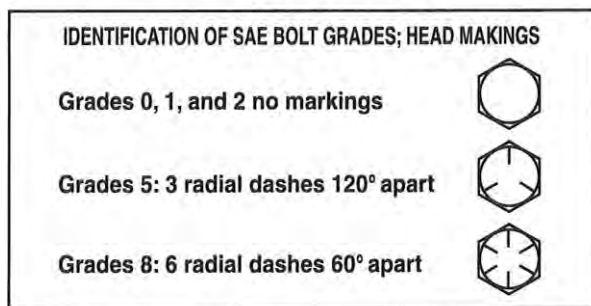

Figure 111 - SAE Bolt Identification.

**IMPORTANT:** Shear bolts must be replaced with bolts of the same grade. See "Service" section on page 88.

Lubricate the CattleMaxx at regular intervals as instructed in the lubrication sections. (Refer to the LUBRICATION section page 83)

**PREPARING THE TRACTOR**

The tractor must be equipped with a 540 RPM PTO to match the CattleMaxx as described in the previous section. Make sure the CattleMaxx and the tractor are equipped and set for the proper RPM.

**CAUTION: NEVER OPERATE A 540 RPM CATTLEMAXX WITH A 1000 RPM TRACTOR PTO.**

**TRACTOR HITCH**

The hitch for the CattleMaxx is designed to attach to any SAE – ASAE standardized tractor drawbar. Adjust the drawbar so it is 13 to 17 inches above the ground (See Figure 112). Extend or shorten the tractor drawbar so the horizontal distance from the end of the tractor PTO shaft to the center of the hitch pin hole is 14 inches for 540 RPM drives.

Lock the drawbar in its crossbar, parallel with the centerline of the PTO. Place locking pins on each side of the drawbar. If the tractor has an offset drawbar, the offset should be down for PTO work.

**IMPORTANT:** An improperly located hitch point may cause damage to the universal joints (U-Joints) of the PTO driveline.

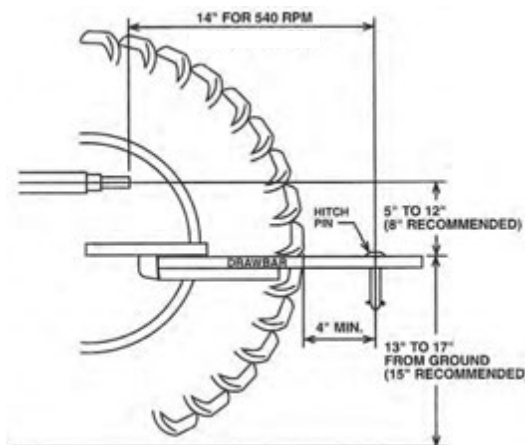

Figure 112 - Hitch Point Locations

**ATTACHING TO THE TRACTOR**

**NOTE:** Height of the unloading auger tube needs to be checked. Move the saddle on the side of the mixing tank so the tube will properly clear the tractor and cab.

Carefully back the tractor up to the hitch. Use the crank of the jack to raise or lower the CattleMaxx hitch into position to engage the tractor drawbar.

Fasten the CattleMaxx hitch to the drawbar with a hitch pin that cannot bounce out. Raise the jack and lock into the transport position (See Figure 113). Attach the safety chain from the grinder mixer to the tractor (See Figure 114).

**CAUTION: ALWAYS FOLLOW STATE AND LOCAL REGULATIONS REGARDING A SAFETY CHAIN WHEN TOWING FARM EQUIPMENT ON PUBLIC HIGHWAYS.**



Figure 113 - Jack in Transport Position



**Figure 114 - CattleMaxx Attached To The Tractor With Safety Chain.**

If the CattleMaxx is equipped with an electronic scale, plug the scale power supply cord into the electrical outlet on the tractor or to the battery on the CattleMaxx frame.

**IMPORTANT:** On electronic scale applications, if a bolt and nut are used in place of a hitch pin, the nut must not be tightened to where it hits against the underside of the weigh bar clevis.

If the CattleMaxx is equipped with a tractor hydraulic function, install the proper male ends on the hoses and plug the hydraulic line hoses into the tractor outlets. Refer to [page 81](#) for open and closed center instructions.

Connect the PTO driveline to the tractor PTO shaft. The PTO operating speed of the tractor and CattleMaxx must be the same. The tractor half of the PTO is equipped with 6 splines for 540 RPM operation.



**CAUTION: NEVER OPERATE A 540 RPM GRINDER MIXER WITH A 1000 RPM TRACTOR.**

After connecting PTO driveline to tractor, anchor driveline implement shield chain in main shield base slot and the tractor shield chain to the tractor drawbar.

### **ROLLERMILL**

Check that the rollermill feed control gate is closed and remove any debris on top of the gate. The rollermill will not start if there is any material or debris in the rolls (See Figure 115).

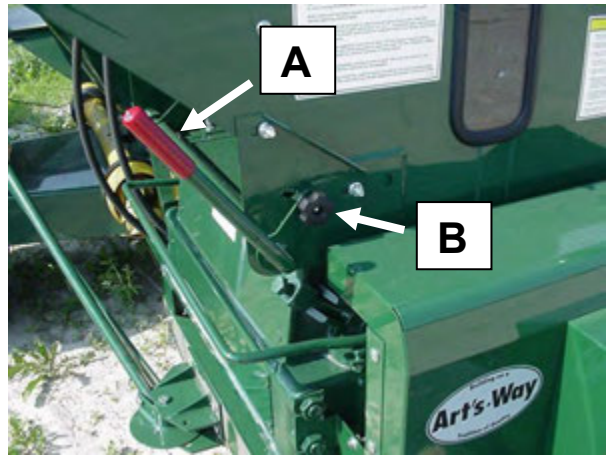

**Figure 115 - Rollermill in Closed Position (A - Gate Lever; B - Gate locking Knob).**

### **BEFORE PROCESSING**

New machines should be operated before preparing feed. A few hundred pounds of coarse material such as shelled corn or ground cobs should be ran through the grinder mixer. This will remove the protective oil coating from the mixer cone and any metal particles that may be in the machine. This will help polish the cone and prevent bridging. After several minutes of running the grinder mixer, unload the mixture and discard. **Do not feed this mixture to the livestock.**

### **DETACHING FROM THE TRACTOR**



**CAUTION: MAKE SURE THE TRACTOR IS SHUT OFF, REMOVE THE KEY AND PLACE THE KEY IN YOUR POCKET.**

Disconnect the PTO driveline and front shield anchor chain from the tractor and place it on the PTO driveline support bracket (See Figure 116). The PTO driveline support should be tight enough to remain in position when rotated from storage against the frame to use position.

Disconnect the electronic scale power cord from the tractor (if equipped).

Disconnect the hydraulic hoses from the tractor outlets (if equipped with tractor hydraulic functions).

Make sure the discharge auger and the auger feeder are in their saddles before disconnecting.

Block the tires. Lower the jack stand to the ground. Turn the handle of the jack stand to raise the



CattleMaxx tongue off of the tractor hitch. Remove the hitch pin and safety chain.



**Figure 116 - PTO Support.**

## OPERATION OF CATTLEMAXX



**CAUTION: KEEP WELL CLEAR OF MOVING PARTS. BEFORE RUNNING THE CATTLEMAXX, KEEP ALL CHILDREN AND BYSTANDERS AWAY FROM THE MACHINE.**

### TRACTOR PTO ENGAGEMENT

The CattleMaxx may be operated by engaging the PTO. Always engage the tractor PTO with the tractor engine at idle speed. After the PTO is engaged, increase the engine speed gradually until the desired operating speed is obtained. Reverse the PTO engagement steps to disengage the PTO.

Before processing, position the tractor straight with the frame of CattleMaxx. This will allow smoother PTO operation and prolong PTO driveline life.

**IMPORTANT:** If mixing while in transport, avoid sharp and unnecessary turns that may damage the PTO driveline.

The CattleMaxx does not have a main drive clutch, so the rollermill, supplement hopper auger and mixing tank auger will run whenever the tractor PTO is engaged. The unloading auger will only operate when the unloading auger clutch is engaged.

### PROCESSING

A rollermill processor is designed to process grains without the fines and deviations in particle size experienced with hammermills. However, a rollermill is limited in capacity compared to a hammermill in that the rate of feed processing is restricted by the roll gap and roll selection, and more horsepower will not increase capacity of the mill. It is important that you become familiar with the rollermill before operating it at full capacity.

All projected particle sizes will vary depending on the quality and moisture content of the grain, roll gap, power input, roll speed differential drive, and the general operation of the mill.

Always operate the rollermill at full speed (540 RPM) when processing. Slower speeds will increase power requirements and may cause damage or excessive wear to mill components.

### ROLLERMILL

The rollermill drive is a direct drive without a drive clutch, so the rolls will turn at all times. The drive consists of a direct driven drive roll, which drives the eccentric (Adjustable) roll and hopper agitator shaft through a rear belt drive. Always start and stop the CattleMaxx at low speeds so as not to damage any drive components.

To operate the rollermill, engage the tractor PTO at a low RPM and increase speed to the full rated 540 RPM. Start to fill the hopper with grain, allowing the full width of the hopper to fill to just above the magnet before operating the grain control gate. Open the grain control gate to the desired opening and lock the knob (See Figure 117). When processing is complete, allow the hopper to empty completely and close the grain control gate fully, locking the knob to keep the gate closed. Stop the rollermill and disengage the PTO at a low RPM only after the grain control gate has been closed and all grain in the rollermill has been processed.

**IMPORTANT:** Never stop the rollermill with grain in the rolls. The rollermill will not start if any grain is wedged in the apex of the rolls.

The rollermill will not start if there is any material between the rolls. If material does get into the rolls without the PTO engaged, the roll gap must be opened or the material cleaned from the rolls before the rolls can be turned.

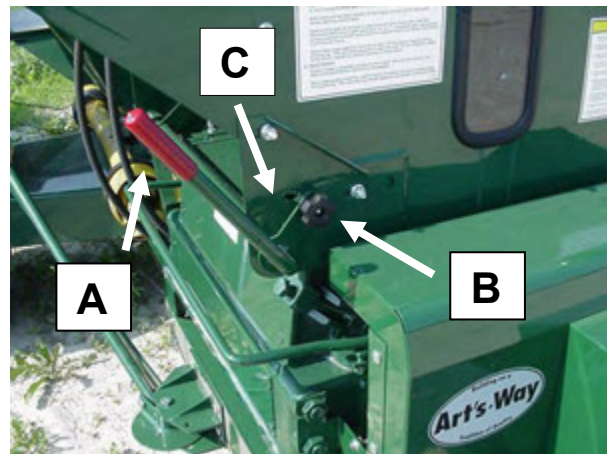

**Figure 117 - Grain Control Gate Operation (A - Gate Lever; B - Gate Locking Knob; C - Lever Gauge).**

### DRIVELINE PROTECTION

The CattleMaxx driveline is protected from overloading by a shear clutch located at the end of the PTO driveline on the drive roll (See Figure 118). Always replace the shear clutch bolt with a metric M10-1.5 x 60 bolt. Use of any other type or size of shear bolt will compromise the driveline protection of the machine.



Figure 118 - PTO Driveline Shear Clutch

### HOPPER MAGNETS

Two plate magnets are located in the hopper above the rollermill (See Figure 119). Always load the hopper from the right-hand side to utilize these magnets. A magnet assembly is also located in the hopper throat just above the rollermill rolls. This is standard equipment on all machines to help protect the mill from tramp metal. It is important to keep the magnets clean and monitor their condition.

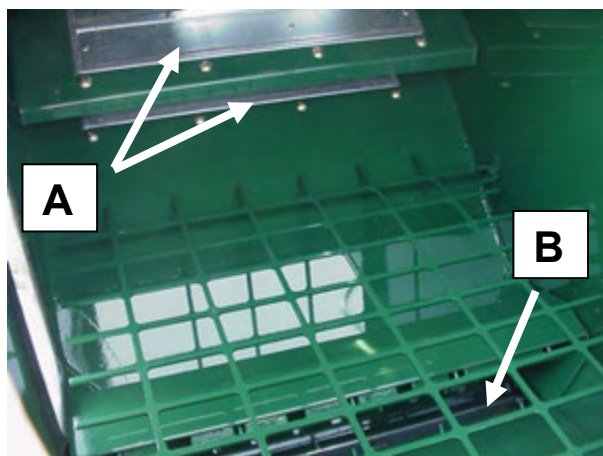

Figure 119 - Plate Magnet in Hopper (A - Plate Magnets; B - Throat Magnet).

### GRAIN CONTROL GATE

The grain control gate is used to regulate the flow of grain into the rollermill. The grain control gate

lever is located at the front right corner of the mill (See Figure 120). To adjust the grain control gate, loosen the knob and push or pull the lever to close or open the gate. Each slot on the grain control gate lever gage is approximately 0.25 inch of gate opening. Tighten the knob to hold the gate in place once the desired opening is set.

Open the grain control gate after the rollermill has been started and the hopper as about half full (grain showing in the hopper inspection window). Open the control gate enough to allow a smooth grain flow into the rollermill. Recommended control gate opening is 0.5 inch to 1.0 inch. A high grain flow rate will cause grain to boil on top of the rolls and decrease capacity of the rollermill.

**IMPORTANT:** The grain control gate should be opened only enough to provide the rate of processing required, with a maximum gate opening of 1.0 inch.

Opening the grain control gate more than 1.0 inch will overload the mill and cause mill vibrations, and also result in lower capacity, larger grain particle size, undo drive stress, shortened roll life, and excessive power requirements. When the CattleMaxx is operated for the first time, the feed rate from the auger feeder or bin should be restricted until you become acquainted with the capacity of the unit.

Always ensure that the grain control gate is closed during transport or when not in use. This will prevent material from falling into the apex of the rolls and preventing the rollermill from starting.

### ROLL GAP

Roll gap is the space between the rollermill rolls, which is used to control the particle size of the rolled feed. A roll gap of 0.010 inch is set at the factory and should never be set less than 0.008 inch. This setting is determined by the adjustment of the eccentric roll handle stops (See Figure 120). Use this minimum setting for fine processing and open the roll gap for coarser processing. Use the pointer on the front bearing housing of the eccentric roll for wider roll gap setting reference.

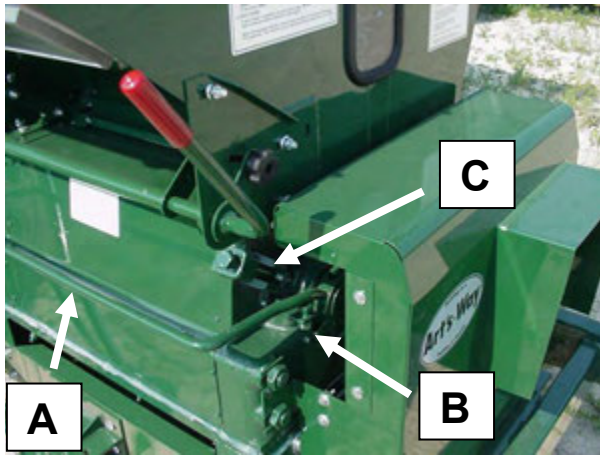

**Figure 120 - Eccentric Roll Settings (A - Eccentric Handle; B - Eccentric Handle Stops; C - Eccentric Roll Lock Bolt).**

The minimum roll gap on the roller mill must be maintained to ensure a consistent particle size. This should be monitored as the rolls wear and will also need to be adjusted for any replacement or re-grooved rolls.

Roll gap should be set for each type of grain. It is not recommended to process mixed grains as greater particle size deviation will occur. You are encouraged to experiment with the roll gap setting to meet the requirements of rolling different grains in your operation. Particle size can be monitored by using the grain inspection trough under the left-hand side of the roller mill to take feed samples (See Figure 121).



**Figure 121 - Grain Inspection Trough.**

Be careful not to over roll grains with too small of a roll gap setting on the roller mill. Over rolling takes more power, reduces capacity, and causes unnecessary roll wear. The roller mill should be ordered with the rolls grooved for the smallest grains to be rolled.

Be careful when adjusting the roll gap to always pull on the eccentric roll handle evenly, either from both ends or from the center. Do not pull up on the eccentric roll handle from only one end, as twisting or bending the handle will move one of the eccentric roll more than the other and cause the rolls to become out of parallel with each other. Parallel rolls must be maintained to achieve uniformity in the feed particle size.



**CAUTION: NEVER ADJUST THE ROLL GAP WHILE THE CATTLEMAXX IS RUNNING.**

The roller mill is equipped with a positive pressure eccentric roll release to automatically open the gap between the rolls. This is to minimize damage to the rolls and drive train from the induction of tramp metal or other foreign objects into the rolls. Opening the grain control gate too far and overloading the rolls can also cause the eccentric roll release to trip. Indications that the eccentric roll release has been tripped are a sudden higher particle size in the processed feed and the eccentric roll handle has moved up. The eccentric roll release must be reset if this occurs.

The eccentric roll release is set by tightening the eccentric lock bolts after the eccentric roll handle has been positioned for desired roll gap (See Figure 120). The lock bolts tighten down on a brass plug, which pushes against a knurled surface on the eccentric roll bearing housing. Excessive pressure between the roll will shear the brass plug and open the roll gap.

Do not over-tighten the eccentric lock bolts, as this will render the eccentric roll release ineffective. Tighten the eccentric lock bolts only until they are snug. Use only the wrench provided to tighten the eccentric lock bolts so as not to over torque the bolts.

### **ROLLERMILL ROLLS**

The roller mill rolls in the CattleMaxx are made of heat treated cast iron. The rate of wear on the roll is dependent upon the hardness or abrasiveness of the grain, the amount of overloading done, and damage resulting from foreign objects such as tramp metal, stones, etc. Increase in particle size and horsepower requirements are signs of increased roll wear. Rolls should be replaced when they become worn down and the surface is slick and shiny.

Worn rolls can be re-grooved and re-heat treated by Art's-Way. Refer to the "Service" section of this manual for information on replacement rolls.

## ROLL SELECTION

Rollermill rolls can be purchased with either a sharp or flat groove cut. The sharp groove rolls offer a higher capacity and finer particle size while the flat groove rolls are for flaking or cracking grains.

Rollermill rolls can be cut with 5, 7, or 10 grooves per inch. The 10 groove roll will take any small grain and is recommended for wheat, milo, barley, oats, etc. The 7 groove roll will also take these small grains as well as shell corn, however the smaller kernels may pass through the rolls uncracked. It is suggested to use a combination of one 7 and one 10 groove roll when using multiple grains such as corn and milo. The 5 groove roll is recommended for use with shell corn. The coarser groove rolls will have a higher capacity than the fine groove rolls (See Table 7).

When using roll combinations with different grooves (sharp to sharp or flat to flat) the coarser grooved roll is the drive roll. When combining sharp and flat rolls with the same number of grooves, the drive roll is the sharp roll.

Capacity of the roller mill is dependent upon the roll selection as well as the roll gap, roll speed differential, condition of the rollermill, and quality of material.

Rolls	Material	Aprox. Bu./Hr.
10 Groove	Oats	200 to 300
	Wheat/Barley	200 to 300
	Milo/Corn	300 to 400
7 Groove	Milo/Corn (Dry)	350 to 450
	Milo/Corn (Hi)	300 to 400
5 Groove	Milo/Corn (Dry)	400 to 600
	Milo/Corn (Hi)	350 to 550

Table 7 - Roll Capacity Chart

## ROLL SPEED DIFFERENTIAL

Your CattleMaxx rollermill may be equipped with a belt driven roll speed differential. This increases the speed of the eccentric roll, which causes a scrubbing effect on the rolls helping to keep them clean. The CattleMaxx rolls should be equipped with a roll speed differential if high moisture grain is to be used. A roll speed differential has also been found to decrease particle size and increase capacity of the rollermill.

## ROLL SCRAPERS

The CattleMaxx rollermill is equipped with roll scrapers to help prevent material from packing onto the rolls. With coarse or dry material, the spiral design of the roll groove cut keeps the rolls clean and roll scraper setting is not as critical. For fine or high moisture material, a higher tolerance roll scraper setting should be maintained. Allowing material to build up on the rolls will cause a loss of capacity and excess load on the drive components.

Roll scraper setting needs to be monitored as the rolls wear and should be adjusted after changes in a minimum roll gap setting or when replacing rolls. The main drive roll scraper should be set at 0.006 inch clearance and the eccentric roll scraper should be set at 0.050 inch clearance.

## PROCESSING WITHOUT MIXING

To process any material without mixing, engage the unloading auger lever, open the tank unloading auger door and start the processing operation.

The feed will be augered into the mixing tank cone and then out through the unloading augers without mixing. Position the unloading auger tube as needed to direct the feed.

## ADDING CONCENTRATE OR SUPPLEMENT

Concentrate or supplement should be added to the ground feed through the supplement hopper located at the right rear corner of the CattleMaxx (See Figure 122). A serrated sack cutter is located in the hopper opening. A grate is positioned below the sack cutter to keep the bag from falling into the auger.

***For best results, add the concentrate or supplement before grinding operation. Do not add ingredients to the supplement hopper while grinding, this will over load the auger.***



Figure 122 - Supplement Hopper On Right-Hand Side Of Machine.



**CAUTION: KEEP HANDS AND FEET CLEAR OF AUGER. MAKE SURE GRATE IS ALWAYS IN PLACE.**

Addition of very fine ingredients or commodities that do not need to be processed should be added to the mixer either through the supplement hopper or through the roller mill with an increased roll gap. Fine ingredients or commodities will tend to pack onto the rolls set with a narrow roll gap and may cause the eccentric roll release to trip if the roll gap is less than the roll scraper clearance.

If micro-ingredients are to be added to the feed, the best results are obtained with a pre-mix, or by adding the supplements and micro-ingredients at the same time. If the micro-ingredients are desired without a pre-mix or other supplement, open the mixing tank lid and add the ingredients directly into the mixer. This should be done at the beginning of the operation. Make sure to close the lid before starting the operation. The supplement hopper lid should always be closed when not in use.

If strong additives are not desired in the batch that follows, clean out the tank cone and unloading augers through the clean-out doors (See Figure 123).



**CAUTION: MAKE SURE THE PTO IS DISENGAGED AND THE TRACTOR IS SHUT OFF. PLACE THE KEY IN YOUR POCKET BEFORE OPENING OR CLOSING THE CLEAN-OUT DOOR.**



**Figure 123 - Tank Cone Clean-Out Door On Right-Hand Side.**

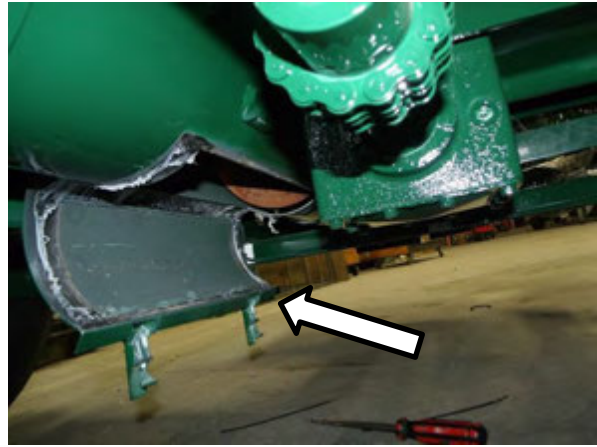
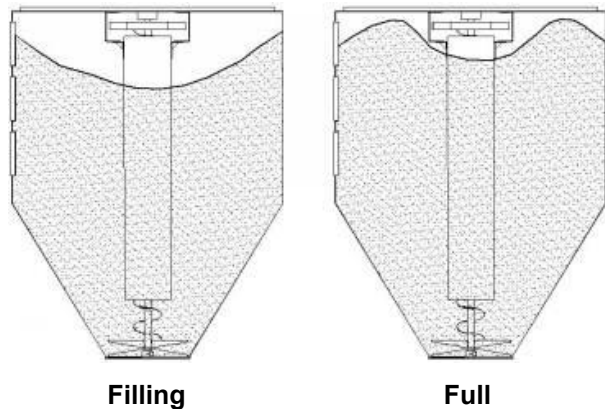

**Figure 124 - Clean-Out Door Located Under Right-Hand Side Of Tank Assembly.**

Located under the right-hand side of the frame and tank assembly is a hinged door on the bottom of the auger trough. Release two spring clamps and allow door to drop. Keep away from the opening. Run the mixer slowly until the trough and the mixing tank are cleaned out. Keep all bystanders away from the machine.

### **FILLING THE MIXER TANK**

Make sure the mixing tank unloading door is closed. As the mixing tank is filling, watch the ground feed through the mixing tank windows. If the top window is covered, this does not mean the tank is full as the mixing auger throws material away from the center of the tank. Continue loading until the top window clears (feed drops) and then becomes covered again about half-way (See Figure 125). Stop feeding material into the processor at this point, but continue operating until the processor has had time to clear. ***Do not overload the mixer.*** An overload can cause damage to the machine. To estimate the number of bushels that are in the tank, refer to Table 3.



**Figure 125 - Filling pattern**

For the best mixing results, always add lightweight bulky materials first. Always add high moisture corn

or grain last. Excessive amounts of wet or bulky material may cause *bridging* in the mixing tank.

**105 BU. – APPROXIMATE CAPACITY CALIBRATION – IN POUNDS\***

Actual weights may vary due to material, moisture, and screen size. Ration weight is not included and is variable.

Window Position	Ground Oats 22.5 lbs/bu	Ground Barley 36 lbs/bu	Ground Milo 56 lbs/bu	Ground Shelled Corn 50 lbs/bu	Ground Ear Corn 38 lbs/bu	Un-ground Shelled Corn 56 lbs/bu
Full	2346	3754	5839	5213	3962	5839
9	2219	3549	5521	4930	3747	5521
8	2046	3274	5092	4547	3456	5092
7	1874	2998	4664	4164	3165	4664
6	1659	2654	4129	3687	2802	4129
5	1487	2379	3701	3304	2511	3701
4	1315	2103	3272	2921	2220	3272
3	1100	1760	2737	2444	1857	2737
2	928	1484	2038	2061	1566	2038
1	756	1208	1880	1678	1276	1880

**NOTE:** \* Above weights are approximate and are to be used as a guide only. Variations may occur due to test weight of grain, slope of machine, moisture content, or screen size. For best ration control use an electronic scale.

Table 8 – Tank Capacity for 6105 (105 bu).

### **SPRING LOADED TANK LID**



**CAUTION: DISENGAGE ALL THE DRIVES. SHUT OFF THE TRACTOR ENGINE AND PLACE THE KEY IN YOUR POCKET BEFORE OPENING THE MIXING TANK LID.**

If the mixing tank is accidentally overfilled, it is equipped with a spring loaded tank lid (See Figure 126). The lid also allows access to the inside of the mixing tank. Keep the lid closed and latched at all times.



**CAUTION: IF ENTERING THE TANK, MAKE SURE THE TRACTOR ENGINE IS SHUT OFF. PLACE THE KEY IN YOUR POCKET AND DISCONNECT THE PTO DRIVELINE.**



Figure 126 - Spring Loaded Tank Lid.

After the processing is completed and the desired ration is in the mixing tank, allow the mixer to operate until it is ready to unload. Run the mixer 2 to 3 minutes to ensure the feed and supplements have been thoroughly mixed.

**IMPORTANT:** Avoid sharp and unnecessary turns that may damage the PTO driveline during transport.

### **UNLOADING AUGER POSITIONING**

After mixing, the finished feed may be unloaded into storage bins, wagons, or feeders. Positioning (Lift and Swing) of the unloading auger and drive for the unloading auger may be controlled in two ways: Manual Crank or Tractor Hydraulic Lift and Swing.



### Manual Crank

Insert crank on the shaft next to channel to lift and on the shaft at the rear of lower auger housing to swing the unloading auger (See Figure 127 and Figure 128). A brake is provided to prevent movement after positioned (See Figure 129).

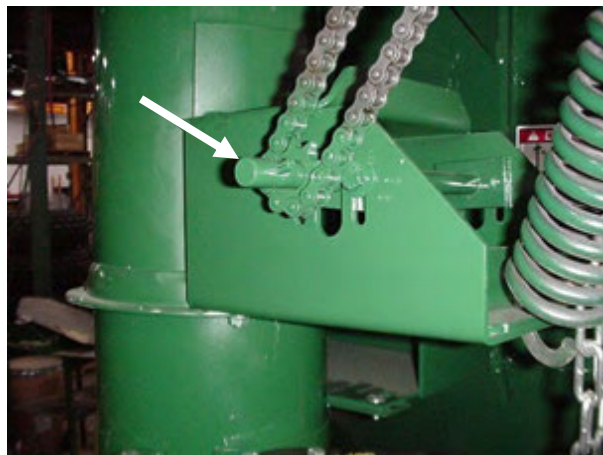

Figure 127 - Manual Lift



Figure 128 - Manual Swing



Figure 129 - Manual Brake

### Tractor Hydraulic Lift and Swing

Hydraulic lift and swing is accomplished by using the hydraulic system valves. If a hydraulic auger feeder is present, a double selector valve is required to direct flow of the hydraulic fluid. Either the swing motor or the auger feeder may be operated independently but not at the same time. (See Figure 130) Position the selector valve control "IN" to direct fluid to discharge the swing function. Make sure spool goes fully against the snap ring when moving lever in.



Figure 130 - Hydraulic Selector Valve (Lever in the In Position - Hydraulic Swing).

Connect four hydraulic hoses with the appropriate male connectors to the tractor. Make sure the proper hoses are connected to the same tractor hydraulic circuit. Activate the appropriate tractor valve to lift the unloading auger, then use the other hydraulic valve to swing the unloading auger to the desired position.

### UNLOADING AUGER ENGAGEMENT

Operate the tractor at a minimum of 2/3 throttle for unloading. This allows the discharge augers to move the feed through the discharge elbows more efficiently with lower driveline stress.

### UNLOADING CLUTCH DRIVE

Starting at an idle, move the clutch handle ahead and down to engage the augers. (See Figure 131). Gradually increase speed to at least 2/3 throttle. Open the unloading door. The eccentric may be used to hold the door open (See Figure 132). When the tank is unloaded, reverse the procedure.

If unloading in more than one location, close the discharge door and empty the auger before transporting the CattleMaxx. Transporting or adjusting the discharge auger height with material in the discharge auger will cause excessive wear to the ring and worm gear assembly and discharge auger system.

If equipped with optional hydraulic discharge (6105H models), clutch is NOT installed.



Figure 131 - Unloading Clutch Operation.

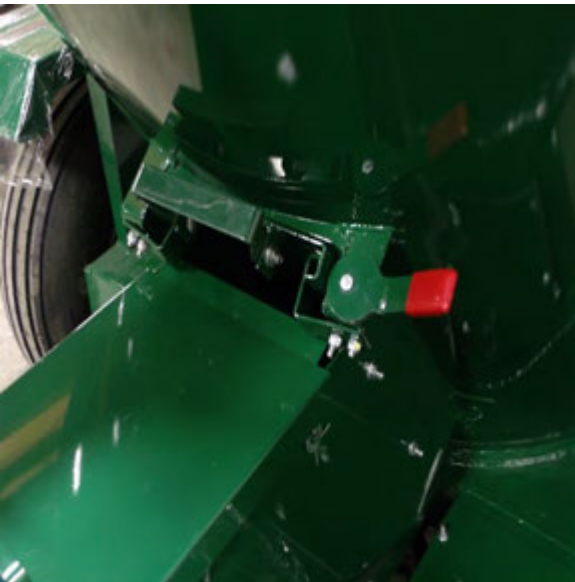

Figure 132 - Unloading Door (A - Eccentric Lock).

### **Hydraulic Discharge (6105H Models Only)**

Connect two hydraulic discharge hoses to desired hydraulic circuit on tractor. Hoses come installed with Pioneer™ style male quick connectors from factory (See Figure 133).

Slowly engage the hydraulic discharge with tractor. Gradually increase speed to at least 2/3 throttle to reduce the risk of bogging down machine or potentially plugging an auger. Open the unloading door. The eccentric may be used to hold the door open (See Figure 132).

When the tank is unloaded, reverse the procedure. Always make sure that discharge is empty before transporting mixer.

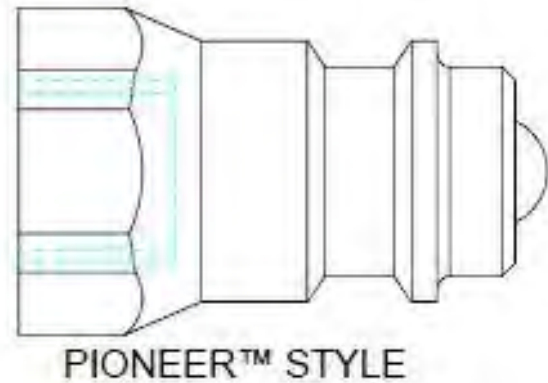

Figure 133 - Hydraulic Quick Connector.

### **FOLDING AUGER EXTENSION**

Optional extensions for the unloading auger include a 3 to 6 feet folding or bolt-on extension. (See Figure 134). For discharge heights of the optional extensions (See Figure 135).

If the CattleMaxx is equipped with a folding auger extension, make sure the outer auger drive cog is properly engaged and the extension tube is locked before engaging the unloading clutch.

Always make certain that a bolt on auger extension will clear the tractor cab during transport. Folding augers extensions should be in the folded position for transport.



Figure 134 - Folding Auger Extension.

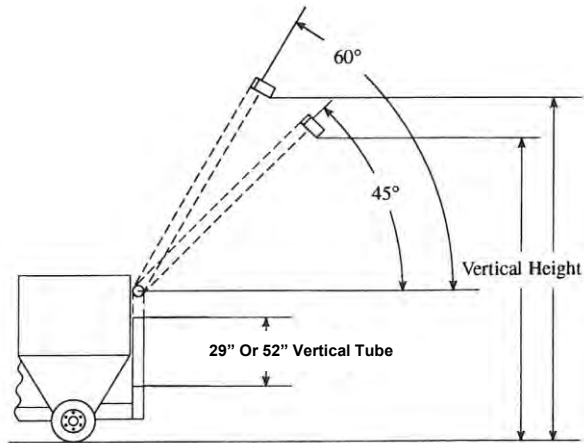

**Figure 135 - Unloading Auger Heights (Refer To Table 9 for Detailed Heights.)**

### **UNLOADING AUGER HOOD**

When the unloading auger tube becomes overloaded, a spring loaded door opens on the end to prevent damage to the drive. (See Figure 136).



**Figure 136 - Unloading Auger Hood.**

Unloading Auger Configuration	Tube & Elbow Combined Length	Discharge 45°		Discharge 60°	
		29" Tube	52" Tube	29" Tube	52" Tube
<b>105 Bu.</b>					
Standard - No Extensions	125 in.	14 ft 19 in	N/A	16 ft 8 in.	N/A
3 ft. Fold Around Auger Extension	161 in.	17 ft 0 in.	N/A	19 ft 3 in.	N/A
6 ft. Fold Around Auger Extension	197 in.	19 ft 8 in.	N/A	22 ft 0 in.	N/A

**Table 9 - Unloading Auger Heights**

### **AUGER FEED OPERATION**

**NOTE:** The CattleMaxx may be equipped with a hydraulic auger feeder.

To position the auger feeder, remove the clip pin from the fender bracket and lift the bottom of the auger feeder slightly so the brackets can clear the fender. Swing the auger feeder outward, away from the tank to ensure it will clear the fender when it is lowered. Lift the auger feeder slightly and pull the rope on the right hand side to disengage the height adjustment ratchet bar. Raise or lower to the desired height and release the rope.



**DANGER: TO PREVENT PERSONAL INJURY:**

4. **USE THE GRATE OVER THE AUGER WHENEVER POSSIBLE**
5. **KEEP HANDS AND FEET OUT OF THE HOPPER AREA AND DO NOT CLIMB ON OR OVER THE HOPPER AT ANY TIME.**
6. **KEEP CHILDREN AND BYSTANDERS AWAY FROM THE MACHINE WHILE THE MACHINE IS IN OPERATION**



**Figure 137 – Cattlemaxx Auger Feeder**

The auger feeder swing brake prevents the auger from swinging. Tighten or loosen as desired (See Figure 138).

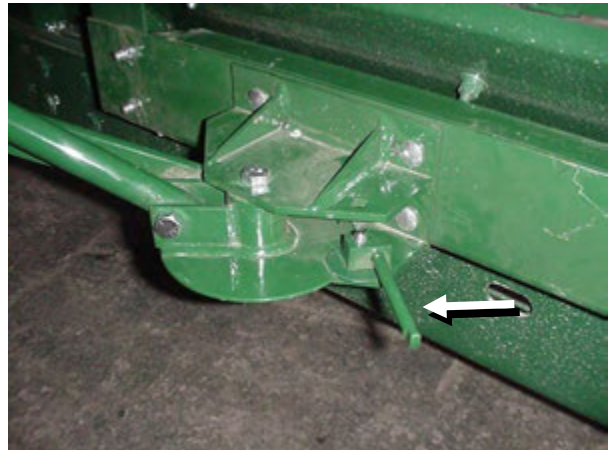

**Figure 138 - Auger Feeder Swing Brake**

**NOTE:** If the machine is equipped with an electronic scale, to obtain a more accurate reading, **DO NOT** rest the auger feeder on the ground. Place it in the desired position and set the swing brake (See Figure 138).

The auger feeder is counter balanced by a spring (See Figure 139). Adjust the spring by loosening the nut on the lower bolt, turn the bolt in to increase the spring tension, and relock the nut.



**Figure 139 – Auger Feeder Counter Balance Spring**

Shut off handles are provided at the auger feeder hopper and at the flow control valve at the top of the auger feeder housing. To shut off the auger feeder pull the handle at the hopper area or move the flow control lever to off (See Figure 140 and Figure 141). Make sure the shutoff handle at the hopper will stop the auger feeder. Loosen cable clamps to readjust.

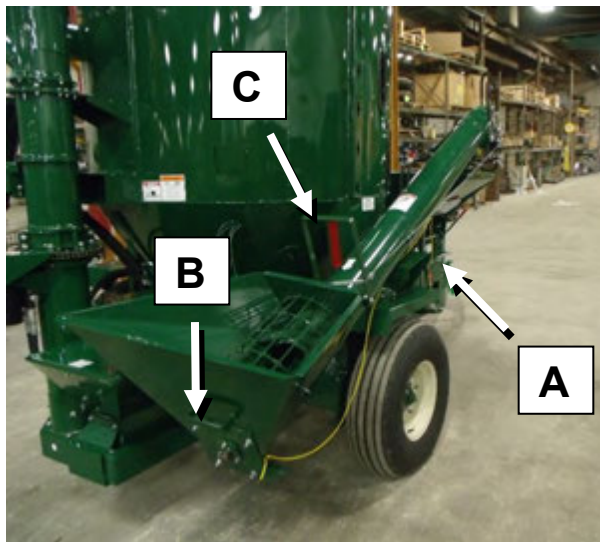

**Figure 140 - Auger Feeder Positioner And Spring Adjustment (A - Spring; B - Positioner Handle; C - Positioner Lock).**



**Figure 141 - Auger Feeder Flow Control Valve (Shown In "ON" Position).**

For the tractor hydraulic auger feeder (when equipped with a hydraulic lift and swing unloading auger), a selector valve will be located to the left rear side of the processor. The handle on this valve must be out to divert the oil to the auger feeder.

If the handle for the selector valve is in, oil flows to the swing function of the unloading auger. (See Figure 141)



**Figure 142 - Hydraulic Auger Feeder Selector Valve Lever Is In The *Out* Position - Auger Feeder).**

To start the auger feeder, the flow control handle is moved forward (clockwise) until the desired speed is reached.

Adjust the speed of the auger feeder to keep the roller mill hopper about half full or the grain level visible through the hopper inspection window (See Figure 143). Under filling the hopper will cause uneven roll wear and higher particle size deviation while over filling the hopper will cause the hopper plate magnets to be covered with material and making them ineffective.



Figure 143 - Hopper Inspection Window.

## GRINDER MIXER ADJUSTMENTS



**CAUTION: DO NOT MAKE ANY ADJUSTMENTS WHILE THE MACHINE IS IN OPERATION. BE SURE TO SHUT OFF THE TACTOR AND PLACE KEY IN POCKET WHILE MAKING ADJUSTMENTS. WAIT FOR ALL MOVEMENT TO STOP BEFORE APPROACHING MACHINE.**

### DRIVE CHAIN ADJUSTMENTS

The mill to mixer auger/supplement hopper drive chain and the discharge auger drive chain are tensioned with a wood block idler. (See Figure 144 and Figure 145.) Adjust the chain tension to 1/2 inch total deflection by positioning the wood block idler.

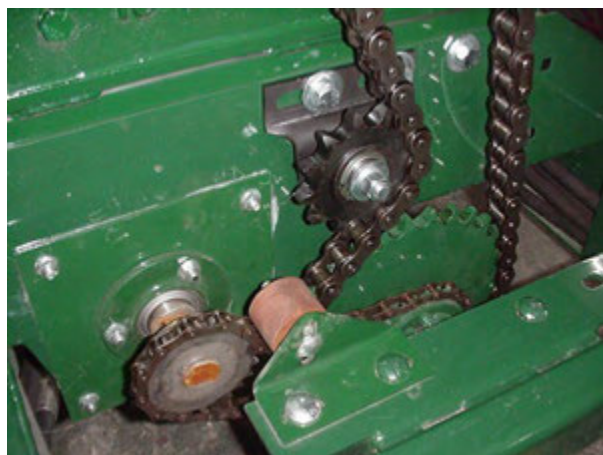

Figure 144 - Mill To Mixer Auger Drive Chain.



Figure 145 - Discharger Auger Drive Chain.

### MAIN DRIVE CHAIN

Adjust the tension of the main drive chain by loosening the idler roller and bolt, and then sliding the idler sprocket toward the chain. (See Figure 44.) Re-tighten the idler roller bolt and make sure the chain deflection is 1/2 inch total at the longest span.

**NOTE:** Chain should be checked and oiled daily.

### ROLL SPEED DIFFERENTIAL

Your CattleMaxx may be equipped with a belt driven roll speed differential that increases the speed of the eccentric roll. Be certain to maintain proper belt tension with stretch loaded idler (See Figure 144) as the belts will stretch during their break-in period. Improper tensioning or overloading the mill will cause the belts to slip causing premature wear and reduced belt life.

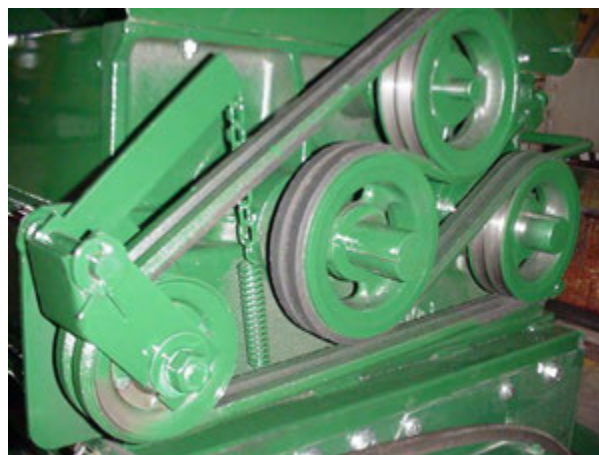

Figure 146 - Drive Chain Adjustment (Shields Removed For Clarity).

### ROLL GAP

The minimum roll gap on the mill must be maintained to ensure a consistent fine particle size. This should be monitored as the rolls wear and also need to be adjusted for any replacement or re-grooved rolls.



**DANGER: DO NOT MAKE ANY ADJUSTMENTS WHILE THE CATTLEMAXX IS IN OPERATION.**

To open the roll gap, loosen the eccentric lock bolts (See Figure 147) with the wrench provided and pull up on the eccentric roll handle. A pointer gage (See Figure 147) on the eccentric roll bearing housing can be used as a reference for wider roll gaps. Each mark on the gage is approximately 0.015 inch of additional roll gap. Always re-tighten the eccentric

lock bolts when processing, otherwise the roll gap will open and feed particle size will increase.

To check the roll gap, remove the 20 inch magnet (See Figure 148) from the hopper throat. Using a feeler gage, check the current roll gap with the eccentric roll handle down on the stops and the eccentric lock bolts snugged down. Be sure to check the roll gap at the front and back of the rolls. Also rotate the rolls to check several different places on the roll diameter, as there may be 0.001 to 0.002 inch difference in the concentricity of the rolls.

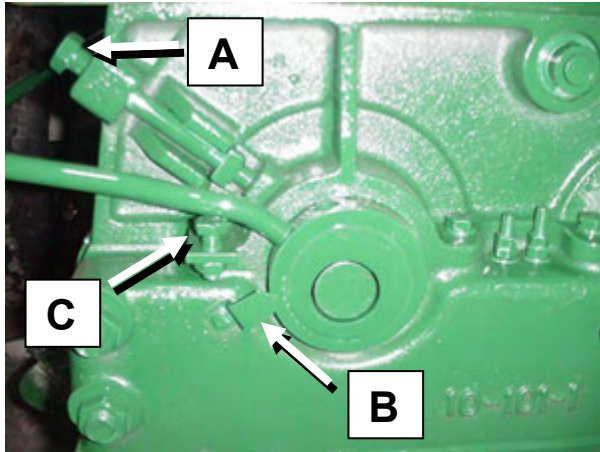

**Figure 147 - Roller mill Housing Eccentric Bearing. A - Eccentric Lock Bolts, B - Pointer Gauge, C - Stop Bolts.**



**Figure 148 - Removing Magnet To Check Roll Spacing.**

To change the minimum roll gap, loosen the eccentric lock bolts and pull the eccentric roll handle up and out of the way. Loosen the jam nuts on the 1/2 inch stop bolts (See Figure 149) and turn both the front and rear stop bolts evenly, up for a wider roll gap and down for a smaller roll gap. Lower the eccentric roll handle to the stop bolts and re-tighten the eccentric lock bolts. Re-check the roll gap and repeat as necessary until the desired roll

gap is attained. Be sure to re-tighten the jam nuts on the stop bolts when finished.

**NOTE:** Rolls must not be set closer than 0.008 inch gap. Never adjust the minimum roll gap setting with the tractor PTO engaged. The roller mill rolls will be severely damaged if they ever touch while the PTO is engaged.

### **ROLL PARALLELISM**

If the roll gap is different from front to back on the rolls, the rolls are out of parallel and need to be adjusted. This can occur from the eccentric roll handle getting bent or twisted, or uneven roll wear from not keeping the hopper full across the whole width while processing. To adjust roll parallelism, reset one stop bolt up or down. Be certain to push down on each corner of the eccentric roll handle when tightening the eccentric lock bolts to ensure both sides of the handle are in contact with the stops. The eccentric roll handle may have to be twisted to accommodate an excessive stop bolt adjustment.

### **ROLL SCRAPERS**

Roll scraper clearance needs to be monitored as the rolls wear and should be adjusted after changes in a minimum roll gap setting or when replacing rolls. The main drive roll scraper should be set at 0.006 inch clearance and the eccentric roll should be set at 0.050 inch clearance. Be sure the minimum roll gap is set and the rolls locked in place before setting the scrapers.

To adjust the roll scrapers, loosen the jam nuts on the scraper adjustment bolts (See Figure 149). Turn the adjustment nut clockwise to bring the scraper closer to the roll. Turn the roll by hand while adjusting the scraper. When the scraper contacts the roll, back the adjusting nut off slightly until no scraper to roll contact can be heard. On the opposite side of the mill (front to back) turn the adjustment nut on the same scraper until the scraper contacts the roll. Back the adjustment nut off slightly until no scraper to roll contact can be heard. Recheck the side of the mill you started on and repeat the procedure if further adjustment is needed.





Figure 149 - Roll Scraper Adjustment Bolts

Repeat this procedure for the opposite roll. To check for actual scraper clearance, remove the side panels of the mill and measure the clearance with a feeler gage.

**NOTE:** Do not adjust rolls scrapers with the tractor PTO engaged. Roll to scraper contact with the PTO engaged will severely damage the rolls and scrapers.

#### **MANUAL UNLOADING AUGER SWING CRANK ADJUSTMENT FOR SPROCKET ENGAGEMENT**

Adjust by loosening the three bolts shown (See Figure 150) and moving the assembly up to engage the teeth of the sprocket with the disk.



Figure 150 - Manual Unloading Auger Swing Crank Adjustment

#### **MANUAL UNLOADING AUGER SWING BRAKE ADJUSTMENT**

Tighten or loosen nut and bolt, to maintain tension to hold unloading auger (See Figure 151).



Figure 151 – Manual Brake Adjustment

#### **MANUAL LIFT ADJUSTMENT**

If the chain becomes loose, loosen bolts on the crank shaft and position chain to the proper tension (See Figure 152).

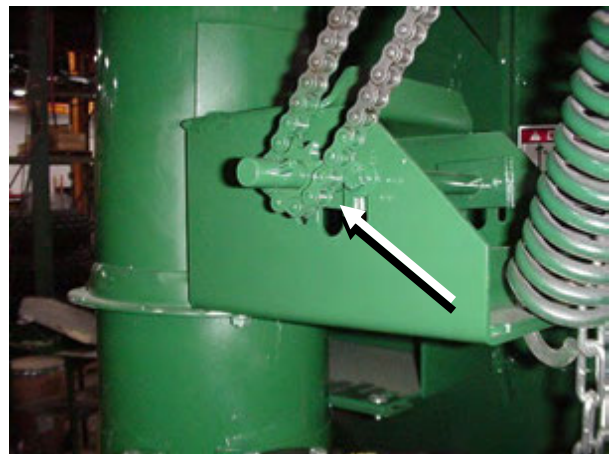

Figure 152 - Crank Shaft Chain Adjustment Bolts

#### **HYDRAULIC SWING DRIVE ADJUSTMENT**

If any problem is encountered with the hydraulic swing adjustment drive, adjust and/or check as follows: (See Figure 153.)



**Figure 153 - Hydraulic Swing Adjustment (Shields Removed For Clarity).**

1. Loosen the four hydraulic motor bolts and remove the #60 chain.
2. Wrap the #60 chain completely around the 55 tooth sprocket. Inspect the chain, matching the sprocket teeth in the two areas where the sprocket is split. If the rollers on the chain do not seat into the root of the sprocket teeth, loosen the 10 bolts that hold the sprocket to the upper ring; holding the chain across the split areas, re-tighten the bolts so the chain properly seats into the sprocket teeth.
3. Re-tighten the hydraulic motor bolts then check the alignment of the sprocket. If the sprocket is not aligned properly, loosen the set screws on the 10 tooth sprocket and re-align.
4. Reinstall #60 chain and tension. Reinstall Shield.
5. Adjust spring tension to be sure auger will slip if it hits something solid (See Figure 153). If it doesn't slip, damage to discharge could occur.

### **HYDRAULIC SWING SPEED ADJUSTMENT**

The speed of the discharge auger swing can be controlled by adjusting the flow control valves at the swing motor (See Figure 154). These valves are preset at the factory to be open 1.5 turns. When changing the swing speed be sure to adjust both valves equally. Different valve settings will cause excessive back pressure at the motor that may cause shaft seal failure.

To adjust the flow control valves, loosen the jam nut behind the knob. Turn the knob clockwise for lower flow or counter-clockwise for higher flow. Mark the knobs so they can both be adjusted equally. Tighten the jam nut after adjustments are finished

and check discharge auger swing for proper operation.



**Figure 154 - Hydraulic Swing Flow Control Valves.**

### **LIFT ASSIST SPRING ADJUSTMENT**

The lift assist spring may lose tension after excessive usage. It is important to keep proper tension on the spring, this spring helps ease raising and lowering the discharge auger. Adjust the spring tension by removing bolt in hole and moving to the hole shown (See Figure 155). Additional tension needed with discharge extensions.



**Figure 155 - Lift Assist Spring Adjustment Bolts**

### **Hydraulic Discharge Chains' Adjustment (6105H Models Only)**

Hydraulic Discharge models contain three 9.6 CID hydraulic motors (See Figure 156, Figure 157, and Figure 158).

The upper discharge motor is directly coupled to the auger shaft using four set screws (See Figure 156).

The middle discharge uses a #60 chain and sprockets. The tension is maintained using a positive stop style tensioner. Loosen jam nut followed by tightening or loosening bolt for proper chain tension (See Figure 157).

Lower discharge motor uses a #40 chain, sprockets, and wood block idler. Position wood

block idler against chain to adjust to proper tension. Periodically wood block idler will need to be loosened and clocked differently to maintain the proper contact with chain (See Figure 158).

Middle and lower discharge motor chains should have no more than ½" of deflection at longest span. Check chain tightness on regular basis to eliminate the risk of premature chain/sprocket wear and the possibility of "jumping teeth" during use.

**NOTE:** Do NOT over tighten chains on middle and lower discharge motors, doing so will cause premature failure in motor seals/bearings.



Figure 156 - Upper Discharge Motor (Unload)



Figure 157 - Middle Discharge Motor (Vertical)

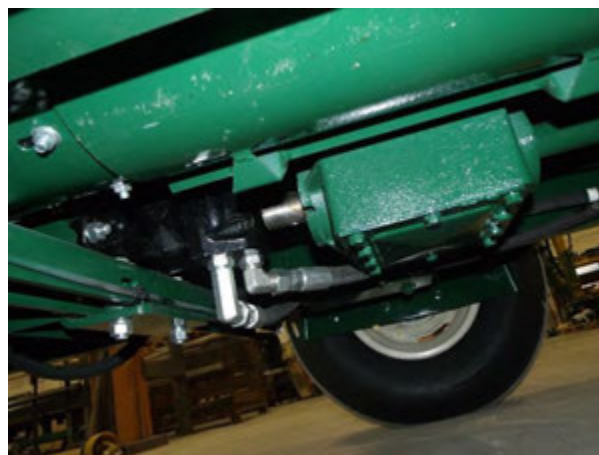

Figure 158 - Lower Discharge Motor (First Section)

### POSITIONING THE UNLOADING AUGER TO OPPOSITE SIDE OF MACHINE

To change to the opposite side, lift the unloading auger until it is straight up and comes down the opposite side. Rotate the hood downward. Move the saddle to the opposite side of the mixing tank.

An unloading auger swivel stop (See Figure 159) prevents the unloading auger from contacting the mixing tank when moved 180 degrees from the storage position. Relocate the swivel stop so it contacts the bracket before unloading auger contacts the tank.

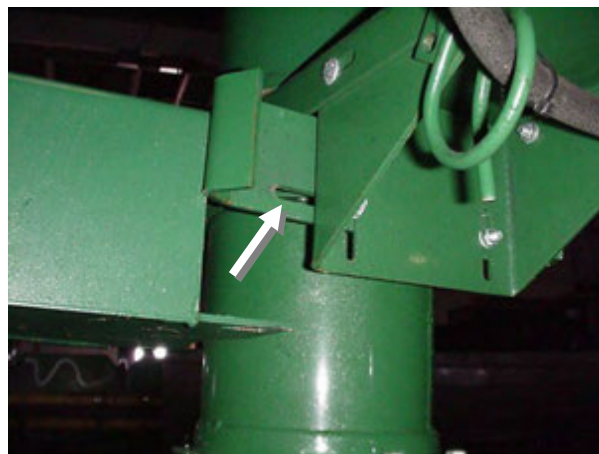

Figure 159 - Swivel Stop.

### SWIVEL STOP ADJUSTMENT

Adjust the bracket so it makes contact before the unloading auger contacts the tank when moved 180 degrees from the storage position (See Figure 159).

### OPEN AND CLOSED HYDRAULICS

As the standard, this machine is equipped for tractor "Open Center" hydraulic operation.

If the operation of the auger feeder is to be with a tractor that is equipped with a “Closed Center” hydraulic system, revision to the plumbing at the control valve bypass should be made. Refer to the tractor operator’s manual or consult your local tractor dealer to make sure which system the tractor is equipped with. (See Figure 160)

To convert to “Closed Center” hydraulic system, revise as shown. (See Figure 160) **When revised for “Closed Center” operation, do not use on a tractor with “Open Center”.**

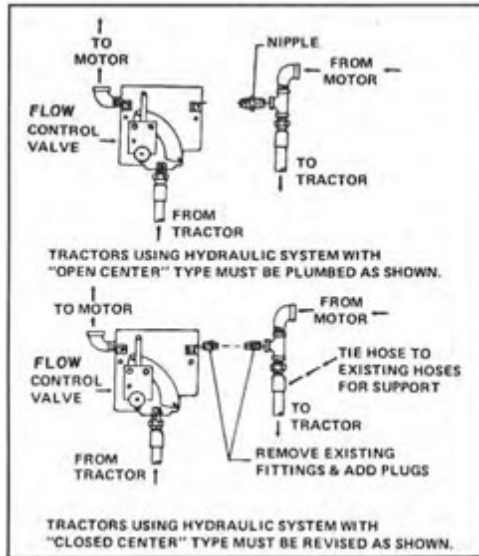

Figure 160 - Open And Closed Hydraulic Systems.

### CONVERTING TO CLOSED CENTER HYDRAULICS

To convert the hydraulic system to “Closed Center” perform the following: (See Figure 160)

7. At the control valve upper right corner, disconnect the hydraulic hose from the motor.
8. Disconnect the hydraulic hose to tractor from the tee and elbow then remove the nipple.
9. Install the plugs in the valve and tee where the nipple was removed.
10. Connect the hydraulic hoses to the tee and elbow.
11. Tie the hoses together for additional support.

### WHEEL BEARINGS

Raise the frame and make sure it is blocked securely so the wheels may turn freely (make sure the opposite wheel is also blocked securely). To tighten the wheel bearing, remove the hub cap. Remove the cotter pin from the slotted nut and tighten the slotted nut while rotating the wheel. Loosen or back-off the nut to the nearest slot, insert and spread the cotter pin.

There should be a slight drag on the bearing following the adjustment. Replace the hub cap. (Figure 161)



Figure 161 - Wheel Bearing Adjustment.

## LUBRICATION



**CAUTION: BEFORE LUBRICATING THE MACHINE, MAKE SURE THE ENGINE IS SHUT OFF, PLACE THE KEY IN YOUR POCKET AND DISCONNECT THE IMPLEMENT INPUT DRIVELINE**

The CattleMaxx is designed to require a minimum amount of lubrication. The points that are to be lubricated should be serviced regularly at the specified intervals listed in this manual.

Keep your supply of lubricating oil and grease in clean containers and covered to protect them from dust and dirt.

Keep the lubricating gun nozzle clean and free from dirt at all times. Wipe all of the dirt from the grease fittings before lubricating them.

### PTO DRIVELINE

Grease the bearing crosses, telescoping, and plastic shield rotation every 20 hours. The zerk is located on the sliding shaft. (See Figure 162 and Figure 163)



Figure 162 - PTO Driveline (Shield Removed For Clarity).



Figure 163 - Plastic Shaft Bearings (See Arrow).

### GRAIN CONTROL GATE

Grease the pivot points and slide on the grain control gate once a year or every 100 hours of operation (See Figure 164).

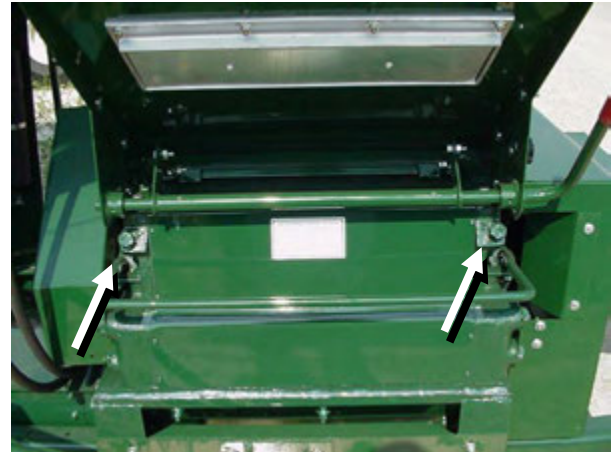

Figure 164 - Grain Control Gate Lubrication (2 Zerks and Slide Guides).

### ROLL BEARINGS

The roller mill roll shaft bearings are a sealed bearing and require no additional lubrication. Monitor the condition of these bearings and replace if overheating of the shaft or roller mill housing occur. New bearings are supplied with replacement rolls.

### ECCENTRIC BEARING HOUSINGS

The bearing housings on the eccentric roll shaft are greased at the factory and should not require additional lubrication under normal operating conditions. These housings should be cleaned and re-lubricated if the eccentric roll becomes hard to move or whenever the mill is torn down for service (See Figure 165).

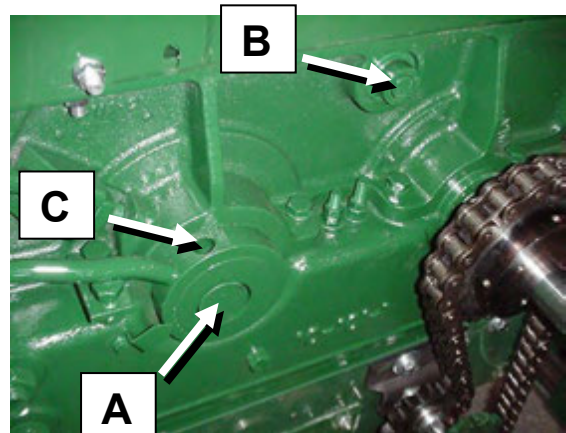

Figure 165 - A - Roller mill Bearings, B - Agitator Shaft Bearings, C - Eccentric Housing

### **AGITATOR SHAFT BEARINGS**

The agitator shaft bearings are a sealed bearing and require no additional lubrication. Monitor the condition of these bearings and replace if overheating of the shaft or rollermill housing occur.

### **ROLLERMILL BELT DRIVE**

Be certain to maintain the proper belt tension on the rollermill eccentric drive, as belts will stretch during their break in period. Keep the spring-loaded idler properly tensioned and lubricated to pivot freely (See Figure 166). Improper tensioning or overloading will cause the belts to slip and causing premature wear and reduced belt life.

The idler pulley bearings on the rollermill belt drive are a sealed bearing and require no additional lubrication. Monitor the condition of these bearings and replace as necessary.



**Figure 166 – Rollermill Belt Drive**

### **HOPPER MAGNETS**

Periodically check the hopper magnets for tramp metal and debris and clean as necessary. Open the hopper lid to inspect the hopper plate magnets. Always clean the plate magnets with the throat magnet installed. Remove the throat magnet for cleaning and inspection. Be sure not to let any material from the magnets fall into the rollermill (See Figure 167).

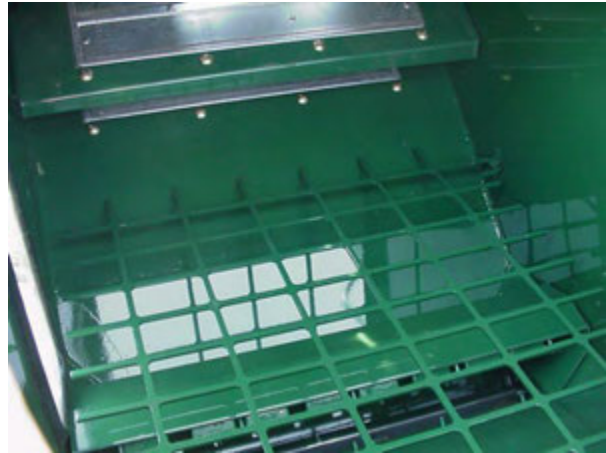

**Figure 167 - Cleaning Magnets**

### **CHAINS**

Chains should be lubricated at frequent intervals. Apply a light engine oil to the chain. Oil the chain on the inside located in the upper side of lower the strand. (See Figure 168)

The chains should also be cleaned regularly. Remove the chains and dip or soak them in kerosene. Once the chains have been cleaned, dry and oil them thoroughly.

#### **Oil Roller Chain on Upper Side of Lower Strand**

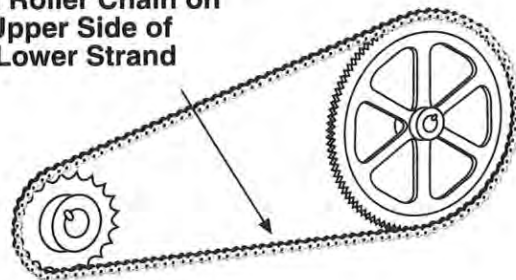

**Figure 168 - Oiling Roller Chains.**

The split end of the chain clip must face the direction opposite of the chain travel. Make sure the clip is properly seated in the groove on the ends of the pin. (See Figure 169)

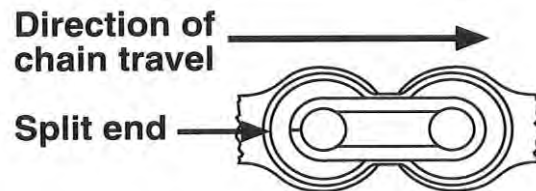

**Figure 169 - Chain Spring Clip.**

**GEARBOX**

Make sure to check the oil level on the gearbox at the base of the mixing tank every 6 months by removing the check plug at the front of the gearbox. Add SAE 90 weight gear oil if necessary and until oil runs out of the check hole. (See Figure 170)

**IMPORTANT:** Do not overfill.



Figure 170 - Gearbox Lubrication.

**LOWER VERTICAL MIXING AUGER**

Refill the grease seal at the bottom of the vertical mixing auger every six months with SAE multi-purpose type grease. Access to this fitting can be gained through the clean-out door in the mixing tank cone, below the large bottom flight of the mixing auger. (See Figure 171)

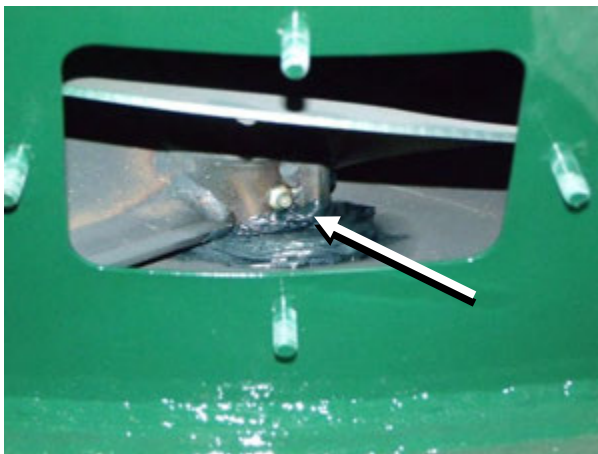

Figure 171 - Clean-Out Door in Mixing Tank Cone And Grease Zerk For Seal At Bottom Of Vertical Mixing Auger.

**UPPER VERTICAL MIXING AUGER**

Grease the upper vertical mixing auger bearing weekly or every 10 hours of operation with SAE multi-purpose type grease. Access to this bearing can be gained through the top of the mixing tank. (See Figure 172)



Figure 172 - Upper Vertical Mixing Auger Bearing.

**TANK VENT**

The mixing tank is vented through the left ladder rail (right-hand when facing ladder). Periodically blow air through this tube and check the opening in the tank to ensure that the vent is clear of dust and debris. A clogged tank vent may cause the spring loaded tank lid to open or windows to pop out from the side of the CattleMaxx (See Figure 173).



Figure 173 - Left Ladder Vent (Right-Hand When Facing Ladder).

**UNLOADING AUGER CLUTCH**

Apply SAE multi-purpose grease to the shaft and groove in the under sliding (driven) unloading auger clutch half. This should be done periodically to ensure proper lubrication. (See Figure 174)

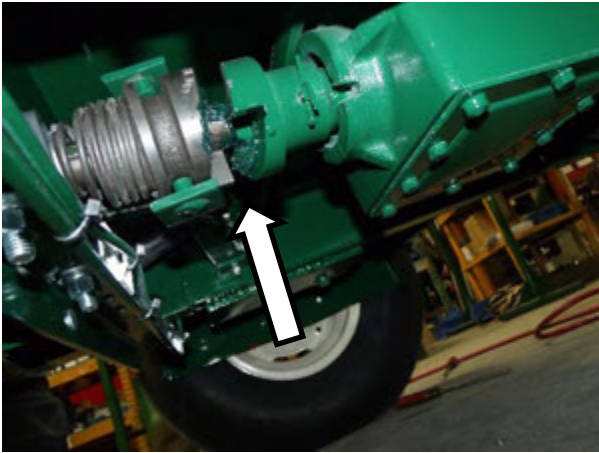

Figure 174 - Unloading Clutch Operation.

**SWIVEL CLAMP**

Grease the lower swivel clamp every week to ensure the swivel clamp is properly lubricated. (See Figure 175)



Figure 175 - Swivel Clamp Area, Discharge Auger (Shield Removed For Clarity).

**ELBOW**

Periodically grease the gear sets at each unloading auger transfer point using SAE multi-purpose grease every 20 hours (See Figure 176, and Figure 177).



Figure 176 - Discharge Auger Bevel Gears, Inner Elbow (Shields Removed For Clarity).

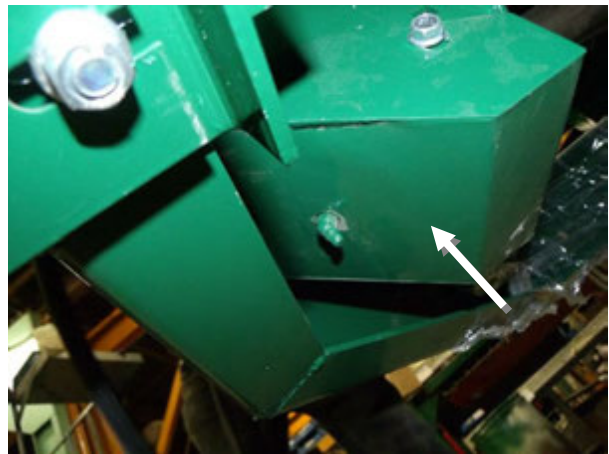

Figure 177 - Discharge Auger Bevel Gears, Outer Elbow Shield.

**RING AND WORM GEAR (MECHANICAL)**

Grease at two locations on large ring gear for unloading auger lift pivot (See Figure 178). On units with mechanical back auger, apply grease at ring gear and worm gear periodically. Use SAE multi-purpose type grease.



Figure 178 - Ring And Worm Gear Bearings



**WHEELS**

Remove, clean, and repack the wheel bearings once a year or every 100 hours of operation using SAE multi-purpose type grease. (See Figure 179)



**Figure 179 - Wheel Bearing Lubrication.**

# SERVICE

## TORQUE SPECIFICATIONS



**CAUTION: DISENGAGE ALL DRIVES AND MAKE SURE THE TRACTOR ENGINE IS SHUT OFF. PLACE THE KEY IN YOUR POCKET AND DISCONNECT THE PTO DRIVELINE PRIOR TO SERVICING THE GRINDER MIXER.**

When performing service on the CattleMaxx and its components, take time to use and comply with the torque specification guide. (Refer to Table 10)

Size	Clamp Load	Plain GR 5	Plated GR 5
1/4 – 20 (.250)	2,025	8 ft. lbs.	76 in. lbs.
5/16 – 18 (.3125)	3,338	17 ft. lbs	13 ft. lbs.
3/8 – 16 (.375)	4,950	31 ft. lbs.	23 ft. lbs.
7/16 – 14 (.4375)	6,788	50 ft. lbs.	37 ft. lbs.
1/2 – 13 (.500)	9,075	76 ft. lbs.	57 ft. lbs.
9/16 – 12 (.5625)	11,625	109 ft. lbs.	82 ft. lbs.
5/8 – 11 (.625)	14,400	150 ft. lbs.	112 ft. lbs.
3/4 - 10 (.750)	21,300	266 ft. lbs.	200 ft. lbs.
7/8 – 9 (.875)	29,475	430 ft. lbs.	322 ft. lbs.
1 – 8 (1.00)	38,625	644 ft. lbs.	483 ft. lbs.
1-1/8 – 7 (1.125)	42,375	794 ft. lbs.	596 ft. lbs.

**Table 10 - Torque Specification Guide For Grade 5 Bolts.**

## SHEAR BOLTS



**WARNING: SHEAR BOLTS MAKE A LOUD NOISE WHEN SHEARED. IMMEDIATELY SHUT THE TRACTOR IGNITION OFF AND DETERMINE THE CAUSE OF SHEARING.**

Shear bolts will make a loud noise when they shear. This is your warning to turn off the tractor ignition immediately and determine the cause of the shear.

Shear bolt locations on the CattleMaxx are:

- The PTO driveline shear clutch
- The mixer drive #80 sprocket on the lower drive shaft
- The mill to mixer and supplement auger drive #40 sprocket on the lower driveshaft

- Discharge auger drive clutch on the gearbox output shaft.

Drive	Location	Bolt/Pin	Part No.
PTO Driveline	PTO Shear Clutch	Bolt, M10-1.5 x 60 (metric)	407760
Mixer Drive	#80 Sprocket, Lower Driveshaft	Bolt, 1/4-20 x 1-1/2 Grade 5	047000
Mill To Mixer Auger	#40 Sprocket, Lower Driveshaft	Bolt, 1/4-20 x 1 Grade 5	042960
Discharge Auger	Rear Drive Clutch	Clevis Pin, 3/8 X 2-3/8	041540

**Table 11 - Replacement Shear Bolts**

If these designed shear points are not the problem than most likely a sheared keyway in an individual components is the problem. Clear the obstruction that caused the overloading and repair/replace components as necessary.

When replacing sheared bolts, always tighten them securely using lock nuts. The shear bolts must be the correct harness to ensure safety. (See Figure 180)

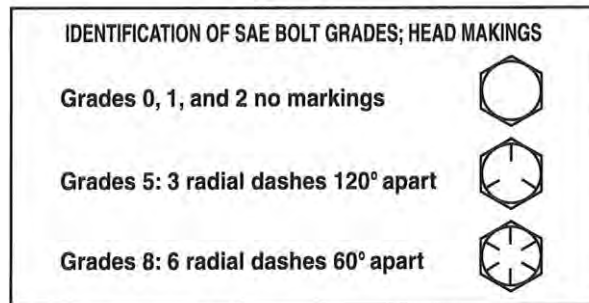

**Figure 180 - SAE Bolt Identification.**

## SPROCKET AND CHAIN ALIGNMENT

Make sure the sprockets are in line with each other. (See Figure 181) If the sprockets are not aligned a sideways pull will develop and will concentrate the load on sides of the sprocket teeth and on the side of the chain. (See Figure 182) This faulty alignment will result on excessive wear on both the chain and sprockets.



Figure 181 – Sprocket And Chain Alignment

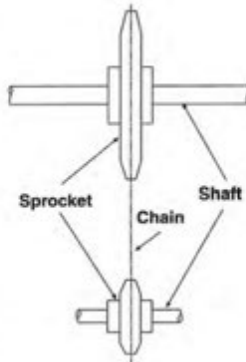

Figure 182 - Sprocket Alignment.

### REPLACEMENT ROLLS

Worn rolls can be replaced with either new rolls or re-grooved rolls. A deposit must be made on the purchase of re-grooved rolls. This deposit is refundable upon the return of the worn rolls and inspection by Art's-Way deeming that the returned rolls can be re-grooved. Rejection of used rolls will be for such things as excessive wear (minimum roll diameter) or cracked/broken rolls.

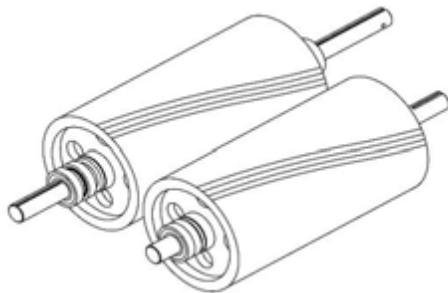

Figure 183 - Replacement Rolls Supplied with Shaft and Bearings on 20 Inch Rolls Only

### ROLL REPLACEMENT

When using roll combinations with different grooves (sharp to sharp or flat to flat) the coarser grooved roll is the drive roll. When combining sharp and flat rolls with same number of grooves, the drive roll is the sharp roll. Ensure rolls and shafts are the proper combination before installing.

Replacement 20 inch rolls are supplied with shafts and bearings. To replace the rolls, perform the following:

1. Remove the PTO, front and rear guards, rear belts drive, and front drive chain.
2. If the CattleMaxx is equipped with an auger feeder, remove the pivot pin at the top of the hopper and support the auger feeder off to the side.
3. Remove the 4 bolts on the front and rear roller mill castings that hold the top and bottom halves of the mill together. Lift the top half off in one assembly. Pick up and save the two brass plugs that were in the upper castings beneath the eccentric tightener bolts.
4. Lift out the rolls and remove any pulleys, sprockets, and bearing housings. For 20 inch rolls leave the old shaft and bearings with the worn rolls. The roll handle is a press fit into the bearing housings. Use care when removing the bearing housings as they can be easily damaged by hammer blows.
5. Thoroughly clean the machined surfaces of the top and bottom castings. Press the bearing housing onto the new roll assemblies. Replace the adjusting handle on the eccentric roll.
6. Grease the outside of the bearing housings and place the roll assemblies in the bottom half of the mill. The dowel spacers in the bottom casting will position the rolls front to back.
7. Replace the top half of the mill and securely bolt into place. Check that the rolls will turn without interference and the eccentric handle will move freely.
8. Replace all pulleys, sprockets, belts, and chains as well as the two brass plugs below the eccentric lock bolts. Replace the front and rear guards.
9. Replace the auger feeder to the hopper lid if applicable.
10. Set the roll gap as described in the "adjustment" section of this manual. Set the rolls for proper minimum gap and parallelism.
11. Set the roll scrapers for the new rolls as described in the "Adjustments" section of this manual.

## TROUBLESHOOTING GUIDE

The majority of difficulties are caused by improper adjustments. When you encounter trouble, perform a systematic check of all possible adjustments using the chart that follows. If difficulties cannot be corrected by making the adjustments that follow, consult your local Art's-Way authorized dealer for further assistance.

TROUBLE	POSSIBLE CAUSE	POSSIBLE REMEDY
PTO driveline is hard to telescope and hard to connect	Shafts are twisted due to overloading of the mill	Replace PTO driveline if necessary. Check for proper shear bolt in PTO shear clutch.
	Lack of grease on the sliding halves	Lubricate as necessary
	Tractor drawbar improperly adjusted.	Adjust tractor drawbar.
Excessive noise when turning the mixer while it is in operation	Turning the mixer too sharply	Avoid sharp turns
	Lack of grease on sliding halves	Lubricate as necessary
	Tractor drawbar improperly adjusted	Adjust tractor drawbar.
Tractor engine RPM falls below the rated PTO speed while grinding	Overloading mill	Close grain control gate.
	Drive belts too loose	Tighten belts
	Drive belts wore	Replace drive belts.
	Material packing on rolls	Adjust scrapers Open roll gap Install roll speed differential.
Shear pins break	Foreign objects and debris (nuts, bolts, etc.) in mill, mixers, or augers	Remove foreign objects.
	Grain in mill on start-up	Open eccentric roll to let grain flow through. Clean material from rolls.
	High RPM starts and stops	Lower RPM PTO engage and disengage. Gradually speed up and slow down.
Mill vibrates excessively while in operation	PTO driveline is not properly aligned	Front of CattleMaxx main shield must be parallel to tractor axle
	PTO driveline is bent	Replace the PTO driveline
	Overloading mill (low rumbling)	Close down grain control gate/open roll gap.
	Tractor drawbar is not adjusted properly	Adjust the tractor drawbar.
Rollermill loses capacity	Grain gate open too far	Close grain control gate
	Material packing on rolls – high moisture material	Adjust roll scrapers
	Rolls are worn, gouged, and smooth	Replace with new or regrooved rolls.

TROUBLE	POSSIBLE CAUSE	POSSIBLE REMEDY
Rolls making load or unusual noises	Rolls are touching	Check roll gap and adjust as needed.
	Roll scrapers touching rolls	Adjust roll scrapers
	Overloading mill (low rumbling)	Close down control gate/open roll gap.
Rollermill suddenly chokes	Material packed on the rolls – high moisture material	Clean rolls. Adjust roll scrapers Install roll speed differential.
Mill will not maintain roll gap setting	Eccentric lock bolts loose	Tighten lock bolts
	Brass shear plug worn or missing	Inspect and/or replace shear plug. Clean knurled surface of eccentric bearing housing.
Drive belt squeals when the mill is engaged	PTO drive may not be fast enough	Speed up tractor to 540 RPM
	Drive belts are too loose	Tighten the drive belts
	Drive belts worn	Replace drive belts
	Material packed on rolls	Open roll gap Clean rolls Adjust roll scrapers
	Overloading mill	Close down grain control gate
Drive belts show excessive wear	Belts are out of alignment	Align the pulleys
	Belts are slipping	Tighten belts.
Whole grain kernels in feed	Large roll gap	Adjust belts.
	Rolls out of parallel	Check roll parallelism and adjust as needed.
	Eccentric roll moving/increased roll gap	Tighten eccentric lock bolts Check and replace brass shear plug as needed Clean knurled surface of eccentric bearing housing.
	Rolls worn	Inspect rolls and replace as needed.
Material bridges in the tank	High moisture content material	Process high moisture material last or run straight through tank.
Mill runs but unloading auger and mixing auger do not run	Pin(s) sheared in drive	Correct cause of sheared pin and replace.
Unloading auger runs but feed is not unloading	Mixer tank door closed	Open door
	Mixer auger not turning	Check for sheared key in lower gearbox.
Auger feeder does not engage	Hydraulic flow control valve disengaged	Engage flow control valve
	Selector valve position	Change position of selector valve (OUT for auger feeder).

## ATTACHMENTS

### ELECTRONIC SCALE ATTACHMENT

A solid state electronic scale attachment, digital type, is available for your grinder mixer. The scale attachment consists of weigh bar sensors mounted on the CattleMaxx axle spindles and hitch. They are electronically connected to the indicator bars. The indicator alarm system is available with the electronic scale attachment. Scale accuracies of one percent or less are obtained. Complete installation and operating instructions are included with the attachment.

### ADJUSTABLE SCALE ARM ATTACHMENT

The optional scale arm allows the electronic scale to be positioned along a 180° arc off the side of the grinder. (See Figure 184.) Tension on the pivot point spring can be increased or decreased by tightening or loosening the nut. Periodic grease needs to be applied to the zerk on the pivot point.



Figure 184 - Adjustable Scale Arm Attachment

### DISCHARGE UNLOADING AUGER EXTENSIONS

3 and 6 foot folding and 3 and 6 foot bolt-on discharge auger extensions are available (See Figure 185). For unloading height obtainable with various extensions added to the unloading auger system, (refer to Table 9). For unloading auger instructions, refer to OPERATION OF GRINDER MIXER section.

Additional spring tension needed on lift assist. Refer to LIFT ASSIST SPRING ADJUSTMENT Section (pg. 80).



Figure 185 - Folding Auger Extensions.

# SPECIFICATIONS

<b>TANK AND</b>							<b>6105 CattleMaxx</b>
Capacity of						105 bushel (129 cu. ft.)	
Height (variable)						106 inches	
Width with						95 inches	
Overall length						170 inches	
Weight						3,560 lbs.	
<b>Discharge Auger</b>							
Auger length						125 inches	
Auger diameter						7 inches	
Auger tube						8 inches	
10 inch main						16 ft. 7 inches	
Horizontal						324 degrees	
Vertical						Infinite	
<b>Auger Feeder</b>							
Auger length						117 inches	
Auger diameter						7 inches	
Auger hopper						23 inches	
Height of						17.5 inches	
Height of						42 inches	
<b>Mixing Auger</b>							
Auger width						12 inches	
Mixing base						24 inches	
<b>Supplement</b>							
Auger diameter						7 inches	
Hopper size						21 inches X 24 inches	
Height from						34 inches	
<b>Rollermill (Rolls)</b>							
Width of Mill						20 inches	
Roll diameter						10 inches	
Operating						540 RPM	
Operating						540 RPM	
Roll grooves						5, 7, and 10	
Type of drive						PTO direct	
Power required						50 hp.	

**NEW LOGO HERE**

## **ART'S-WAY MANUFACTURING CO., INC. TECHNICAL MANUALS**

Manuals are available from your local dealer or Art's-Way Manufacturing Co., Inc. for the operation, service, and repair of your machine. For prompt convenient service, contact your local dealer for assistance in obtaining the manuals for your machine.

Your local dealer can expedite your order for operator manuals, illustrated parts catalogs, service manuals, and maintenance records.

Always give the Machine Name, Model, and Serial Number so your local dealer can provide the correct manuals for your machine.

Art's-Way Manufacturing Co., Inc. reserves the right to make improvements in design or changes in specifications at any time without incurring any obligation to install them on units previously sold.

Except as expressly authorized, no part of this manual may be reproduced, copied, transmitted, disseminated, downloaded or stored in any storage medium, for any purpose without the express prior written consent of Art's-Way Manufacturing Co., Inc.

**ART'S-WAY MANUFACTURING CO., INC.  
HWY 9 WEST - PO Box 288  
Armstrong, IA. 50514 U.S.A**

© Copyright 2013  
ART'S-WAY MANUFACTURING CO., INC.  
All Rights Reserved



Produced And Published In The U.S.A. By



**CPS DYNAMICS, LLC**

PO Box 9007  
Wichita, KS 67205  
[www.cpsdynamics.com](http://www.cpsdynamics.com)

**NEW ARTS WAY LOGO HERE**

**Art's-Way Manufacturing Co., Inc.  
Hwy 9 West – PO Box 288  
Armstrong, IA. 50515 U.S.A**