

**Operator's Manual &  
Illustrated Parts List**

**Model X350  
Manure Spreader**



Art's Way Manufacturing

725735

Issued March 2024



This symbol means ATTENTION! BECOME ALERT! YOUR SAFETY IS INVOLVED. The message that follows the symbol contains important information about your safety. Carefully read the message. Make sure you fully understand the causes of possible injury or death.

IF THIS MACHINE IS USED BY AN EMPLOYEE, IS LOANED, OR IS RENTED, MAKE SURE THAT THE OPERATOR UNDERSTANDS THE TWO INSTRUCTIONS BELOW.

**BEFORE THE OPERATOR STARTS THE ENGINE:**

GIVE INSTRUCTIONS TO THE OPERATOR ON SAFE AND CORRECT USE OF THE MACHINE.

MAKE SURE THE OPERATOR READS AND UNDERSTANDS THE OPERATOR'S MANUAL FOR THIS MACHINE.

 **WARNING**

IMPROPER OPERATION OF THIS MACHINE CAN CAUSE INJURY OR DEATH.

**BEFORE STARTING THE ENGINE, DO THE FOLLOWING:**

1. READ THE OPERATOR'S MANUAL.
2. READ ALL SAFETY DECALS ON THE MACHINE.
3. CLEAR THE AREA OF OTHER PERSONS.
4. LEARN AND PRACTICE SAFE USE OF MACHINE CONTROLS IN A SAFE AND CLEAR AREA BEFORE YOU OPERATE THIS MACHINE ON A JOB SITE.

It is your responsibility to observe pertinent laws and regulations and to follow manufacturer's instructions on machine operation and maintenance.

See your Authorized Art's Way Manufacturing dealer or Art's Way Manufacturing for additional operator's manuals, illustrated parts catalogs, and service manuals.

---

## **TO THE OWNER**

Congratulations on the purchase of your new Art's Way Manure Spreader. You have selected a top quality machine that is designed and built with pride to ensure you have many years of efficient and reliable service.

Many people have worked on the design, production, and delivery of this Manure Spreader. The information in this manual is based on the knowledge, study, and experience through years of specializing in the manufacturing of farm machinery. This manual is designed to provide you with important information regarding safety, maintenance, and machine operation so you can and will get the best possible performance from your Manure Spreader.

Even if you are an experienced operator of this or similar equipment, we ask that you read this manual before operating this Manure Spreader. The way you operate, adjust, and maintain this unit will have much to do with its successful performance. Any further questions you may have about this product of Art's Way equipment should be directed to your local Art's Way dealer or to Art's Way Manufacturing Armstrong, Iowa, 50514, (712) 208-8467.

### **SPECIFICATIONS AND DESIGN ARE SUBJECT TO CHANGE WITHOUT NOTICE**

Art's Way Manufacturing is continually making product improvements. In doing so, we reserve the right to make changes and/or add improvements to our products without obligation for the equipment previously sold.

Modifications to this Manure Spreader may affect the performance, function, and safety of its operation. Therefore, no modifications are to be made without the written permission of Art's Way Manufacturing. Any modification made without the written permission of Art's Way Manufacturing shall void the warranty of this product.

In the interest of continued safe operation of this Manure Spreader, pay particular attention to the safety alert symbol(s) throughout this manual.

### **Art's Way Manufacturing STATEMENT OF PRODUCT LIABILITY**

Art's Way Manufacturing recognizes its responsibility to provide customers with a safe and efficient product. Art's Way Manufacturing, attempts to design and manufacture its products in accordance with all accepted engineering practices effective at the date of design. This statement should not be interpreted to mean that our products will protect against the user's own carelessness or failure to follow common safety practices nor will Art's Way Manufacturing, be liable for any such act. In addition, Art's Way Manufacturing, assumes no liability for any altered product or any modified product by users or anyone other than an authorized dealer.

### **IMPORTANT WARRANTY INFORMATION**

The warranty for this Manure Spreader appears on page 6 of this manual. In order to establish proper warranty registration, the Warranty Registration must be completed and returned to the factory. Failure to comply with this requirement will result in invalidating the warranty!

### **LIMITATIONS OF THIS MANUAL**

This manual contains operating instructions for your X350 Manure Spreader only. Any mention of other machinery in this manual other than the X350 Manure Spreader is for reference only. This manual does not replace nor is it to be used for any machinery that may be attached to or used in conjunction with the X350 Manure Spreader.

## PARTS & SERVICE

As the purchaser of your new spreader, it is very important to consider the following factors:

**A. Original Quality**

**B. Availability of Service Parts**

**C. Availability of Adequate Service Facilities**

Art's Way Manufacturing has an excellent dealership network ready to answer any questions you may have about your spreader. Parts for your machine may be ordered through our dealers. When placing a parts order, please have the **model** and **serial number** ready. This will allow the dealer to fill your order as quickly as possible.

For your convenience, we have provided this space for you to record your model number, serial number, and the date of purchase, as well as your dealer's name and address.

**VAI**

**ART'S WAY**

**SERIAL NUMBER**

**MODEL**

Barcode

## TABLE OF CONTENTS

TO THE OWNER	1
SPECIFICATIONS AND DESIGN ARE SUBJECT TO CHANGE WITHOUT NOTICE	1
Art's Way Manufacturing STATEMENT OF PRODUCT LIABILITY	1
IMPORTANT WARRANTY INFORMATION	1
LIMITATIONS OF THIS MANUAL	1
<u>PARTS &amp; SERVICE</u>	<u>2</u>
TABLE OF CONTENTS	3-5
<u>SAFETY FIRST</u>	<u>7</u>
NOTICES OF DANGER, WARNING, AND CAUTION	7
<u>Safety Instructions</u>	<u>8</u>
GENERAL	8
BEFORE OPERATING	9
DURING OPERATION	9
MAINTENANCE SAFETY	9
HYDRAULIC SAFETY	10
TRANSPORTATION SAFETY	10
STORAGE SAFETY	10
TIRE SAFETY	11
ASSEMBLY SAFETY	11

<b>TABLE OF CONTENTS</b>	
<b>NAME</b>	<b>PAGE</b>
~~~~~OPERATOR'S INSTRUCTIONS: MANURE SPREADER~~~~~	12
~~~~~ILLUSTRATED PARTS LIST: MANURE SPREADER~~~~~	25
TONGUE TO BOX ASSEMBLY	26
RUNNING GEAR TO BOX ASSEMBLY - SINGLE	28
HUB ASSEMBLY - SINGLE	30
WHEEL ASSEMBLY (USED MILITARY) - SINGLE	32
WHEEL ASSEMBLY (FLOATATION) - SINGLE	33
RUNNING GEAR TO BOX ASSEMBLY - TANDEM	34
HUB ASSEMBLY - TANDEM	36
WHEEL ASSEMBLY (FLOATATION) - TANDEM	38
WHEEL ASSEMBLY (SUPER SINGLE) - TANDEM	39
DRIVELINE ASSEMBLY	40
35R DRIVE SHAFT WITH GUARD (TO BEATERS)	42
SLIP SLEEVE SHAFT ASSY (TO TONGUE)	44
1000 RPM 1-3/8 X 21 SPLINE C-V PTO W/CLUTCH PACK	46
1000 RPM 1-3/4 X 20 SPLINE C-V PTO W/CLUTCH PACK	48
540 RPM 1-3/8 X 6 SPLINE C-V PTO W/CLUTCH PACK	50
MAIN FLOOR ASSEMBLY	52
GEARBOX TO BOX ASSEMBLY	54
GEARBOX ASSEMBLY	56
APRON CHAIN AND DRIVE ASSEMBLY	58
SLOP GATE ASSEMBLY	60
BEATER TO BOX ASSEMBLY	62
BEATERS ASSEMBLY - 1000 RPM	64
GEARBOX ASSEMBLY (H12148) (1000 RPM ONLY)	66
GEARBOX ASSEMBLY (H16180) (540 RPM ONLY)	68
ROCK GUARD ASSEMBLY	70
HYDRAULIC COMPONENT ASSEMBLY	72
GREASE ASSEMBLY	74
LIGHTS ASSEMBLY	76
MANUAL ASSEMBLY	78
FLASHING ASSEMBLY	80
DECAL PLACEMENT	82
UNIFIED HYDRAULICS	84
UNIFIED HYDRAULIC MANIFOLD	86



FOR WARRANTY INFORMATION  
REFER TO THE SEPARATE DOCUMENT  
INCLUDED WITH THIS MANUAL OR GET  
IT ONLINE FROM:

[WWW.ARTSWAY.COM](http://WWW.ARTSWAY.COM)



## SAFETY FIRST

### SAFETY INSTRUCTIONS

“A careful operator is the best insurance against an accident.” Quote from the National Safety Council.

Most accidents can be prevented if the operator:

1. Fully understands how the machine functions.
2. Can anticipate situations which may produce problems.
3. Can make necessary corrections before problems develop.

**THIS SYMBOL MEANS ATTENTION!  
BECOME ALERT!  
YOUR SAFETY IS INVOLVED!**



- Universal Safety Alert Symbol

The American Society of Agricultural Engineers has adopted the Universal Safety Alert Symbol as a way to identify areas of potential danger if the equipment is not operated correctly. Please be alert whenever you see this symbol in the manuals or on your spreader.

Art's Way Manufacturing strives to make our equipment as safe as possible. The Art's Way X350 Manure Spreader conforms to applicable safety standards at the time of manufacturing. A safety conscious equipment operator makes an effective accident-prevention program complete.

Safety features and instructions for the spreader are detailed in the Safety Guidelines section of this Operator's Manual. It is the responsibility of the owner to ensure that all operators read and understand the manual before they are allowed to operate the Spreader. (Occupational Safety and Health Administration (OSHA) regulations 1928.57).

### NOTICES OF DANGER, WARNING, AND CAUTION

Signal Words: Note the use of signal words **DANGER**, **WARNING**, and **CAUTION** on the spreader and in this manual. The appropriate signal word for each has been selected using the following guidelines:

### ⚠ **DANGER**

Indicates a hazardous situation which, if not avoided, will result in death or serious injury.

### ⚠ **WARNING**

Indicates a hazardous situation which, if not avoided, could result in death or serious injury.

### ⚠ **CAUTION**

Indicates a potentially hazardous situation which, if not avoided, could result in minor or moderate injury.

### **NOTICE**

NOTICE is used to address practices not related to physical injury.

### SAFETY INSTRUCTIONS

Safety instructions (or equivalent) signs indicate specific safety-related instructions or procedures.

**Note:** Contains additional information important to a procedure and will be found within the regular text body of this manual.

## SAFETY INSTRUCTIONS

### GENERAL

Most work related accidents are caused by failure to observe basic safety rules or precautions. An accident can often be avoided by recognizing potentially hazardous situations before an accident occurs. As you operate and maintain the Spreader you must be alert to potential hazards. You should also have the necessary training, skills, and tools to perform any assembly procedure.

**Improper operation and/or maintenance of this unit could cause a dangerous situation that results in injury or death.**

**Do not use this unit until you read and understand the information contained in this manual. Do not use this equipment for anything other than its intended purpose.**



Safety precautions and warnings are provided in this manual and on the unit. If these hazard warnings are not heeded, bodily injury or death could occur to you or to other persons.

Art's Way Manufacturing cannot anticipate every possible circumstance that might involve a potential hazard. The warnings in this manual and on the product are, therefore, not all-inclusive. If a method of operation not specifically recommended by us is used, you must satisfy yourself that it is safe for you and for others. You should also ensure that the unit will not be damaged or be made unsafe by the methods that you choose.

The information, specifications, and illustrations in this manual are based on the information that was available at the time this material was written and can change at any time.

### Safety Alert Symbols



death.

This is the safety alert symbol. It is used to alert you to potential personal injury hazards. Obey all safety messages that follow this symbol to avoid possible injury or

This manual contains DANGERS, WARNINGS, CAUTIONS, NOTICES, SAFETY INSTRUCTIONS, and NOTES which must be followed to prevent the possibility of improper service, damage to the equipment, personal injury, or death. The following key words call the readers attention to potential hazards.

Hazards are identified by the "Safety Alert Symbol" and followed by a signal word such as "DANGER", "WARNING", or "CAUTION".

**SAFETY  
INSTRUCTIONS**

**Remember:**  
**"The Best Operator is a Safe Operator"**

**CAUTION**



Read and understand the operator's manual and all the safety decals before operating the spreader. Review all safety instructions with all operators annually.

## BEFORE OPERATING

SAFETY  
INSTRUCTIONS

Do not wear loose fitting clothing as it may catch in moving parts.



Make sure all guards and shields are installed, including the tractor power take-off (PTO) master shield, before starting or operating the spreader.



Be sure that the correct implement driveline parts are used and that they are properly secured.

Lower the lifter wheels when the spreader is not in use.

Install safety chain when attaching the spreader to the tractor.



Clear the area of bystanders, especially children, when making repairs, adjustments, or performing maintenance on the spreader.



Do not allow riders.

Put all tractor and machine controls in “neutral” and disengage the PTO before starting. Follow the starting instructions according to the OEM tractor manual.



Operate the spreader only while seated on the tractor seat.



Make sure the unit is adequately supported with safety blocks or safety stands when changing tires or performing maintenance.

## DURING OPERATION

## CAUTION



**Entanglement Hazard**  
Keep hands, feet, hair, and clothing away from moving parts. Wait for all movement to stop before approaching equipment. Before making adjustments:

1. Shut off the tractor,
2. Set parking brake,
3. Put machine in neutral, and
4. Remove key while making adjustments.



Keep all shields and guards in place and in good working condition.



Keep all bystanders, especially children, away from the spreader while in operation.



Do not allow riders while the spreader is in operation.



Do not attempt to unclog, clean, or adjust the spreader while it is running.



Stay away from overhead power lines. Electrocution can occur even without direct contact.



Keep all hydraulic lines, fittings, and couplers tight and free of leaks. (Refer to Safety Guidelines – Hydraulic Safety).



Use caution when ascending or descending on the spreader. Wet shoes or boots are slippery.

## MAINTENANCE SAFETY

SAFETY  
INSTRUCTIONS

Follow all operating, maintenance, and safety instructions found in this Manual.



Before servicing, adjusting, repairing, or unclogging the machine, always make sure the tractor engine is stopped, key in your pocket, the machine is lowered to the ground, all controls are placed in neutral, the parking brake is set, and all the moving parts have stopped.



Use sufficient tools, jacks, and hoists that have the capacity for the job.



Use support blocks or safety stands when changing tires or performing maintenance.



Follow good shop practices of keeping the service area clean and dry, and use adequate light for the job at hand.



Before applying pressure to the hydraulic system, make sure all lines, fittings, and couplers are tightly secured and in good condition.



Make sure all shields/guards are in place and properly secured when performing maintenance.

## HYDRAULIC SAFETY

### SAFETY INSTRUCTIONS

**Follow all operating, maintenance, and safety instructions found in this Manual.**

Make sure components in the hydraulic system are kept clean and in good working condition.



Relieve pressure from the hydraulic system before servicing or disconnecting from the tractor.



Keep all hydraulic lines, fittings, and couplers tightly secured and free of leaks.



Replace any worn, cut, abraded, flattened, or crimped hoses.



Do not make any temporary repairs to the hydraulic lines, fittings, or hoses using tape, clamps, or cement. The hydraulic system operates under extremely high pressure and temporary repairs may fail suddenly and create a hazardous/dangerous situation.



Wear proper hand and eye protection when searching for a high-pressure hydraulic leak. Use a piece of wood or cardboard as a backstop instead of hands to identify and isolate a leak. If injured by a concentrated high-pressure stream of hydraulic fluid, seek medical attention immediately. Serious infection or toxic reaction can develop if hydraulic fluid penetrates the surface of the skin.



Before applying pressure to the system, make sure all components are tight and that the hydraulic lines, hoses, and couplings are not damaged.

## TRANSPORTATION SAFETY

### SAFETY INSTRUCTIONS

**Follow all operating and safety instructions found in this manual when transporting this equipment.**

Make sure the spreader complies with all local regulations regarding transporting equipment on public roads and highways.



Make sure the Slow Moving Vehicle (SMV) emblem and all lights and reflectors required by local highway and transportation authorities are properly in place, clean, and clearly visible to traffic.



Do not allow riders on any machinery during transport.

Make sure the spreader is securely attached to the tractor and install a safety chain to the spreader.

Make sure the tractor brake pedals are latched together.

Do not exceed 20 mph (32 km/h) when transporting the spreader. Always reduce speed on rough roads and surfaces, or when going down inclines.

Use caution when turning and always use the turn signals on the tractor to indicate your turning intentions to the other traffic.

The weight of the trailed machine should NEVER exceed the weight of the towing vehicle.

Check all clearances carefully whenever the machine is towed.

Set all features to transport position before transporting the spreader on the roadway.



Stay away from overhead obstructions and power lines during transport. Electrocution can occur even without direct contact.

## STORAGE SAFETY

### SAFETY INSTRUCTIONS

**Follow all operating and safety instructions found in this manual when storing this equipment.**



Store the spreader in an area away from human activity.



Do not permit children to play on or around the stored machine at any time.

Make sure that the spreader is stored in an area with a firm and level base to prevent the machine from tipping or sinking into the ground.



Block the wheels to prevent the machine from rolling.

**TIRE SAFETY****SAFETY  
INSTRUCTIONS**

Follow all operating and safety instructions found in this manual when working around tires.

Have only a qualified tire dealer or tire repair service perform tire repairs.

Do not attempt to install a tire on a wheel or rim unless you have the proper equipment and experience to do the job.

Do not substitute tires with a lesser road rating and/or capacity for the original equipment tires.

**WARNING**

**Explosive Force Hazard**  
Tire replacement, repair, and/or maintenance should be done by a qualified tire dealer or qualified repair service.

Failure to follow proper procedures when installing a tire on a wheel or rim can produce an explosive force that will result in serious injury or death.

Do not attempt to install a tire without proper equipment and experience to perform the job.

**ASSEMBLY SAFETY****SAFETY  
INSTRUCTIONS**

Follow all assembly, operating, and safety instructions found in this manual when assembly this equipment.



Use adequate manpower to perform assembly procedures safely.

Assemble the spreader in an area with sufficient space to maneuver the largest components and allow easy access to all sides of the machine.



Use only forklifts, lift cranes, jacks, and tools with sufficient capacity for the loads.



Do not allow spectators, especially children, in the working area.

**OPERATOR'S INSTRUCTIONS: MANURE SPREADER**

---

## **SAFETY**

### **READ THE OPERATOR'S MANUAL**

Any person who will be operating or maintaining this manure spreader should first read and understand this manual and all safety warnings on the unit.

This instruction manual should always be available to those responsible for the operation and maintenance of this manure spreader. It is the owner's responsibility to provide this safety information to his operators and employees.

Any person who does not understand the safety and operation instructions contained in this manual should not be considered qualified to operate this manure spreader.

### **FOLLOW SAFETY INSTRUCTIONS**

Specialized procedures and instructions are required and must be adhered to when working on this equipment. Failure to follow the instructions contained in this manual could result in server personal injury, death, and/or product or property damage. Personnel when operating and maintaining this equipment must use all applicable safety procedures such as OSHA requirements, regional, local safety codes/requirements, safe working practices, and good judgement.

# SAFETY

## OPERATING SAFETY PRECAUTIONS



WHEN THE SPREADER IS IN OPERATION, IT HAS MANY MOVING PARTS, WHICH COULD CAUSE SEVERE INJURY OR DEATH TO PERSONS COMING IN CONTACT WITH THESE PARTS. TO HELP AVOID SERIOUS ACCIDENTS, THE FOLLOWING GUIDELINES MUST BE FOLLOWED.

- **BE SURE ALL SAFETY SHIELDS** are in place before operating, including an truck and driveline shields. Exposed machinery, due to missing shielding, can cause severe injury or death. Repair or replace any damage or missing shields.
- **NEVER PUT ARMS OR FEET INSIDE UNIT**, or near discharge area, nor climb on or in the spreader while it is running. NEVER allow anyone to position themselves over or near the top, or near the discharge area of the spreader while it is running. Rotating beaters, shafting, belts, and sprockets can grab clothing or create pinch points, which can cause severe injury or death to the operator or bystanders. Always stop engine and remove ignition key so that the spreader cannot be accidentally turned on while inspection, servicing, or cleaning the spreader.
- **NEVER ATTEMPT TO RELEASE JAMMED MATERIALS OR CLEAN MATERIALS** from any area of the spreader or discharge without turning the spreader off first. Materials can hide moving parts and stopped parts can start unexpectedly, causing severe injury. Always stop engine and remove ignition key before attempting to remove jammed material or clean the spreader.
- **DO NOT ALLOW OPERATION OF THIS UNIT BY AN INEXPERIENCED OR UNQUALIFIED PERSON.** Keep all unqualified people away from the spreader during operation. Operators of this unit must be alert and use good judgment at all times and must have fully read and understand this manual.
- **DO NOT WEAR LOOSE OR FLOPPY CLOTHING** while operating this unit. Loose clothing may become entangled in moving or rotating machinery components.
- **BE SURE THE INSIDE OF SPREADER IS CLEAR** of any obstructions before loading.
- **SHOULD A PROBLEM OCCUR DURING THE OPERATION OF SPREADER, ALWAYS turn off engine and remove ignition key before investigating the problem.** If power source has not been turned off, the spreader may start unexpectedly, causing severe injury or death.



## **SAFETY**

### **TRANSPORTING SAFETY PRECAUTIONS**



**WHEN TRANSPORTING A LOADED SPREADER, USE REDUCED SPEED AND BE SURE THE VEHICLE HAS ADEQUATE BRAKES TO SAFELY STOP.**

- **DO NOT ALLOW ANYONE TO RIDE ON OR INSIDE THE SPREADER.**
- **REDUCE SPEED WHEN TRAVELING** loaded and/or over rough, soft, or wet terrain. Exercise caution on side slopes and when turning corners.
- **AVOID OPERATING THE SPREADER CROSSING GULLIES OR DITCHES.**
- **WHEN WORKING ON SLOPES** or inclines, travel uphill or downhill. Keep the transmission in gear when going downhill.
- **AVOID DRIVING ON** loose fill, rocks, inclines ditches, and holes.
- **ALWAYS PARK** the spreader on level ground and place wheel chocks ahead of and behind wheels.
- **IF UNIT IS FOR HIGHWAY TRANSIT** the end user is responsible for federal, state, and local vehicle safety regulation compliance (example: under ride requirements, lighting, and weight limitations.)
- **CLEAN OFF AND INSPECT** all traffic lights before entering a roadway.

### **SAFETY DECALS**

**SAFETY DECALS ARE PLACED ON THIS UNIT FOR THE PROTECTION OF THE OPERATOR OR ANY PERSON NEAR THE UNIT.**

- **BE SURE EVERYONE WHO OPERATES THE SPREADER UNDERSTANDS ALL THE INFORMATION, WARNING, CAUTION, AND DANGER DECALS.**
- **KEEP THE DECALS CLEAN** so they are readable. This applies to all caution, warning, and danger decals.
- **IT IS THE OWNER'S RESPONSIBILITY** to provide information for safe operation of this machine.
- **REPLACE ANY DAMAGED OR WORN DECALS.** Once any part of a decal becomes non-readable, it should be replaced. Replacements may be ordered through your dealer or Art's Way Manufacturing.
- **WHEN REPLACING DECALS,** be sure the surface area is clean and dry, peel the backing off the decal, and apply to the unit in the appropriate location. Be sure to wipe with clean cloth to rub out all air bubbles to assure a good seal. For the best adhesion decals should be applied in temperatures of 50°F or warmer.

## **MANURE SPREADER SAFETY**

**THERE ARE INHERENT HAZARDS ASSOCIATED WITH THE OPERATION OF A MANURE SPREADER. FOR YOUR SAFETY:**

- **ONLY PROPERLY INSTRUCTED PEOPLE SHOULD OPERATE THE SPREADER. DO NOT** allow children or inexperienced persons to operate spreader.
- **KEEP ALL GUARDS AND SHIELDS IN PLACE.** Moving parts can crush and dismember.
- **CLEAR THE AREA** before equipment start up.
- **KEEP HANDS, FEET, AND LOOSE CLOTHING AWAY FROM MOVING/ROTATING PARTS.**
- **DO NOT GO NEAR THE SPREADER WHILE THE MACHINE IS OPERATING.**
- **MAKE SURE THE PTO IS SECURELY LOCKED** to both the tractor and the spreader before operating unit.
- **DO NOT OPERATE PTO AT SPEEDS HIGHER** than manufacturer's recommendations.
- **HIGHWAY TRAFFIC IS NOT TO EXCEED 10 MPH** when loaded. The tires supplied are for farm use only and are not designed for use above this speed.
- **USE ADEQUATE SAFETY CHAINS** when towing the spreader.
- **USE OF HAZARD/FLASHING LIGHTS ARE REQUIRED** on all public roads. Obey all applicable highway safety laws and rules.
- **ALWAYS USE A TRACTOR LARGE ENOUGH TO PROVIDE SUFFICIENT BRAKING** assistance when towing a loaded spreader.
- **USE CAUTION WHEN TRAVELING** over uneven terrain and when approaching stops.
- **DO NOT LOAD THE SPREADER** unless it is completely hitched to the tractor.
- **DO NOT UNHITCH A LOADED SPREADER** from the tractor. Leaving it supported by only the jack.
- **PARK THE SPREADER ON LEVEL GROUND** and place wheel chocks ahead of and behind the wheels before unhooking from tractor to avoid unexpected rolling.
- **DO NOT ALLOW RIDERS ON THE SPREADER.**
- **DO NOT LIFT MANURE SPREADER BY THE BOX WELDMENT "D-RINGS".**
- **DO NOT WORK UNDERNEATH SLOP GATE** when raised.

## MANURE SPREADER SAFETY



**FAILURE TO HEED MAY RESULT IN SERIOUS PERSONAL INJURY OR DEATH THERE ARE ADDITIONAL HAZARDS ASSOCIATED WITH THE SERVICE AND MAINTENANCE OF YOUR SPREADER.**

### **FOR YOUR SAFETY:**

- **INSPECT** when first delivered and regularly thereafter; that all connections and bolts are tight and secure before operating.
- **RETIGHTEN ALL WHEEL BOLTS** after the first hour of towing. Check periodically thereafter. See [PG. 24] for proper torque values.
- **MAINTAIN PROPER TIRE AIR PRESSURE** at all times. Refer to tire manufacturer for proper pressure.
- **ALWAYS WEAR EYE PROTECTION** when operating or servicing spreader
- **BE SURE ALL MOVEMENT HAS STOPPED** and that the PTO is disconnected and the tractor is shut off before servicing the spreader or components.
- **ESCAPING HYDRAULIC FLUID UNDER PRESSURE** can penetrate skin and cause serious injury. Relieve all pressure from the hydraulic system before connecting or disconnecting the lines or making repairs. Check all hoses and fittings before start-up and periodically during operations.
- **NEVER MAKE ANY ALTERATIONS** or modification to this equipment.

**FAILURE TO HEED MAY RESULTS IN SERIOUS PERSONAL INJURY OR DEATH**

## **PRE-OPERATION**

### **IMPORTANT: READ BEFORE OPERATING SPREADER.**

**IT IS THE RESPONSIBILITY OF THE OWNER TO MAKE SURE THE SPREADER IS SET UP PROPERLY. THE FOLLOWING RECOMMENDATIONS SHOULD BE HELPFUL.**

- **CHECK FOR PROPER ASSEMBLY**, adjustment and lubrication. Check to be sure all bolts and setscrews are tight. Check to be sure that all belts and belt tighteners are properly adjusted. Review Operating Safety Precautions and Lubrication instructions for more information.
- **BE SURE ALL SHIELDS** are properly in place, including any drive-line/PTO shields
- **CHECK FOR AND REMOVE ANY FOREIGN OBJECTS** in the spreader box and discharge area.
- **BE SURE NO ONE IS NEAR THE SPREADER.**
- **TEST RUN THE SPREADER WHILE EMPTY**, start the apron and beaters. **RUN FOR AT LEAST 5 MINUTES.**
- **WITH SPREADER SHUT DOWN AND TRACTOR OFF, CHECK THE SPREADER DRIVE COMPONENTS TO BE SURE THEY ARE NOT ABNORMALLY HOT.**

If any of these items are not running as indicated, immediately repair or contact your service representative. Always refer to Operating Safety Precautions before operating or servicing the spreader.

## LUBRICATION

**ALWAYS STOP THE MANURE SPREADER AND DISCONNECT POWER BEFORE SERVICING, REPAIRING, OR CLEANING. USE SAFE SHOP PROCEDURE AND EXERCISE CAUTION WHEN WORKING ON THIS MACHINE.**

It is **extremely important to properly lubricate your new ART'S-WAY machine before it is used for the first time.** If the mechanical drive components of our unit are not protected from shock and frictional abrasion, the wear rate of these components will be vastly accelerated and their life span will be drastically reduced. For proper care and maintenance, your machine should be serviced with the fluids specified below.

It is **extremely important** that the lubrication guide be followed. For lubricating bearings, use good quality multi-purpose grease. Pump the grease in slowly. Apron chains should be lubricated with oil or spray-on chain lubricant and then operate the apron chain under a no-load condition (i.e. empty) to evenly coat lubricant. This will allow the chains to be thoroughly lubricated and thus minimize heat-up during operation.

DESCRIPTION	INTERVAL	LUBRICANT
APRON BEARINGS	15-20 HOURS	GREASE
APRON GEAR CASE	ANNUALLY	EP90 GEAR LUBE
APRON CHAIN	WHEN PARKED	30WT OIL
BEATER GEAR CASE	ANNUALLY	EP90 GEAR LUBE
UNIVERSAL JOINTS	15-20 HOURS	GREASE
AXLE HUBS	BI-ANNUALLY	GREASE
PTO SHAFTS	15-20	GREASE
SLIP CLUTCH	BI-ANNUALLY	GREASE
CAST FLANGE BEARINGS	15-20 HOURS	GREASE
PILLOW BLOCK BEARINGS	15-20 HOURS	GREASE
SLOP GATE PIVOT POINT	15-20 HOURS	GREASE

**ALWAYS REPLACE ALL SHIELDS AFTER MAINTENANCE AND LUBRICATION IS COMPLETE**

## **INSPECTION & ADJUSTMENTS**

**ALWAYS STOP SPREADER, SHUT OFF VEHICLE ENGINE AND REMOVE IGNITION KEY BEFORE SERVICING, REPAIRING, ADJUSTING, OR CLEANING. USE SAFE SHOP PROCEDURES AND EXERCISE CAUTION WHEN WORKING ON THIS MACHINE!**

- **SHIELDING** to be sure all shielding is in place and functioning properly. Replace all damaged or missing shielding immediately, contact your nearest dealer or the Art's Way Parts/Service dept. for more information.
- **SAFETY DECALS FOR READABILITY.** If any safety decals are removed, obstructed, or otherwise not understandable, they should be replaced immediately. Keep all decals clean!
- **AFTER A FEW HOURS OF INITIAL OPERATION,** check all nuts, bolts, and set screws to be sure they are tight and secure.
- **CHECK FREQUENTLY.** Thoroughly check all hardware each month or after 25 loads of use, torque to proper setting see [PG. 24] or replace if necessary.
- **CHECK BEATER TEETH.** Bolts must stay tight to prevent teeth from being flung from beaters. Look for wear on teeth and replace any that are worn out or damaged.
- **IMPORTANT: IF YOU WELD ON THIS UNIT:** Do Not allow the currents to flow through the bearings, ground directly to the item being welding/repared.
- **PERIODICALLY CHECK** all bearings and bushings for wear and replace if necessary.
- **INSPECT APRON CHAINS** for wear, proper alignment, and tension, according to the adjustment guidelines shown on [PG. 21] before every day of operation.

## APRON TENSION ADJUSTMENT GUIDELINES

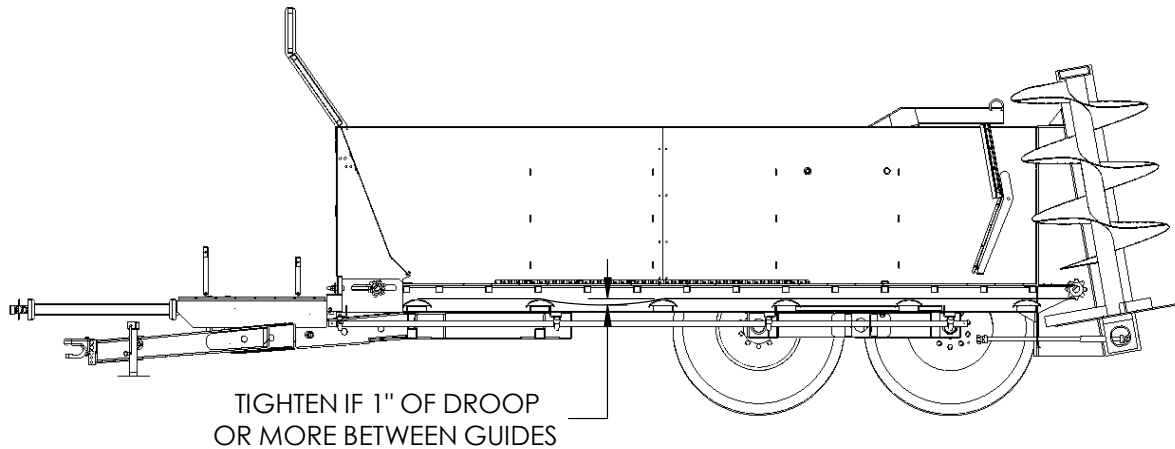

**BE SURE TO KEEP PROPER TENSION ON APRON CHAINS.** The (2) Apron Chain tightener bolts are located in the front of the unit at each side of Apron Shaft. They should be adjusted evenly to help keep proper chain alignment.

If Apron Chain is loose, remove one length from each side of Apron Chain assembly and readjust to tension as shown above.

**CAUTION:** Over tightening can cause premature failure of the chain and drive components.

## DEALER SETUP REMINDERS

If the spreader is delivered with running gear assembled (towed) and has the floatation tire option installed please take note of the tread direction. Floatation tires may be installed with “forward pointing” tread direction to decrease floatation properties when in transit to distant destinations. Tires should be installed with “backward pointing” tread direction before unit is delivered to end-user to increase floatation performance in field.



## OPERATION

**WARNING:** Before operation, be sure no one is near the spreader and the discharge area is clear of objects or persons that could be harmed if material is discharged!

**WARNING:** MAKE SURE THAT ALL PARTS HAVE STOPPED MOVING, IGNITION KEY IS OFF AND REMOVED BEFORE MAKING ANY ADJUSTMENTS, MAINTENANCE OR REPAIRS ARE MADE.

1. Verify the “apron reverse speed” knob on the manifold is turned all the way to the “-”/clockwise position to prevent the Apron Chain from being ran in the reverse direction accidentally.

**CAUTION:** Never attempt to run the Apron Chain in reverse with a full load, as this could cause damage to chain or drives. The “apron reverse speed” knob should be locked in the “-”/clockwise position unless there is a need to clear the Beaters and should be returned to the “-”/clockwise position as soon as Beaters are cleared.

2. With the vehicle stopped and engine throttled down, slowly engage the PTO to start spinning the Beaters.

3. Raise the Slop Gate to desired height for your preferred spreading density using hydraulic control connected to the “GREEN” hose ends.

NOTE: Slop Gate height can be adjusted to vary the spreading density.

4. Engage the Apron Chain, in the forward direction, using the hydraulic control connected to the “BLACK” hose ends. **NEVER engage Apron Chain with Slop Gate in the fully closed position.**

NOTE: “Apron forward speed” knob can be adjusted to change the speed of the Apron Chain to help control flow of material to Beaters. (Counter-Clockwise=FASTER, Clockwise=SLOWER)

5. Once material starts to contact the Beaters, start tractor in motion and set to the speed that allows for preferred spreading density.

6. After all the material is spread, turn off the Apron Chain, close the Slop Gate, and shut down the PTO/Beaters.

Refer back to the LOADING section for any loading help.



## **BEATER MAINTENANCE**

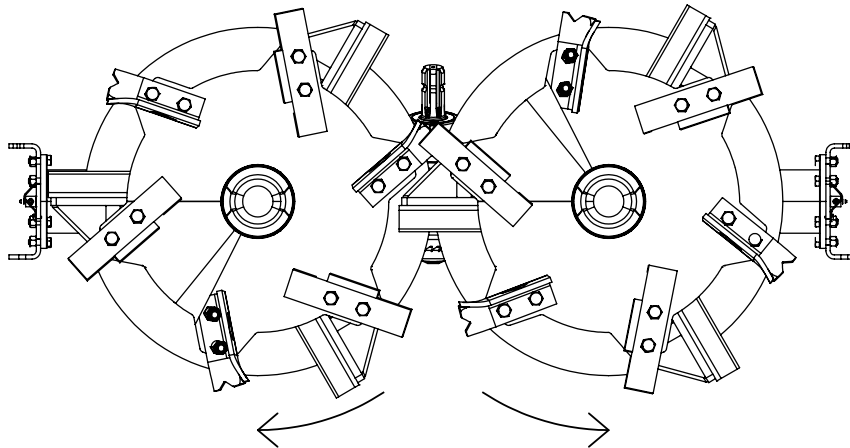

**WARNING:** MAKE SURE THAT ALL PARTS HAVE STOPPED MOVING, IGNITION KEY IS OFF AND REMOVED BEFORE MAKING ANY ADJUSTMENTS, MAINTENANCE OR REPAIRS ARE MADE.

- **BEFORE EVERY DAY OF USE**, all beater teeth, knives, and scoop hardware should be inspected for damage or signs of loosening. Replace worn or damaged hardware and refer to [PG. 24] TORQUE VALUES or equivalent hardware torque chart for loose hardware.
- **REPLACE** teeth, knives, and scoops when worn or damaged, they should be replaced in order to keep the corresponding beater shaft as balanced as possible.
- **CHECK OIL LEVEL** in beater gearbox before every day of use, add when needed to proper level in sight plug. Recommend changing oil in gearbox annually see [PG. 19] LUBRICATION.
- **GREASE BEARINGS DAILY.** Inspect grease lines for damage or wear.
- **REMOVE ANY ENTANGLEMENTS** from beaters to limit potential damage to beaters.

**CAUTION:** If any repairs need welding, ground to nearest spot of repair. Be sure no bearings or gearboxes are in between welder and ground connection.

## TORQUE VALUES

Follow the chart below for general torque values.

**-Tandem flange lug nuts (5/8-18) should be torqued to 200 FT LBS.**

**-Single lug nuts (3/4-16) should be torqued to 400 FT LBS.**

SIZE	GRADE 5		GRADE 8	
	PLAIN TORQUE (K=.20)	ZINC TORQUE (K=.17)	PLAIN TORQUE (K=.20)	ZINC TORQUE (K=.17)
INCH POUNDS				
4-40	8	7	12	11
4-48	9	8	13	12
6-32	16	14	23	20
6-40	18	16	25	22
8-32	30	26	41	36
8-36	31	27	43	38
10-24	43	38	60	53
10-32	49	43	68	60
1/4"-20	96	86	144	126
1/4"-28	120	103	168	144
FOOT POUNDS				
5/16"-18	17	15	25	21
5/16"-24	19	16	27	23
3/8"-16	31	26	44	37
3/8"-24	35	30	49	42
7/16"-14	49	42	70	59
7/16"-20	55	47	78	66
1/2"-13	75	64	106	90
1/2"-20	85	72	120	102
9/16"-12	109	92	154	130
9/16"-18	121	103	171	146
5/8"-11	150	128	212	180
5/8"-18	170	144	240	204
3/4"-10	267	227	376	320
3/4"-16	297	253	420	357
7/8"-9	429	365	606	515
7/8"-14	474	403	669	568
1"-8	644	547	909	772
1"-12	722	614	1020	867
1-1/8"-7	800	700	1280	1120
1-1/8"-12	880	770	1440	1260
1-1/4"-7	1121	952	1817	1545
1-1/4"-12	1241	1055	2012	1710
1-3/8"-6	1460	1280	2380	2080
1-3/8"-12	1680	1470	2720	2380
1-1/2"-6	1950	1657	3162	2688
1-1/2"-12	2194	1865	3557	3024
TORQUE VALUES AQUIRED FROM SABRE INDUSTRIAL SUPPLIES AND FASTENAL				

**ILLUSTRATED PARTS LIST: MANURE SPREADER**

TONGUE TO BOX ASSEMBLY

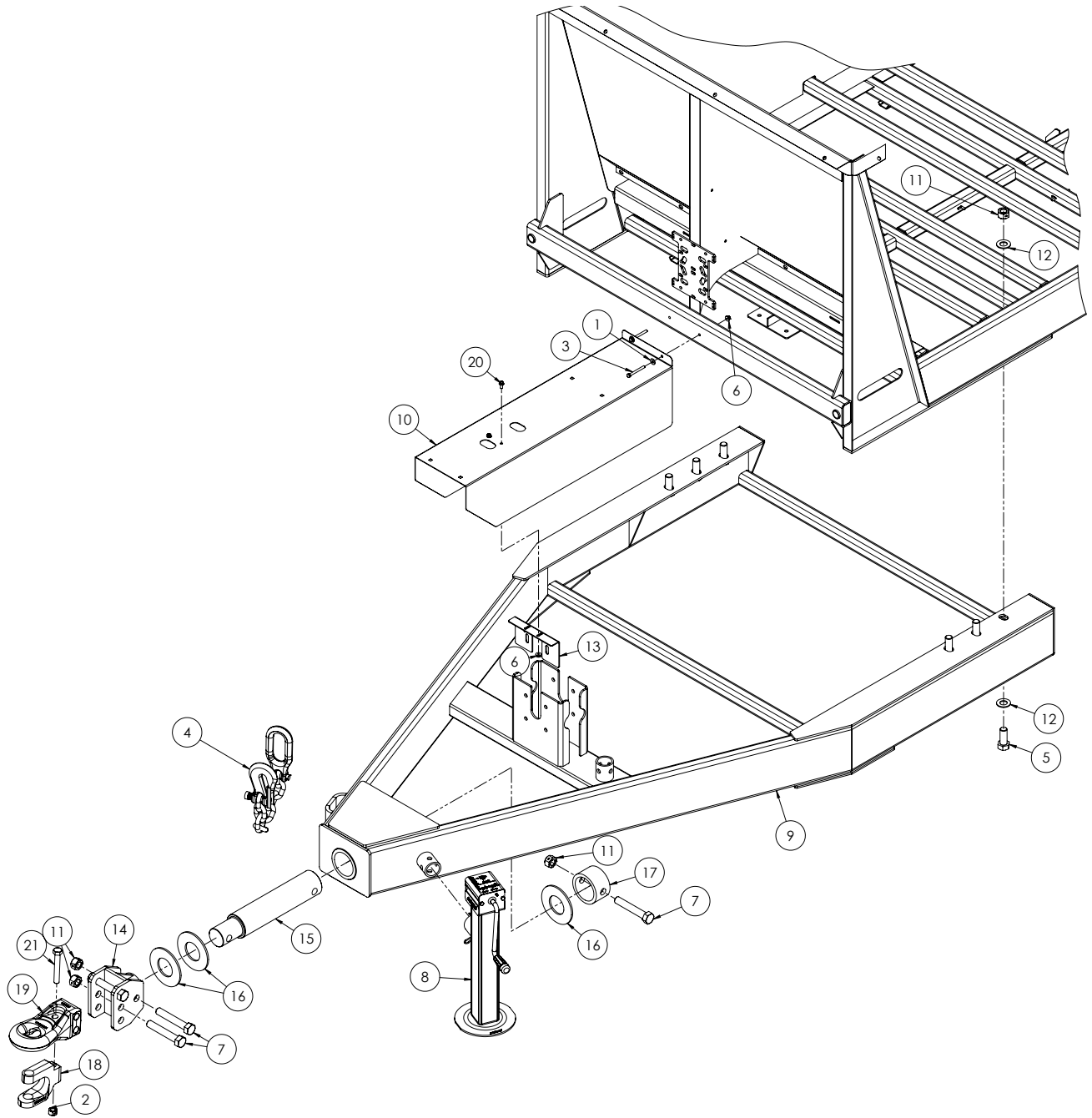

<b>ITEM NO.</b>	<b>PART NUMBER</b>	<b>DESCRIPTION</b>	<b>QTY.</b>
1	022920	WASHER, FLAT 5/16 STD	2
2	152360	NUT, LOCK 3/4-10 HEX	1
3	160230	BOLT, HHCS 5/16-18 X 3 GR5	2
4	472910	CHAIN ASSY, SAFETY	1
5	497590	BOLT, HHCS 1-8 X 3 GR8	6
6	600110	NUT, HFH NYLOC 5/16-18	4
7	600490	BOLT, HHCS 1-8 X 6"	4
8	630900	JACK, NICKEL PLATED	1
9	725600	TONGUE WLDT,	1
10	725659	SHIELD, PTO DRIVE	1
11	990510	NUT, LOCK 2-WAY 1-8	10
12	1107389	WASHER, FLAT 1 SAE	12
13	H160025-04	SUPPORT, PTO SHIELD	1
14	H160071	HITCH RECEIVER	1
15	H160075	SWIVEL SHAFT	1
16	H160076	SWIVEL HITCH WASHER	AR
17	H160077	SWIVEL HITCH STOP	1
18	HH76-02-8199	HITCH, CLEVIS	1
19	HH76-02-8238	HITCH, CAT4 AUSTEMPERED	1
20	JN10212	SCREW, FLG 5/16-18 X 3/4	2
21	P99440	BOLT, HHCS 3/4-10 X 5-1/2", GR8	1

**RUNNING GEAR TO BOX ASSEMBLY - SINGLE**

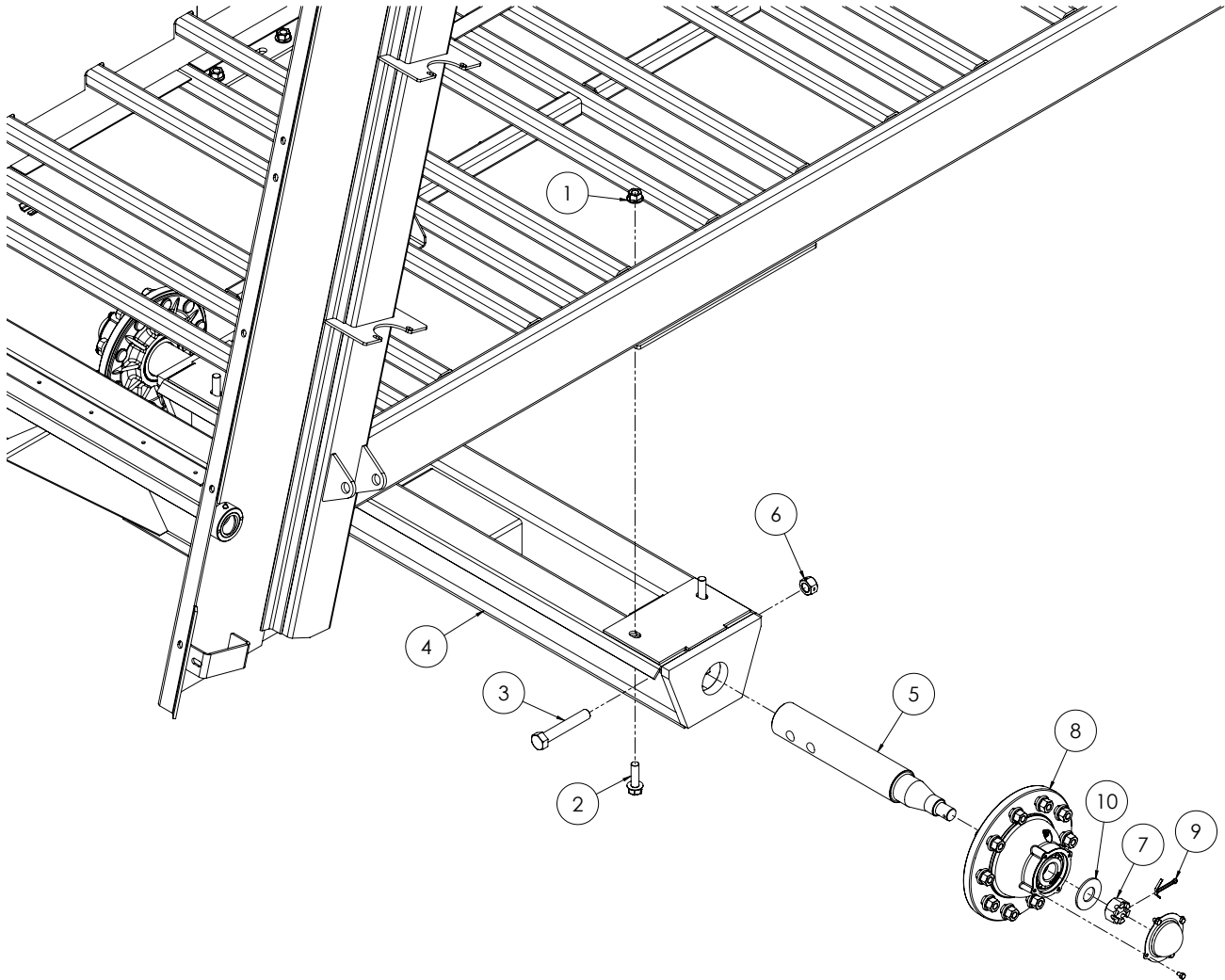

<b><u>ITEM NO.</u></b>	<b><u>PART NUMBER</u></b>	<b><u>DESCRIPTION</u></b>	<b><u>QTY.</u></b>
1	600160	NUT, HFH TOPLOCK 3/4-10	4
2	600430	BOLT, HFH 3/4-10 X 2-1/2"	4
3	600490	BOLT, HHCS 1-8 X 6"	4
4	725660	AXLE WLDT, MAIN	1
5	725702	SPINDLE, SHAFT	2
6	990510	NUT, LOCK 2-WAY 1-8	4
7	E552023	NUT, SLOTTED 1-1/4 12 GR5	2
8	691080	HUB ASSEMBLY,	2
9	MP906827	.25"X 3" COTTER PIN	2
10	R61502	WASHER,FLAT 1-3/8" STD	2

HUB ASSEMBLY - SINGLE

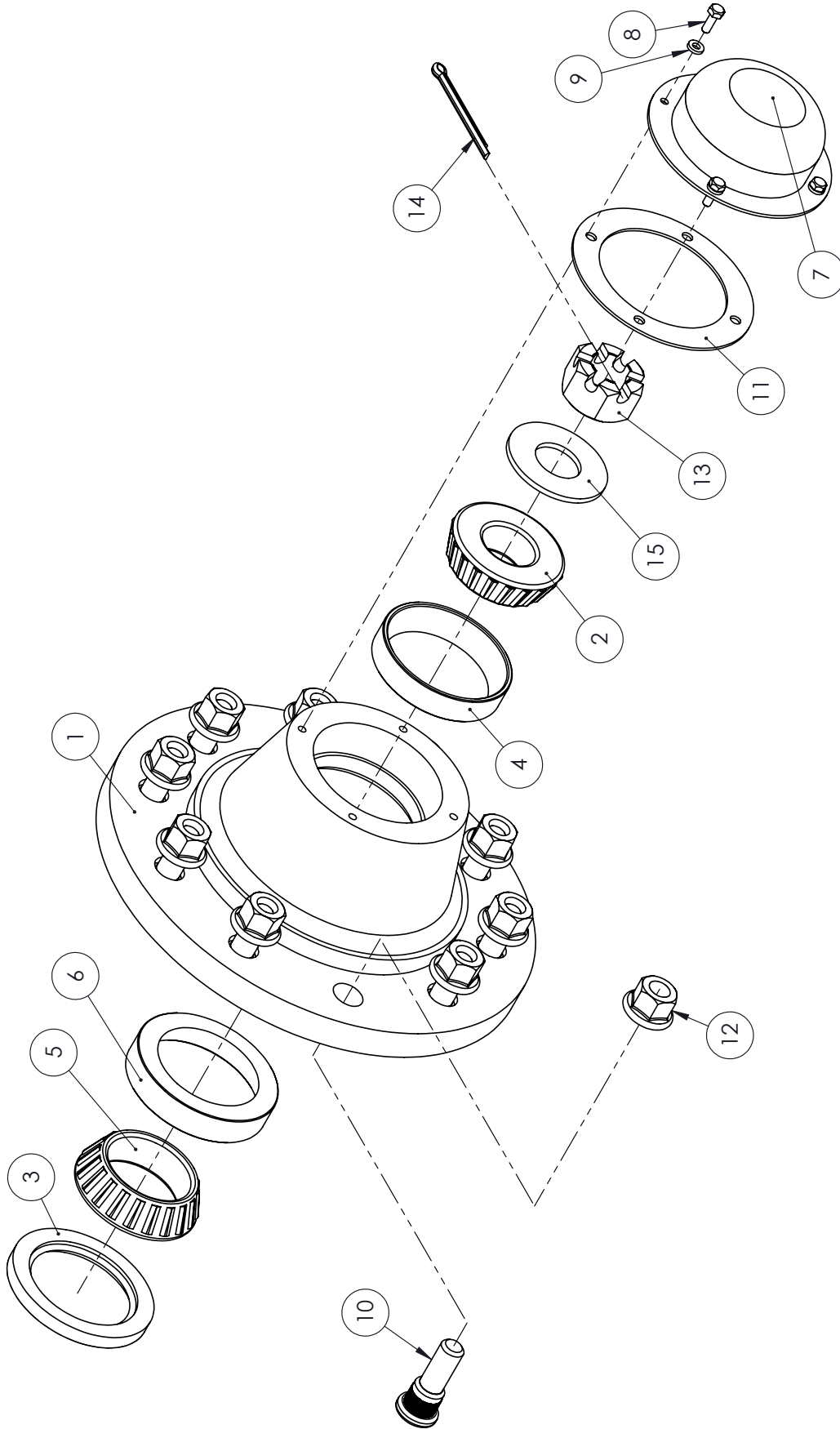



<b>ITEM NO.</b>	<b>PART NUMBER</b>	<b>DESCRIPTION</b>	<b>QTY.</b>
1	HN69-05-4072	873 HUB CASTING W/ STUDS & RACES	1
2	HN69-02-4045	OUTSIDE BEARING #460	1
3	HN69-02-4028	GREASE SEAL #33464 SA	1
4	HN69-02-4068	OUTSIDE BEARING RACE #453A	1
5	HN69-02-4064	INSIDE BEARING #33275	1
6	HN69-02-4066	INSIDE BEARING RACE #33462	1
7	HN69-02-4030	4-BOLT DUST CAP	1
8	HZ82-03-0412	5/16" HEX HEAD BOLT, .75"	4
9	HZ82-66-0404	WASHER, LOCK SPLIT, 1/4" Z5 (OPTIONAL)	4
10	HN69-02-4061	WHEEL, STUD 3/4"	10
11	455750P	GASKET, HUB	1
12	455740P	NUT, HEX FLANGE, 3/4-10 HUB	10
13	E552023	NUT, SLOTTED 1-1/4 12 GR5	1
14	MP906827	.25"X 3.00" COTTER PIN	1
15	R61502	WASHER, FLAT 1.375	1

**WHEEL ASSEMBLY (USED MILITARY) - SINGLE**

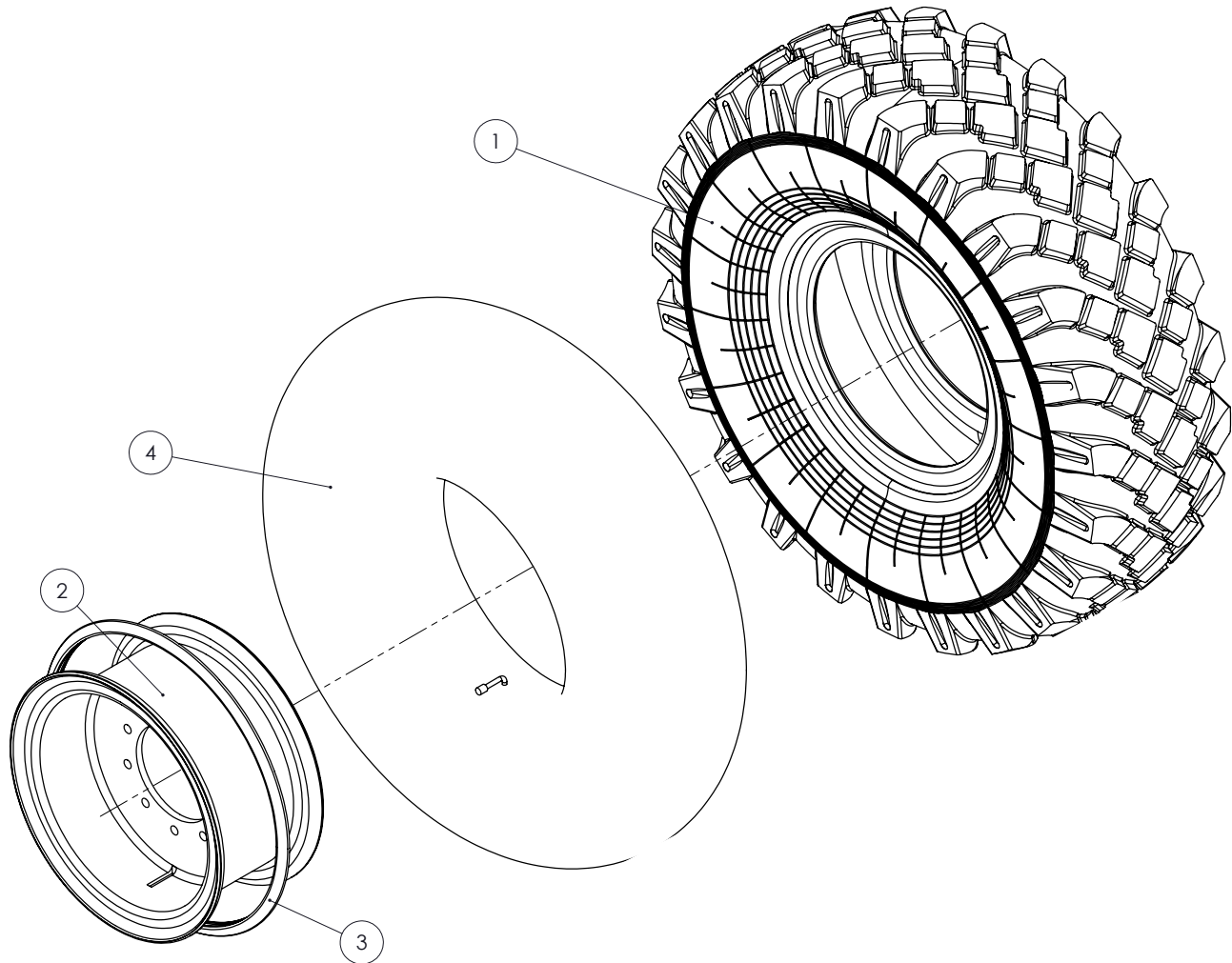

<u>ITEM NO.</u>	<u>PART NUMBER</u>	<u>DESCRIPTION</u>	<u>QTY.</u>
1	HN69-07-4073	TIRE, 425/65RX22.5	1
2	HN69-07-4074	RIM, 16R20	1
3	606100	L RING, WHEEL LOCKING	1
4	606105	TUBE, INNER W/ STEM	1

WHEEL ASSEMBLY (FLOATATION) - SINGLE

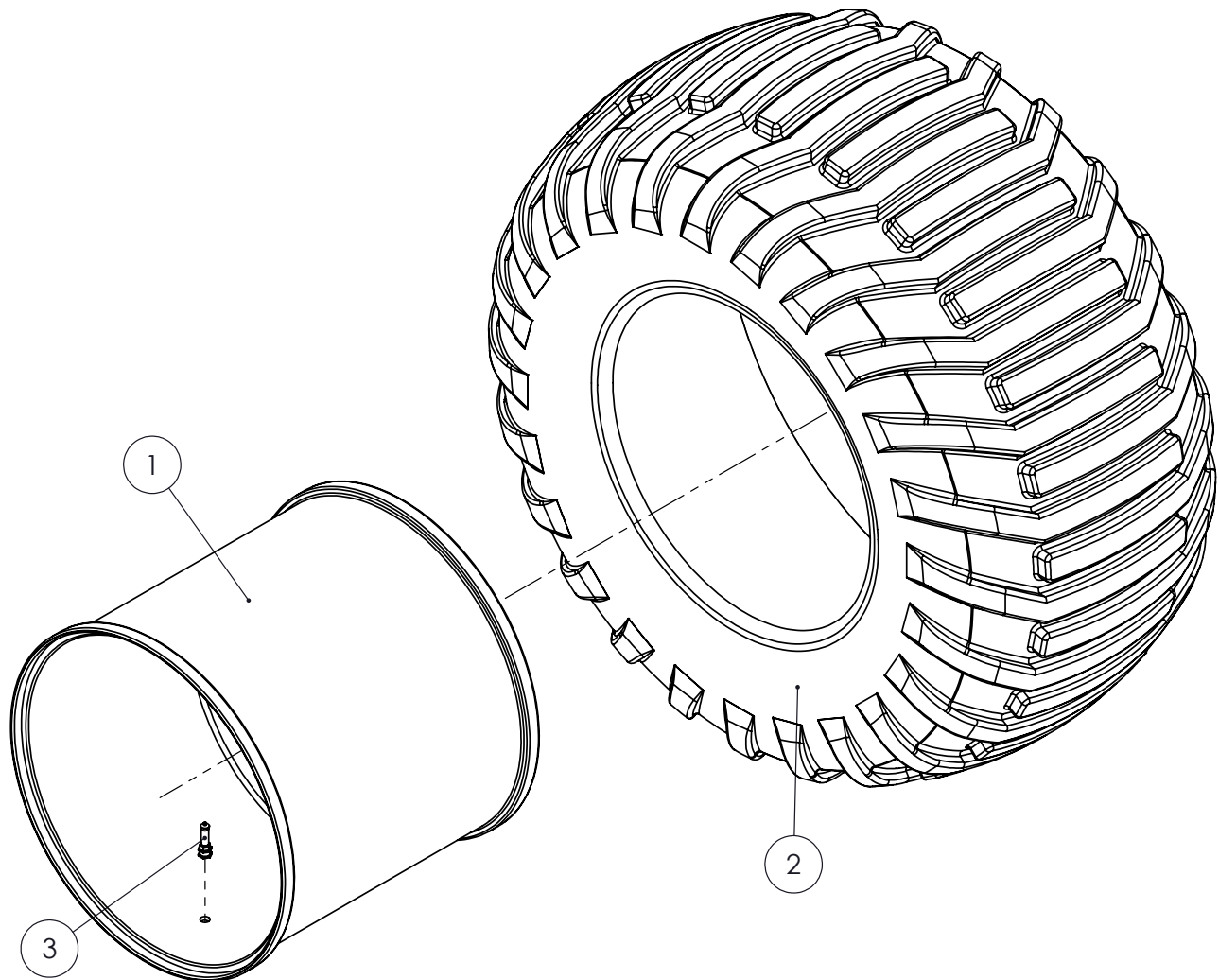

<u>ITEM NO.</u>	<u>PART NUMBER</u>	<u>DESCRIPTION</u>	<u>QTY.</u>
1	659005	RIM, 22.5"X20"	1
2	MP12.11073	TIRE, 600/50R22.5 (GOODYEAR BRAND)	1
	690619	TIRE, 600/50/R22.5 (BKT BRAND)	1
3	269490	STEEL VALVE STEM	1
	690621	WHEEL/TIRE ASSY, 20" RH(BKT)	-
	690622	WHEEL/TIRE ASSY, 20" LH(BKT)	-
	690623	WHEEL/TIRE ASSY, 20" RH(GOODYEAR)	-
	690624	WHEEL/TIRE ASSY, 20" LH(GOODYEAR)	-
NOTE: SEE OPERATOR'S [PG. 21] FOR TREAD DIRECTION.			

RUNNING GEAR TO BOX ASSEMBLY - TANDEM

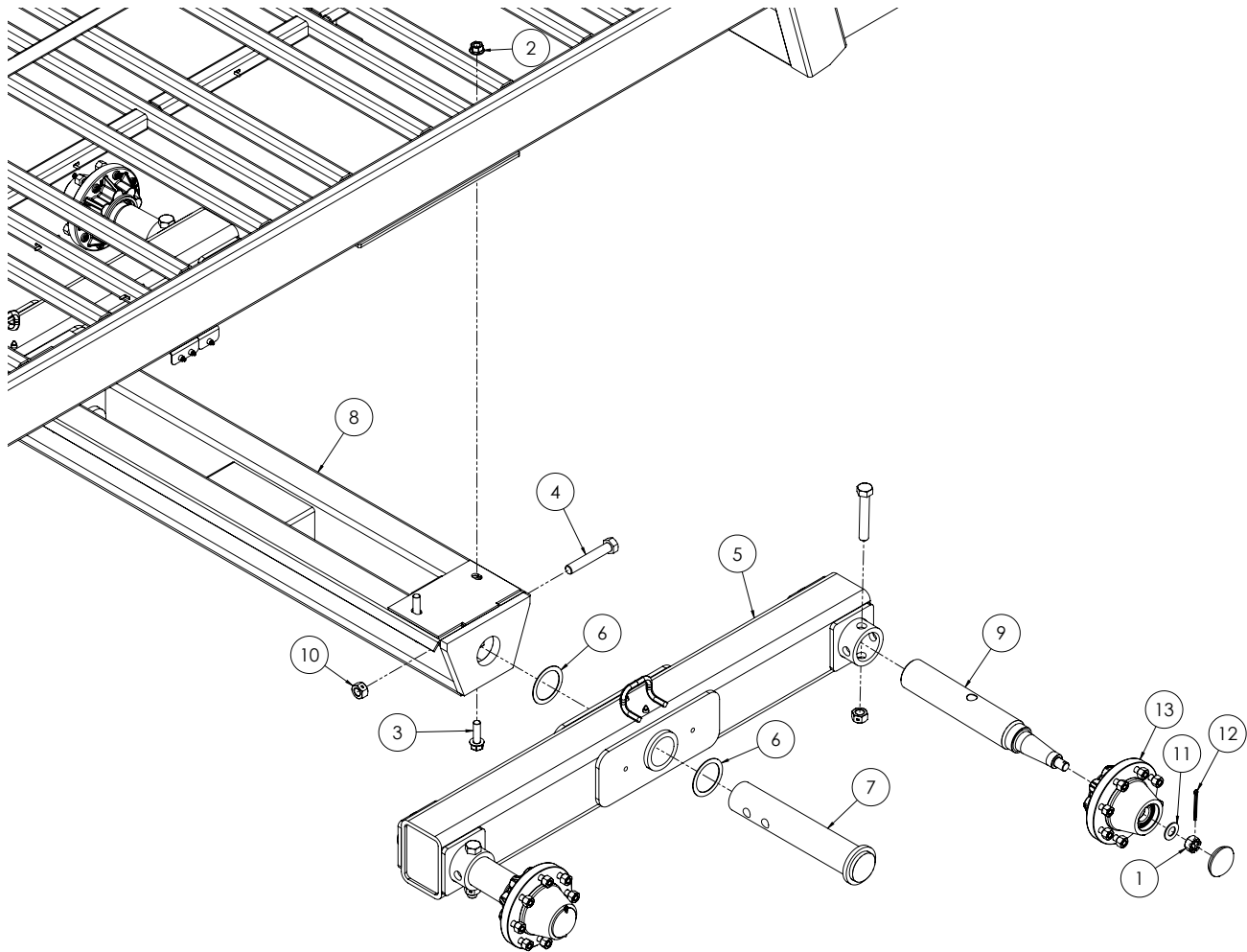

<b>ITEM NO.</b>	<b>PART NUMBER</b>	<b>DESCRIPTION</b>	<b>QTY.</b>
1	344280	NUT, CASTLE 1-14	4
2	600160	NUT, HFH TOPLOCK 3/4-10	4
3	600430	BOLT, HFH 3/4-10 X 2-1/2"	4
4	600490	BOLT, HHCS 1-8 X 6"	8
5	638600	TANDEM WLDT, ROCKER	2
6	690670	SHIM, TANDEM ROCKER	4
7	690785	TANDEM ROCKER PIN WLDT,	2
8	725660	AXLE WLDT, MAIN	1
9	725716	SPINDLE, TANDEM	4
10	990510	NUT, LOCK 2-WAY 1-8	8
11	1107389	WASHER, FLAT 1 SAE	4
12	MP906827	.25"X 3" COTTER PIN	4
13*	MP19.00067	HUB ASSY, 8 BOLT (COMPLETE W/ BRGS/SEAL)	4
*COMPLETE HUB ASSY COMES W/ TAPER LUG NUTS			

HUB ASSEMBLY - TANDEM

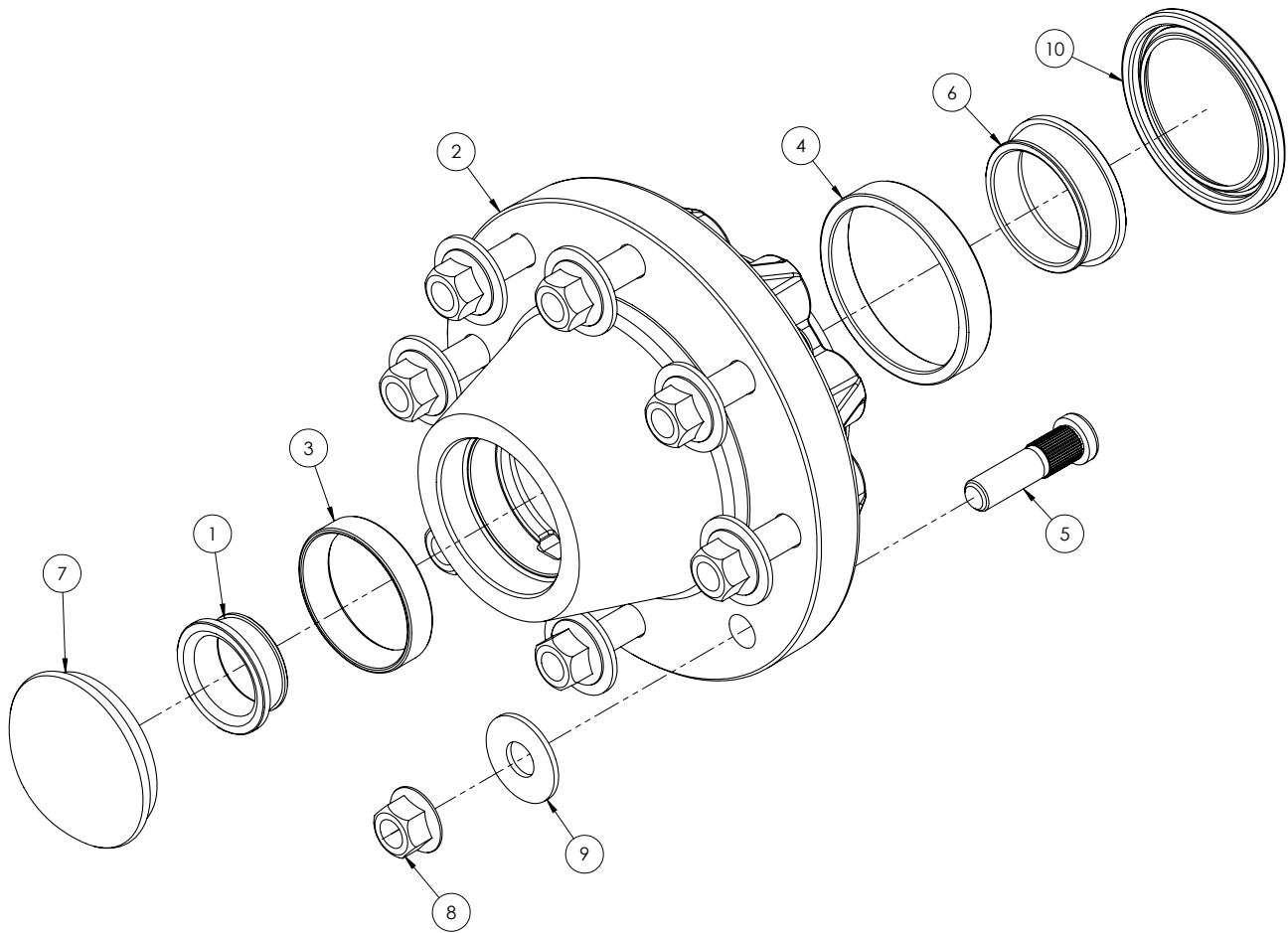

<u>ITEM NO.</u>	<u>PART NUMBER</u>	<u>DESCRIPTION</u>	<u>QTY.</u>
1	007600	BEARING CONE	1
2	MP19.00081	MACHINED HUB W/ BRG CUPS	1
3	018930	BEARING CUP	1
4	MP19.00084	BEARING CUP	1
5	MP19.00085	STUD, WHEEL 5/8-18	8
6	MP19.00083	BEARING CONE	1
7	MP903205	CAP, DUST	1
8	MP907730	NUT -5/8-18 GR8	8
9	MP907731	WASHER, FLAT 5/8" GR8	8
10	MP19.00082	OIL SEAL - 3	1

## WHEEL ASSEMBLY (FLOATATION) - TANDEM

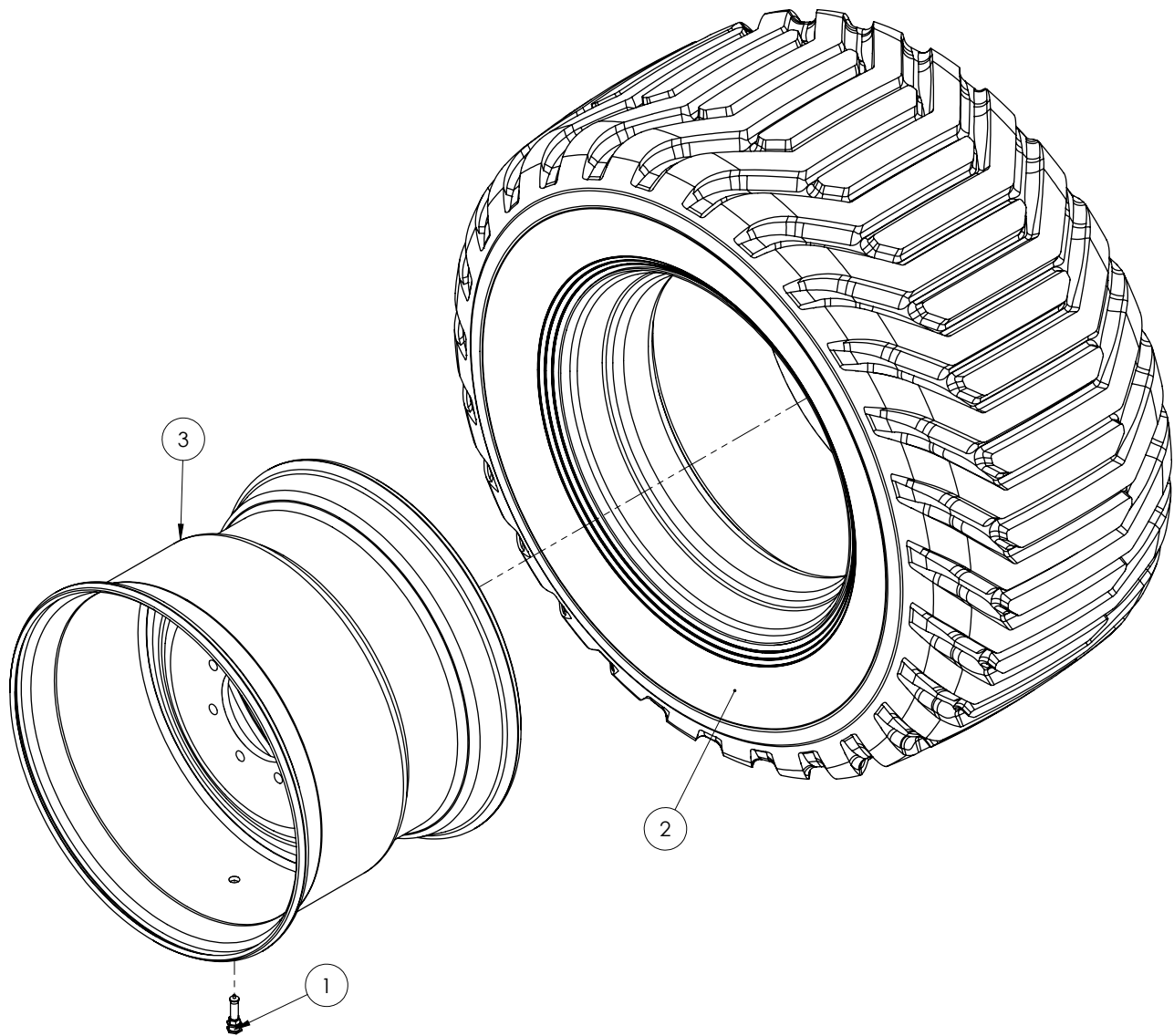

<u>ITEM NO.</u>	<u>PART NUMBER</u>	<u>DESCRIPTION</u>	<u>QTY.</u>
1	269490	STEEL VALVE STEM	1
2	725717	TIRE, FLOATATION	1
3	725718	RIM, WHEEL	1



WHEEL ASSEMBLY (SUPER SINGLE) - TANDEM

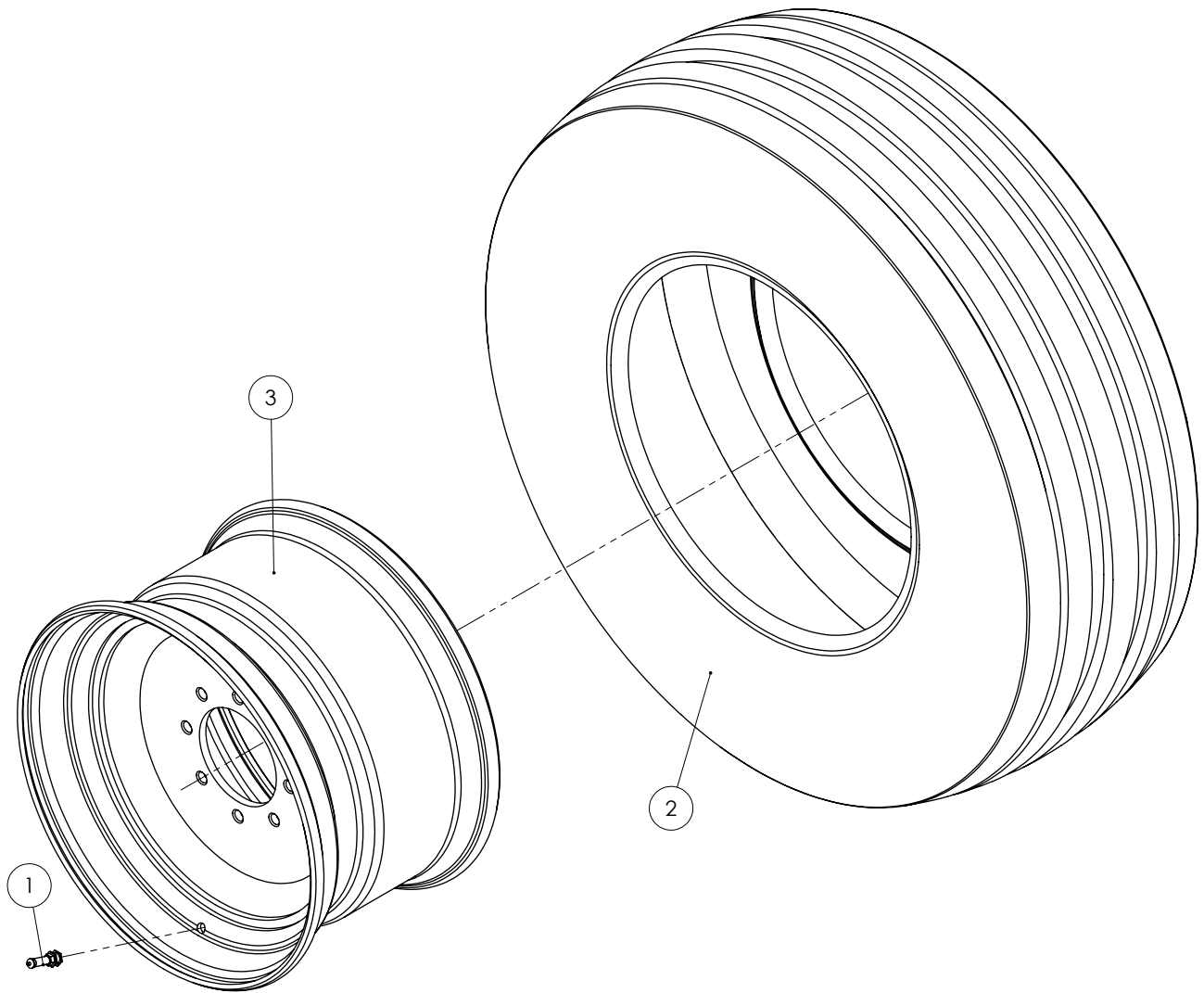

<u>ITEM NO.</u>	<u>PART NUMBER</u>	<u>DESCRIPTION</u>	<u>QTY.</u>
1	269490	STEEL VALVE STEM	1
2	MP12.09999	TIRE, 425/65RX22.5	1
3	MP12.10506	RIM, 22.5X13 8-BOLT	1

DRIVELINE ASSEMBLY

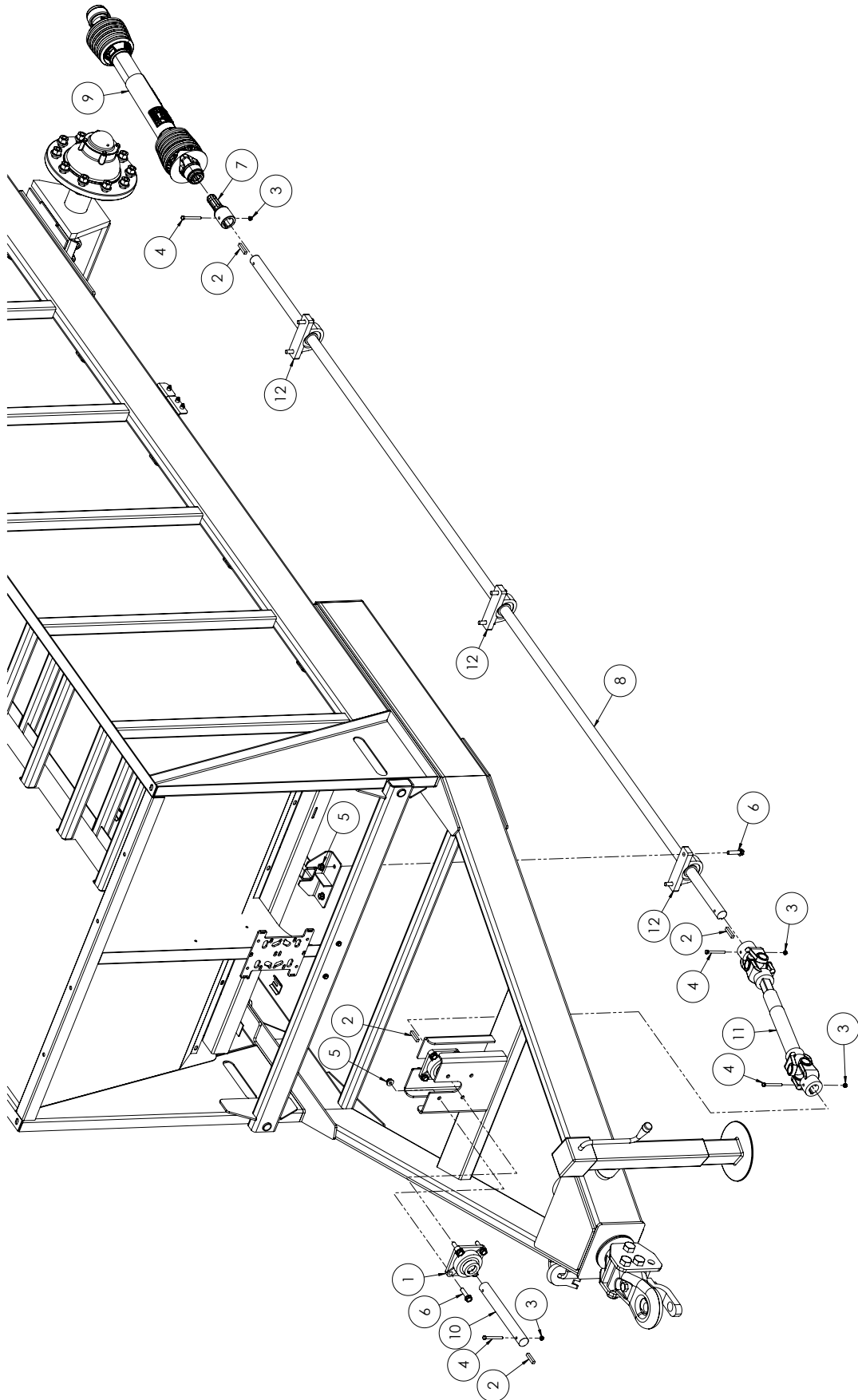

<u>ITEM NO.</u>	<u>PART NUMBER</u>	<u>DESCRIPTION</u>	<u>QTY.</u>
1	010560	BEARING ASSEMBLY (COMPLETE)	2
	I478037R92	BEARING INSERT W/ LOCK COLLAR	
2	021530	KEY, SQUARE 3/8 X 2	4
3	025670	NUT, LOCK 5/16-18	4
4	160230	BOLT, HHCS 5/16-18 X 3 GR5	4
5	600140	NUT, HFH NYLOC 1/2-13	14
6	600240	BOLT, HFH 1/2-13 X 2.00"	14
7	607060	PUMP ADAPTER,	1
8	725699	SHAFT, DRIVELINE	1
9	H140049	PTO, REAR DRIVELINE	1
10	H160028	PTO DRIVE SHAFT	1
11	H160073	SLIP SLEEVE SHAFT ASSY	1
12	HK08-55-1027	BEARING, 1.50", PILLOW BLOCK	3

35R DRIVE SHAFT WITH GUARD (TO BEATERS)

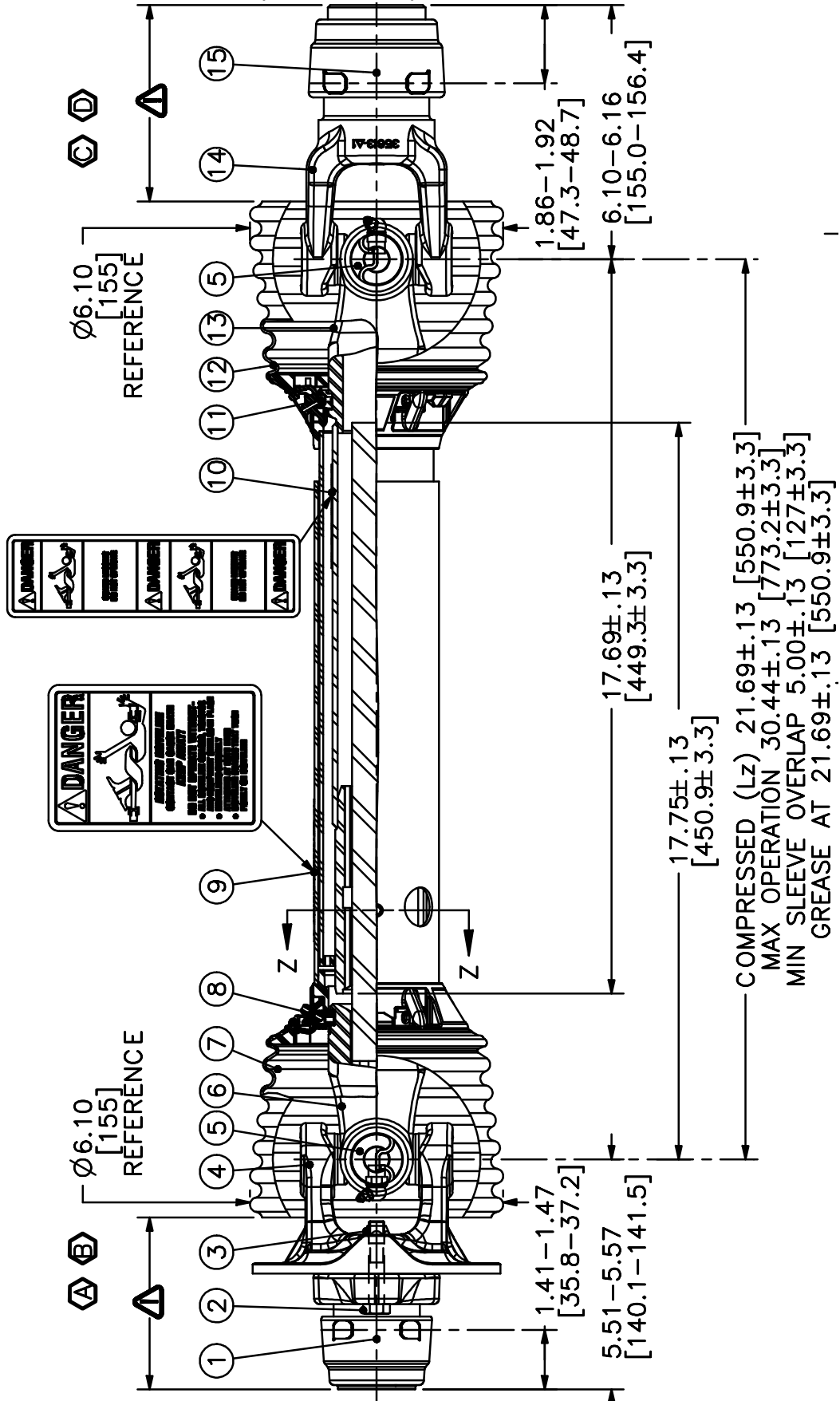

<b>ITEM NO.</b>	<b>PART NUMBER</b>	<b>DESCRIPTION</b>	<b>QTY.</b>
A	H93-25686	JOINT A SHAFT HAU- ASM. */GUAM	1
B	H95-25686	JOINT A SHAFT MTF ASM.	1
C	H92-25686	JOINT * TUBE HALF ASM. W/GUARD	1
D	H94-25686	JOINT * TUBE HHF ASK.	1
1	H26-15120	SSL/AUTO-LOK REPAIR KIT	1
2	H11-10483	BOLT, 3/8-16 X 2.00 LG., GR. 5	1
3	H11-10035	LOCKNUT, 3/8-16	1
4	H40-10139	BALL SHEW ASM.	1
5	H03-10045	35R CROSS KIT	2
6	H99-25686	YOKE A SHAFT (1.19 SO.)	1
7	H97-25686	OUTER GUARD	1
8	H19-11146	GUARD REPAIR KIT	1
9	H13-10021	SAFETY SIGN	1
10	H13-10022	SAFETY SGN	1
11	H19-11147	GUARD REPAIR KIT	1
12	H96-25686	INNER GUARD	1
13	H98-25686	YOKE. TUBE * SUP SLEEVE	1
14	H35610-1005	SAFETY SUDE LOCK ASM.	1
15	H26-13387	SSL/AUTO-LOK REPAIR KIT	1



<b>ITEM NO.</b>	<b>PART NUMBER</b>	<b>DESCRIPTION</b>	<b>QTY.</b>
A	H95-25413	JOINT & SHAFT HALF ASM.	1
B	H94-25413	JOINT & TUBE HALF ASM.	1
1	H35040-1003	YOKE	2
2	H03-10045	35R CROSS KIT	2
3	H99-25413	YOKE & SHAFT (1.19 SQUARE)	1
4	H98-25413	YOKE, TUBE, & SLIP SLEEVE	1

1000 RPM 1-3/8 X 21 SPLINE C-V PTO W/CLUTCH PACK

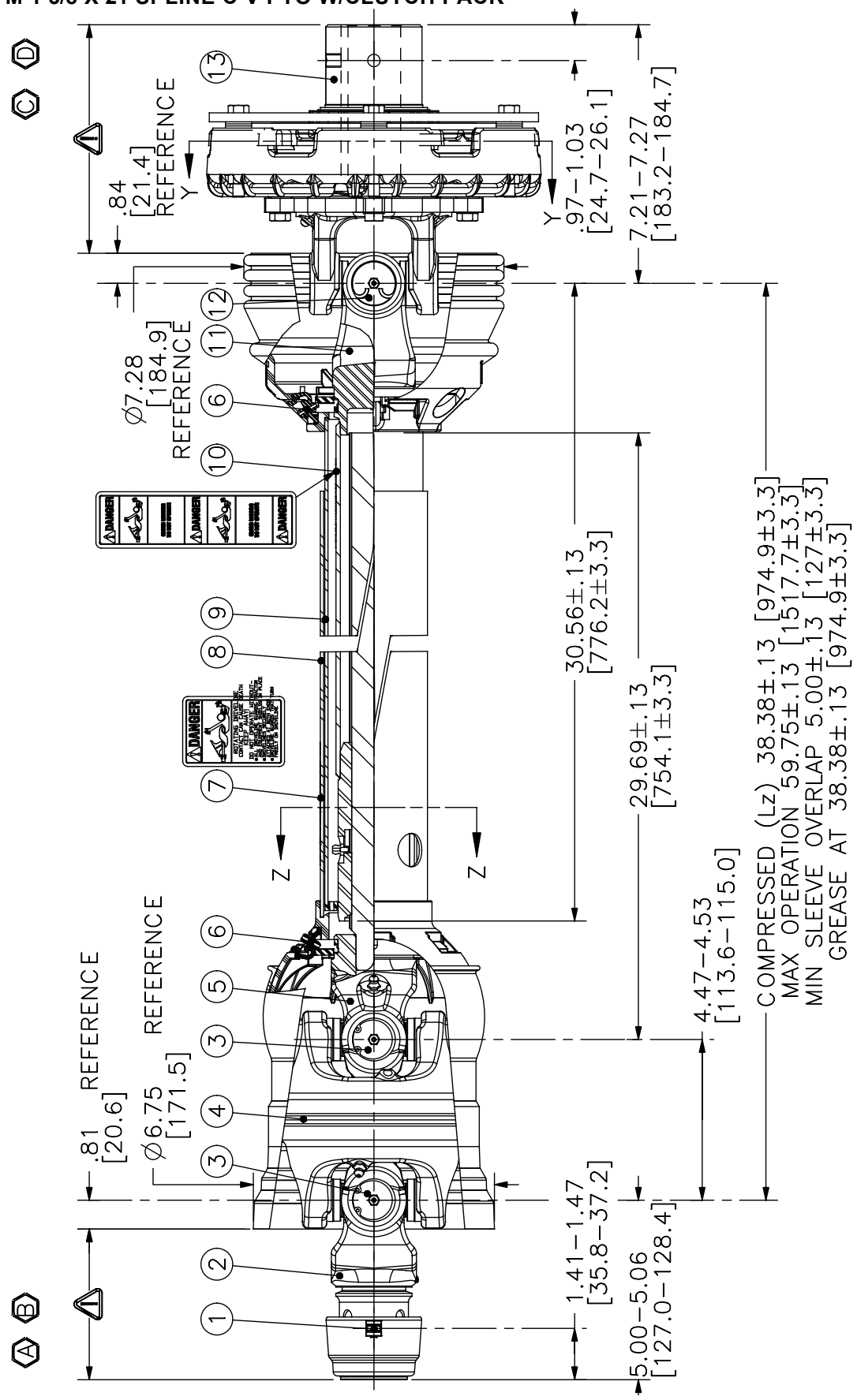



<b>ITEM NO.</b>	<b>PART NUMBER</b>	<b>DESCRIPTION</b>	<b>QTY.</b>
A	H93-25415	JOINT & SHAFT HALF ASM. W/GUARC	1
B	H95-25415	JOINT IJC SHAFT HALF ASM.	1
C	H92-25415	JOINT & TUBE HALF ASM. W/GUARD	1
D	H94-25415	JOINT & TUBE HALF ASM.	1
1	H26-15120	SSL/AUTO-LOK REPAIR KIT	1
2	H86810-1016	WWCV AUTO-LOK YOKE ASM.	1
3	H03-15436	AB6/AW22/CAT 4 80-EBL CROSS KIT	2
4	H26-15159	WWCV CENTER HOUSING	1
5	H99-25415	WWCV YOKE ST SHAFT (1.31-20 SPINE)	1
6	H19-15126	GUARD REPAIR KIT	2
7	H13-10021	SAFETF SIGN	1
8	H97-25415	OUTER GUARD	1
9	H96-25415	INNER GUARD	1
10	H13-10022	SAFETT SIGN	1
11	H98-25415	YOKE. TUBE, & SUP SLEEVE	1
12	H03-15287	35EBL CROSS KIT	1
15	H38-15088	FRICTION CLUTCH ASM.	1

1000 RPM 1-3/4 X 20 SPLINE C-V PTO W/CLUTCH PACK

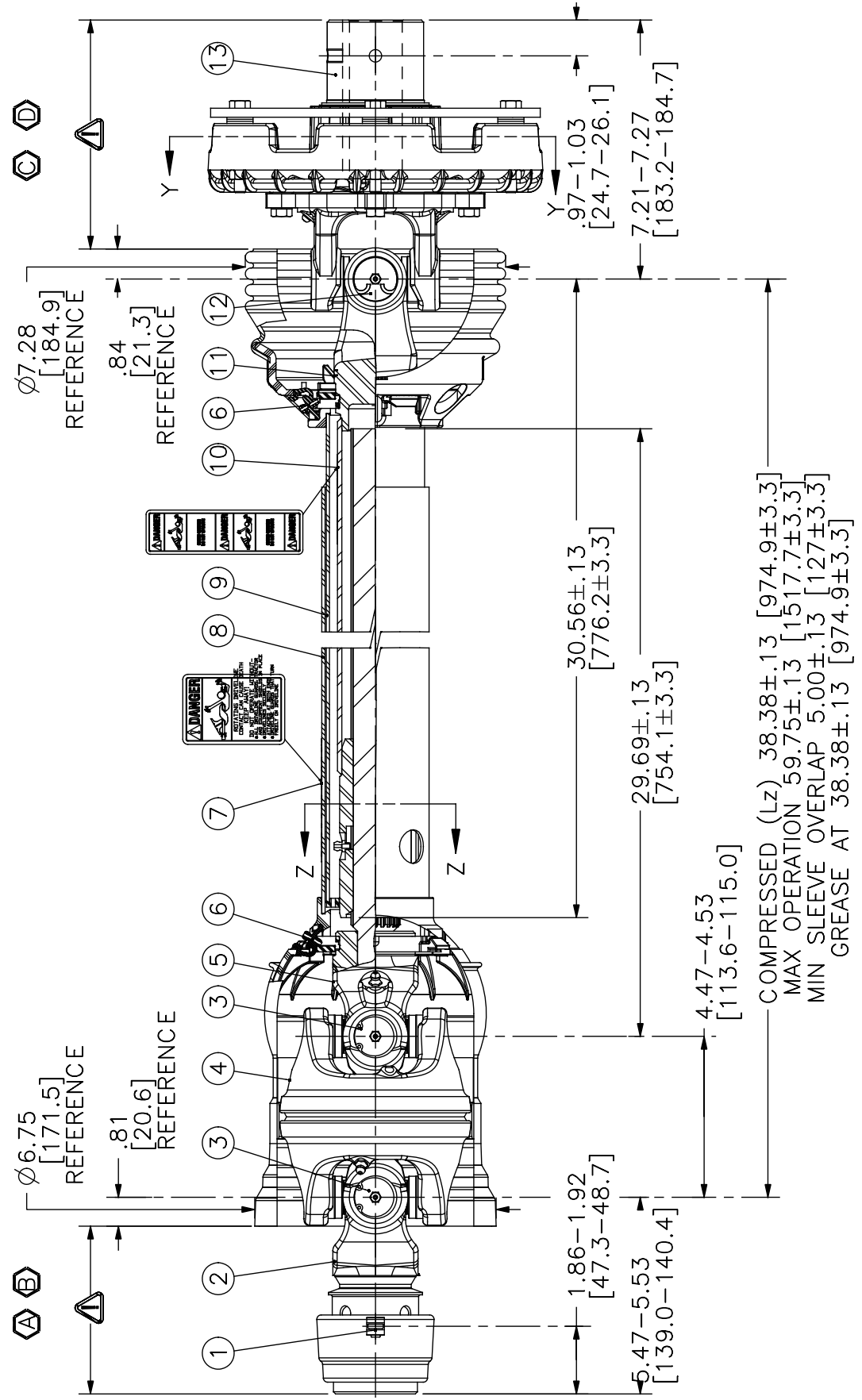

<u>ITEM NO.</u>	<u>PART NUMBER</u>	<u>DESCRIPTION</u>	<u>QTY.</u>
A	H93-26285	JOINT & SHAFT HALF ASM. W/GUARC	1
B	H95-26285	JOINT & SHAFT HALF ASM.	1
C	H92-25415	JOINT & TUBE HALF ASM. W/GUARD	1
D	H94-25415	JOINT & TUBE HALF ASM.	1
1	H26-13387	SSL/AUTO-LOK REPAIR KIT	1
2	H86810-1038	WWCV AUTO-LOK YOKE ASM.	1
3	H03-15436	A86/AW22/CAT 4 80-EBL CROSS KIT	2
4	H26-15159	WWCV CENTER HOUSING	1
5	H99-25415	VWCV YOKE & SHAFT (1.31-20 SPINE)	1
6	H19-15126	GUARD REPAIR KFT	2
7	H13-10021	SAFETT SIGN	1
8	H97-25415	OUTER GUARD	1
9	H96-25415	INNER GUARD	1
10	H13-10022	SAFETT SIGN	1
11	H98-25415	YOKE. TUBE. & SLIP SLEEVE	1
12	H03-15287	35EBL CROSS KIT	1
13	H38-15088	FRICTION CLUTCH ASM.	1



<u>ITEM NO.</u>	<u>PART NUMBER</u>	<u>DESCRIPTION</u>	<u>QTY.</u>
A	NA	JOINT & SHAFT HALF ASM. W/GUARC	1
B	NA	JOINT & SHAFT HALF ASM.	1
C	H92-25415	JOINT & TUBE HALF ASM. W/GUARD	1
D	H94-25415	JOINT & TUBE HALF ASM.	1
1	NA	SSL/AUTO-LOK REPAIR KIT	1
2	NA	WWCV AUTO-LOK YOKE ASM.	1
3	H03-15436	A86/AW22/CAT 4 80-EBL CROSS KIT	2
4	H26-15159	WWCV CENTER HOUSING	1
5	H99-25415	VWCV YOKE & SHAFT (1.31-20 SPINE)	1
6	H19-15126	GUARD REPAIR KFT	2
7	H13-10021	SAFETT SIGN	1
8	H97-25415	OUTER GUARD	1
9	H96-25415	INNER GUARD	1
10	H13-10022	SAFETT SIGN	1
11	H98-25415	YOKE. TUBE. & SLIP SLEEVE	1
12	H03-15287	35EBL CROSS KIT	1
13	H38-15088	FRICTION CLUTCH ASM.	1

MAIN FLOOR ASSEMBLY

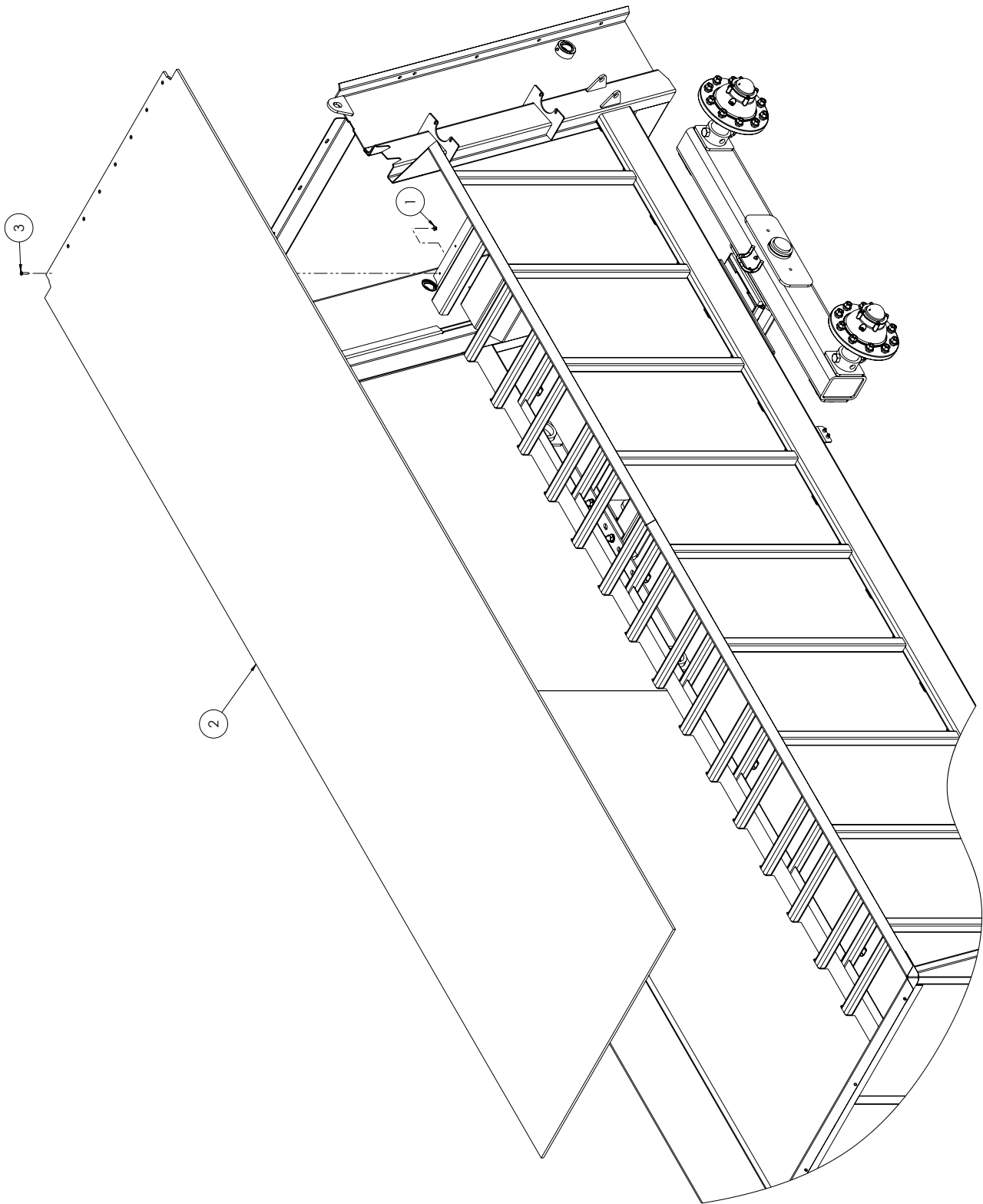

---

<b>ITEM NO.</b>	<b>PART NUMBER</b>	<b>DESCRIPTION</b>	<b>QTY.</b>
1	600110	NUT, HFH NYLOC 5/16-18	8
2	725698	FLOOR, X350	1
3	MP907624	SCREW - FHSCS 5/16-18 X	8

GEARBOX TO BOX ASSEMBLY

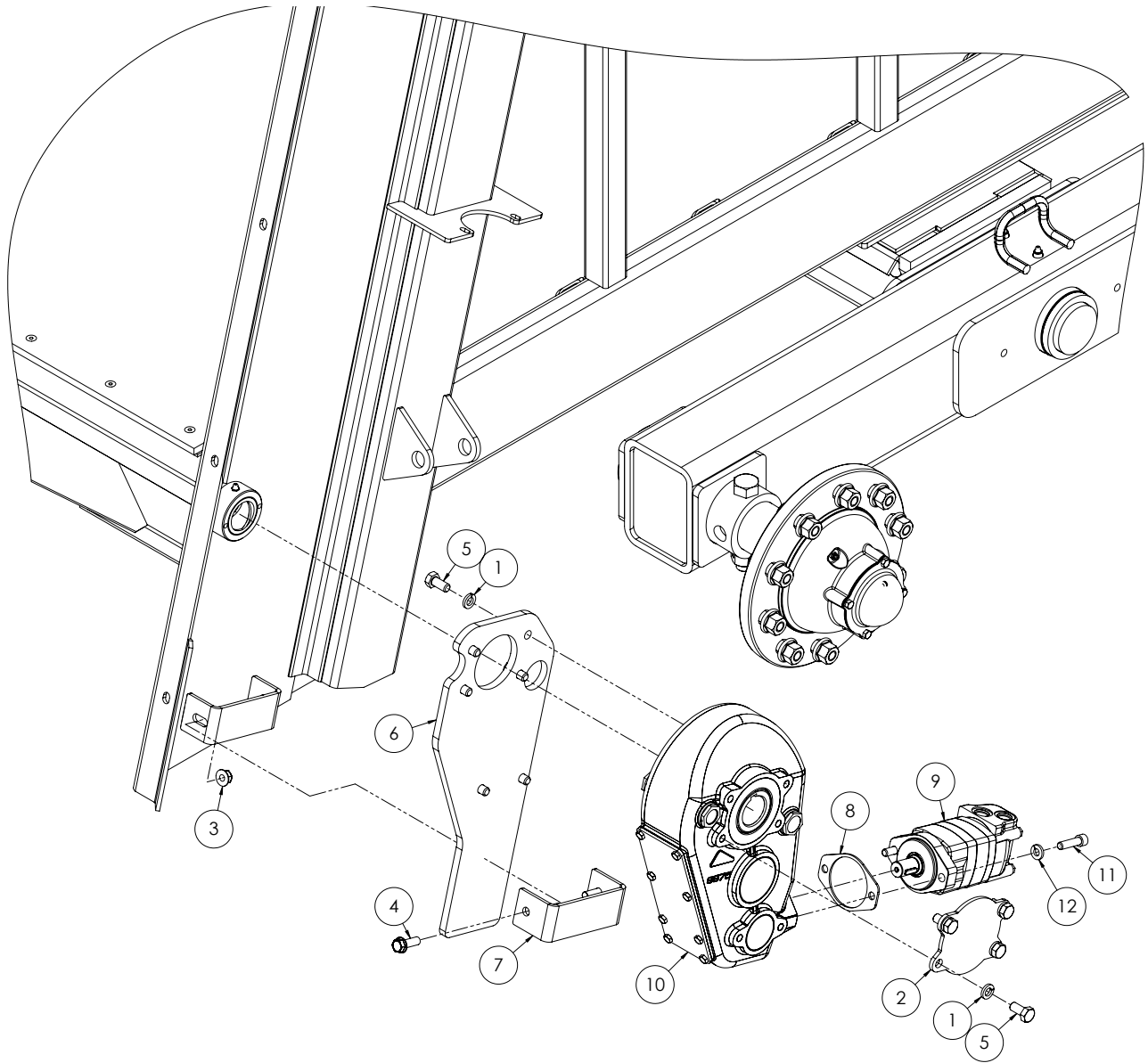



<b>ITEM NO.</b>	<b>PART NUMBER</b>	<b>DESCRIPTION</b>	<b>QTY.</b>
1	020440	WASHER, LOCK 5/8	10
2	598420	END PLATE, GEARBOX	1
3	600140	NUT, HFH NYLOC 1/2-13	2
4	600580	BOLT, HFH 1/2-13	2
5	H4138	BOLT, HHCS M14-2 X 30 GR8.8	10
6	H15560	TORQUE PLATE	1
7	H610131	BRACKET, U	1
8	H610132	MOTOR SHIM PLATE	1
9	HC47-00-3122	MOTOR, HYD	1
10	HO74-01-5069	GEARBOX, RIGHT ANGLE	1
11	HZ86-11-1245	SHCS, M12-1.75 X 45	2
12	MP907700	WASHER, LOCK M12	2

GEARBOX ASSEMBLY

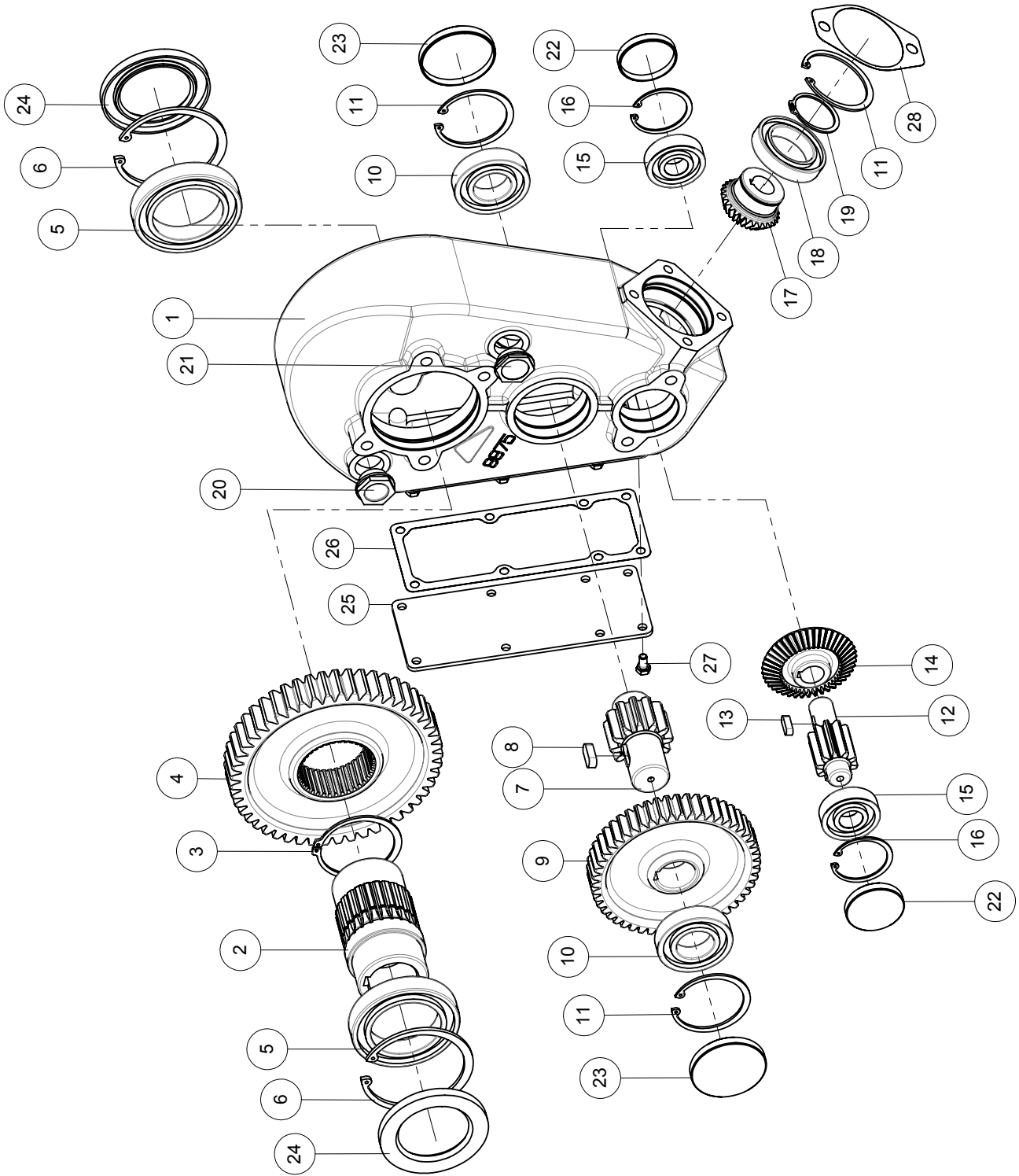

<b>ITEM NO.</b>	<b>PART NUMBER</b>	<b>DESCRIPTION</b>	<b>QTY.</b>
1	H9975	HOUSING RT350	1
2	H14551	HUB Ø2"	1
3	H9918	CIRCLIP E 82	1
4	H9974	GEAR Z=49	1
5	H9982	BEARING 6015	2
6	H9984	CIRCLIP I 115	2
7	H8670-5	PINION Z=12	1
8	H4174	KEY 12X8X30	1
9	H8670-4	GEAR Z=50	1
10	H3342	BEARING 6208	2
11	H3435	CIRCLIP I 80	3
12	H8670-3	PINION Z=10	1
13	H3396	KEY 8X7X25	1
14	H8670-2	GEAR Z=43	1
15	H8596	BEARING 6305	2
16	H3433	CIRCLIP I 62	2
17	H9923	PINION Z=28	1
18	H1538	BEARING 6010	1
19	H3428	CIRCLIP E 50	1
20	H9175	OIL BREATHER PLUG Ø1"GAS	2
21	H1831	OIL LEVEL INDIC. Ø1"GAS	2
22	H8625	PLUG Ø62	2
23	H8243	PLUG Ø80	2
24	H9983	OIL SEAL 75/115/10	2
25	H9976	COVER	1
26	H9977	GASKET	1
27	H3284	SCREW,HEX-HD M8X16	8
28	H610132	GASKET	1

APRON CHAIN AND DRIVE ASSEMBLY

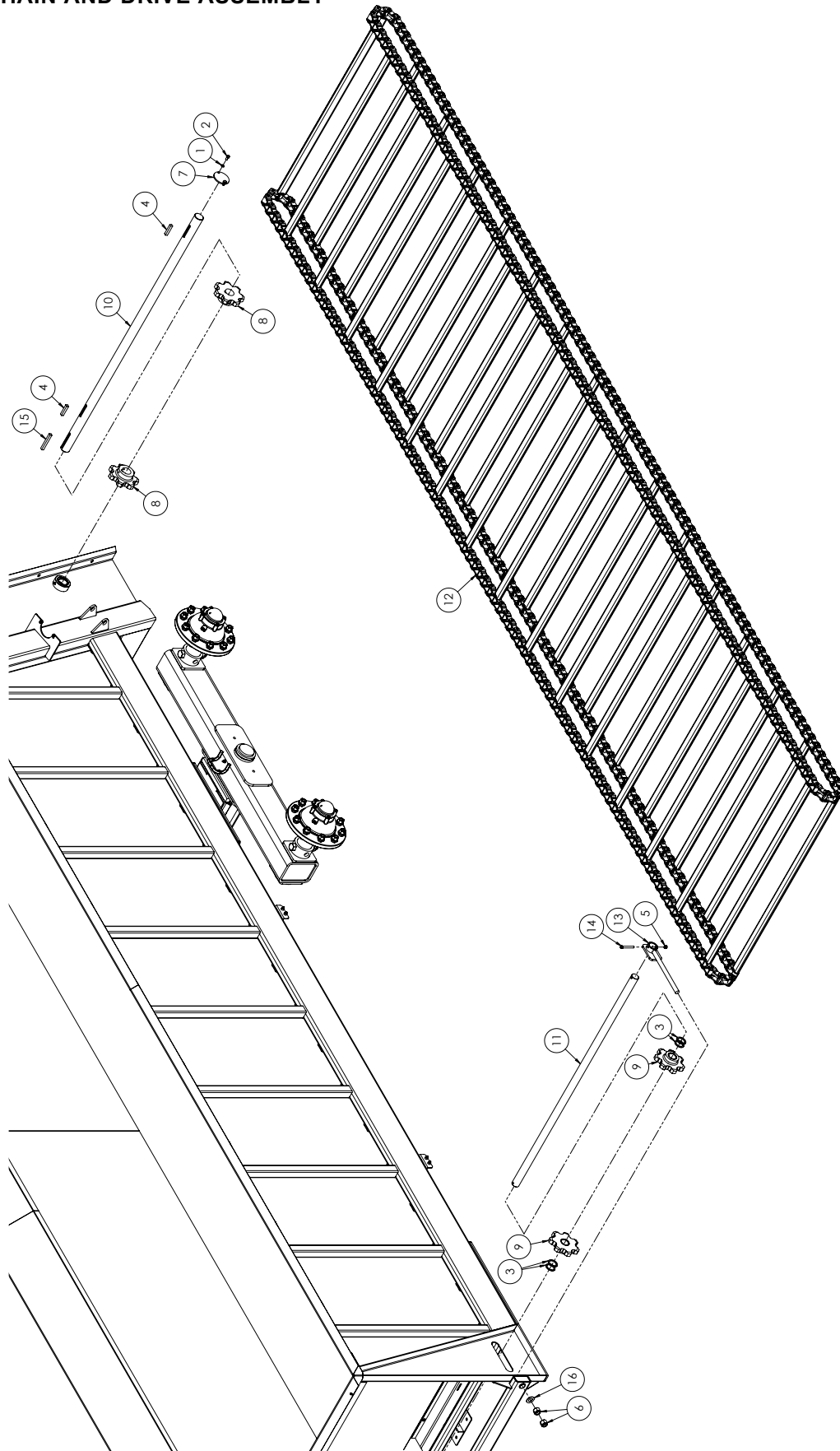

<b>ITEM NO.</b>	<b>PART NUMBER</b>	<b>DESCRIPTION</b>	<b>QTY.</b>
1	021180	WASHER, LOCK 3/8	2
2	022420	BOLT, HHCS 3/8-16 X 3/4"	2
3	041460	WASHER, FLAT 1.62 X 2.12	4
4	042040	KEY, SQUARE 1/2 X 2-3/4	2
5	073630	NUT, LOCK 3/8-16	2
6	600510	NUT, HFH NYLOC 7/8-9	4
7	690665	END CAP, APRON DRIVE	1
8	691720	SPROCKET, 7 TOOTH 88C	2
9	691725	SPROCKET, 7 TOOTH 88C	2
10	725668	SHAFT, DRIVE	1
11	725674	SHAFT, IDLER	1
12	725701	CHAIN WLDT, APRON	1
13	725727	TIGHTENER, OUTSIDE	2
14	990820	BOLT, HHCS 3/8-16 X 3	2
15	P10045	KEY, SQ 1/2"X4-3/8"	1
16	1131018	WASHER, FLAT 7/8 SAE ZN	2
-	397490P	LINK, CONNECTOR 88C (SINGLE)	AR
-	725684	SLAT, APRON CHAIN (WELD-IN)	AR
-	725732	APRON CHAIN WLDT, SERVICE (1 SLAT, 4 LINKS)	AR
CONNECTING LINKS AND COTTER PINS INCLUDED WITH COMPLETE CHAIN. COMPLETE APRON CHAIN NOT ELIGIBLE FOR IMMEDIATE WARRANTY SERVICE.			

SLOP GATE ASSEMBLY

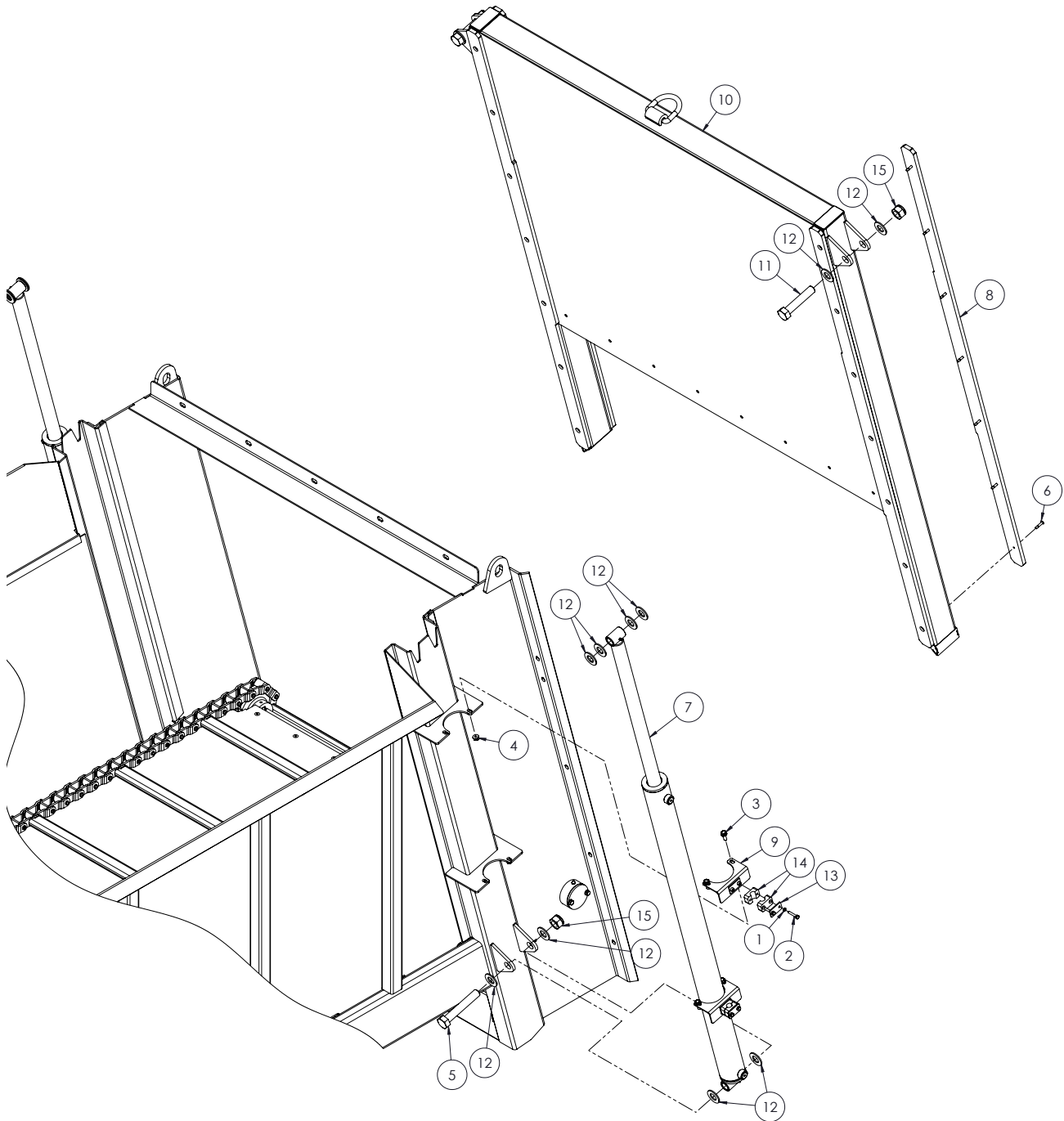

<b>ITEM NO.</b>	<b>PART NUMBER</b>	<b>DESCRIPTION</b>	<b>QTY.</b>
1	029440	WASHER, LOCK 1/4 SAE	8
2	047000	BOLT, HHCS 1/4-20 X 1-1/2	8
3	600050	BOLT, HFH 3/8-16 X 1.00"	8
4	600120	NUT, HFH NYLOC 3/8-16	8
5	600490	BOLT, HHCS 1-8 X 6"	2
6	660570	1/4" BLIND RIVET	28
7	660580	CYLINDER, HYD	2
8	660595	PLASTIC SLIDE,	4
9	690765	CYLINDER HOLDER WLDMNT	4
10	725670	SLOP GATE WELDMENT,	1
11	991060	BOLT, HHCS 1-8 X 5	2
12	1107389	WASHER, FLAT 1 SAE	20
13	HC14-00-3169	TOP CAP, HOSE CLAMP	4
14	HC14-00-3171	SECTION, HOSE CLAMP	8
15	MP09.70791	NYLON INSERT LOCKNUT, 1-8 UNC	4

BEATER TO BOX ASSEMBLY

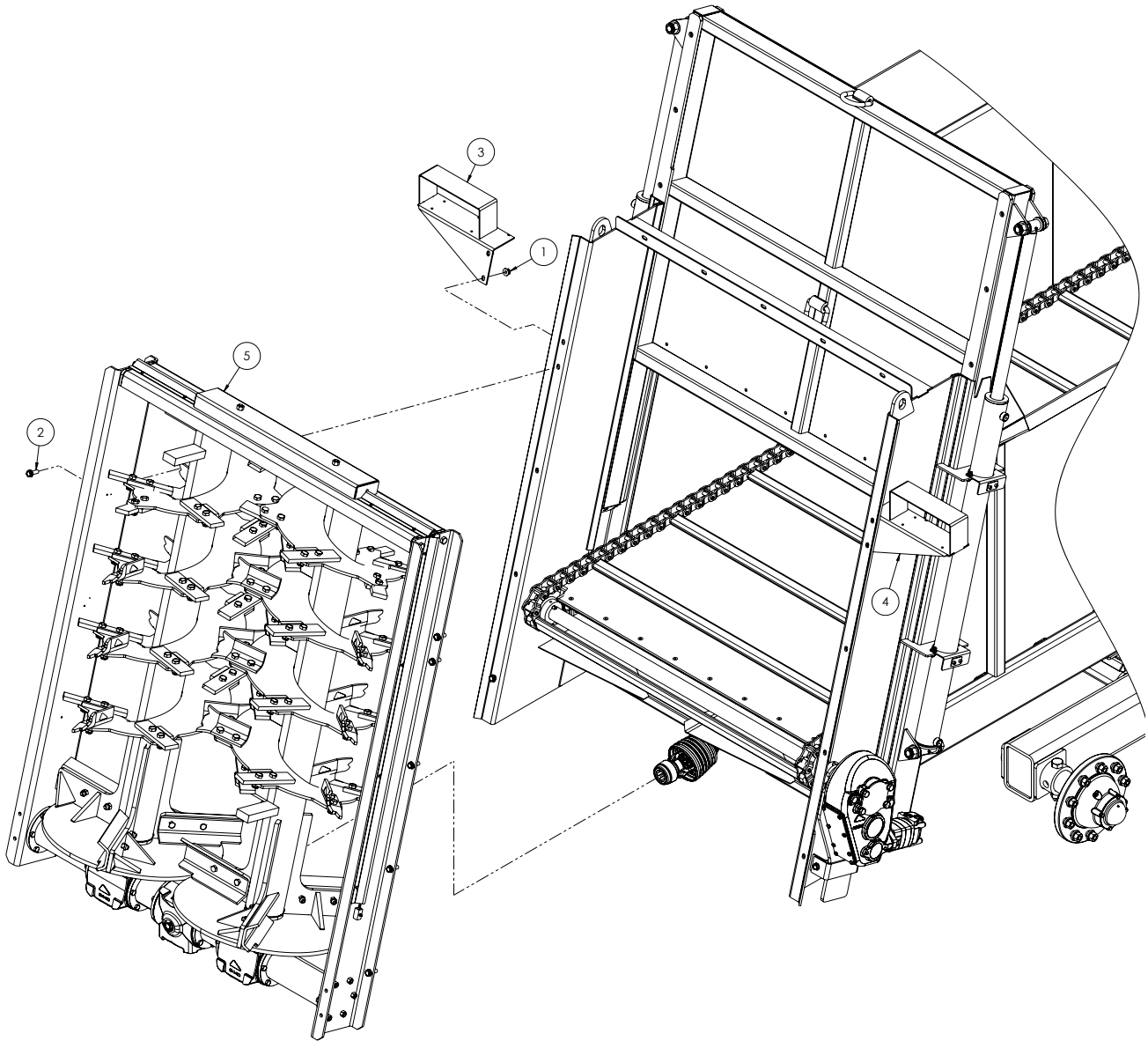



<b>ITEM NO.</b>	<b>PART NUMBER</b>	<b>DESCRIPTION</b>	<b>QTY.</b>
1	600140	NUT, HFH NYLOC 1/2-13	10
2	600580	BOLT, HFH 1/2-13	10
3	725685	MOUNT WLDT,	1
4	725686	MOUNT WLDT,	1
5	725700	BEATERS, SRT8 PAINTED (1000 RPM)	1
	725725	BEATERS, SRT8 PAINTED (540 RPM)	



ITEM NO.	PART NUMBER	DESCRIPTION	QTY.
1	H12148	GEAR BOX SRT8/1500 (1000 RPM)	1
	H16180	GEAR BOX SRT8/1500 (540 RPM)	
2	NA	RIGHT PANEL	NA
3	NA	LEFT PANEL	NA
4	NA	COMPLETE CROSSBAR	NA
5	H18490	RIGHT BEATER	1
6	H18491	LEFT BEATER	1
7	H3768	SCREW,HEX-HD M12X35	12
8	H4478	NUT M12	12
9	H8940	SCREW, HEX-HD M16X35	4
10	H3690	NUT M16	4
11	H7331	OIL SEAL 45/72/10	2
12	H3340	BEARING 1307 E	2
13	H3462	O-RING 176	2
14	H7724	COVERPLATE	2
15	H3435	CIRCLIP I 80	2
16	H1799	NUT M14	6
17	H15618	COVER	NA
18	NA	THREADED BAR M14X80	NA
19	H21097	PROTECTON SHORT	2
20	H3283	SCREW, HEX-HD M8X16	12
21	H18497	PROTECTION LONG	2
22	H21098	LUBRIFICATION KIT Ø6	1
23	H18494	RIGHT SCOOP	3
24	NA	SCREW, HEX-HD M14X1.50X50	NA
25	NA	NUT M14X1.5	NA
26	H9113	NUT M16X1.5	96
27	H22221	KNIFE	30
28	H9802	SCREW, HEX-HD M16X1.5X45	60
29	621252	RIGHT TOOTH	9
30	H18495	LEFT SCOOP	3
31	621251	LEFT TOOTH	9
32	H14054	SCREW, HEX-HD M16X1.5X40	36
33	NA	REINFORCEMENT	30
<b>SEE BEATER MAINTENANCE [PG. 23] FOR ADDITIONAL INFORMATION</b>			

GEARBOX ASSEMBLY (H12148) (1000 RPM ONLY)

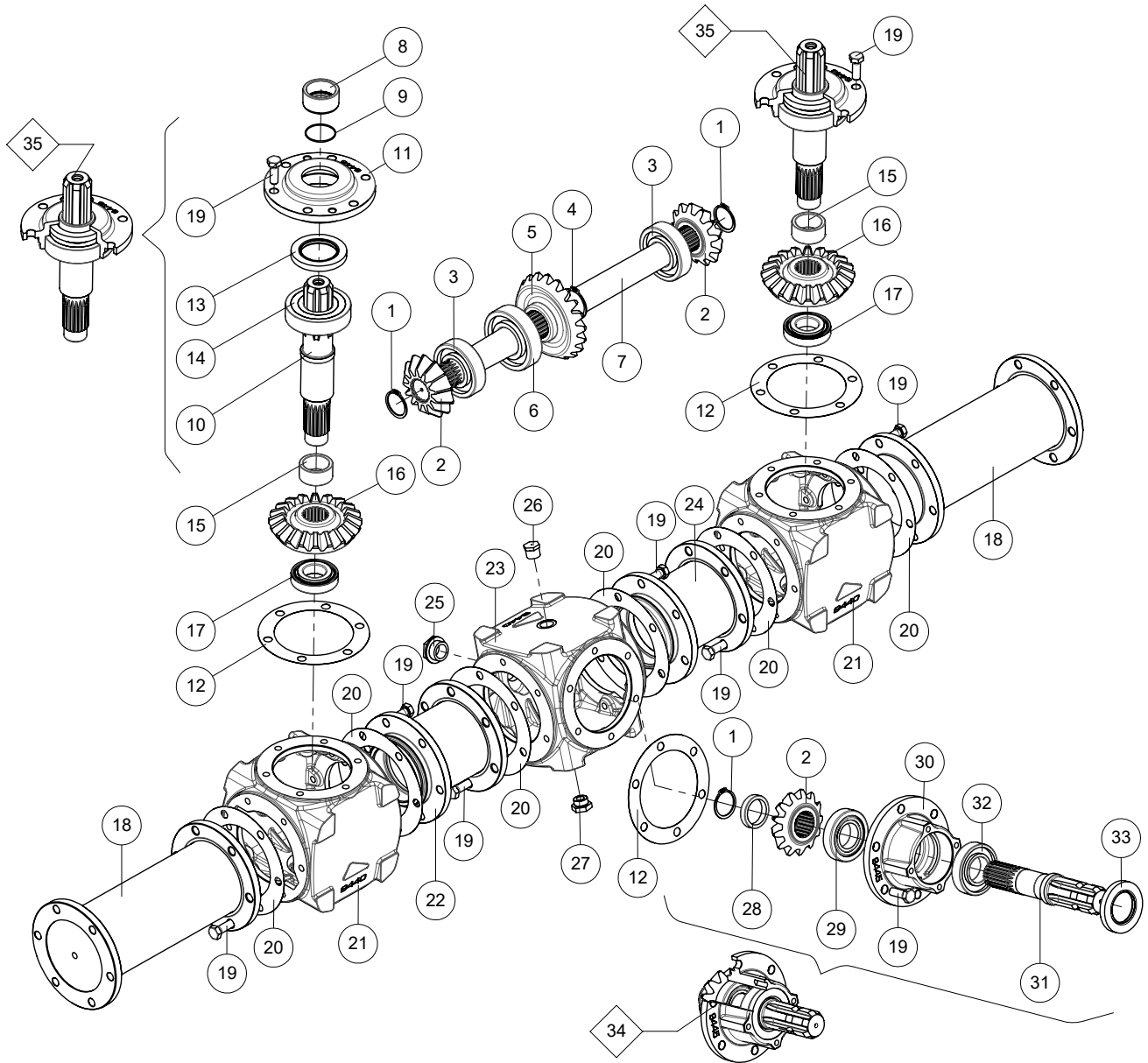

<u>ITEM NO.</u>	<u>PART NUMBER</u>	<u>DESCRIPTION</u>	<u>QTY.</u>
1	H3426	CIRCLIP E40	3
2	H9476	PINION Z=13	3
3	H19412	BEARING 6308-QLT	2
4	H3427	CIRCLIP E45	1
5	H9502	GEAR Z=20	1
6	H19413	BEARING 6309-QLT	1
7	H9522	SHAFT L=612	1
8	H9524	SPACER	2
9	H9926	O-RING 2175	2
10	H9507	SHAFT	2
11	H9446	CALOTTE	2
12	H9536	GASKET	3
13	H7480	OIL SEAL 55/85/10-DL	2
14	H13102	BEARING 6309-2RS	2
15	H9516	SPACER	2
16	H9477	GEAR Z=20	2
17	H3354	BEARING 30207	2
18	H9523	SPACER L=315	2
19	H3768	SCREW, HEX-HD M12X35	54
20	H9525	GASKET	6
21	H9441	HOUSING	2
22	H9443	RIGHT SPACER L=135	1
23	H9440	HOUSING	1
24	H9444	LEFT SPACER L=135	1
25	H9179	OIL LEVEL INDIC. Ø1" GAS ALL.	1
26	H9706	OIL BREATHER PLUG Ø1/2" GAS	1
27	H9707	OIL PLUG Ø1/2" GAS	1
28	H12629	SPACER	1
29	H4910	BEARING 30208	1
30	H9445	HUB	1
31	H9509	SHAFT	1
32	H3342	BEARING 6208	1
33	H9537	OIL SEAL 48/80/10-DL	1
34	H12150	COMPLETE HUB	1
35	H9539	COMPLETE CALOTTE	2
<b>SEE BEATER MAINTENANCE [PG. 23] FOR ADDITIONAL INFORMATION</b>			

GEARBOX ASSEMBLY (H16180) (540 RPM ONLY)

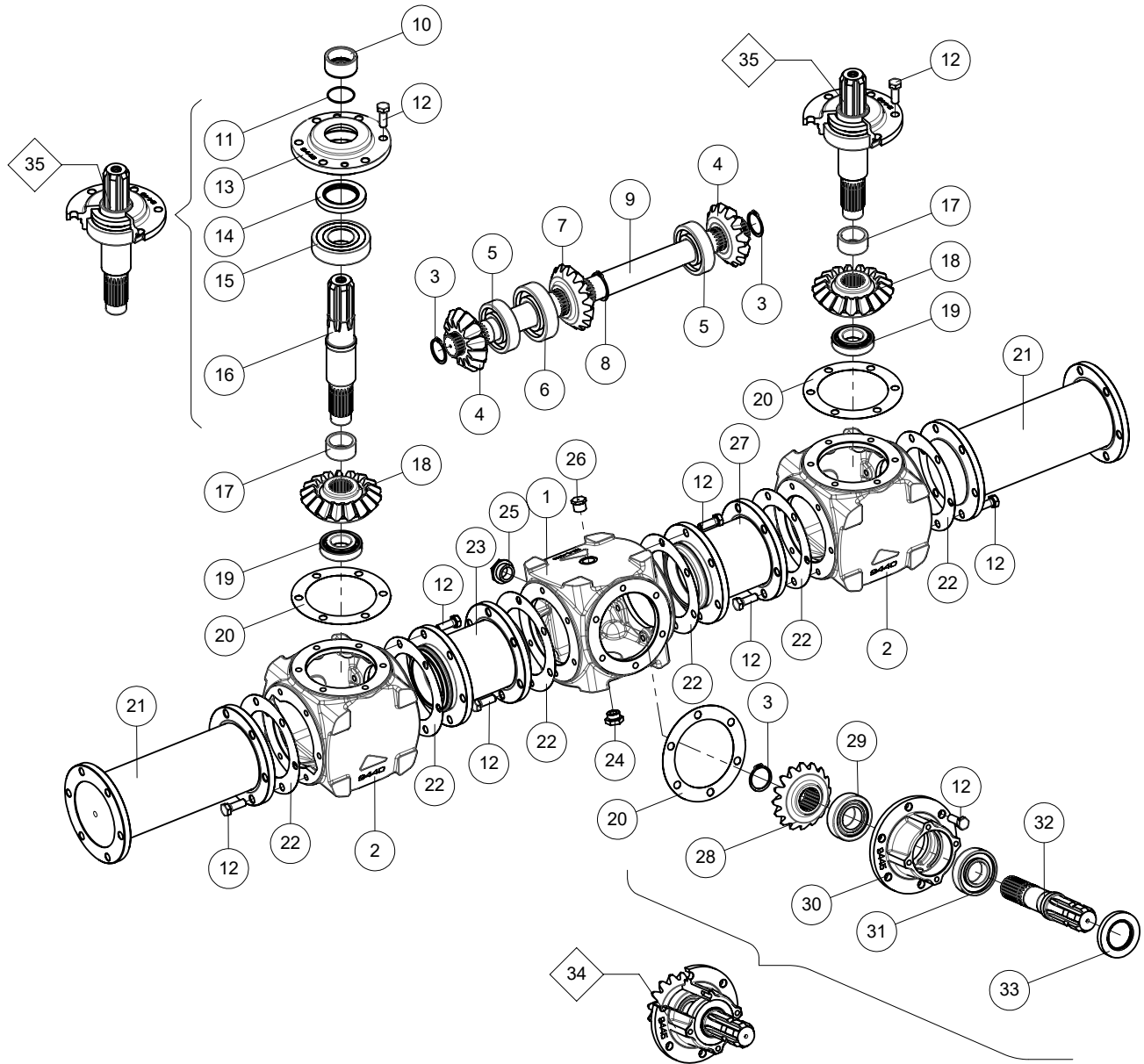

<u>ITEM NO.</u>	<u>PART NUMBER</u>	<u>DESCRIPTION</u>	<u>QTY.</u>
1	H9440	HOUSING	1
2	H9441	HOUSING	2
3	H3426	CIRCLIP E40	3
4	H12041	BEVEL PINION Z=14	2
5	H19412	BEARING 6308-QLT	2
6	H19413	BEARING 6309-QLT	1
7	H9501	BEVEL PINION Z=16	1
8	H3427	CIRCLIP E45	1
9	H9522	SHAFT L=612	1
10	H9524	SPACER	2
11	H9926	O-RING 2175	2
12	H3768	SCREW, HEX-HD M12X35	54
13	H9446	CALOTTE	2
14	H7480	OIL SEAL 55/85/10-DL	2
15	H13102	BEARING 6309-2RS	2
16	H9507	SHAFT	2
17	H9516	SPACER	2
18	H12042	GEAR Z=18	2
19	H3354	BEARING 30207	2
20	H9536	GASKET	3
21	H9523	SPACER L=315	2
22	H9525	GASKET	6
23	H9443	RIGHT SPACER L=135	1
24	H9707	OIL PLUG Ø1/2" GAS	1
25	H9179	OIL LEVEL INDIC. Ø1" GAS ALL.	1
26	H9706	OIL BREATHER PLUG Ø1/2" GAS	1
27	H9444	LEFT SPACER L=135	1
28	H9500	PINION Z=16	1
29	H9013	BEARING 32208	1
30	H9445	HUB	1
31	H3342	BEARING 6208	1
32	H9509	SHAFT	1
33	H9537	OIL SEAL 48/80/10-DL	1
34	H9538	COMPLETE HUB	1
35	H9539	COMPLETE CALOTTE	2
<b>SEE BEATER MAINTENANCE [PG. 23] FOR ADDITIONAL INFORMATION</b>			

ROCK GUARD ASSEMBLY

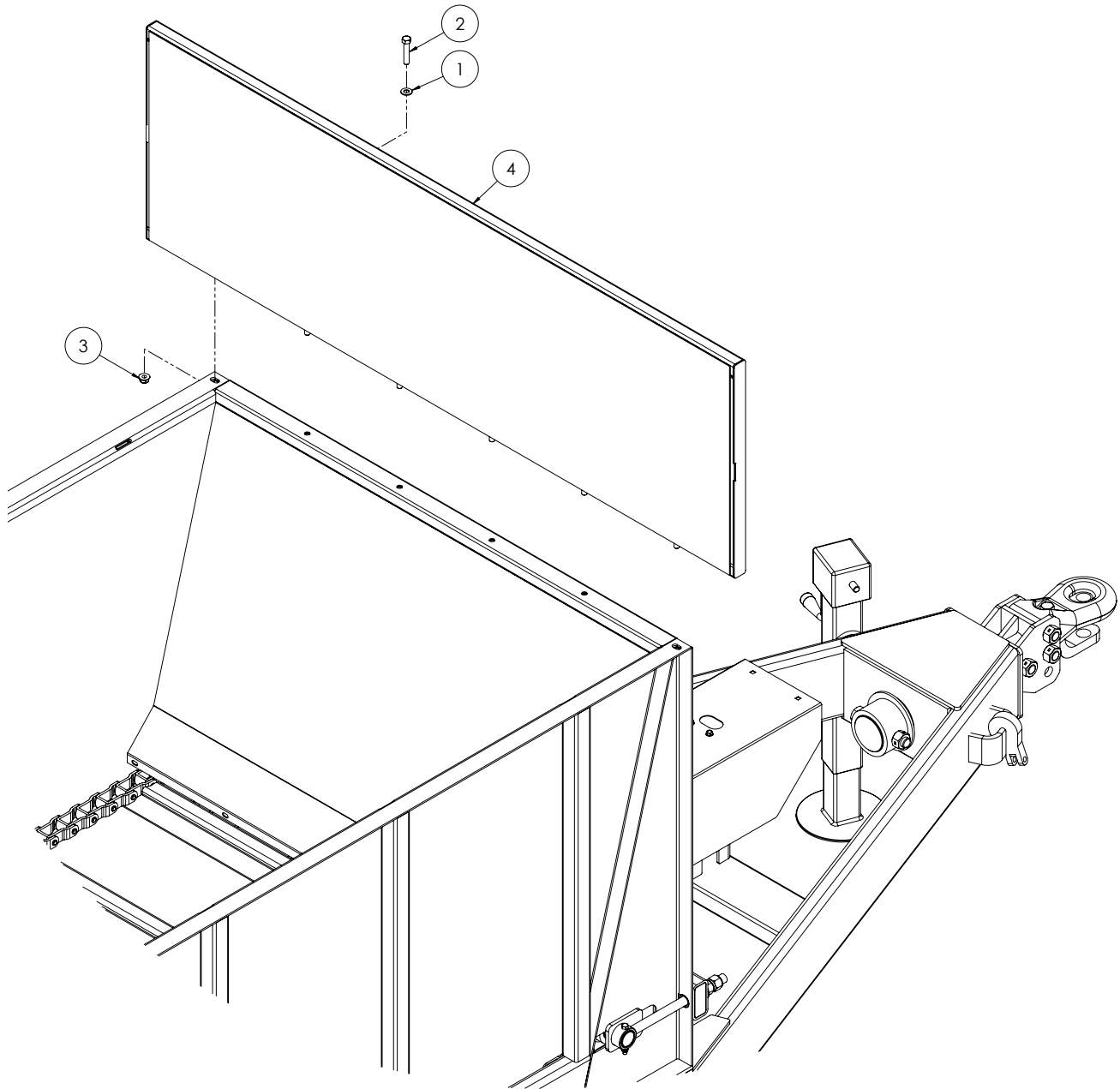



---

<u>ITEM NO.</u>	<u>PART NUMBER</u>	<u>DESCRIPTION</u>	<u>QTY.</u>
1	005200	WASHER, FLAT 1/2 STD	12
2	007080	BOLT, HHCS 1/2-13 X 2-1/2	6
3	600140	NUT, HFH NYLOC 1/2-13	6
4	725704	GUARD WLDT, ROCK	1

HYDRAULIC COMPONENT ASSEMBLY

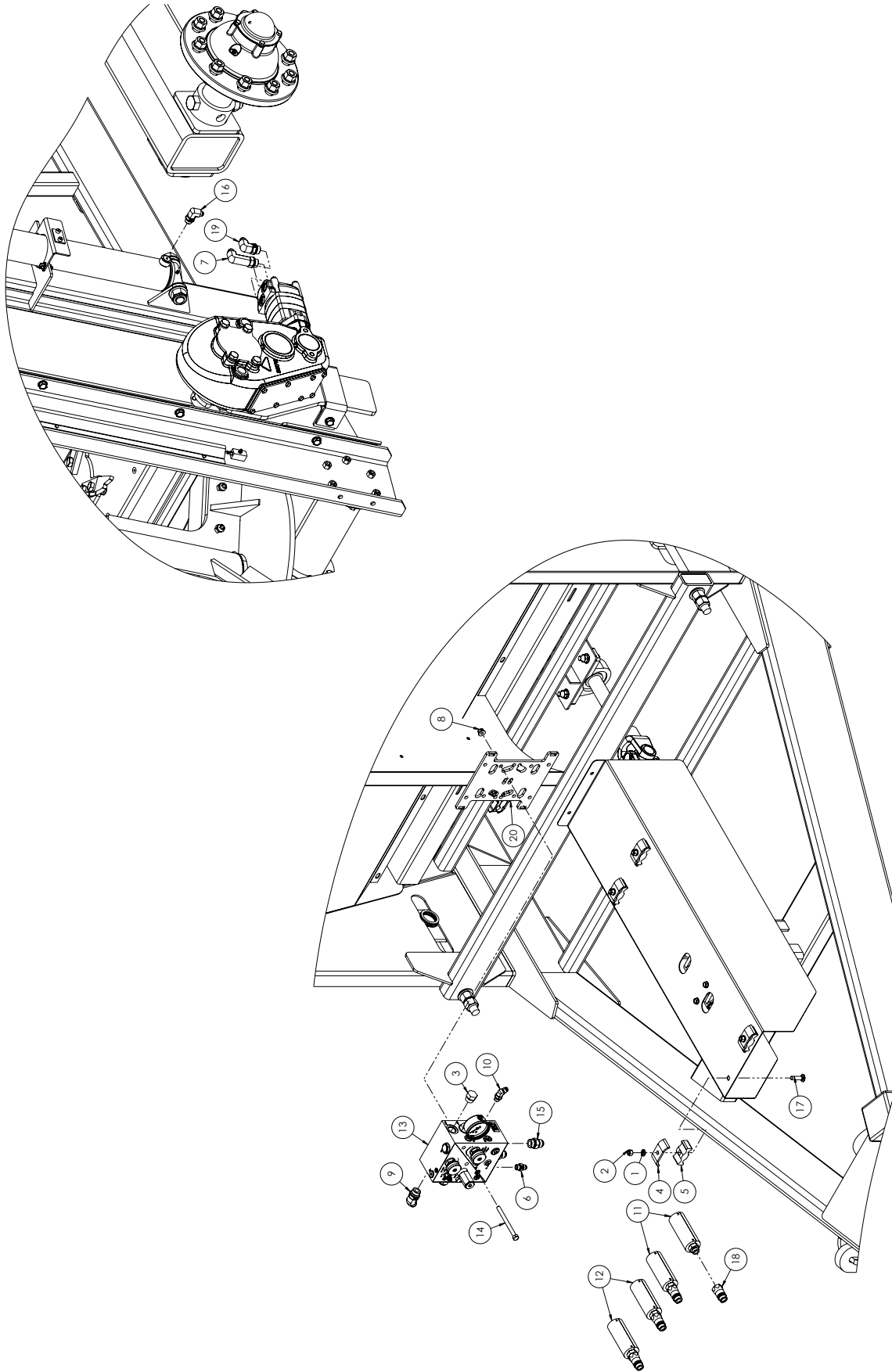

<b>ITEM NO.</b>	<b>PART NUMBER</b>	<b>DESCRIPTION</b>	<b>QTY.</b>
1	021180	WASHER, LOCK 3/8	12
2	027260	NUT, HEX 3/8-16 GR5	12
3	274420	FITTING, HYD PLUG	2
4	527680	BAR, HOSE CLAMP	12
5	527700	CLAMP, HOSE	16
6	530240	FITTING, HYD STRAIGHT	2
7	594840	FITTING, HYD 90 LL	1
8	600120	NUT, HFH NYLOC 3/8-16	2
9	626825	FITTING, HYD 45°	2
10	634103	FITTING, HYD 45	2
11	690610	FITTING, HYD GRIP BLACK	1
12	690611	FITTING, HYD GRIP BLACK	1
13	690880	BLOCK, HYD F13890A1	1
14	991160	BOLT, HHCS 3/8-16 X 4"	2
15	I2185062	FITTING, HYD STRAIGHT	2
16	I2185128	FITTING, HYD 90°	4
17	J03H1558	BOLT, CRG 3/8-16 X 1-1/2	8
18	MP09.74158	COUPLER, QUICK MALE	4
19	MP32.03794	FITTING, HYD 90	1
20	V061812	BOLT, CRG, 3/8-16 X 2.50 GR5 ZN	4

**GREASE ASSEMBLY**

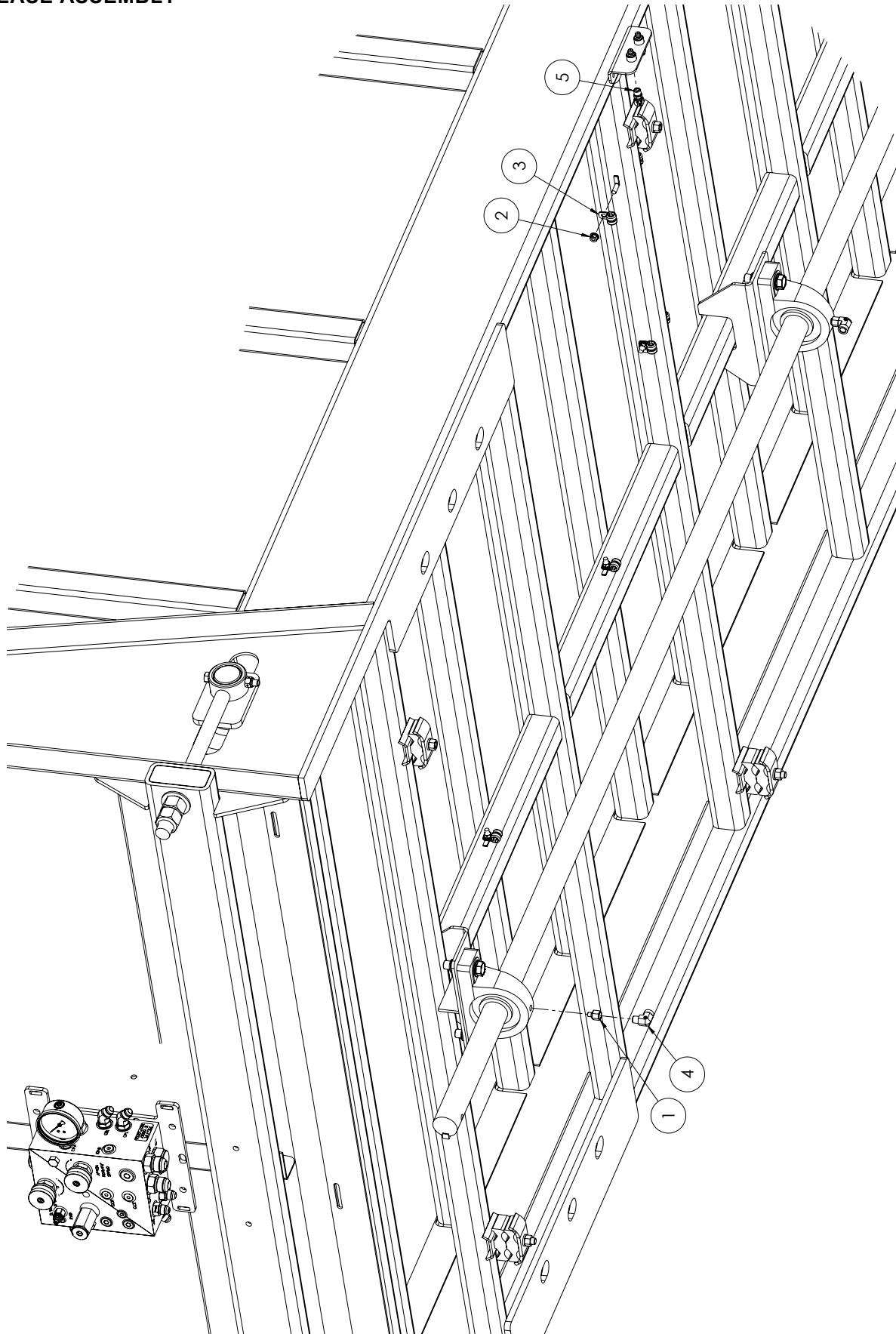

<b>ITEM NO.</b>	<b>PART NUMBER</b>	<b>DESCRIPTION</b>	<b>QTY.</b>
1	244270	ADAPTER, STRAIGHT	3
2	600100	NUT, HFH NYLOC 1/4-20	9
3	HJ14-00-0142	CLAMP, 1/4"	9
4	HT78-26-0204	ELBOW, BRASS 90°	3
5	HT78-47-0204	STRAIGHT, BRASS, 1/8 M	3
-	HJ40-01-0079	GREASE LINE, PREFILLED (SOLD PER FOOT)	AR

LIGHTS ASSEMBLY

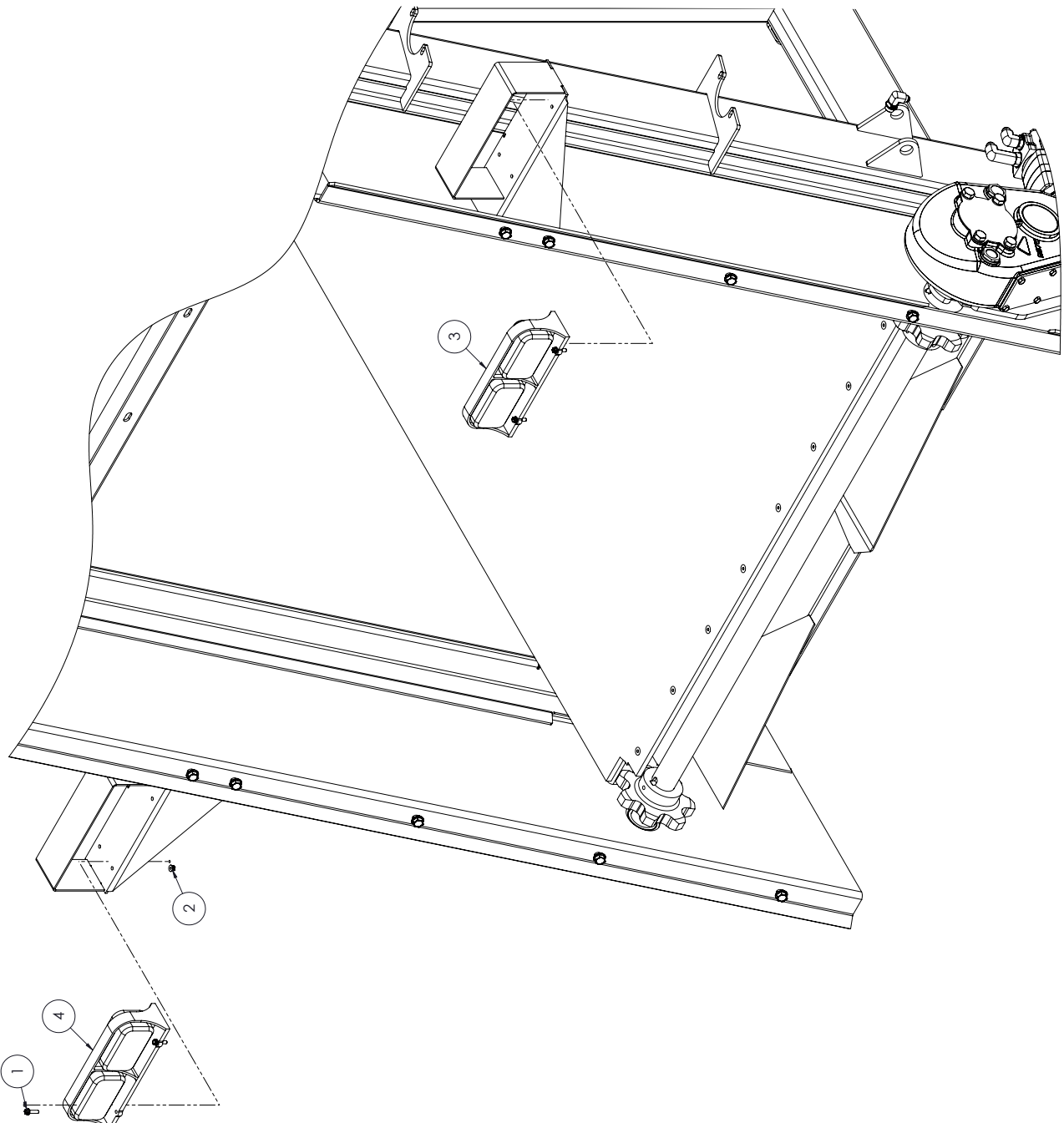
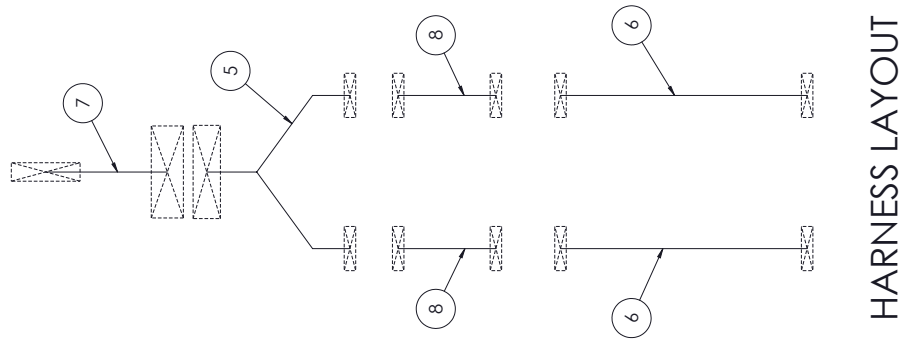

<b>ITEM NO.</b>	<b>PART NUMBER</b>	<b>DESCRIPTION</b>	<b>QTY.</b>
1	600020	BOLT, HFH 1/4-20 X 1.00"	8
2	600100	NUT, HFH NYLOC 1/4-20	8
3	642580	LIGHT, LED	1
4	642590	LIGHT, LED	1
5	642600	HARNESS, Y-SPLITTER	1
6	642610	HARNESS, 20' LIGHT	2
7	642620	HARNESS, MAIN LIGHT	1
8	642640	HARNESS, 3' EXTENSION	2

MANUAL ASSEMBLY

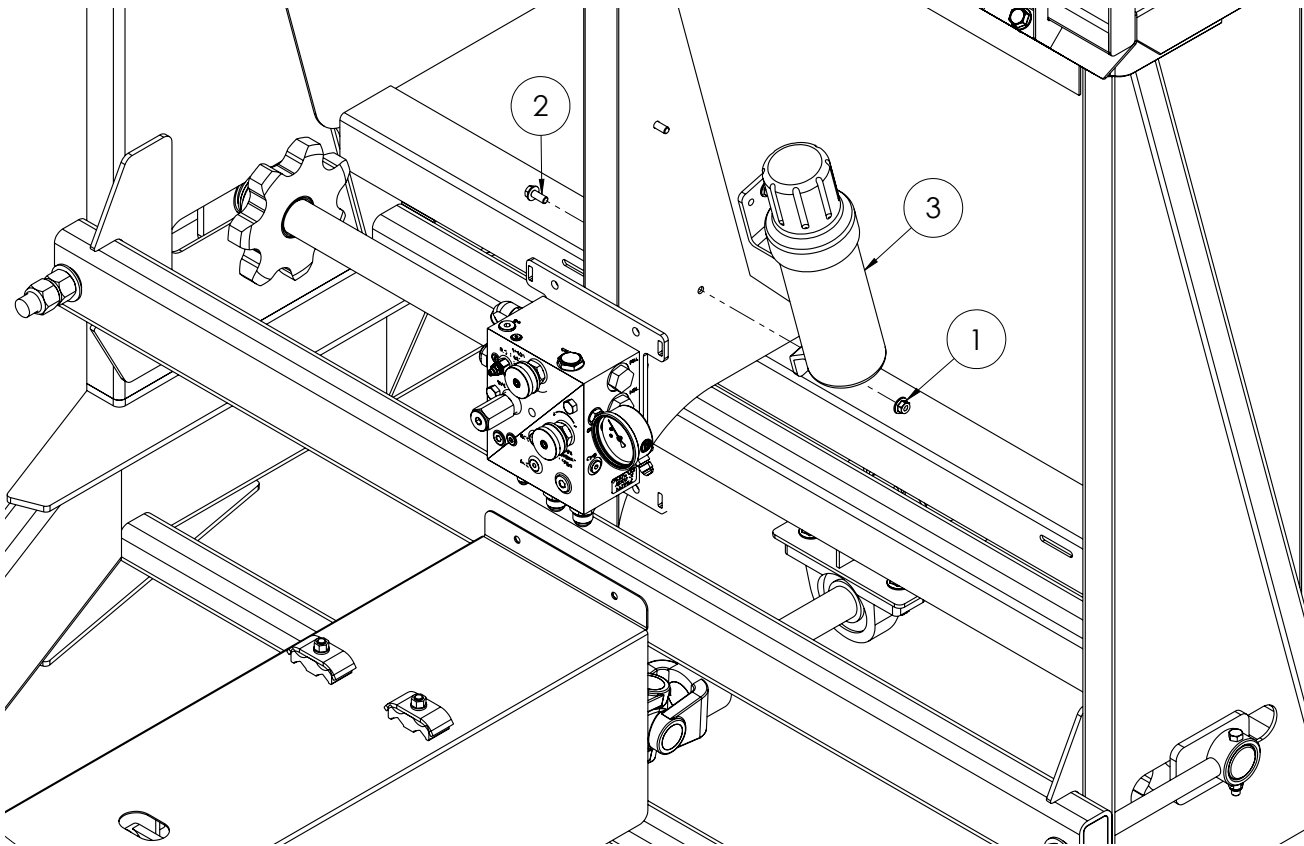



---

<b>ITEM NO.</b>	<b>PART NUMBER</b>	<b>DESCRIPTION</b>	<b>QTY.</b>
1	600110	NUT, HFH NYLOC 5/16-18	2
2	JN10212	SCREW, FLG 5/16-18 X 3/4	2
3	MP907739	TUBE - OP MAN HOLDER	1

FLASHING ASSEMBLY

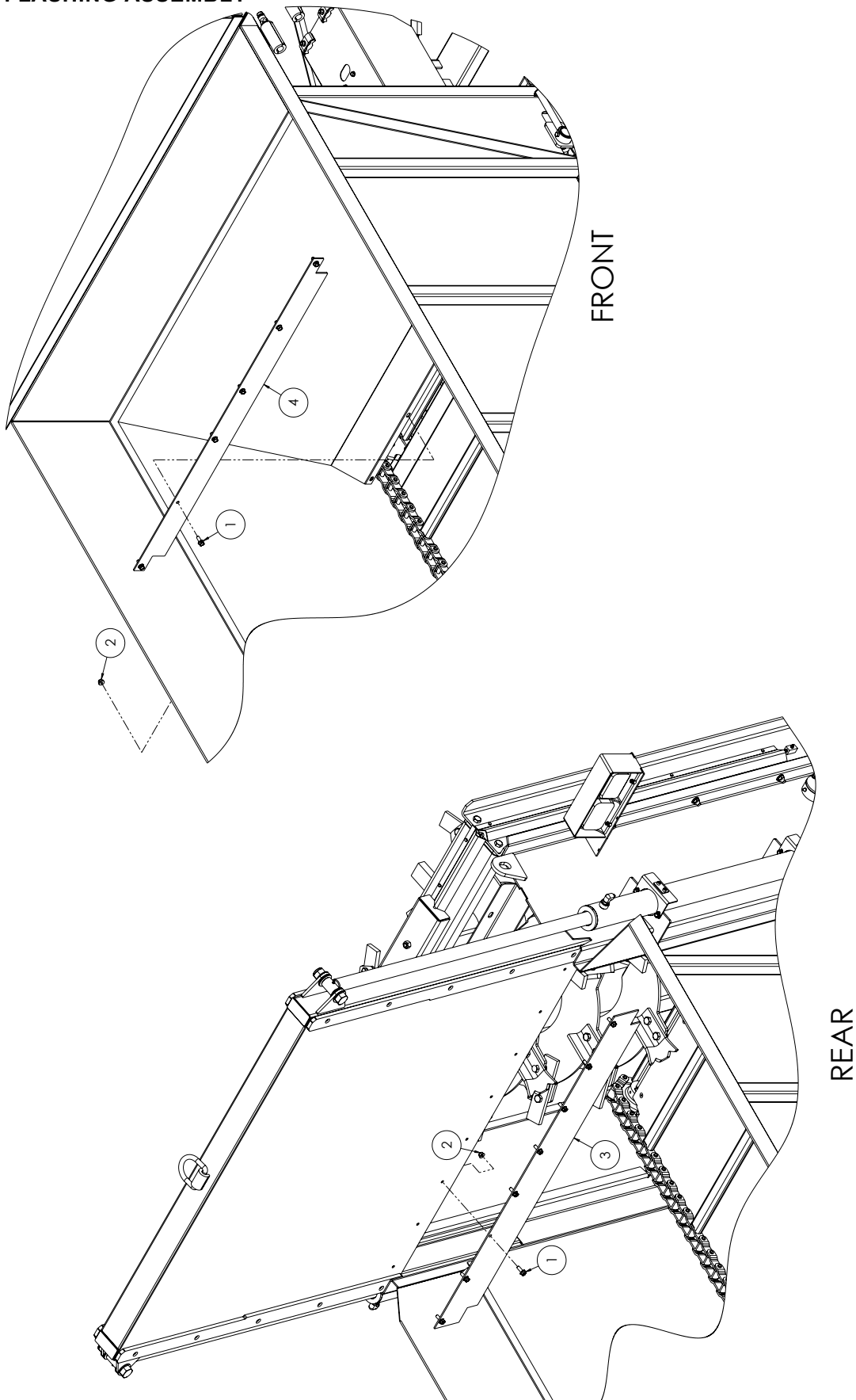

---

<u>ITEM NO.</u>	<u>PART NUMBER</u>	<u>DESCRIPTION</u>	<u>QTY.</u>
1	600050	BOLT, HFH 3/8-16 X 1.00"	14
2	600120	NUT, HFH NYLOC 3/8-16	14
3	725691	STRIP, SLOP GATE	1
4	725692	STRIP, FRONT SEAL	1

DECAL PLACEMENT

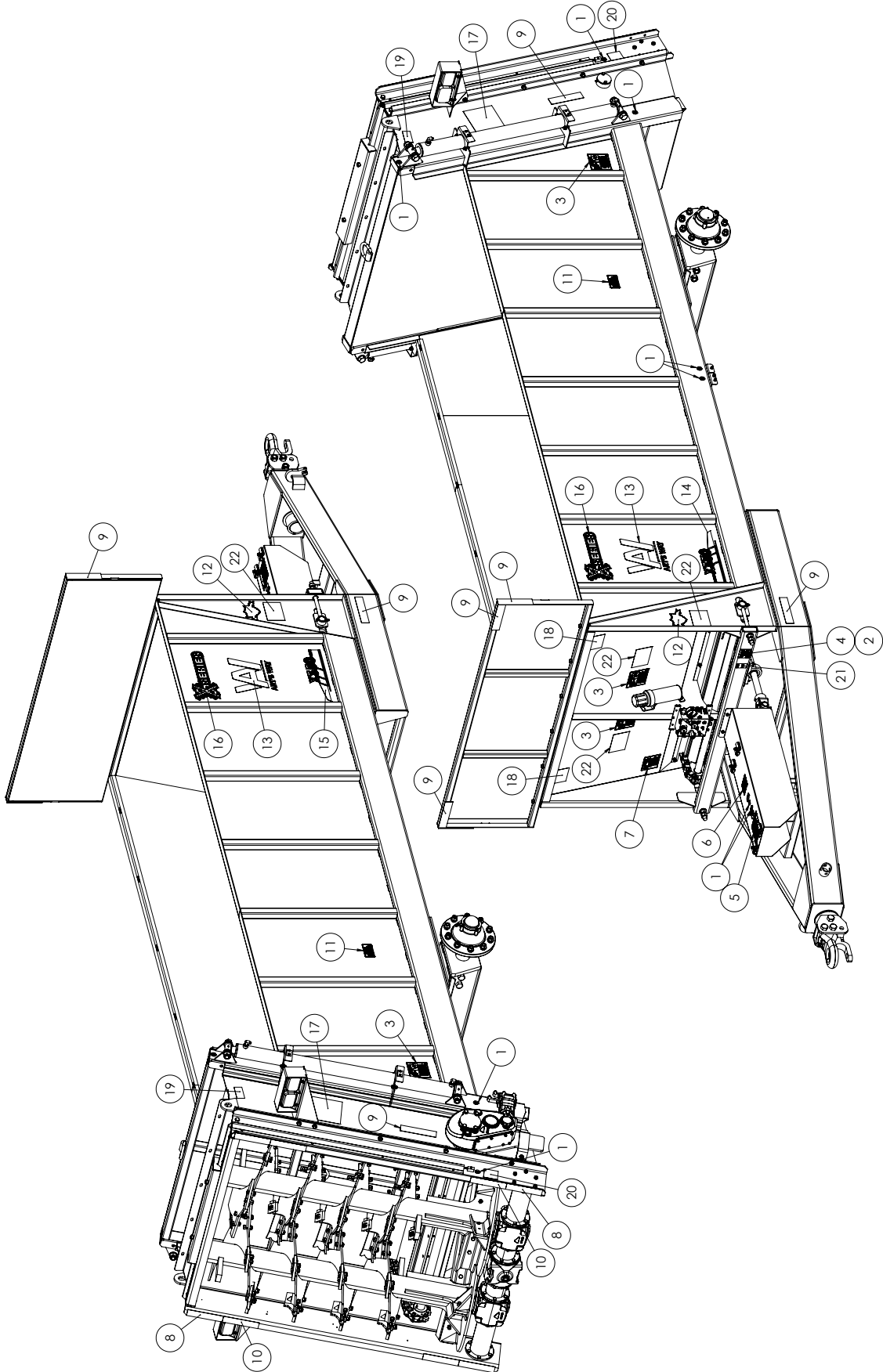

<u>ITEM NO.</u>	<u>PART NUMBER</u>	<u>DESCRIPTION</u>	<u>QTY.</u>
1	146670	DECAL, GREASE SYMBOL	10
2	204510	NAIL, 1/4 GRIP	4
3	346310	DECAL, WARNING HIGH PRESSURE	4
4	355600	TAG, SERIAL NUMBER	1
5	368040	DECAL, WARNING MOVING PART	1
6	384020	DECAL, DANGER 1050 RPM	1
7	467450	DECAL, WARNING	2
8	476450	TAPE, RED RETROREFLECTIVE	4
9	476460	TAPE, YELLOW RETROREFLECTIVE	8
10	476470	TAPE, RED-ORANGE FLORESCENT	4
11	597390	DECAL, IMPORTANT	2
12	608085	DECAL, MADE IN AMERICA	2
13	720110	DECAL, NEW ARTS WAY LOGO	2
14	720627	DECAL, X350 LEFT	1
15	720628	DECAL, X350 RIGHT	1
16	720830	DECAL, "X" SERIES	2
17	HJ22-00-0080	DECAL, DANGER	2
18	HJ22-00-0091	DECAL, THROWN	2
19	HJ22-00-0113	DECAL, HYDRAULIC	2
20	HJ22-00-0114	DECAL, ROTATING	2
21	K18534203	DECAL, FEMA	1
22	MP16.20178	DECAL, WARNING	4

UNIFIED HYDRAULICS

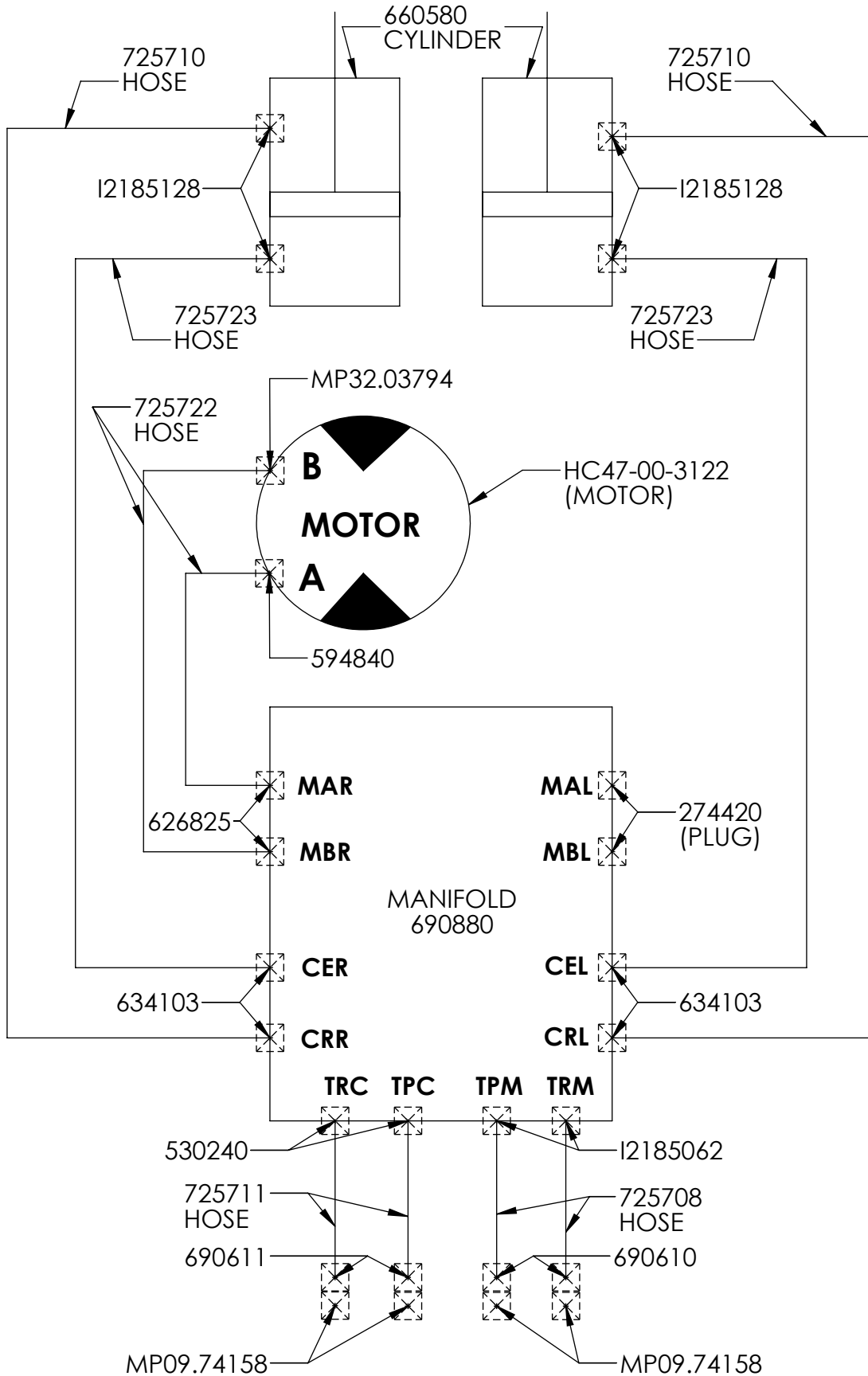

IDENTIFICATION KEY	
LABEL	MEANING
OR	ORIFICE
CV1	CHECK VALVE 1
CV2	CHECK VALVE 2
MAR	MOTOR "A" RIGHT
MBR	MOTOR "B" RIGHT
MAL	MOTOR "A" LEFT
MBL	MOTOR "B" LEFT
CRR	CYLINDER RETRACT RIGHT
CER	CYLINDER EXTEND RIGHT
CRL	CYLINDER RETRACT LEFT
CEL	CYLINDER EXTEND LEFT
PCR	PILOT CHECK RETRACT
PCE	PILOT CHECK EXTEND
GCE	GAUGE CYLINDER EXTEND
GCR	GAUGE CYLINDER RETRACT
GMA	GAUGE MOTOR "A"
GMB	GAUGE MOTOR "B"
TRC	TRACTOR RETURN CYLINDER
TPC	TRACTOR PRESSURE CYLINDER
TPM	TRACTOR PRESSURE MOTOR
TRM	TRACTOR RETURN MOTOR
UL	UNLOADER
RVR	RELIEF VALVE RETRACT
RVD	RELIEF VALVE DISCHARGE
FD	FLOW DIVIDER

UNIFIED HYDRAULIC MANIFOLD

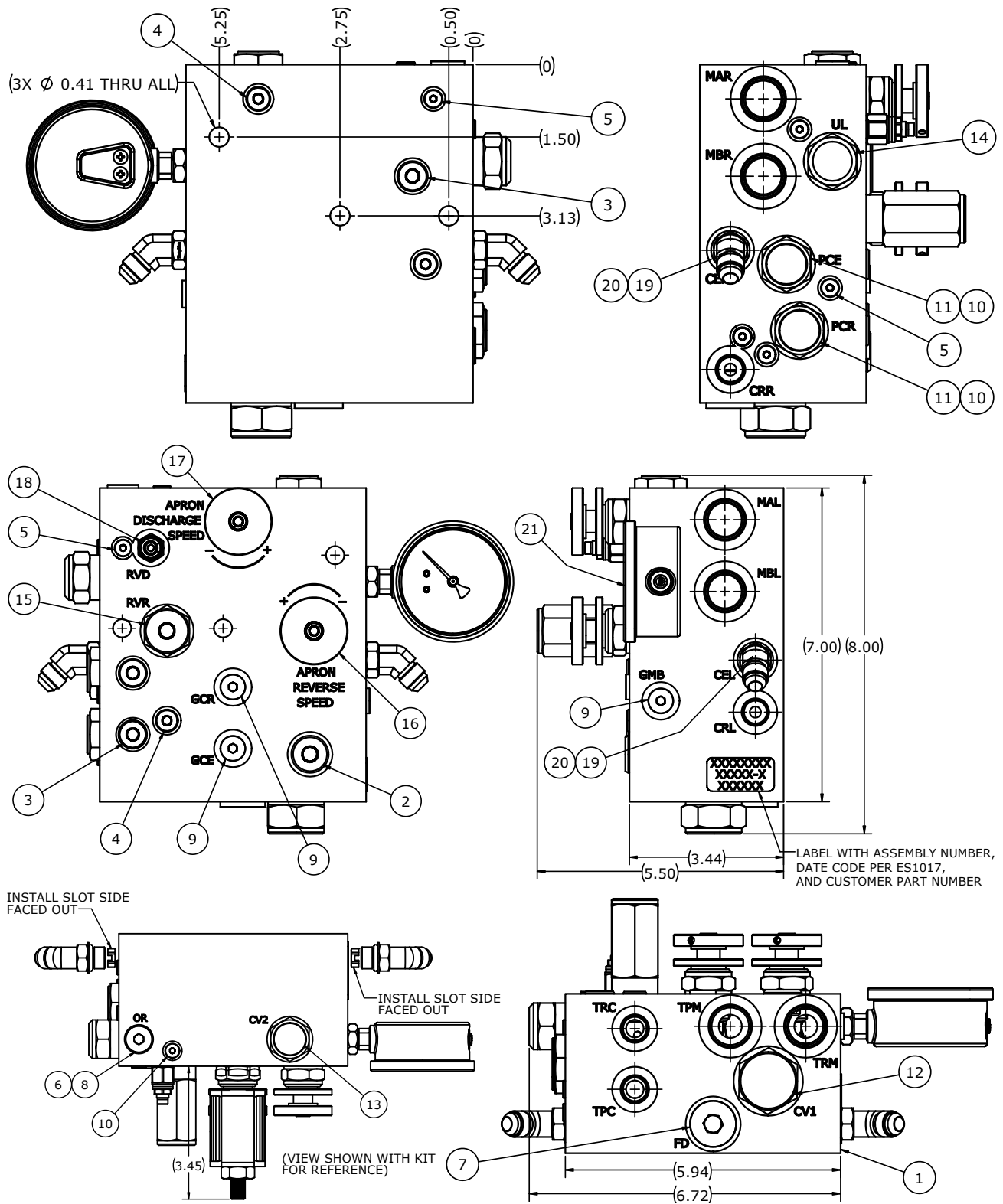



<u>ITEM NO.</u>	<u>PART NUMBER</u>	<u>DESCRIPTION</u>	<u>QTY.</u>
1	N/A	BODY, X-SERIES MANURE SPREADER MFLD	1
2	691250	SAE-8 PLUG ZERO-LEAK	1
3	710834	SAE-6 PLUG, ZERO-LEAK	3
4	691251	SAE-4 PLUG, ZERO-LEAK	3
5	691252	SAE-2 PLUG, ZERO-LEAK	7
6	710820	ORIFICE PLUG 5/16-24 0.031	1
7	274425	PLUG SAE -10 HOLLOW HEX	1
8	601112	PLUG SAE -06 HOLLOW HEX	1
9	488970P	PLUG SAE -04 HOLLOW HEX	3
10	691253	PILOT PISTON -10 SINGLE W/OUT SEALS	2
11	691254	CART, CHECK VALVE 35 PSI	2
12	646208	CART, CHECK VALVE 5 PSI	1
13	691255	CART. CHECK VALVE REV 50 PSI	1
14	691256	CART, LOGIC SPOOL N/C L/S ELEMENT	1
15	691257	CART, RELIEF VALVE DIFF AREA 1200 PSI	1
16	691258	CART, NEEDLE VALVE, FINE ADJ.	1
17	691259	CART, NEEDLE VALVE	1
	691800	PWM VALVE KIT (RAVEN UNITS ONLY)	1
18	691260	CART, RELIEF VALVE 100-3000 PSI	1
19	691261	SAE-6, 0.120 ORIFICE CHECK	2
20	634103	FITTING 45 DEG -6 MJIC / -6 MORB	2
21	646200	GAUGE - 2.5" LIQUID, STEM MOUNT, SAE -4	1





**NOTES:**



---

**NOTES:**









## **Art's Way Manufacturing TECHNICAL MANUALS**

Manuals are available from your local dealer or Art's Way Manufacturing for the operation, service, and repair of your machine. For prompt convenient service, contact your local dealer for assistance in obtaining the manuals for your machine.

Manuals are also available at [WWW.ARTSWAY.COM](http://WWW.ARTSWAY.COM) free to download for your convenience.

Always give the Machine Name, Model, and Serial Number so your local dealer can provide the correct manuals for your machine.

Art's Way Manufacturing reserves the right to make improvements in design or changes in specifications at any time without incurring any obligation to install them on units previously sold.

Except as expressly authorized, no part of this manual may be reproduced, copied, transmitted, or disseminated, in any storage medium, for any purpose without the express prior written consent of Art's Way Manufacturing

**Art's Way Manufacturing**  
**Armstrong, Iowa, 50514, (712) 208-8467.**

**[WWW.ARTSWAY.COM](http://WWW.ARTSWAY.COM)**