

**Operator's Manual &  
Illustrated Parts List**

**Model 2400 & 3000  
Land Plane**

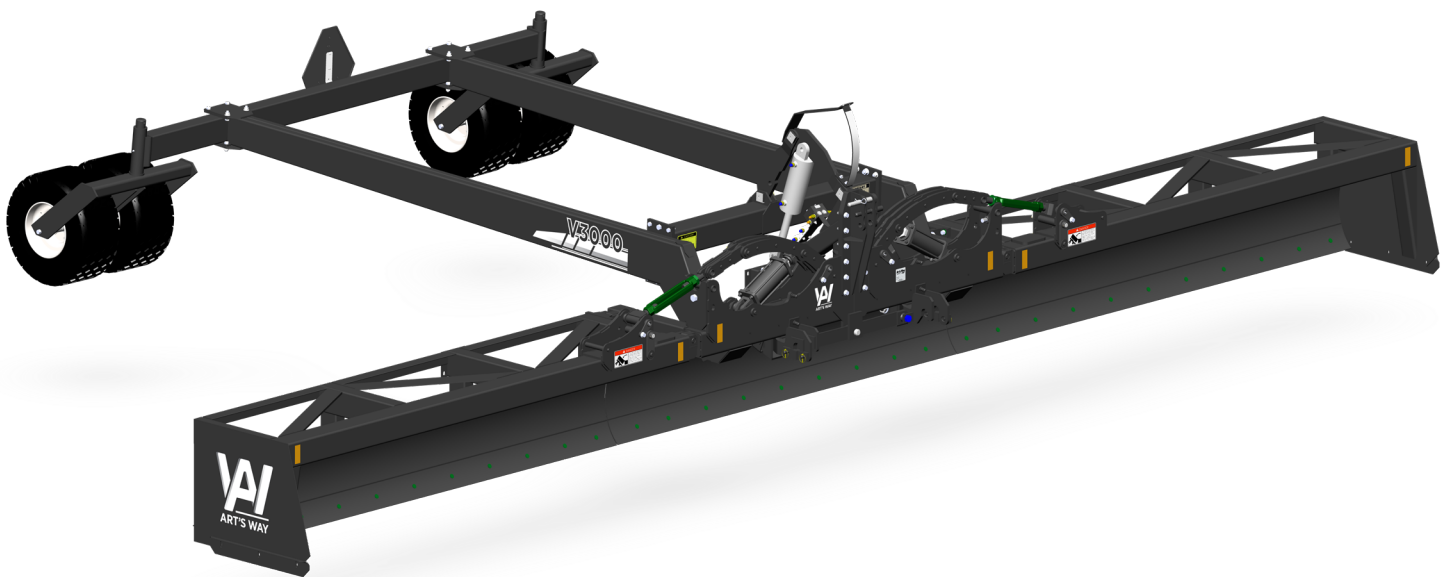

Art's Way Manufacturing

602805

Issued February 2024



This symbol means ATTENTION! BECOME ALERT! YOUR SAFETY IS INVOLVED. The message that follows the symbol contains important information about your safety. Carefully read the message. Make sure you fully understand the causes of possible injury or death.

IF THIS MACHINE IS USED BY AN EMPLOYEE, IS LOANED, OR IS RENTED, MAKE SURE THAT THE OPERATOR UNDERSTANDS THE TWO INSTRUCTIONS BELOW.

**BEFORE THE OPERATOR STARTS THE ENGINE:**

GIVE INSTRUCTIONS TO THE OPERATOR ON SAFE AND CORRECT USE OF THE MACHINE.

MAKE SURE THE OPERATOR READS AND UNDERSTANDS THE OPERATOR'S MANUAL FOR THIS MACHINE.

 **WARNING**

IMPROPER OPERATION OF THIS MACHINE CAN CAUSE INJURY OR DEATH.

**BEFORE STARTING THE ENGINE, DO THE FOLLOWING:**

1. READ THE OPERATOR'S MANUAL.
2. READ ALL SAFETY DECALS ON THE MACHINE.
3. CLEAR THE AREA OF OTHER PERSONS.
4. LEARN AND PRACTICE SAFE USE OF MACHINE CONTROLS IN A SAFE AND CLEAR AREA BEFORE YOU OPERATE THIS MACHINE ON A JOB SITE.

It is your responsibility to observe pertinent laws and regulations and to follow manufacturer's instructions on machine operation and maintenance.

See your Authorized Art's Way Manufacturing dealer or Art's Way Manufacturing for additional operator's manuals, illustrated parts catalogs, and service manuals.

---

## **TO THE OWNER**

Congratulations on the purchase of your new Art's Way Land Plane. You have selected a top quality machine that is designed and built with pride to ensure you have many years of efficient and reliable service.

Many people have worked on the design, production, and delivery of this Land Plane. The information in this manual is based on the knowledge, study, and experience through years of specializing in the manufacturing of farm machinery. This manual is designed to provide you with important information regarding safety, maintenance, and machine operation so you can and will get the best possible performance from your Land Plane.

Even if you are an experienced operator of this or similar equipment, we ask that you read this manual before operating this Land Plane. The way you operate, adjust, and maintain this unit will have much to do with its successful performance. Any further questions you may have about this product of Art's Way equipment should be directed to your local Art's Way dealer or to Art's Way Manufacturing, Armstrong, Iowa, 50514, (712) 208-8467.

### **SPECIFICATIONS AND DESIGN ARE SUBJECT TO CHANGE WITHOUT NOTICE**

Art's Way Manufacturing is continually making product improvements. In doing so, we reserve the right to make changes and/or add improvements to our products without obligation for the equipment previously sold.

Modifications to this Land Plane may affect the performance, function, and safety of its operation. Therefore, no modifications are to be made without the written permission of Art's Way Manufacturing. Any modification made without the written permission of Art's Way Manufacturing shall void the warranty of this product.

In the interest of continued safe operation of this Land Plane, pay particular attention to the safety alert symbol(s) throughout this manual.

### **Art's Way Manufacturing STATEMENT OF PRODUCT LIABILITY**

Art's Way Manufacturing recognizes its responsibility to provide customers with a safe and efficient product. Art's Way Manufacturing, attempts to design and manufacture its products in accordance with all accepted engineering practices effective at the date of design. This statement should not be interpreted to mean that our products will protect against the user's own carelessness or failure to follow common safety practices nor will Art's Way Manufacturing, be liable for any such act. In addition, Art's Way Manufacturing, assumes no liability for any altered product or any modified product by users or anyone other than an authorized dealer.

### **IMPORTANT WARRANTY INFORMATION**

The warranty for this Land Plane appears on page 6 of this manual. In order to establish proper warranty registration, the Warranty Registration must be completed and returned to the factory. Failure to comply with this requirement will result in invalidating the warranty!

### **LIMITATIONS OF THIS MANUAL**

This manual contains operating instructions for your 2400 & 3000 Land Plane only. Any mention of other machinery in this manual other than the 2400 & 3000 Land Plane is for reference only. This manual does not replace nor is it to be used for any machinery that may be attached to or used in conjunction with the 2400 & 3000 Land Plane.

**PARTS & SERVICE**

As the purchaser of your new plane, it is very important to consider the following factors:

**A. Original Quality**

**B. Availability of Service Parts**

**C. Availability of Adequate Service Facilities**

Art's Way Manufacturing has an excellent dealership network ready to answer any questions you may have about your plane. Parts for your machine may be ordered through our dealers. When placing a parts order, please have the **model** and **serial number** ready. This will allow the dealer to fill your order as quickly as possible.

You can find your serial number on the serial number tag on the front of your Land Plane by the left hand wing cylinder.

For your convenience, we have provided this space for you to record your model number, serial number, and the date of purchase, as well as your dealer's name and address.

**VAI**

**ART'S WAY**

**SERIAL NUMBER**

**MODEL**

Barcode



## TABLE OF CONTENTS

TO THE OWNER	1
SPECIFICATIONS AND DESIGN ARE SUBJECT TO CHANGE WITHOUT NOTICE	1
Art's Way Manufacturing STATEMENT OF PRODUCT LIABILITY	1
IMPORTANT WARRANTY INFORMATION	1
LIMITATIONS OF THIS MANUAL	1
<u>PARTS &amp; SERVICE</u>	<u>2</u>
TABLE OF CONTENTS	3-5
<u>SAFETY FIRST</u>	<u>7</u>
NOTICES OF DANGER, WARNING, AND CAUTION	7
<u>Safety Instructions</u>	<u>8</u>
GENERAL	8
BEFORE OPERATING	9
DURING OPERATION	9
MAINTENANCE SAFETY	9
HYDRAULIC SAFETY	10
TRANSPORTATION SAFETY	10
STORAGE SAFETY	10
TIRE SAFETY	11
ASSEMBLY SAFETY	11

<b>TABLE OF CONTENTS</b>	
<b>NAME</b>	<b>PAGE</b>
~~~~ OPERATORS INSTRUCTIONS ~~~~	13
SAFETY DECALS	14
DECALS	15
DECALS	16
ASSEMBLY INSTRUCTIONS	17
HITCH TUBE ASSEMBLY, 2400-3000 PLANES	18
ASSEMBLY INSTRUCTIONS, 2400-3000 PLANES	19
ASSEMBLY INSTRUCTIONS, 2400-3000 PLANES	20
ASSEMBLY INSTRUCTIONS, 2400-3000 PLANES	21
WHEEL ASSEMBLY, 2400-3000 PLANES	22
ATTACHMENT TO TRACTOR, QUICK ATTACH HITCH	24
TRANSPORTING, ALL PLANES	25
BEFORE GOING INTO FIELD, ALL PLANES	26
OPTIONAL SPRINGTINE ATTACHMENT, ALL PLANES	28
2400 TINE PATTERN	32
WING ASSEMBLY, RIGHT	34
WING ASSEMBLY, LEFT	36
MOLDBOARD ASSEMBLY, CENTER	38
WING LIFT ASSEMBLY	39
WING CONNECTION ASSEMBLY	40
HITCH ATTACH ASSEMBLY	41
TURNBUCKLE LEFT/RIGHT ASSEMBLY	42
TURNBUCKLE ASSEMBLY	43
BOOM ASSEMBLY	44
MAST ASSEMBLY, FRAME	45
CENTER LIFT ASSEMBLY	46
HITCH ASSEMBLY, QUICK ATTACH 558000	48
ASSEMBLY, CATEGORY 3 V180580	49
HITCH ASSEMBLY, CATEGORY 4N V180585	50
S-TINE ASSEMBLY, CENTER TO FRAME	51
S-TINE ASSEMBLY, RIGHT/LEFT TO FRAME	52
S-TINE ASSEMBLY, RIGHT/LEFT TO FRAME	53
S-TINE ASSEMBLY, CENTER TO FRAME	54
SINGLE WHEEL ASSEMBLY	55
SINGLE WHEEL ASSEMBLY, FRAME	57
DOUBLE WHEEL ASSEMBLY, FRAME	57

**THIS PAGE  
LEFT  
INTENTIONALLY  
BLANK**

FOR WARRANTY INFORMATION  
REFER TO THE SEPARATE DOCUMENT  
INCLUDED WITH THIS MANUAL OR GET  
IT ONLINE FROM:

[WWW.ARTSWAY.COM](http://WWW.ARTSWAY.COM)

## SAFETY FIRST

### SAFETY INSTRUCTIONS

“A careful operator is the best insurance against an accident.” Quote from the National Safety Council.

Most accidents can be prevented if the operator:

1. Fully understands how the machine functions.
2. Can anticipate situations which may produce problems.
3. Can make necessary corrections before problems develop.

**THIS SYMBOL MEANS ATTENTION!  
BECOME ALERT!  
YOUR SAFETY IS INVOLVED!**



- Universal Safety Alert Symbol

The American Society of Agricultural Engineers has adopted the Universal Safety Alert Symbol as a way to identify areas of potential danger if the equipment is not operated correctly. Please be alert whenever you see this symbol in the manuals or on your plane.

Art's Way Manufacturing strives to make our equipment as safe as possible. The Art's Way 2400 & 3000 Land Plane conforms to applicable safety standards at the time of manufacturing. A safety conscious equipment operator makes an effective accident-prevention program complete.

Safety features and instructions for the plane are detailed in the Safety Guidelines section of this Operator's Manual. It is the responsibility of the owner to ensure that all operators read and understand the manual before they are allowed to operate the land plane. (Occupational Safety and Health Administration (OSHA) regulations 1928.57).

### NOTICES OF DANGER, WARNING, AND CAUTION

Signal Words: Note the use of signal words **DANGER**, **WARNING**, and **CAUTION** on the plane and in this manual. The appropriate signal word for each has been selected using the following guidelines:

### ⚠ **DANGER**

Indicates a hazardous situation which, if not avoided, will result in death or serious injury.

### ⚠ **WARNING**

Indicates a hazardous situation which, if not avoided, could result in death or serious injury.

### ⚠ **CAUTION**

Indicates a potentially hazardous situation which, if not avoided, could result in minor or moderate injury.

### **NOTICE**

NOTICE is used to address practices not related to physical injury.

### SAFETY INSTRUCTIONS

Safety instructions (or equivalent) signs indicate specific safety-related instructions or procedures.

**Note:** Contains additional information important to a procedure and will be found within the regular text body of this manual.

## SAFETY INSTRUCTIONS

### GENERAL

Most work related accidents are caused by failure to observe basic safety rules or precautions. An accident can often be avoided by recognizing potentially hazardous situations before an accident occurs. As you operate and maintain the land plane you must be alert to potential hazards. You should also have the necessary training, skills, and tools to perform any assembly procedure.

**Improper operation and/or maintenance of this unit could cause a dangerous situation that results in injury or death.**

**Do not use this unit until you read and understand the information contained in this manual. Do not use this equipment for anything other than its intended purpose.**



Safety precautions and warnings are provided in this manual and on the unit. If these hazard warnings are not heeded, bodily injury or death could occur to you or to other persons.

Art's Way Manufacturing cannot anticipate every possible circumstance that might involve a potential hazard. The warnings in this manual and on the product are, therefore, not all-inclusive. If a method of operation not specifically recommended by us is used, you must satisfy yourself that it is safe for you and for others. You should also ensure that the unit will not be damaged or be made unsafe by the methods that you choose.

The information, specifications, and illustrations in this manual are based on the information that was available at the time this material was written and can change at any time.

### Safety Alert Symbols



death.

This is the safety alert symbol. It is used to alert you to potential personal injury hazards. Obey all safety messages that follow this symbol to avoid possible injury or

This manual contains DANGERS, WARNINGS, CAUTIONS, NOTICES, SAFETY INSTRUCTIONS, and NOTES which must be followed to prevent the possibility of improper service, damage to the equipment, personal injury, or death. The following key words call the readers attention to potential hazards.

Hazards are identified by the "Safety Alert Symbol" and followed by a signal word such as "DANGER", "WARNING", or "CAUTION".

**SAFETY  
INSTRUCTIONS**

**Remember:  
"The Best Operator is a Safe Operator"**

**CAUTION**



Read and understand the operator's manual and all the safety decals before operating the plane. Review all safety instructions with all operators annually.

## BEFORE OPERATING

SAFETY  
INSTRUCTIONS

Do not wear loose fitting clothing as it may catch in moving parts.



Make sure all guards and shields are installed, including the tractor power take-off (PTO) master shield, before starting or operating the plane.



Be sure that the correct implement driveline parts are used and that they are properly secured.

Lower the lifter wheels when the plane is not in use.

Install safety chain when attaching the plane to the tractor.



Clear the area of bystanders, especially children, when making repairs, adjustments, or performing maintenance on the plane.



Do not allow riders.

Put all tractor and machine controls in “neutral” and disengage the PTO before starting. Follow the starting instructions according to the OEM tractor manual.



Operate the plane only while seated on the tractor seat.



Make sure the unit is adequately supported with safety blocks or safety stands when changing tires or performing maintenance.

## DURING OPERATION

## CAUTION



**Entanglement Hazard**  
Keep hands, feet, hair, and clothing away from moving parts. Wait for all movement to

stop before approaching equipment.  
Before making adjustments:

1. Shut off the tractor,
2. Set parking brake,
3. Put machine in neutral, and
4. Remove key while making adjustments.



Keep all shields and guards in place and in good working condition.



Keep all bystanders, especially children, away from the plane while in operation.



Do not allow riders while the plane is in operation.



Do not attempt to unclog, clean, or adjust the plane while it is running.



Stay away from overhead power lines. Electrocutation can occur even without direct contact.



Keep all hydraulic lines, fittings, and couplers tight and free of leaks. (Refer to Safety Guidelines – Hydraulic Safety).



Use caution when ascending or descending on the plane. Wet shoes or boots are slippery.

## MAINTENANCE SAFETY

SAFETY  
INSTRUCTIONS

Follow all operating, maintenance, and safety instructions found in this Manual.



Before servicing, adjusting, repairing, or unclogging the machine, always make sure the tractor engine is stopped, key in your pocket, the machine is lowered to the ground, all controls are placed in neutral, the parking brake is set, and all the moving parts have stopped.



Use sufficient tools, jacks, and hoists that have the capacity for the job.



Use support blocks or safety stands when changing tires or performing maintenance.



Follow good shop practices of keeping the service area clean and dry, and use adequate light for the job at hand.



Before applying pressure to the hydraulic system, make sure all lines, fittings, and couplers are tightly secured and in good condition.



Make sure all shields/guards are in place and properly secured when performing maintenance.

## HYDRAULIC SAFETY

**SAFETY INSTRUCTIONS**

**Follow all operating, maintenance, and safety instructions found in this Manual.**

Make sure components in the hydraulic system are kept clean and in good working condition.



Relieve pressure from the hydraulic system before servicing or disconnecting from the tractor.



Keep all hydraulic lines, fittings, and couplers tightly secured and free of leaks.



Replace any worn, cut, abraded, flattened, or crimped hoses.



Do not make any temporary repairs to the hydraulic lines, fittings, or hoses using tape, clamps, or cement. The hydraulic system operates under extremely high pressure and temporary repairs may fail suddenly and create a hazardous/dangerous situation.



Wear proper hand and eye protection when searching for a high-pressure hydraulic leak. Use a piece

of wood or cardboard as a backstop instead of hands to identify and isolate a leak. If injured by a concentrated high-pressure stream of hydraulic fluid, seek medical attention immediately. Serious infection or toxic reaction can develop if hydraulic fluid penetrates the surface of the skin.



Before applying pressure to the system, make sure all components are tight and that the hydraulic lines, hoses, and couplings are not damaged.

**TRANSPORTATION SAFETY**

**SAFETY INSTRUCTIONS**

**Follow all operating and safety instructions found in this manual when transporting this equipment.**

Make sure the plane complies with all local regulations regarding transporting equipment on public roads and highways.



Make sure the Slow Moving Vehicle (SMV) emblem and all lights and reflectors required by local highway and transportation authorities are properly in place, clean, and clearly visible to traffic.



Do not allow riders on any machinery during transport.

Make sure the plane is securely attached to the tractor and install a safety chain to the plane.

Make sure the tractor brake pedals are latched together.

Do not exceed 20 mph (32 km/h) when transporting the plane. Always reduce speed on rough roads and surfaces, or when going down inclines.

Use caution when turning and always use the turn signals on the tractor to indicate your turning intentions to the other traffic.

The weight of the trailed machine should NEVER exceed the weight of the towing vehicle.

Check all clearances carefully whenever the machine is towed.

Set all features to transport position before transporting the plane on the roadway.



Stay away from overhead obstructions and power lines during transport. Electrocutation can occur even without direct contact.

**STORAGE SAFETY**

**SAFETY INSTRUCTIONS**

**Follow all operating and safety instructions found in this manual when storing this equipment.**



Store the plane in an area away from human activity.



Do not permit children to play on or around the stored machine at any time.

Make sure that the plane is stored in an area with a firm and level base to prevent the machine from tipping or sinking into the ground.



Block the wheels to prevent the machine from rolling.



**TIRE SAFETY****SAFETY  
INSTRUCTIONS**

Follow all operating and safety instructions found in this manual when working around tires.

Have only a qualified tire dealer or tire repair service perform tire repairs.

Do not attempt to install a tire on a wheel or rim unless you have the proper equipment and experience to do the job.

Do not substitute tires with a lesser road rating and/or capacity for the original equipment tires.

**WARNING**

**Explosive Force Hazard**  
Tire replacement, repair, and/or maintenance should be done by a qualified tire dealer or qualified repair service.

Failure to follow proper procedures when installing a tire on a wheel or rim can produce an explosive force that will result in serious injury or death.

Do not attempt to install a tire without proper equipment and experience to perform the job.

**ASSEMBLY SAFETY****SAFETY  
INSTRUCTIONS**

Follow all assembly, operating, and safety instructions found in this manual when assembly this equipment.



Use adequate manpower to perform assembly procedures safely.

Assemble the plane in an area with sufficient space to maneuver the largest components and allow easy access to all sides of the machine.



Use only forklifts, lift cranes, jacks, and tools with sufficient capacity for the loads.



Do not allow spectators, especially children, in the working area.

**THIS PAGE  
LEFT  
INTENTIONALLY  
BLANK**

**OPERATORS/ASSEMBLY INSTRUCTIONS**

## SAFETY DECALS

The following safety decals are located on your machine. Please take the time to familiarize yourself with them. KEEP ALL DECALS CLEAN AND FREE OF DIRT FOR MAXIMUM VISIBILITY. REPLACE ANY AND ALL DECALS THAT ARE NO LONGER LEGIBLE. READ AND OBEY ALL SAFETY DECALS



"DANGER" - describes hazard of wing hinge area and importance of transport lock.

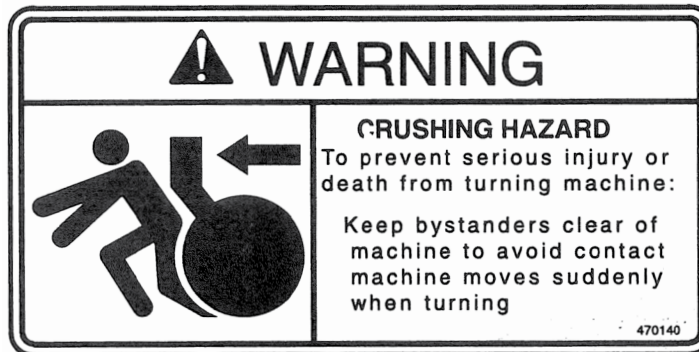

"CAUTION" - Lists 6 items to follow and observe while operating this machine.

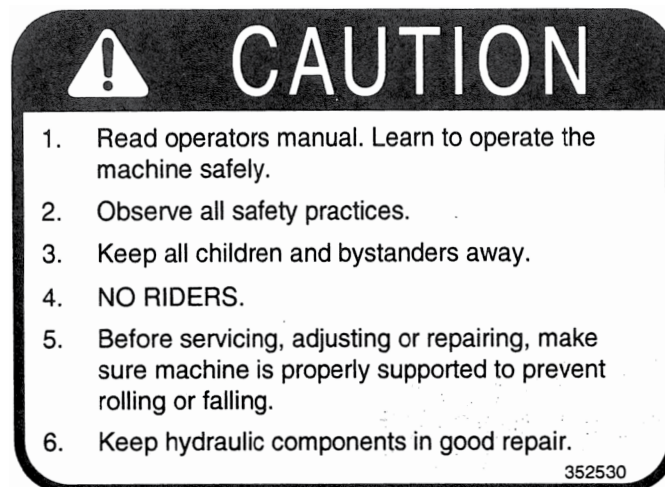

"WARNING" - Describes hazard of machine turning.

DECALS

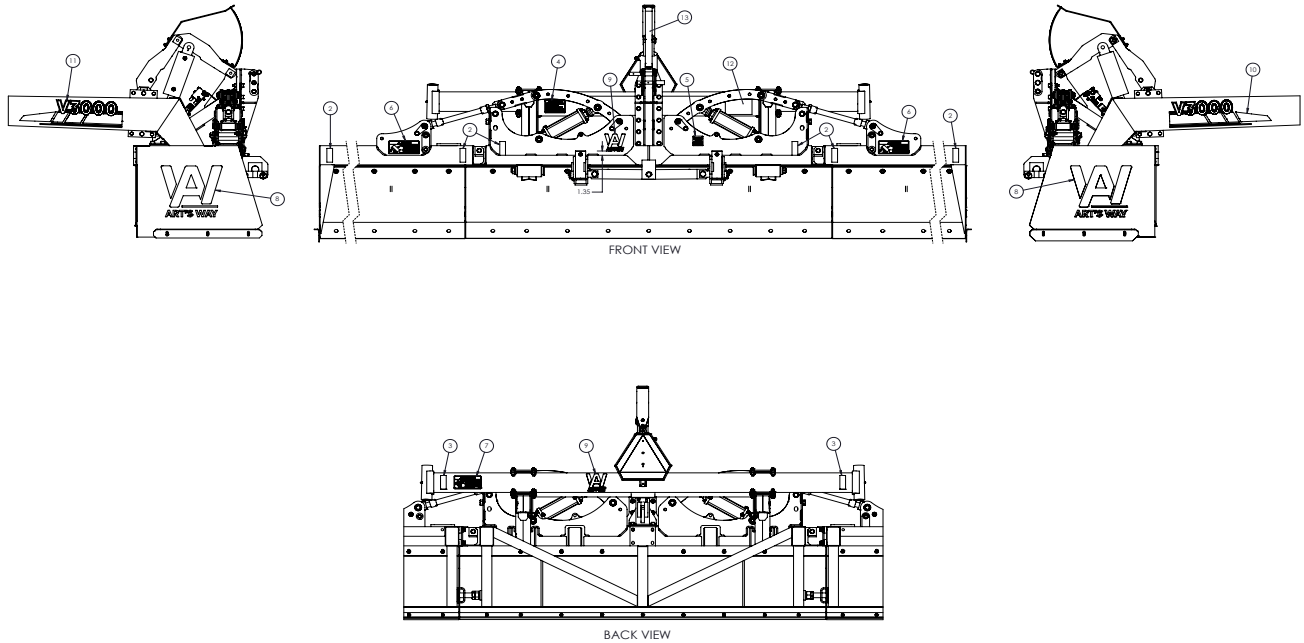

ITEM NO.	PART NUMBER	DESCRIPTION	QTY. 2400	QTY. 3000
1	146670	DECAL, GREASE SYMBOL		2
2	227420	REFLECTOR, AMBER		6
3	227430	REFLECTOR, RED		2
4	352530	DECAL, CAUTION READ		1
5	355600	TAG, SERIAL NUMBER		1
6	470130	DECAL, DANGER FALLING		2
7	470140	DECAL, WARNING CRUSHING HAZARD		1
8	720105	DECAL, NEW ARTS WAY LOGO		2
9	720120	DECAL, NEW ARTS WAY LOGO		2
10	720613	DECAL, V2400 LEFT	1	-
	720615	DECAL, V3000 LEFT	-	1
11	730614	DECAL, V2400 RIGHT	1	-
	720616	DECAL, V3000 RIGHT	-	1
12	V180588	DECAL, PRE-OPERATION CHECK LIST		1
13	V180565	DECAL, INDICATOR		1

**DECALS**

TORQUE GUIDE, SAE GRADE IDENTIFICATION

**TIGHTENING TORQUE GUIDE, SAE GRADE 5 - COARSE THREAD**

SIZE	CLAMP LOAD	PLAIN	PLATED
1/4 - 20(.250)	2,025	8 ft. lbs.	76 in. lbs.
5/16 - 18(.3125)	3,338	17 ft. lbs.	13 ft. lbs.
3/8 - 16(.375)	4,950	31 ft. lbs.	23 ft. lbs.
7/16 - 14(.4375)	6,788	50 ft. lbs.	37 ft. lbs.
1/2 - 13(.500)	9,075	76 ft. lbs.	57 ft. lbs.
9/16 - 12(.5625)	11,625	109 ft. lbs.	82 ft. lbs.
5/8 - 11(.625)	14,400	150 ft. lbs.	112 ft. lbs.
3/4 - 10(.750)	21,300	266 ft. lbs.	200 ft. lbs.
7/8 - 9(.875)	29,475	430 ft. lbs.	322 ft. lbs.
1 - 8(1.00)	38,625	644 ft. lbs.	483 ft. lbs.
1-1/8 - 7(1.125)	42,375	794 ft. lbs.	596 ft. lbs.

**IDENTIFICATION OF SAE BOLT GRADES; HEAD MARKINGS**

Grades 0, 1, and 2 no markings 

Grade 5: 3 radial dashes 120° apart 

Grade 8: 6 radial dashes 60° apart 

**ASSEMBLY INSTRUCTIONS**

**CAUTION:** While working on the machine be sure to work safely. Be sure to use adequate blocking. Use adequately rated lifting devices. Make sure all parts are secured before working under or near them.

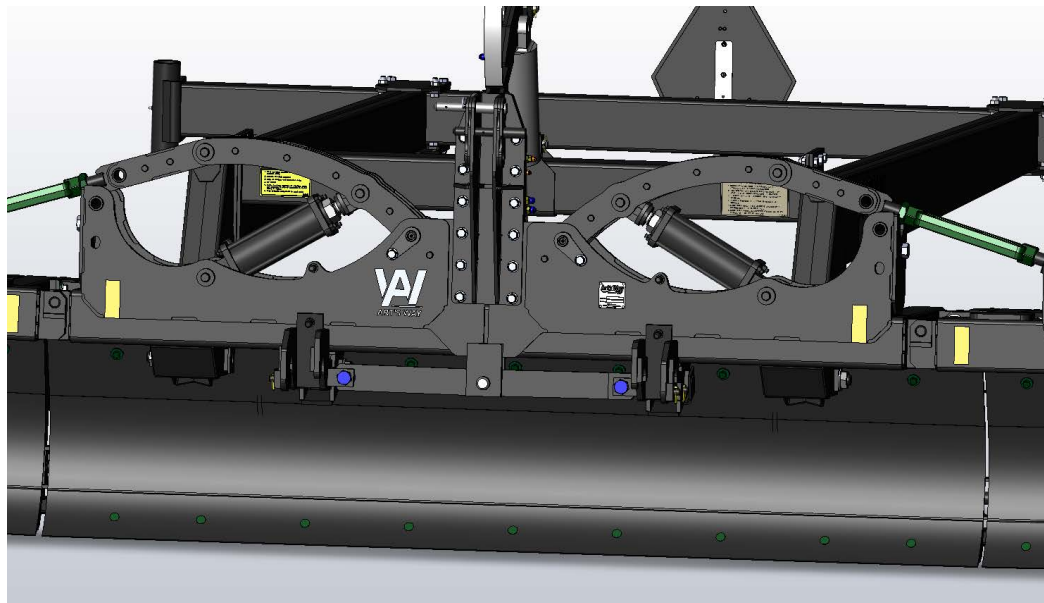

- A) Set the frame on a level area to assemble.
- B) Assemble in the recommended order.
- C) Support section with jack stands at indicated locations.

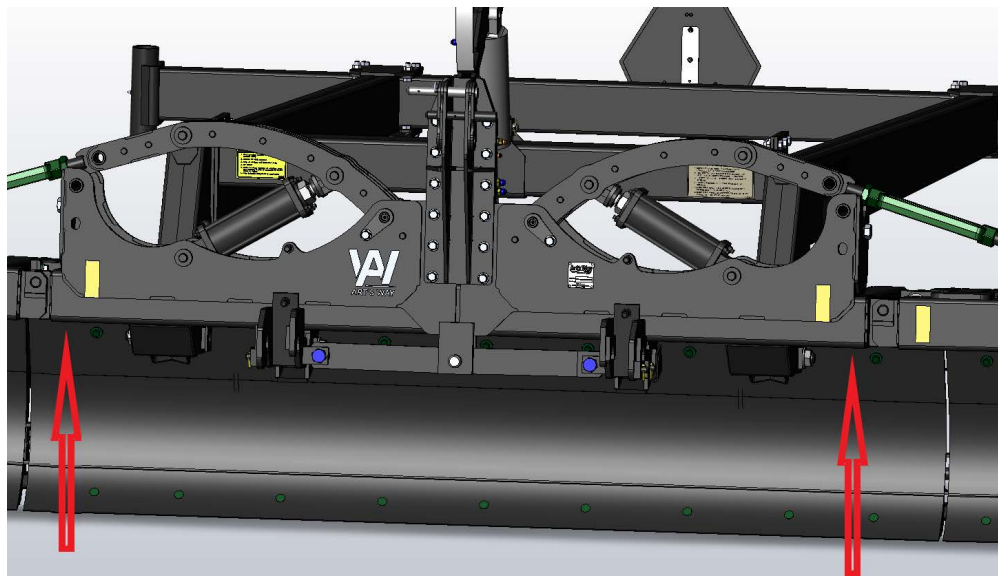

HITCH TUBE ASSEMBLY, 2400-3000 PLANES

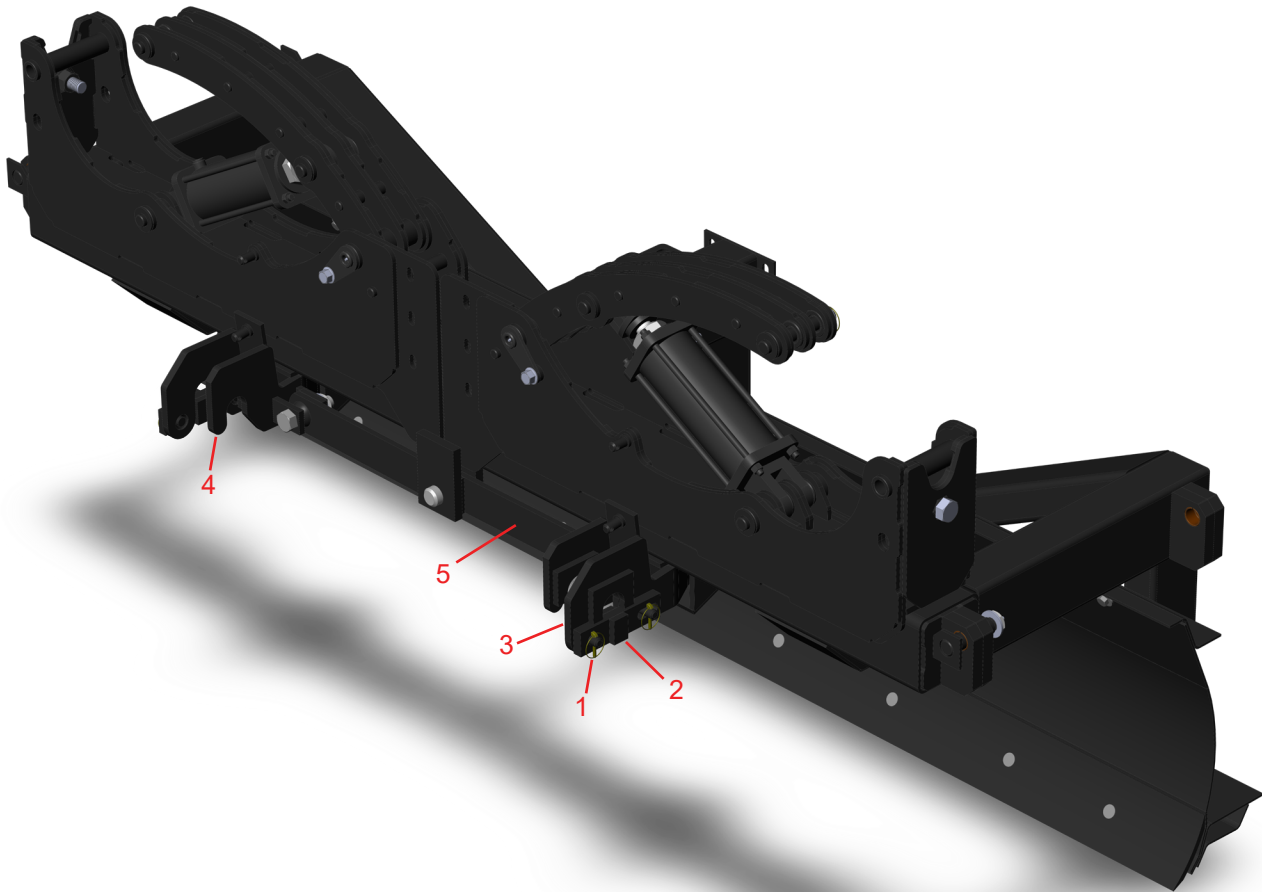



FIG. A

ITEM NO.	DESCRIPTION
1	1/4" LYNCH PIN (R66461)
2	BAR WLDT (V180366)
3	PLATE WLDT, LH (V180375)
4	PLATE WLDT, RH (V180376)
5	WLDT, CROSS LINK (V180378)

 Before assembling wings to center section, it will be easier to assemble the hitch fittings on the center section.

- 1) Attach L.H. and R.H. Hitch Plates (#3 & #4) to welded sockets under center section beam with hitch plate pins (#1) and 1-1/4" SAE flat washers and 1-1/4" elastic stop nuts.
- 2) Assemble cross links (#5) to hitch plates with 1" x 4" bolts and to center section bars with center cross pin and 1/4" x 2" roll pin.

\*NOTE: The welded pads on the ball socket ends of the cross links must be installed as shown in Fig A. (double plate in front on left side, double plate in rear on right side)

- 4) The hitch keeper bars (#2) are stored on the center section welded pins with VI80579 lynch pins.



ASSEMBLY INSTRUCTIONS, 2400-3000 PLANES

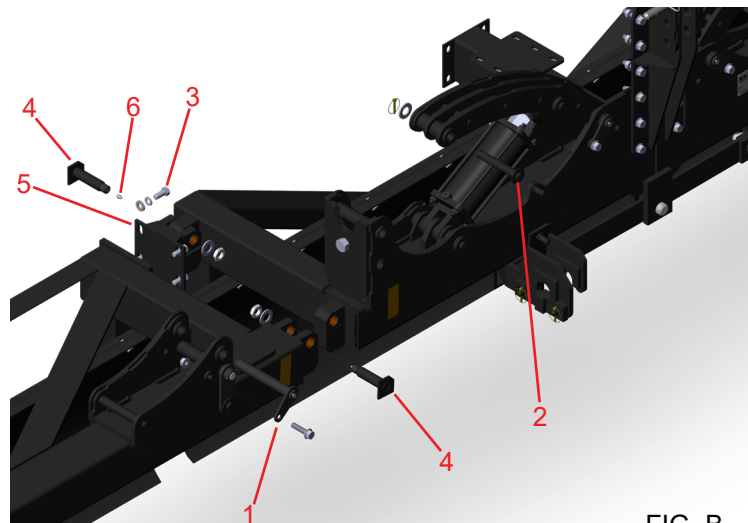

FIG. B

ITEM NO.	DESCRIPTION
1	PIN WELDMENT (661250)
2	PIN, 1" X 6-1/4" (661255)
3	BOLT, HHCS 5/8-11 X 1 1/2 (990610)
4	JP ASSEMBLY (V180642)
5	HINGE, ADJUSTABLE (V180138)
6	FITTING, GREASE 1/8-27 NPT (013170)

- 1) Loosen bolts (#3) and install #4 pin then tighten in.
- 2) Lift wings into place and install pin #4 into hinge joint with washer (1107389) and nut (V066513).
- 3) Assemble Turnbuckles and install on to frame with pin #1. Lock with Bolt (600310) and nut (600150). Top gets attached with pin #2, washer (1107389) and pin (R66461). Leave loose until finally adjustments.

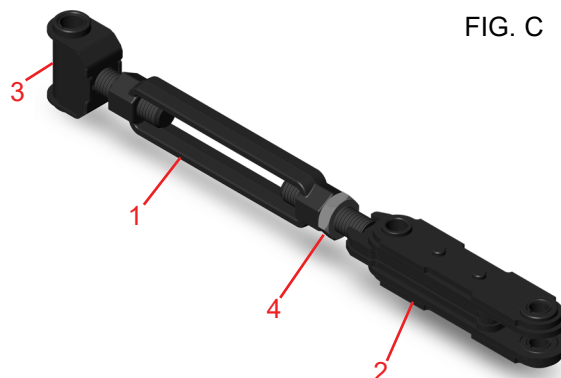

FIG. C

ITEM NO.	DESCRIPTION
1	TURNBUCKLE (599210)
2	CLEVIS WELDMENT (661225)
3	LINK END WELDMENT (661265)
4	NUT, JAM 1 1/2-6 HEX ZN (V062146)

**ASSEMBLY INSTRUCTIONS, 2400-3000 PLANES**

FIGURE D

1) Using a saw horse or overhead sling to support the rear end, attach R.H. boom (#5) to center section welded lugs with boom pin (#6) and 1-1/4" SAE Hat washer (#2) and 1-1/4" elastic stop nut (#3). And then install grease zerk (#1). Note the welded vertical plates must be toward the inside. Attach L.H. boom (#4) in same manner.

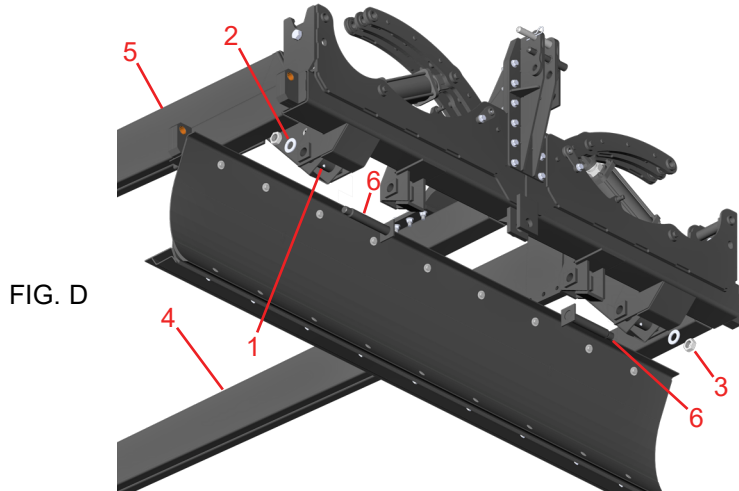

ITEM NO.	DESCRIPTION
1	FITTING, GREASE STRAIGHT (013170)
2	WASHER, FLAT 1.25 SAE (E829022)
3	NUT, JAM 1-1/4-12 (V066516)
4	BOOM WLDT LH (V180167)
5	BOOM WLDT RH (V180168)
6	BOOM PIN (V180243)

Attach front cross tube (#7) to booms (#5) and (#6). NOTE: From Figure E that 2 - 3/4" x 2" special bolts (#4) are installed first, on both sides, in the top and bottom middle holes before inserting the other 5/8" x 1-3/4" bolts (#1).

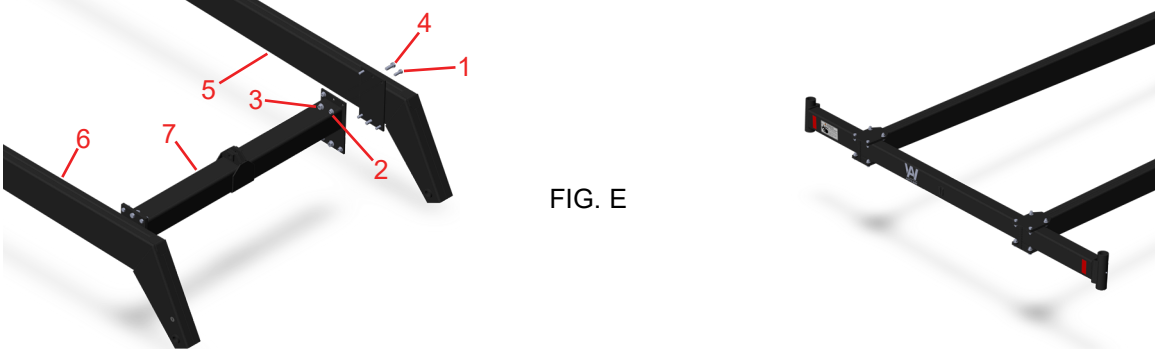

ITEM NO.	DESCRIPTION
1	BOLT, HHCS 5/8-11 X 1 3/4 (025100)
2	NUT, HFH NYLOC 5/8-11 (600150)
3	NUT, HFH TOPLOCK 3/4-10 (600160)
4	BOLT, HHCS 3/4-10 X 2.0 (V061704)
5	BOOM WLDT LH (V180167)
6	BOOM WLDT RH (V180168)
7	WLDT, FRONT (V180455)

ASSEMBLY INSTRUCTIONS, 2400-3000 PLANES

FIGURE F and G

- 1) Attach mast to rear beam of center section with 6 - 5/8" x 1-3/4" bolts. Attach the Top link mount and tighten all mast bolts starting with the bottom ones.
- 2) Assemble the cylinder and the arm assembly with associated hardware.

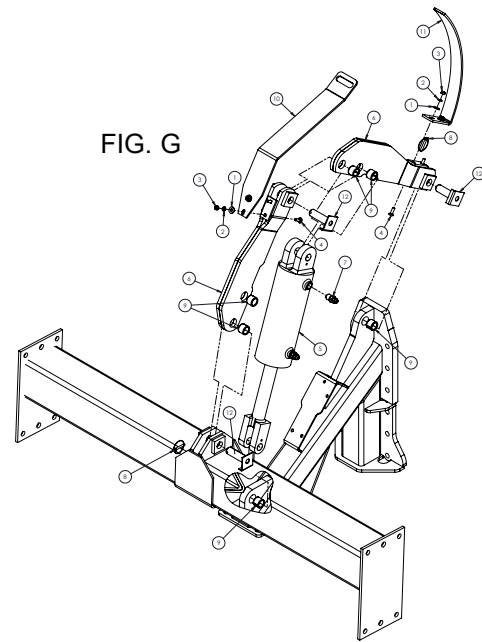
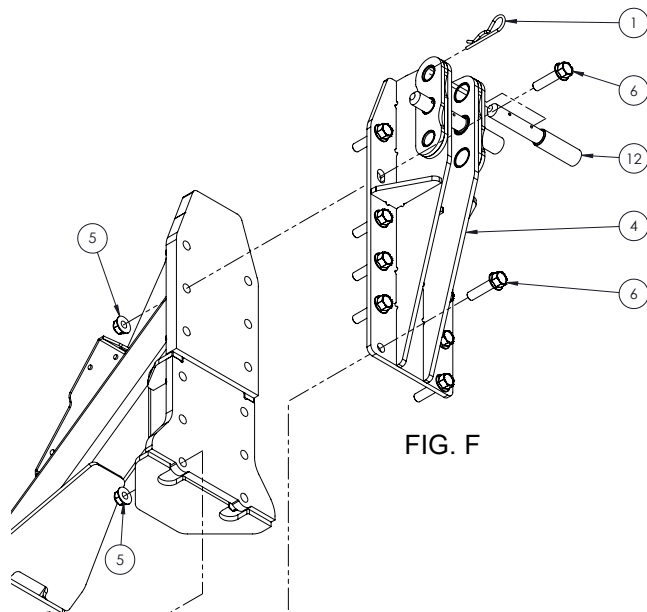

ITEM NO.	DESCRIPTION
1	PIN, COTTER 3/16 X 1-1/2 ZN (035830)
4	MOUNT, TOP LINK (599023)
5	NUT, HFH NYLOC 5/8-11 (600150)
6	BOLT, HFH 5/8-11 X 2-1/2" (600310)
12	PIN, STEP UPPER (V180631)

ITEM NO.	DESCRIPTION
1	WASHER, FLAT 5/16 STD (022920)
2	WASHER, LOCK 5/16 (023620)
3	NUT, HEX 5/16-18 (023630)
4	BOLT, CRG 5/16-18 X 1" (254060)
5	CYLINDER, HYD (510640)
6	ARM ASSY, (569830)
7	FITTING, HYD STRAIGHT (637030)
8	1/4" LYNCH PIN (R66461)
9	BUSHING, STEEL (V180220)
10	STRIP, GAUGE (V180542)
11	STRIP, GAUGE DECAL (V180543)
12	WLDT, CLEVIS PIN (V180647)

FIGURE G -Depth Control 8" Stroke Cylinder

- 1) Attach gauge marker strip (#11) with 5/16" x 1" carriage bolts and lockwashers; and gauge decal mounting strip (#10) to links as shown with 5/16" x 1" carriage bolts, flat washers and lockwashers, adjusting the mounting strips if necessary.
- 2) Attach link arms (#6) to each other, and to the mast and front cross beam with clevis pins (#12) and lynch pins. Note that the two link arms are identical so there will be an unused hole in one of them. \*Also note the holes in these links are not on the centerline, and the top link should first be pinned to the cylinder clevis before assembling it to the mast and vertical link.
- 3) Assemble fixed end of 8" stroke cylinder (#5) to top link arm (#6); and the rod end to the lug welded on the mast, with clevis pins (#12) and 1/4" x 2" lynch pin.

**WHEEL ASSEMBLY, 2400-3000 PLANES**

**NOTE: The welded-on SMV bracket must be up and toward the rear of the Plane.**

1) It is more convenient to assemble the easier wheel assemblies on the rear cross beam (Fig #4) before the cross beam is attached to the booms. Normally there are three machine washers (#2) installed at the base of the beam welded tube. A 1/2" x 3" roll (#3) holds the caster yoke on the rear beam.

NOTE: Additional washers are provided to level out the cutting blade if that is necessary.

2) The rear cross tube is attached to the booms with 8 - 5/8" x 1-3/4" bolts and lock washers. Now thoroughly tighten all bolts holding the front and rear cross beams to the booms.

**NOTE ASSEMBLY PERSONNEL:**

When the booms are assembled and the pin (#15) is installed, apply grease at once. This will permit the pin to be removed if necessary in the future. Don't wait until later - grease pin NOW.

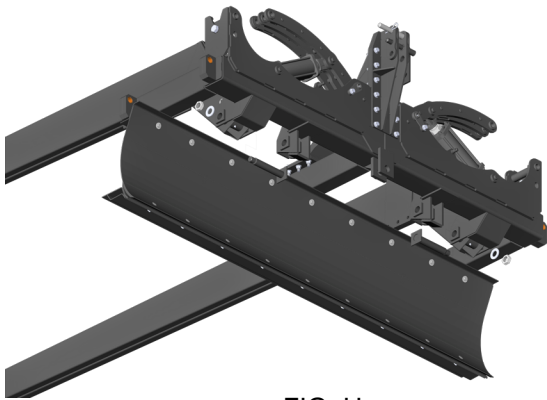

FIG. H



FIG. I

**OPTIONAL:**

Dual Caster Wheel Assembly - Kit No. V180597. Recommended for trashy, moist, loose soil conditions.

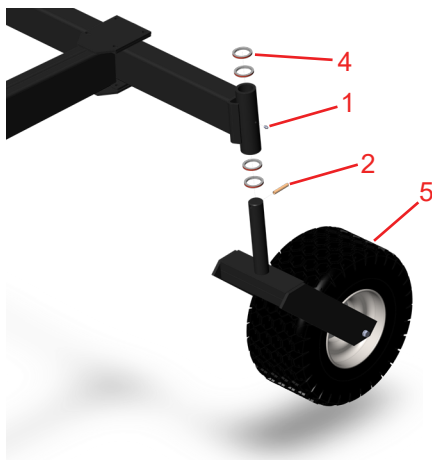

FIG. I-1

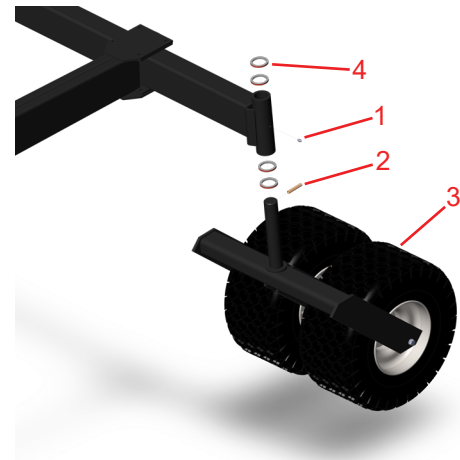
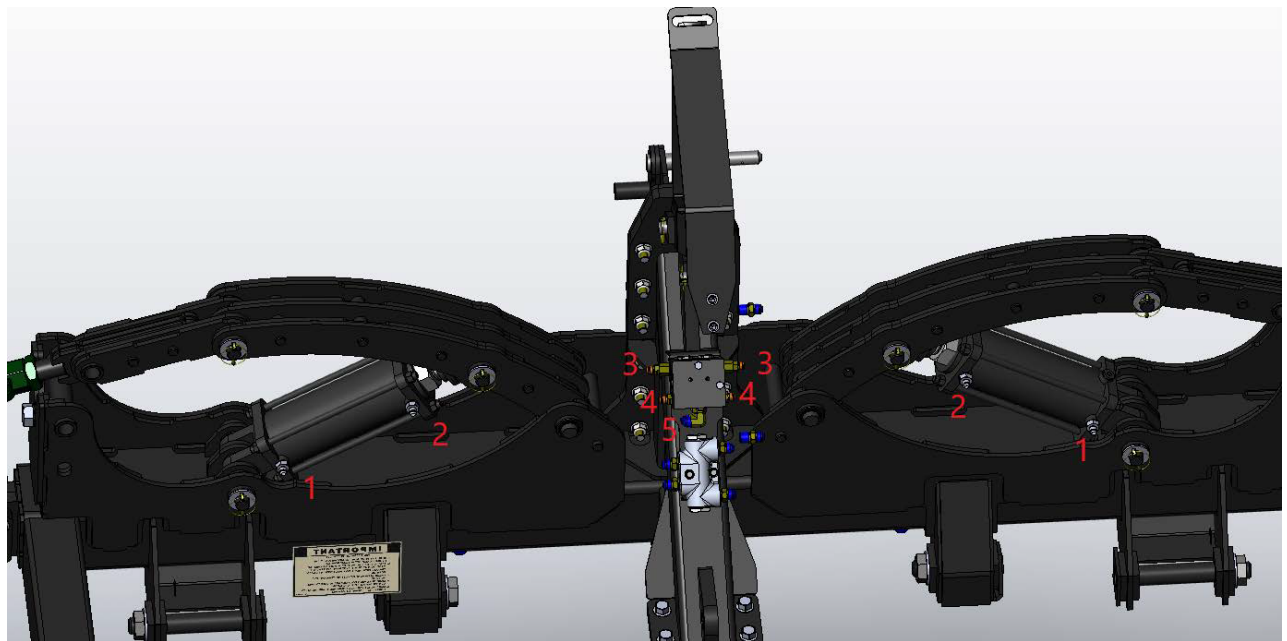
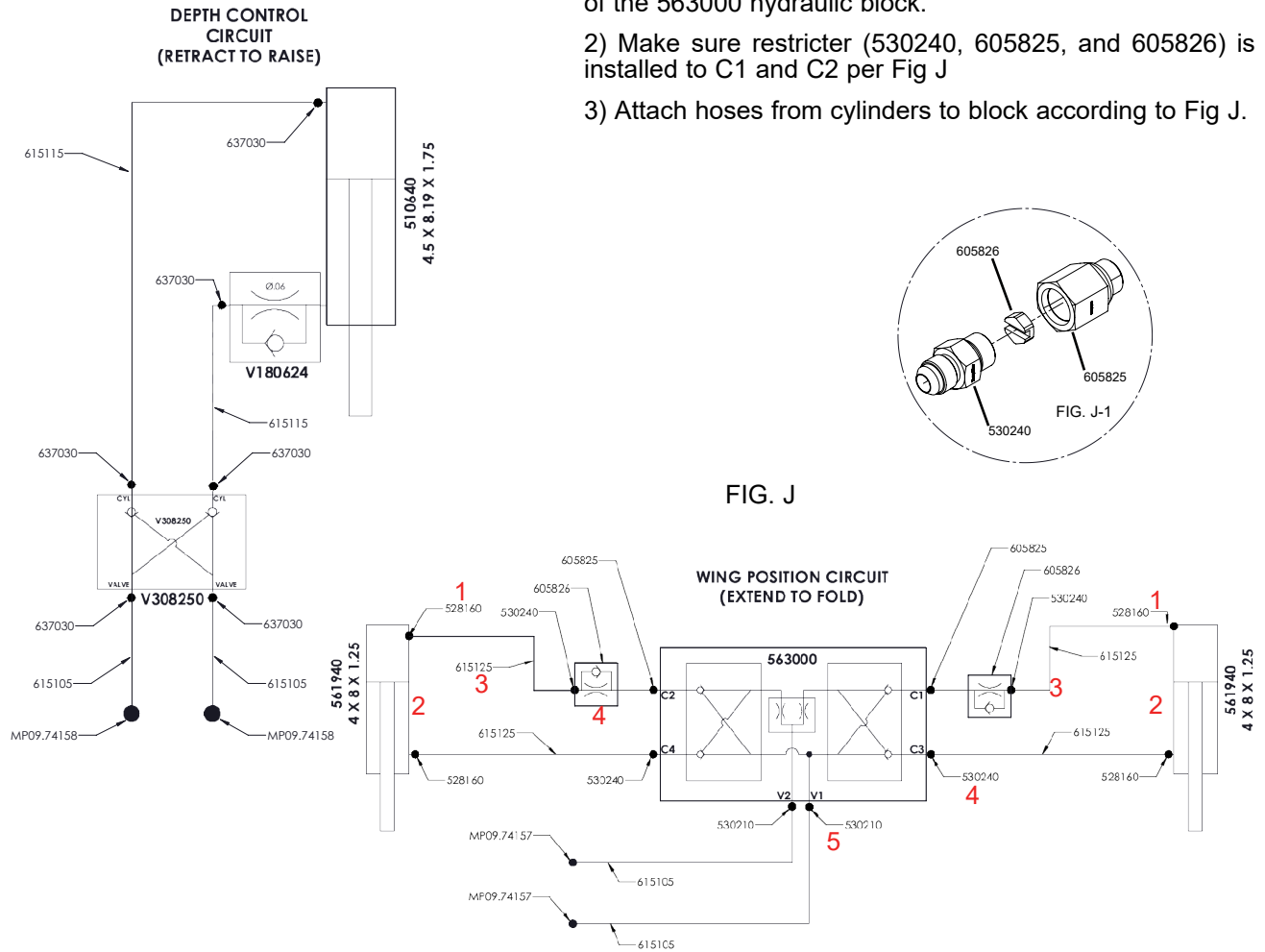

FIG. I-2

ITEM NO.	DESCRIPTION
1	FITTING, GREASE STRAIGHT (013170)
2	PIN, ROLL 1/2 X 3 ZN SLOTTED (V064499)
3	SINGLE CASTER HUB WHEEL (V180274)
4	WASHER, SPECIAL (V180428)
5	DUAL CASTER HUB WHEEL (V180865)

- 1) Attach 80" hoses (615105) to both bottom ports (V1/V2) of the 563000 hydraulic block.
- 2) Make sure restrictor (530240, 605825, and 605826) is installed to C1 and C2 per Fig J
- 3) Attach hoses from cylinders to block according to Fig J.



**ATTACHMENT TO TRACTOR, QUICK ATTACH HITCH**

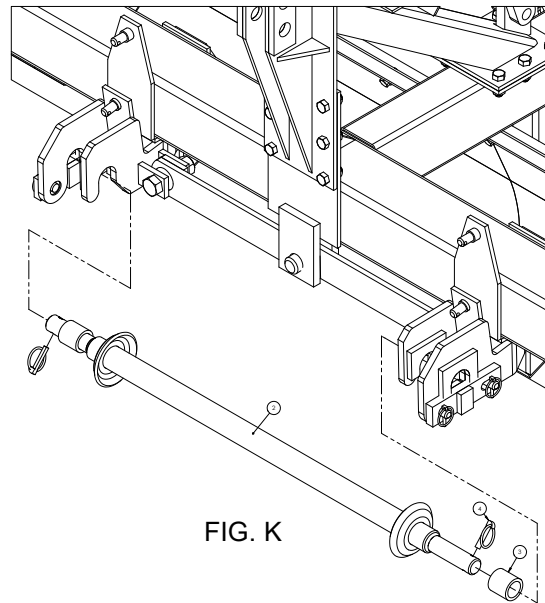

FIG. K

ITEM NO.	DESCRIPTION
2	HITCH BAR WLDMNT.
3	SLEEVE, OUTER
4	LYNCH PIN, 7/16X2

- 1) Attach Hitch Bar Assembly to tractor draft arms. Fig. L shows Cat. 3 extended, bar (V180799); Lynch pins (#4) secure bars.
- 2) Fasten hitch plates flush against center section with hitch keeper plates.
- 3) Back tractor up to Plane and lift draft arms up to nest hitch bar into hitch plates.
- 4) Then use hitch keeper plate, (#2) to lock bar in place with lynch pins (#3).
- 5) The tractor top link is attached to the mast with the upper step pin and a #4 hairpin. The step pin will fit either Cat. 2 or Cat. 3 top links. NOTE: Before attaching the tractor top link to any of the holes in the mast, first refer to section on "Tractor Preparation".

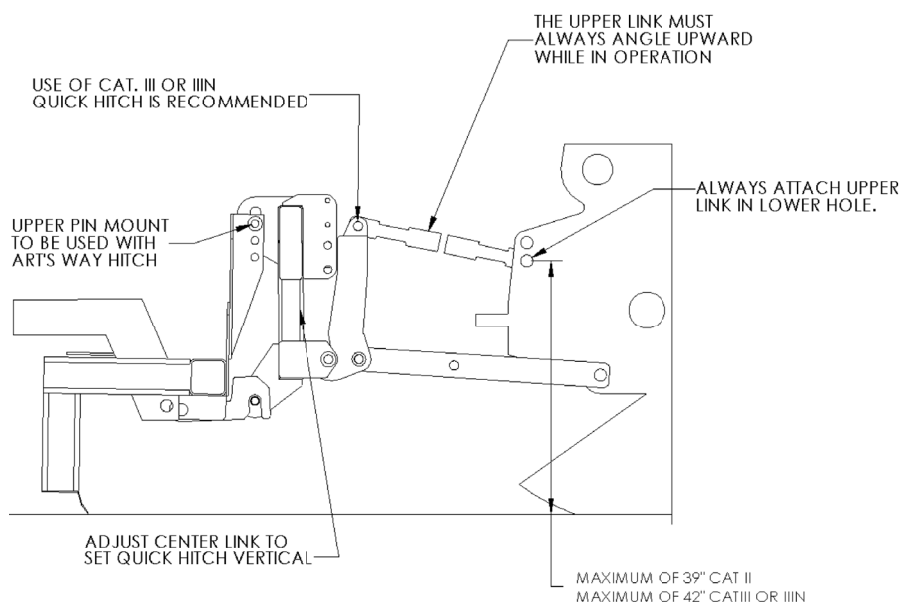
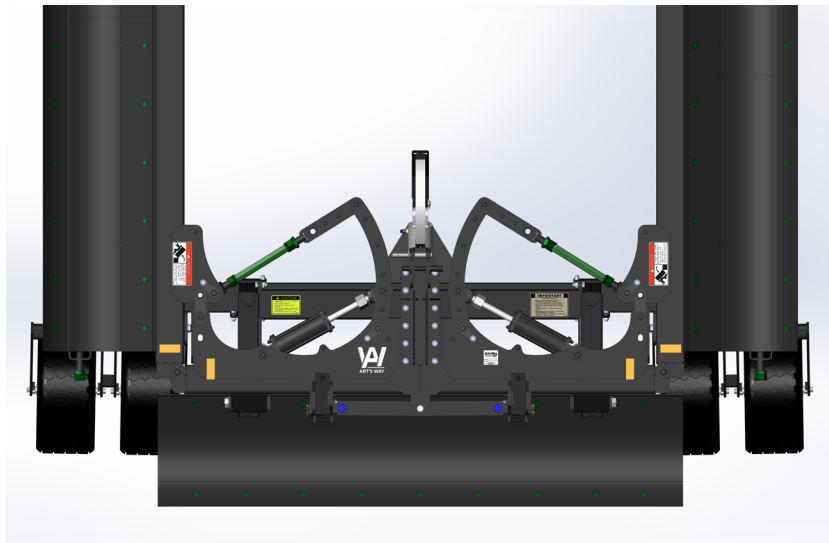

FIG. L

TRANSPORTING, ALL PLANES



TRANSPORTING



1) When transporting, lift moldboard clear of ground with depth control cylinder. Keep weight on rear wheels of Plane. Do not transport by lifting entire Plane off ground with tractor lift control.



2) Raise wings to vertical position and secure hinge latch pin (#1) to ears on center section with safety lock pin (#2). Hold pin in place with snapping. Do not transport without locking the wings.

ITEM NO.	DESCRIPTION
1	Wing Lock Weldment (661245)
2	Pin, Lock Selector (661285)
3	Pin, Wing Lock (661266)

Occasionally, the adjustable turnbuckle (Fig. N) will need to be adjusted to insure a positive contact of wing bits.

Then be certain the adjustable nut, (Fig M) on the rear of the machine is firmly against the stop pad and locked in place with the jam nut.

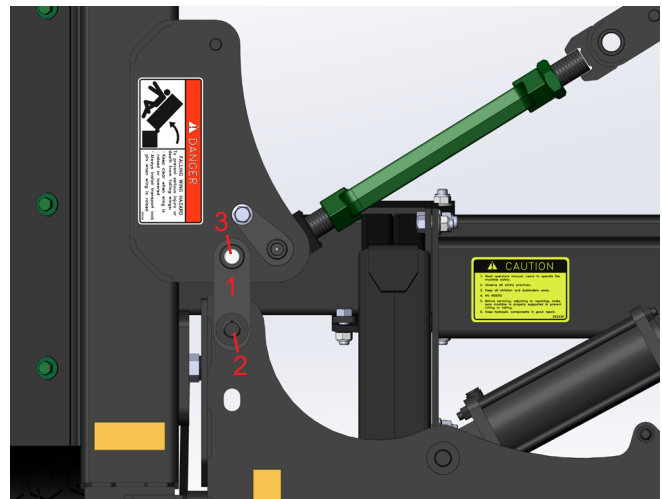

FIG. M

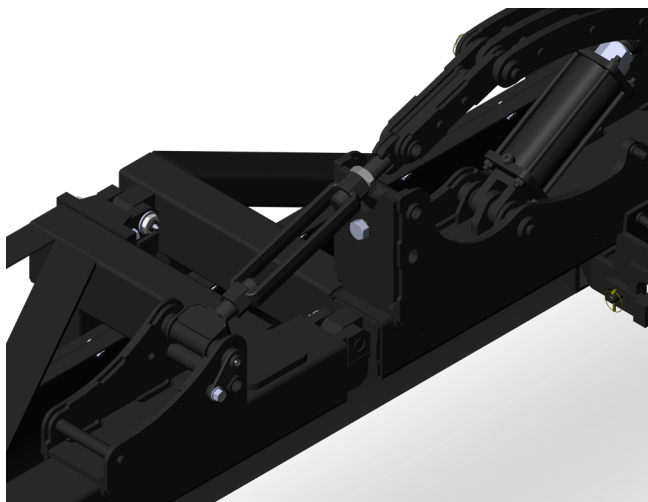

FIG. N



FIG. O



**BEFORE GOING INTO FIELD, ALL PLANES****A - Tractor Preparation**

- 1) On two-wheel drive tractors, weighted dual rear wheels are recommended for ease of turning and to improve traction.
- 2) A minimum of two tractor hydraulic controls valves is required to operate the V2400-V3000 Plane. (Three valves are necessary if the optional spring tooth attachment is installed.)
- 3) Be certain "IMPORTANT" decal is installed on front cross tube and that all tractor operators are familiar with the instructions detailed on the decal. On IHC tractors, the hitch depth control lever is moved forward to the offset, but not into the draft control range. Dial out the electronic draft on M-F tractors.
- 4) The tractor hitch lift arms must be set in float position so there is a free "mechanical" float. Be certain the lift arms are the same length.



- 5) Install hitch tube (Ref. Fig. L, page 24) on three-point lift arms. Caution - Be sure tube clears tractor drawbar when raising or lowering three-point hitch on tractor. On some tractors, drawbar may have to be removed. Tractor quick hitch cannot be used on Eversman Planes.

**B - Plane Preparation**

- 1) When attaching tractor to the Plane be sure keeper plates (Ref. #2, Fig. L, page 24) are installed on hitch link to secure hitch tube to the hitch links.
- 2) Attach tractor top link to mast with upper step pin and #6 hairpin (Refer. Fig. K, page 24). IMPORTANT - The top link must be at least 6 inches higher at the mast than at front pivot point on the tractor. The top hole in the mast will be used on most tractors.
- 3) Check tire inflation - must be no more than 20 pounds pressure.
- 4) Provisions have been made to align wings with center section. Two adjustments must be made in sequence. Stretch a string or wire from outer end to outer end of moldboard bits to check alignment. Adjust and lock the lower adjusting nut and jam nut (Refer. #5 & #6, Fig. O, page 25) when wings are aligned with the center section. Then adjust top adjustable link and lock jam nut (Refer. #4, Fig. C, page 19). The lock nuts should make firm contact against the center section plate.
- 5) Lubricate zerks on booms, castor wheels, hinge links and hinge link ends.
- 6) After filling the Plane cylinders, check the tractor hydraulic fluid level and refill if necessary.

**C - Transporting**

- 1) With tractor hitch control lever in maximum float position, raise the moldboard with depth control cylinder to leave weight on the rear tires for transport stability.
- 2) Operate wing lift cylinder to raise wings and install safety lock pins. (Refer page 25).
- 3) Do not transport the Plane by lifting it with the tractor three-point hitch.
- 4) Transport at safe road speeds (also refer to instructions on safety, page 7).
- 5) The wheels and tires are designed for 5 MPH field operation and intermittent 10 MPH road speeds. Do not exceed 10 MPH.



**D - Lubrication**

- 1) Each day during field operations, re-grease the zerks on the booms, castor wheels, hinge links and hinge link ends, and hinge pins.
- 2) Each year before starting to level, repack the castor wheel bearings.

**E - Storage**

- 1) When storing for the season, oil hinge joints and pins thoroughly
- 2) When restarting, if pins are rusted, loosen with penetrating oil.

**F - Field Operation Adjustment**

- 1) Adjust the tractor top link so that the mast is vertical to the ground. This will produce more rolling action of the soil in the moldboard. To obtain increased roll, shorten tractor top link slightly, approximately one-half turn. The sideboards must be parallel to the ground. If the sideboards are tilted nose down, the blade will not cut efficiently and turning will be difficult. If they are tilted nose up, soil will spill out the sides and the blade will not dump correctly.
- 2) Adjust the wear plates so they are parallel to the ground and at ground level.
- 3) The tractor hitch control lever must be operated in float position so there is a free "hydraulic" float. On older tractors which do not provide a "float" position, set the height of the tractor lift arms so that the hitch plates (Ref. #2 & #3, Fig. A, page 18) are in the middle of their travel limits when attached to the hitch tube assembly (also refer to page 24).
- 4) Set the blade control cylinder so the moldboard carries an average load about 2/3 full as you cross the field. Do not attempt to maintain a full load at all times. You are smoothing the field only when the moldboard empties at times indicating a low spot, and when it overflows at others, indicating a high spot or ridge. The first pass over a rough field will show a greater fluctuation of soil in the blade than on the second or third pass. If the rear wheels tend to come off the ground, you are either carrying too much soil in the moldboard, or you are supporting the blade with the tractor three-point system rather than letting the draft arms float. Note the setting on the depth indicator strip (#5, Fig. G, page 21) so that you can return the depth control cylinder to the correct level if it ever becomes necessary to change it.
- 5) If you are carrying more soil on one side than the other, the moldboard may not be entirely level. In this case, first be certain both rear tires have the same inflation. Then be sure the adjustable hinge bar locks into an over-center position; check the wing adjustment nuts (Fig. B, page 19); the adjustable hinge bar jam nut settings, (Fig. E, page 19); and be certain the special shoulder bolts in the front cross frame are tight (Fig. H, page 22). After checking all of the above items, it may be necessary to remove one or more of the washers on the castor wheel (Fig. I, page 22) to lower the side which is carrying less dirt.
- 6) Select the gear and speed to match field moisture and trash conditions.
- 7) Exercise caution to avoid catching ends of wings on ditch banks or posts.
- 8) Consider installing the optional springtine attachment on your Plane. This can be used to rough up the field to minimize blowing, and may save a separate trip by combining leveling with the springtooth tillage operation. Lift the springtine attachment before turning at field ends.
- 9) The horsepower requirements will depend on the soil and moisture conditions. The most difficult conditions will probably be a combination of moist, soft, loose textured soil. In those cases, you will possibly require better Rotation with dual wheels on the Plane and either less wheel weight or larger front tractor tires. In general, horsepower requirements will be: in normal soils 135 to 150 for the V3000. For difficult soils 180 for the V3000.

**OPTIONAL SPRINGTINE ATTACHMENT, ALL PLANES**

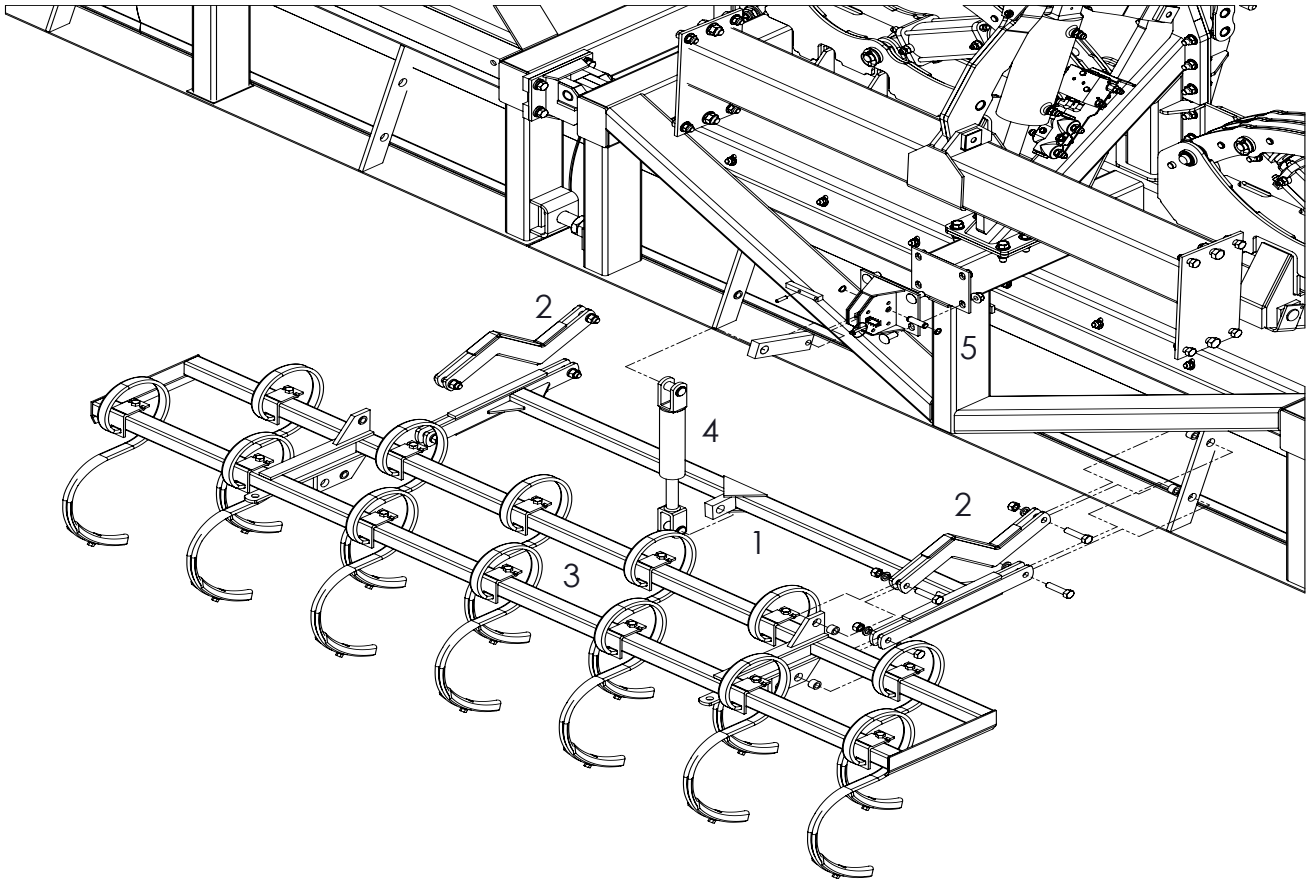

FIG. A

ITEMNO.	DESCRIPTION
1	LIFT TANK WELDMENT (V180304)
2	PARALLEL LINK (VI 80306)
3	STA FRAME
4	2" X 4" CYLINDER (V180910)
5	CYLINDER PIN (V701026)
6	BRACKET (V180557)
7	ANCHOR BAR (V180553)
8	PIVOTPIN(V180391)
9	E-RING (V067200) (2 REQ.)
10	ADJUSTMENT PIN (V180554) 5/16" X 1-1/4" ROLL PIN (V064410)
11	LYNCH PIN (V180579)

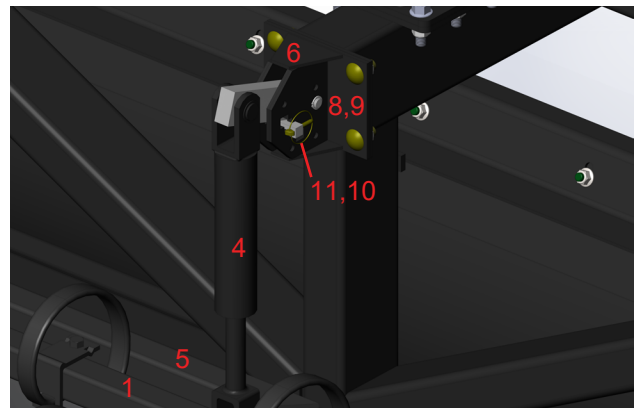
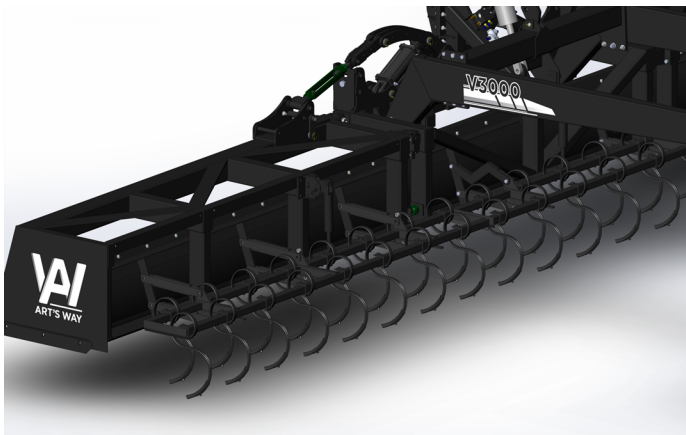

FIG. B

Figures A and B - Frame and Links

- 1) Attach lift link weldment (^1, Fig. B) to the bottom holes of the ribs, behind the moldboard, with 5/8" ID x 9/16" bushings and 5/8" x 2-1/2" hex bolts. It is possible to incorrectly assemble the lift link weldment which will result in cylinder damage. Observe from Fig. B, that the welded lug, to which the STA cylinder attaches, is to the rear of the lengthwise tube.
- 2) The top parallel links (#2) are assembled to the top holes of the ribs, also using the 5/8" ID bushings and 5/8" x 2-1/2" bolts.
- 3) Note from Figure A that the frame (#3) is assembled with the lug with one hole on the top. The top links are then attached to the top lugs of the frame (^3); and the lift link weldment is attached to the bottom, front, hole of the frame lug, also with bushings and 5/8" x 2-1/2" bolts.\*
- 4) The 2" x 4" stroke cylinders (#4) are connected to the lift link weldment with cylinder pins (^5) and 2 ° #6 hairpins. Observe that the ports of the left wing and center section cylinders must be on the right-hand side when the cylinders are assembled. The ports of the cylinder on the right wing must be on the left side of the cylinder. The rod end of the cylinder is at the bottom.
- 5) Attach adjustment bracket (^6) to main frame with 5/8" x 2-1/2" hex bolts. The anchor bar (#7) is assembled to the bracket with pivot pin (#8) and 2 - 5/8" E-rings (^9).
- 6) The adjustment pin (MO) is located in the bracket, with a 5/16" x 1-1/4" roll pin and lynch pin, to set the operating depth of the STA cylinder.



\*Note - Assembly of the springtines may require that the heads of some of these 5/8" bolts be reversed in order to maintain proper spacing of the tines.

ITEM NO.	DESCRIPTION
1	NUT, HEX 1/2-13 (005360)
2	WASHER, LOCK 1/2 (005370)
3	NUT, HEX 3/8-16 GR5 (027260)
4	HHCS, 1/2-13 X 3.25, G5, ZN (1770608)
5	BOLT, PLOW 1/2-13 X 2 (V059779)
6	S-TINE (V180423)
7	POINT FOR S-TINE (V180424)
8	CLAMP, S-TINE (V180425)

FIG. C

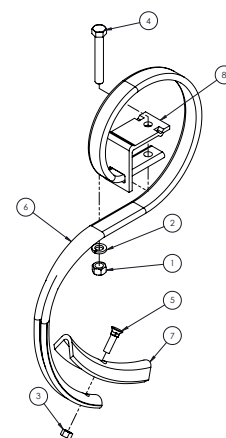

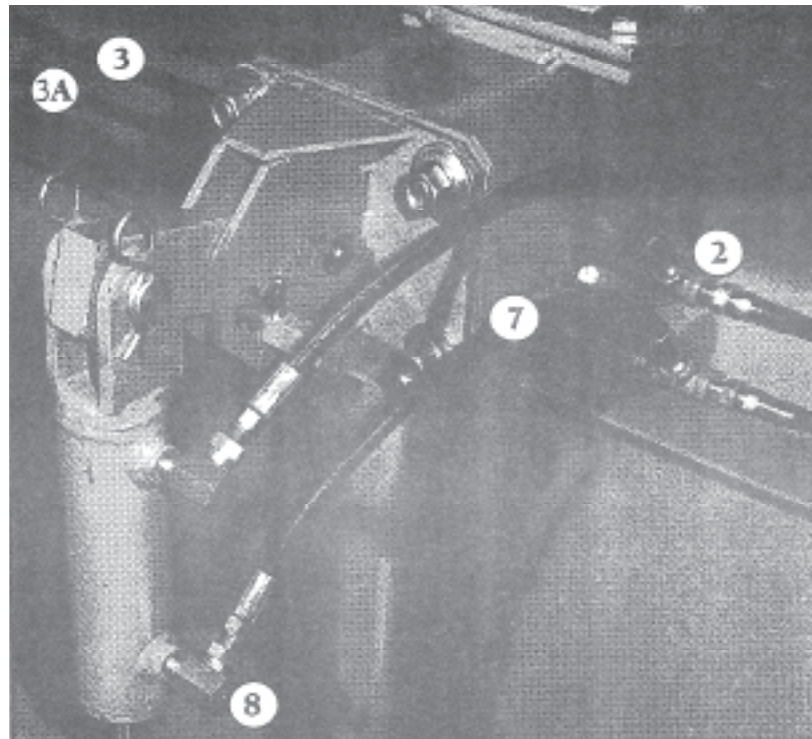
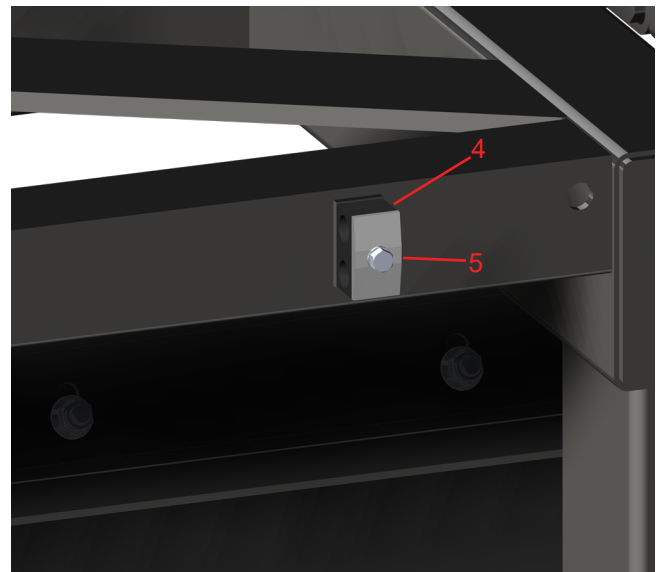
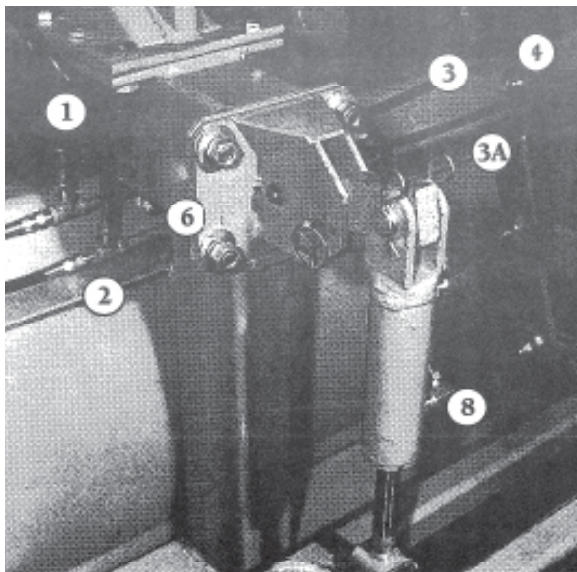

FIG. D

ITEM NO.	DESCRIPTION
1	1/4" x 36" Hose (V180434)
2	1/4" Tee (V623010)
3	1/4" x 112" Hose (V180433)
4	Clamp, Half Plastic (710816)
5	Clamp, Cover Plate (710817)
6	1/4" x 6" Nipple (V625605)
7	18" Hose (V291005)
8	Swivel Fitting (V612024)

FIG. E



## Figures D, E, &amp; F - Hydraulics

1) On the left hand, rear, side of the center section, (Fig. D), connect the 2 - 1/2" x 36" hoses (#1) through 1/4" tees (#2) to 2 - 1/4" x 112" hoses (#3) and (#3A). (For Model 1200 2 - 1/4" x 112" long hoses are connected directly to 1/4" x 90° swivel fitting on cylinder.) (For the 1650, these hoses are 88" long). The outboard ends of the hoses are then connected to the STA cylinder with 1/4", 90°, M-F swivel fittings.



Important - Attach the top lines (#3) to the top ports of all three cylinders, and the bottom lines (#3A) to the bottom ports of the cylinders. The hoses are held in place on the center section and moldboards with hose clamps (#4) and the bolts used to attach the top of the moldboards. A hose mounting bracket, (^5, Fig. F) secures the hoses at the hinge joint to keep them from being pinched when the wings are folded. The hoses are held to the bracket with a hose clamp (^4) and a 1/2" x 1" machine bolt.

2) On the right-hand side of the center section, 1/4" x 6" nipples (#6) are attached to the 1/4" tees, and to the 112" hoses through a second set of 1/4" tees. The outboard ends of the 112" hoses are assembled to the right-hand wing STA cylinder with 1/4" - 90° swivel fittings, again being sure the top hose (^3) leads to the top port of the cylinder, and the bottom hose (#3A) to the bottom port.

3) Two 18" hoses (^7) run from the tees to the center section cylinder (Fig. E) and are attached with 1/4" x 90° swivel fittings.

4) Referring back to Figure C, the tines (^2) can now be mounted on the frame (^1). A 3/8" x 1-1/2" plow bolt attaches the reversible shovel (#4) to the tine, and a 1/2" x 3-1/2" carriage bolt is used to secure the tine and clamp (^3) to the frame. Thoroughly tighten these bolts.

See pages 30, 31, 32, and 33 for proper spacing of tines to avoid interference between the tines and the rear booms.

5) Set the adjustment pins (^10, Fig. B) on the anchor bars to regulate the depth of the tines. The teeth can "float" approximately 2" vertically in operation.

Note: To maintain consistent depth of the three STA frames, STA cylinders must be fully extended during operation. The depth is controlled mechanically - by adjustment of the V180554 pins in the brackets (refer to Figure B, page 26).



**ILLUSTRATED PARTS LIST: V2400-V3000**

WING ASSEMBLY, RIGHT

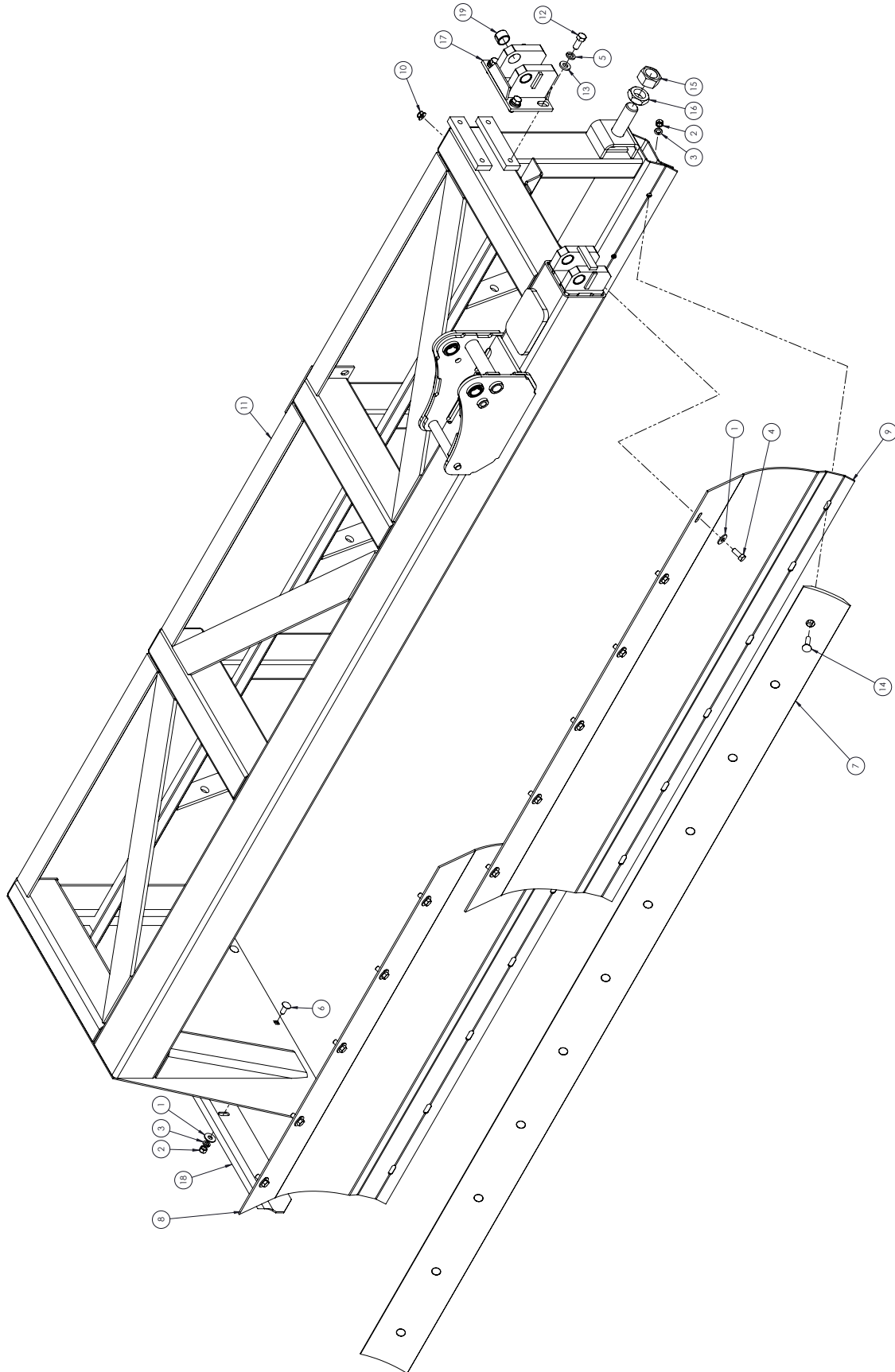



ITEM NO.	PART NUMBER	DESCRIPTION	QTY. 2400	QTY. 3000
1	005200	WASHER, FLAT 1/2 STD	11	14
2	005360	NUT, HEX 1/2-13	11	14
3	005370	WASHER, LOCK 1/2	11	14
4	010730	BOLT, HHCS 1/2-13 X 1-1/4"	8	11
5	020440	WASHER, LOCK 5/8	4	
6	030470	BOLT, CRG 1/2-13 X 1-1/4"	3	
7	599241	CUTTING BIT, WING REV	-	1
	559245	CUTTING BIT, WING REV	1	-
8	599380	MOLDBOARD, WING	-	1
9	599390	MOLDBOARD, WING	-	1
8 & 9	599385	MOLDBOARD, WING	1	-
10	600140	NUT, HFH NYLOC 1/2-13	8	11
11	661320	FRAME WLDT, RH WING	-	1
	661430	FRAME WLDT, RH WING	1	-
12	990610	BOLT, HHCS 5/8-11 X 1-1/2"	4	
13	I25547R1	WASHER, FLAT 21/32 X 1-5/16 PHC	4	
14	V059779	BOLT, PLOW 1/2-13 X 2	8	11
15	V061946	NUT, HEX 1-1/2-6 GR5 ZN	1	
16	V062146	NUT, JAM 1 1/2-6 HEX ZN	1	
17	V180138	HINGE, ADJUSTABLE	1	
18	V180253	PLATE, HF WEAR	1	
19	V180258	BUSHING, TENSION	4	

WING ASSEMBLY, LEFT

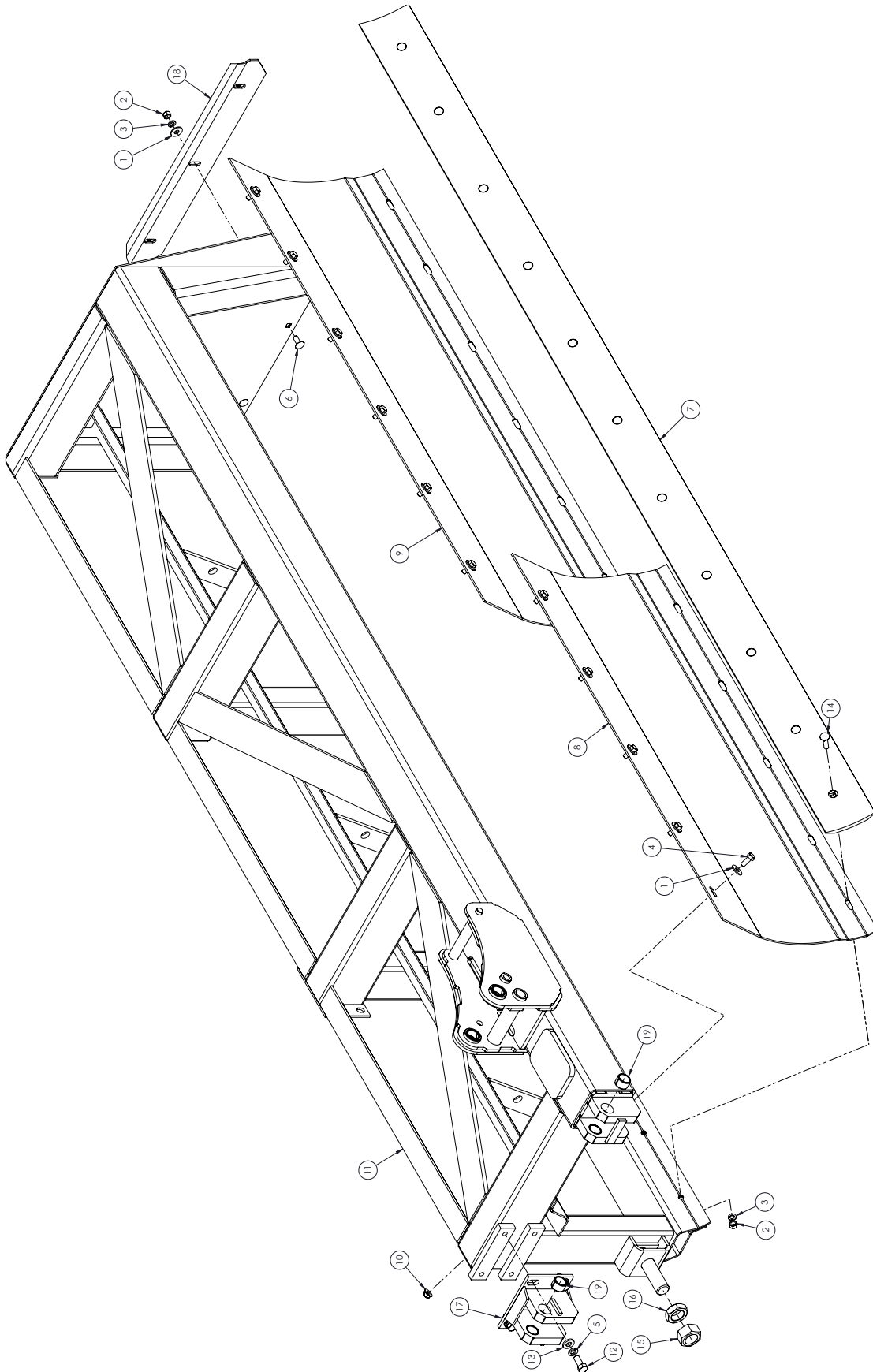

ITEM NO.	PART NUMBER	DESCRIPTION	QTY. 2400	QTY. 3000
1	005200	WASHER, FLAT 1/2 STD	11	14
2	005360	NUT, HEX 1/2-13	11	14
3	005370	WASHER, LOCK 1/2	11	14
4	010730	BOLT, HHCS 1/2-13 X 1-1/4"	8	11
5	020440	WASHER, LOCK 5/8	4	
6	030470	BOLT, CRG 1/2-13 X 1-1/4"	3	
7	599241	CUTTING BIT, WING REV	-	1
	559245	CUTTING BIT, WING REV	1	-
8	599380	MOLDBOARD, WING	-	1
9	599390	MOLDBOARD, WING	-	1
8 & 9	599385	MOLDBOARD, WING	1	-
10	600140	NUT, HFH NYLOC 1/2-13	8	11
11	661330	FRAME WLDT, LH WING	-	1
	661440	FRAME WLDT, LH WING	1	-
12	990610	BOLT, HHCS 5/8-11 X 1-1/2"	4	
13	I25547R1	WASHER, FLAT 21/32 X 1-5/16 PHC	4	
14	V059779	BOLT, PLOW 1/2-13 X 2	8	11
15	V061946	NUT, HEX 1-1/2-6 GR5 ZN	1	
16	V062146	NUT, JAM 1 1/2-6 HEX ZN	1	
17	V180138	HINGE, ADJUSTABLE	1	
18	V180253	PLATE, HF WEAR	1	
19	V180258	BUSHING, TENSION	4	

### MOLDBOARD ASSEMBLY, CENTER

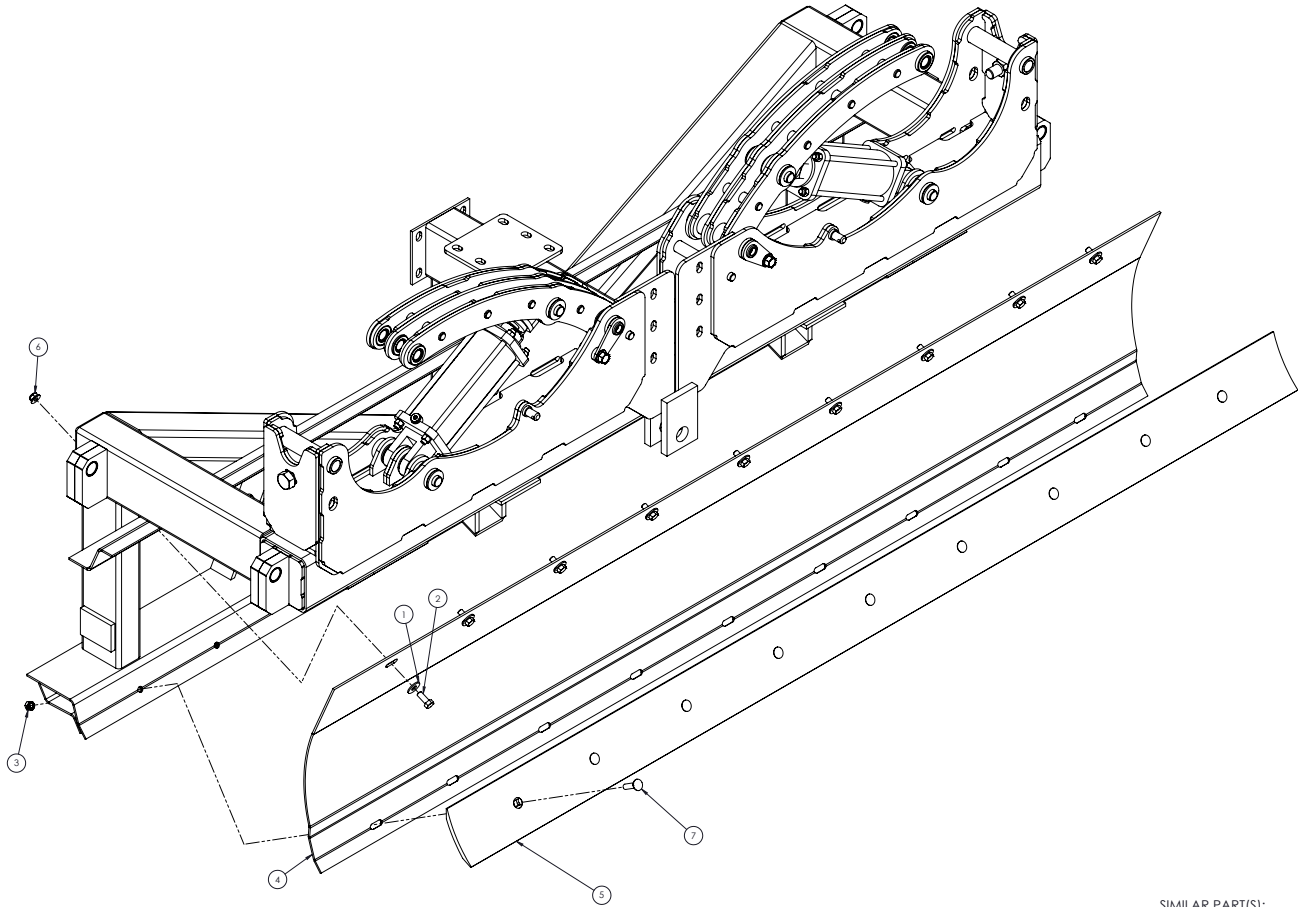

ITEM NO.	PART NUMBER	DESCRIPTION	QTY.
1	005200	WASHER, FLAT 1/2 STD	9
2	010730	BOLT, HHCS 1/2-13 X 1-1/4"	9
3	127890	NUT, LOCK 1/2-13	9
4	599220	MOLDBOARD, CENTER	1
5	599231	CUTTING BIT, CENTER REV	1
6	600140	NUT, HFH NYLOC 1/2-13	9
7	V059779	BOLT, PLOW 1/2-13 X 2	9

WING LIFT ASSEMBLY

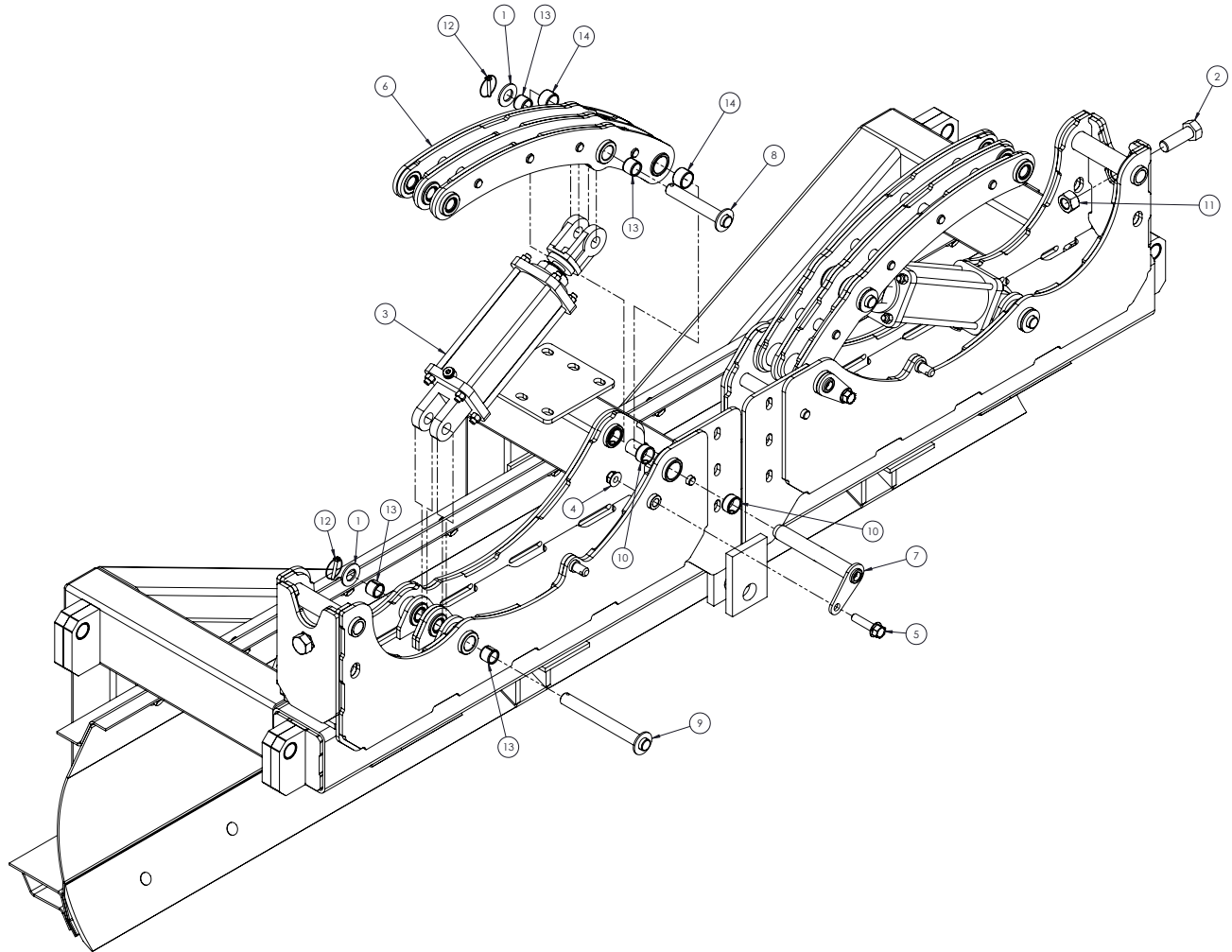

ITEM NO.	PART NUMBER	DESCRIPTION	QTY.
1	1107389	WASHER, FLAT 1 SAE	4
2	497590	BOLT, HHCS 1-8 X 3 GR8	2
3	561940	CYLINDER, HYD 4 X 8	2
4	600150	NUT, HFH NYLOC 5/8-11	2
5	600310	BOLT, HFH 5/8-11 X 2-1/2"	2
6	661230	LIFT ARM WELDMENT	2
7	661250	PIN WELDMENT	2
8	661255	PIN, 1" X 6-1/4"	2
9	661260	PIN, 1" X 9"	2
10	I1268053C1	BUSHING, STEEL	8
11	J14H805	NUT, HEX 1-8	2
12	R66461	1/4" LYNCH PIN	4
13	V180220	BUSHING, STEEL	26
14	V180258	BUSHING, TENSION	4

**WING CONNECTION ASSEMBLY**

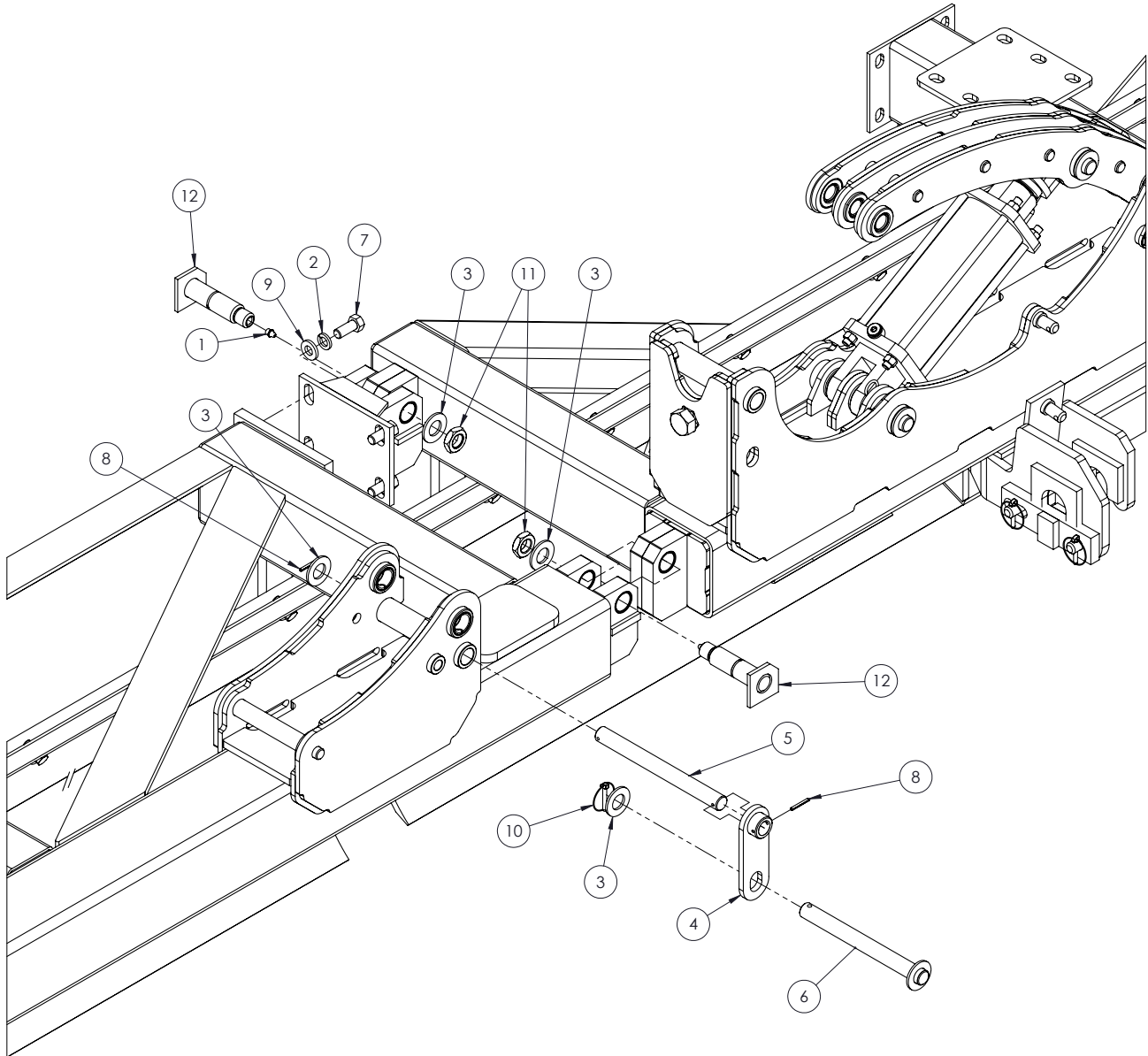

ITEM NO.	PART NUMBER	DESCRIPTION	QTY.
1	013170	FITTING, GREASE STRAIGHT	4
2	020440	WASHER, LOCK 5/8	8
3	1107389	WASHER, FLAT 1 SAE	8
4	661245	WING LOCK WELDMENT	2
5	661266	PIN, WING LOCK	2
6	661285	PIN, LOCK SELECTOR	2
7	990610	BOLT, HHCS 5/8-11 X 1-1/2"	8
8	E580205	PIN, ROLL 3/16 X 1-3/4	4
9	I25547R1	WASHER, FLAT 21/32 X 1-5/16 PHC	8
10	R66461	1/4" LYNCH PIN	2
11	V066513	NUT, JAM 1-14	4
12	V180642	JP ASSEMBLY	4

HITCH ATTACH ASSEMBLY

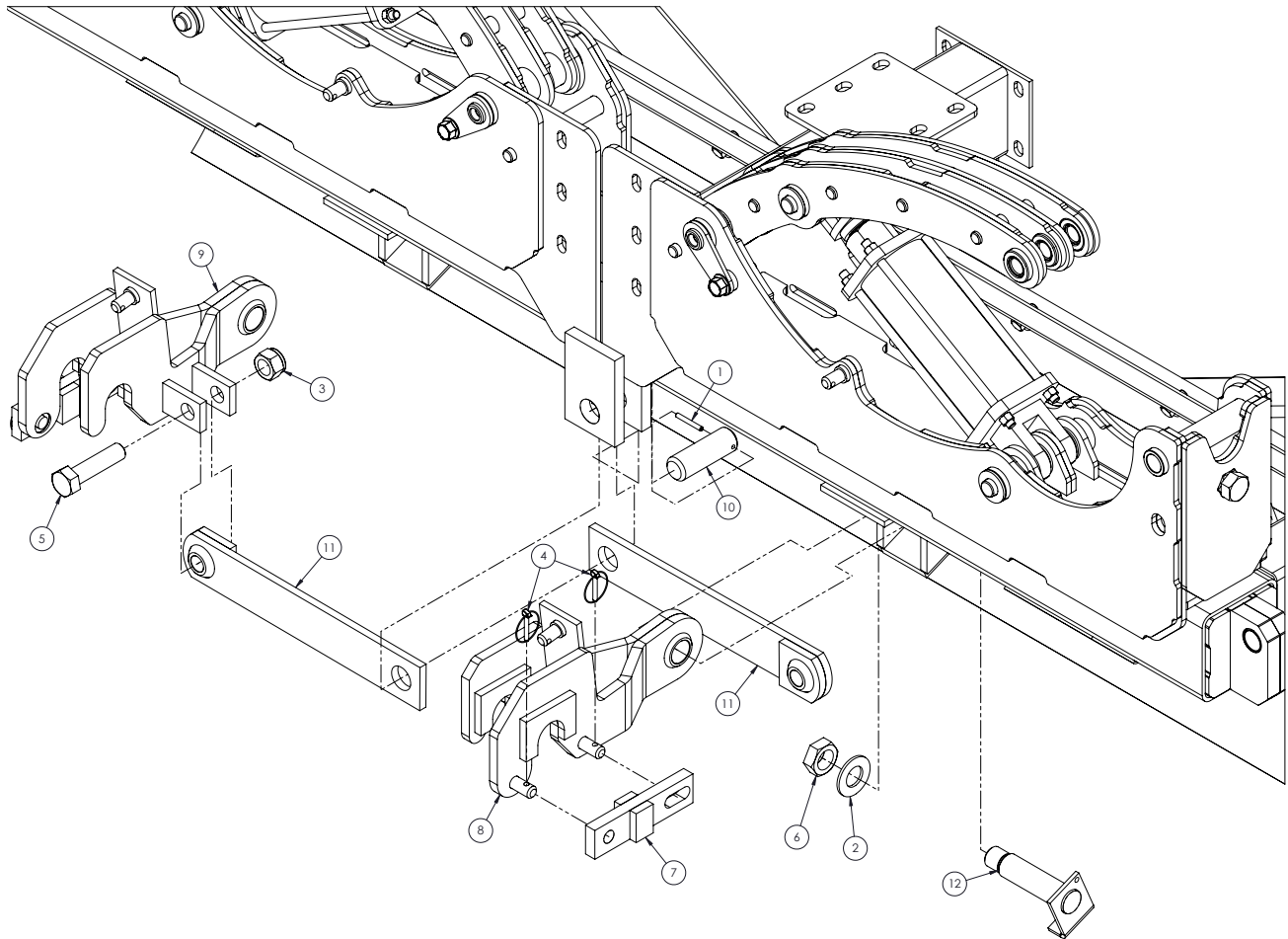

ITEM NO.	PART NUMBER	DESCRIPTION	QTY.
1	013600	PIN, ROLL .25 X 2	1
2	E829022	WASHER, FLAT 1-1/4" SAE	2
3	MP09.70791	NYLON INSERT LOCKNUT, 1-8 UNC	2
4	R66461	1/4" LYNCH PIN	4
5	V055634	HBOLT 1.00-8X4 GR5	2
6	V066516	NUT, JAM 1-1/4-12	2
7	V180366	BAR WLDT	2
8	V180375	PLATE WLDT,	1
9	V180376	PLATE WLDT,	1
10	V180377	PIN CTR	1
11	V180378	WLDT, CROSS LINK	2
12	V180429	WLTD, HITCH PLATE MTG, PIN	2

**TURNBUCKLE LEFT/RIGHT ASSEMBLY**

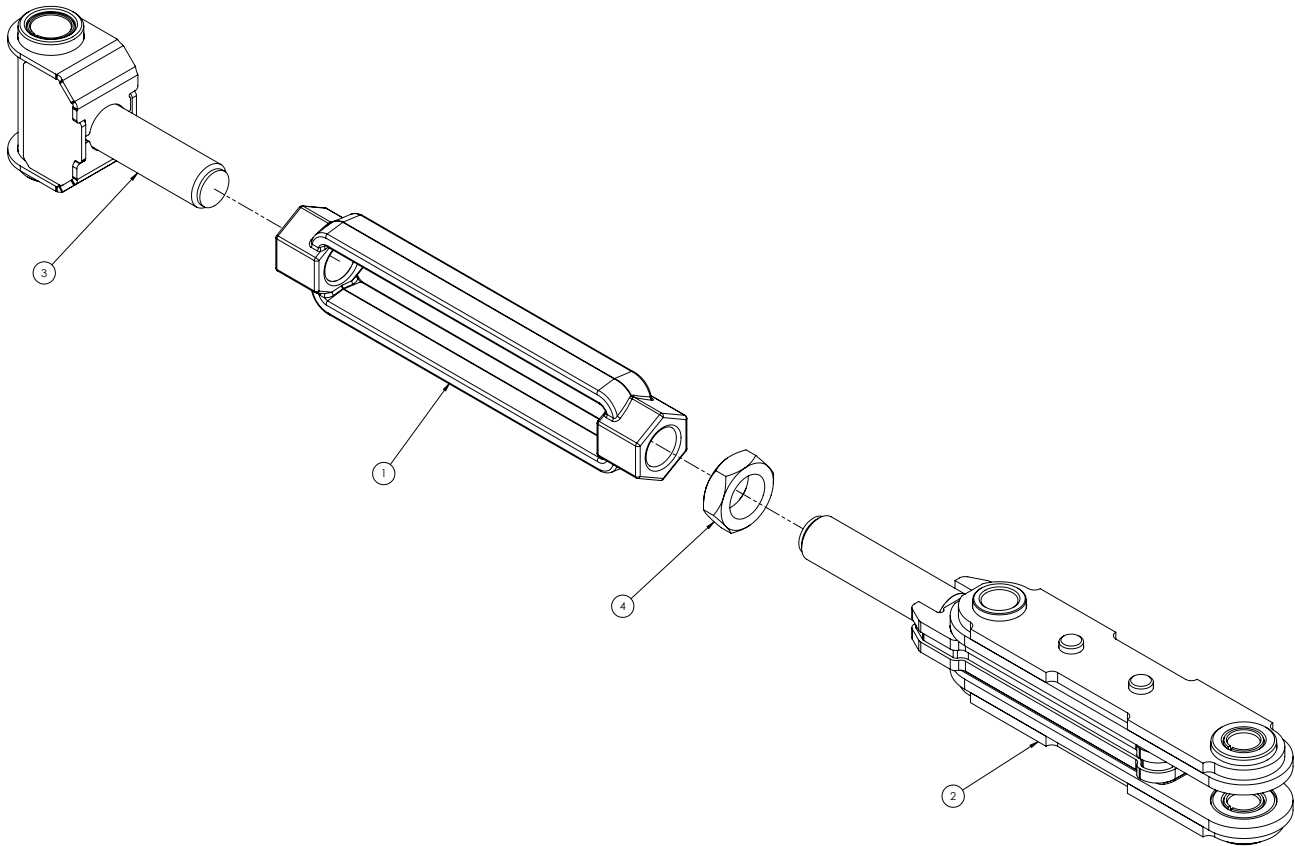

ITEM NO.	PART NUMBER	DESCRIPTION	QTY.
1	599210	TURNBUCKLE	1
2	661225	CLEVIS WELDMENT	1
3	661265	LINK END WELDMENT	1
4	V062146	NUT, JAM 1 1/2-6 HEX ZN	1



TURNBUCKLE ASSEMBLY

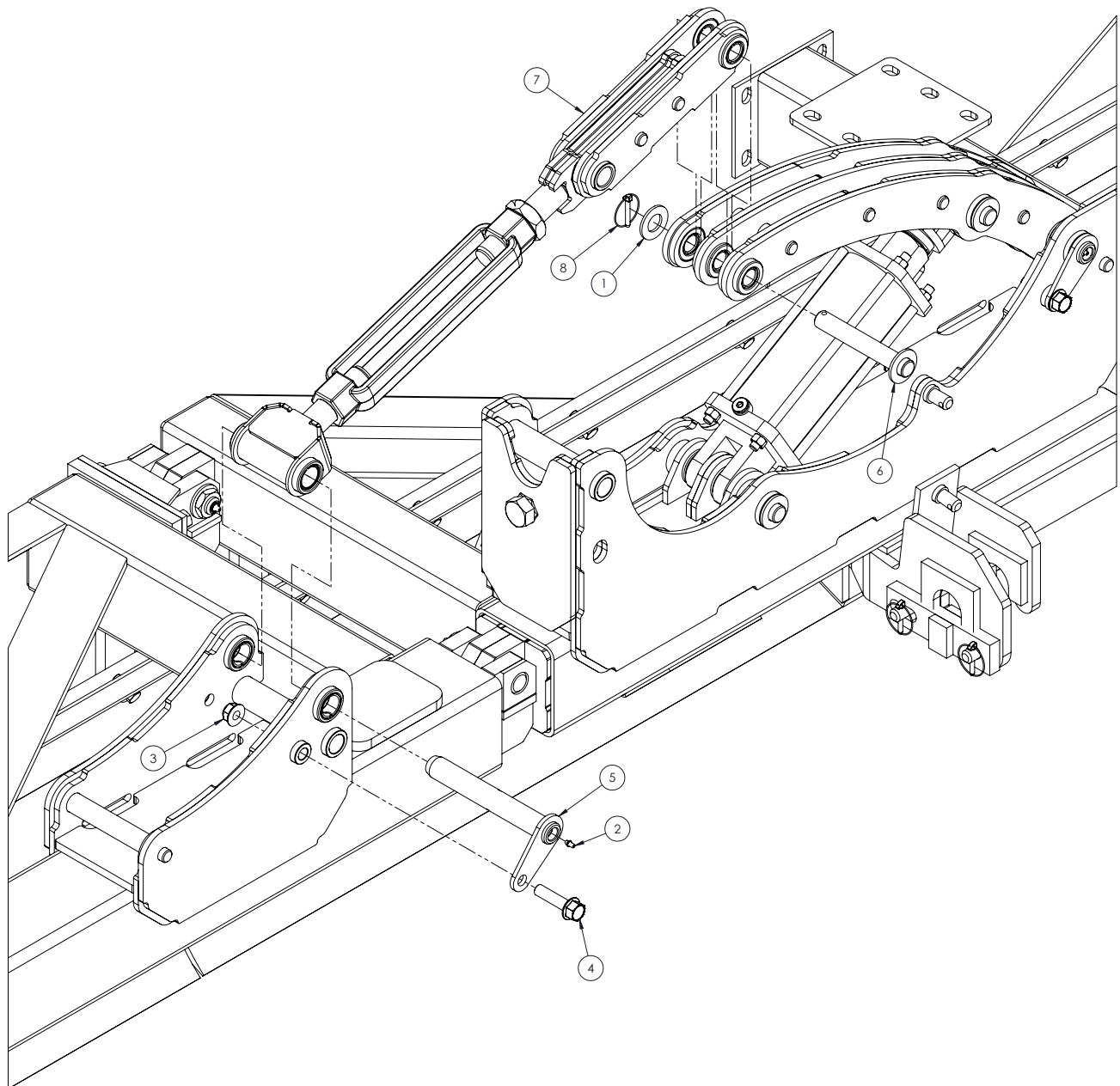

ITEM NO.	PART NUMBER	DESCRIPTION	QTY.
1	1107389	WASHER, FLAT 1 SAE	2
2	115590	FITTING, GREASE	4
3	600150	NUT, HFH NYLOC 5/8-11	2
4	600310	BOLT, HFH 5/8-11 X 2-1/2"	2
5	661250	PIN WELDMENT	2
6	661255	PIN, 1" X 6-1/4"	2
7	661270	TURNBUCKLE ASSEMBLY	2
8	R66461	1/4" LYNCH PIN	2

**BOOM ASSEMBLY**

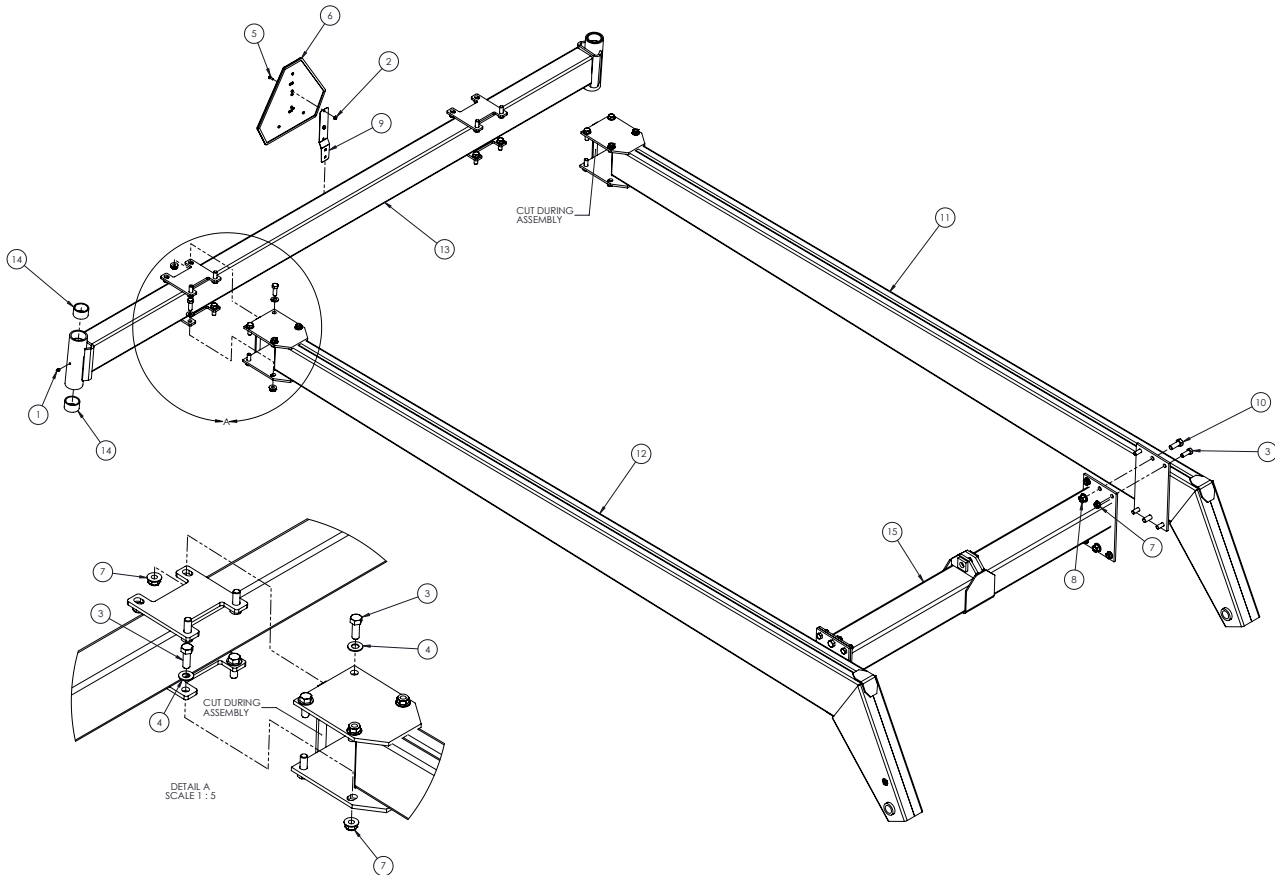

ITEM NO.	PART NUMBER	DESCRIPTION	QTY.
1	013170	FITTING, GREASE STRAIGHT	2
2	023270	NUT, LOCK 1/4-20 FLG	2
3	025100	BOLT, HHCS 5/8-11 X 1-3/4"	24
4	035210	WASHER, FLAT 5/8	16
5	035230	SCREW, THMS 1/4-20	2
6	467450	DECAL, WARNING MOVING	1
7	600150	NUT, HFH NYLOC 5/8-11	24
8	600160	NUT, HFH TOPLOCK 3/4-10	4
9	E104471	BRACKET	1
10	V061704	HBOLT 0.7500-10X2.5X2.5-N	4
11	V180167	BOOM WLDT LH	1
12	V180168	BOOM WLDT RH	1
13	V180186	CROSS WLDT,	1
14	V180256	BEARING, BRONZE	4
15	V180455	WLDT, FRONT	1

**MAST ASSEMBLY, FRAME**

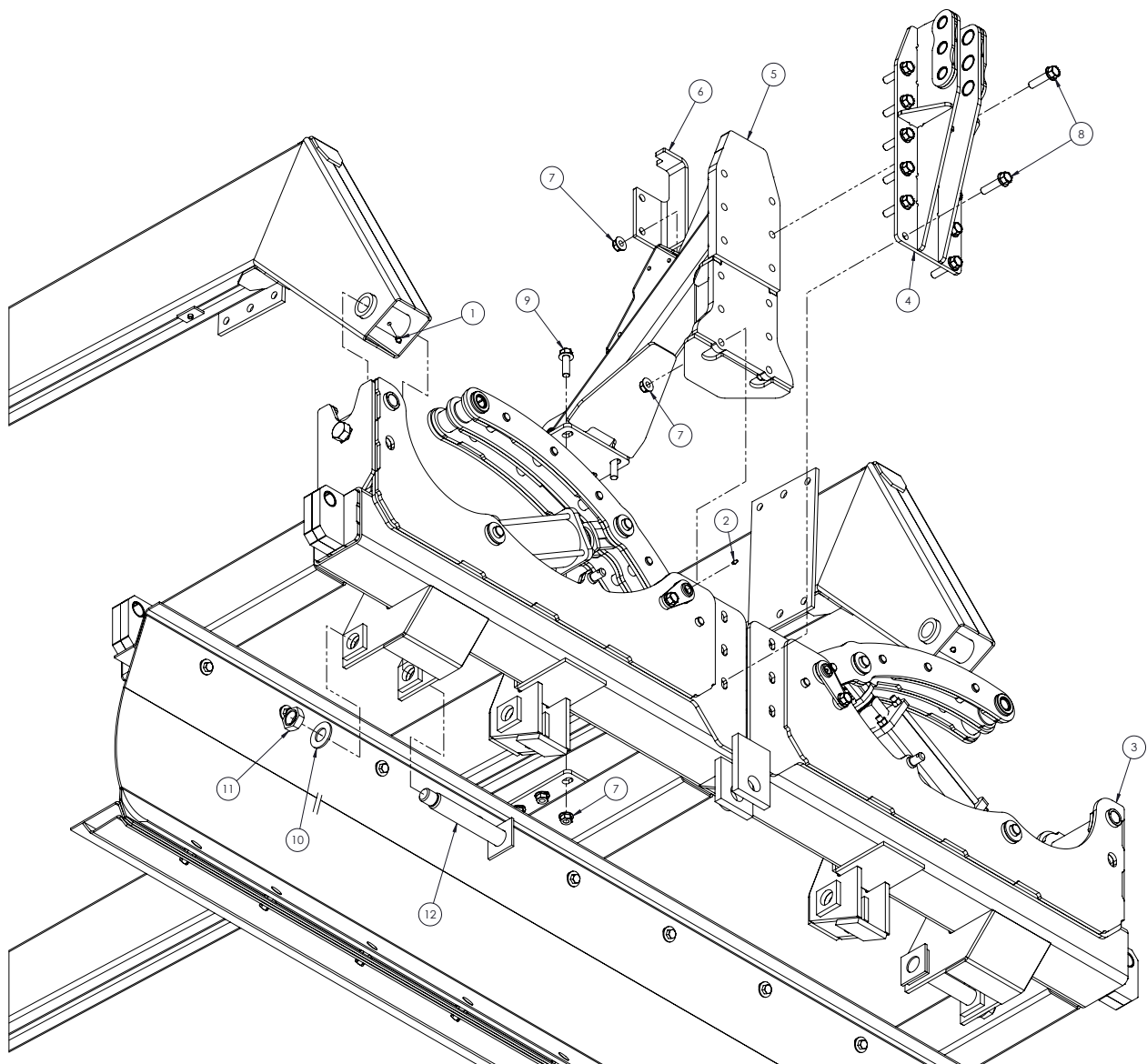

ITEM NO.	PART NUMBER	DESCRIPTION	QTY.
1	013170	FITTING, GREASE STRAIGHT	2
2	115590	FITTING, GREASE	2
3	530210	FITTING, HYD 90 -8M JIC X -8M ORB	1
4	599023	MOUNT, TOP LINK	1
5	599025	CYLINDER MOUNT WLDT	1
6	599027	HOSE MOUNT	1
7	600150	NUT, HFH NYLOC 5/8-11	18
8	600310	BOLT, HFH 5/8-11 X 2-1/2"	12
9	600540	BOLT, HFH 5/8-11 X 2"	6
10	E829022	WASHER, FLAT 1-1/4" SAE	2
11	V066516	NUT, JAM 1-1/4-12	2
12	V180243	WLDT, BOOM PIN	2

CENTER LIFT ASSEMBLY

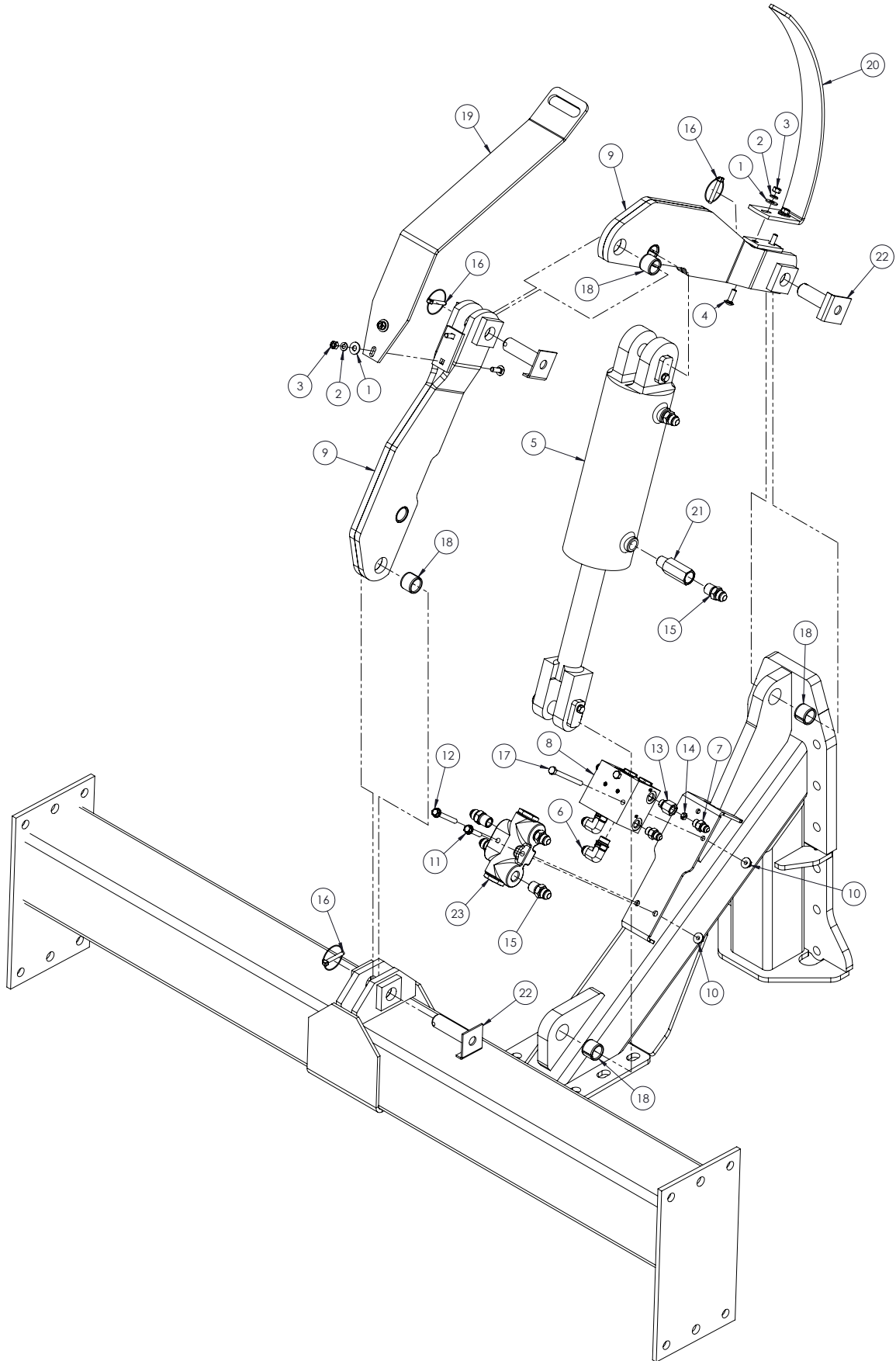

ITEM NO.	PART NUMBER	DESCRIPTION	QTY.
1	022920	WASHER, FLAT 5/16 STD	4
2	023620	WASHER, LOCK 5/16	4
3	023630	NUT, HEX 5/16-18	4
4	254060	BOLT, CRG 5/16-18 X 1"	4
5	510640	CYLINDER, HYD	1
6	530210	FITTING, HYD 90°	2
7	530240	STRAIGHT -6M JIC X -6M ORB	4
8	563000	VALVE ASSY, DUAL CHECK	1
9	569830	ARM ASSY,	2
10	600110	NUT, HFH NYLOC 5/16-18	4
11	600250	BOLT, HFH 5/16-18 X 1.50	1
12	600275	BOLT, HFH 5/16-18	1
13	605825	FITTING, HYD ORF ADAPTER	2
14	605826	FITTING, HDY ORF PLATE	2
15	637030	FITTING, HYD STRAIGHT	6
16	R66461	1/4" LYNCH PIN	3
17	V054934	BOLT, HHCS 5/16-18 X 3-3/4"	2
18	V180220	BUSHING, STEEL	6
19	V180542	STRIP, GAUGE	1
20	V180543	STRIP, GAUGE DECAL	1
21	V180624	VALVE, HYD RESTRICTOR	1
22	V180647	WLDT, CLEVIS PIN	3
23	V308250	VALVE ASSY, DUAL CHECK	1

**HITCH ASSEMBLY, QUICK ATTACH 558000**

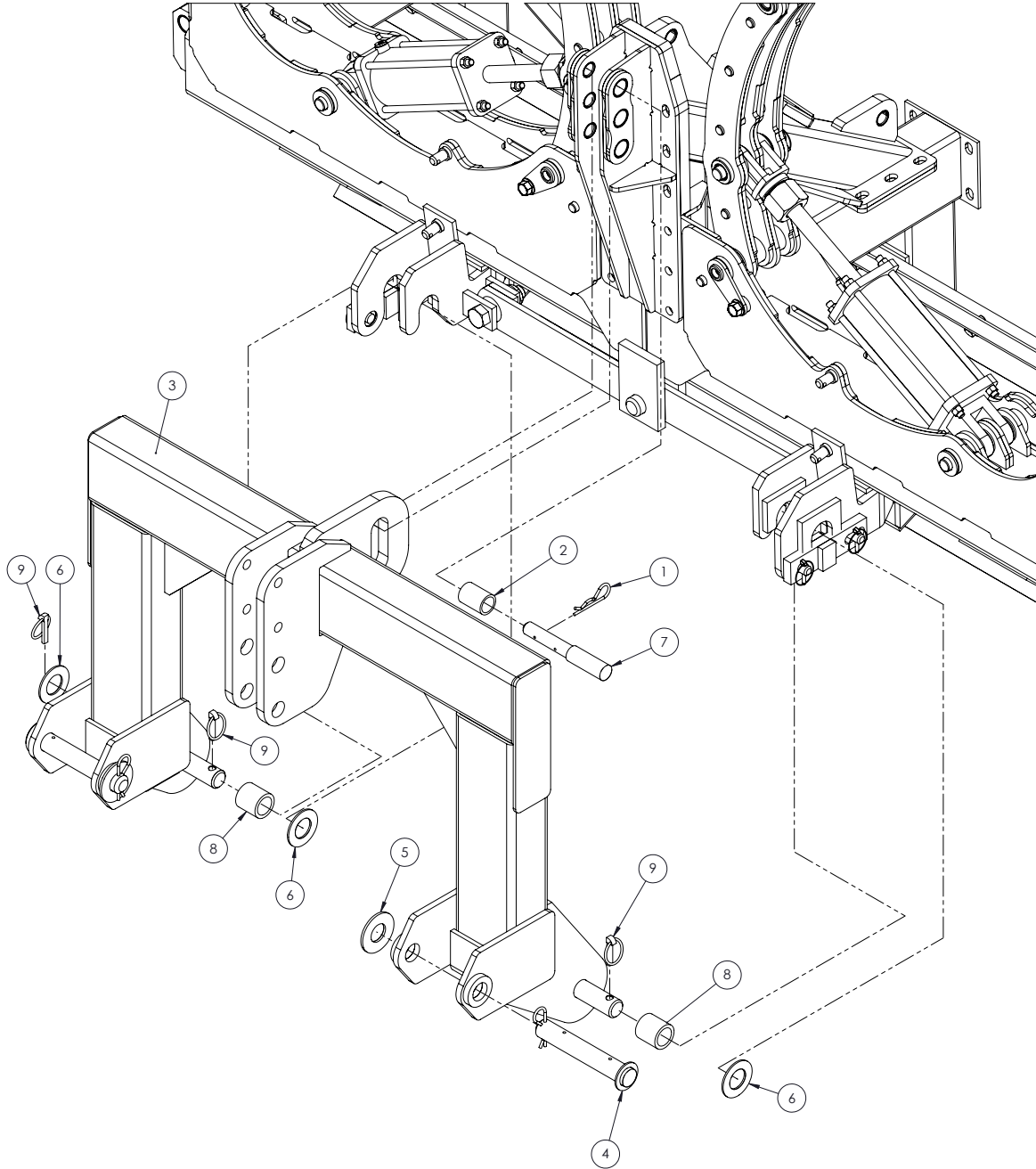

ITEM NO.	PART NUMBER	DESCRIPTION	QTY.
1	035830	PIN, COTTER 3/16 X 1-1/2 ZN	3
2	557990	BUSHING 1.63 OD X	1
3	558010	QUICK HITCH WLDT,	1
4	558060	PIN WLDT, LOWER	2
5	R61502	WASHER,FLAT 1-3/8" STD	2
6	V063596	WASHER, FLAT 1-1/2 SAE ZN	4
7	V180631	PIN, STEP UPPER	1
8	V180664	SLEEVE, OUTER	4
9	V240437	LYNCH PIN, 7/16X2	4

ASSEMBLY, CATEGORY 3 V180580

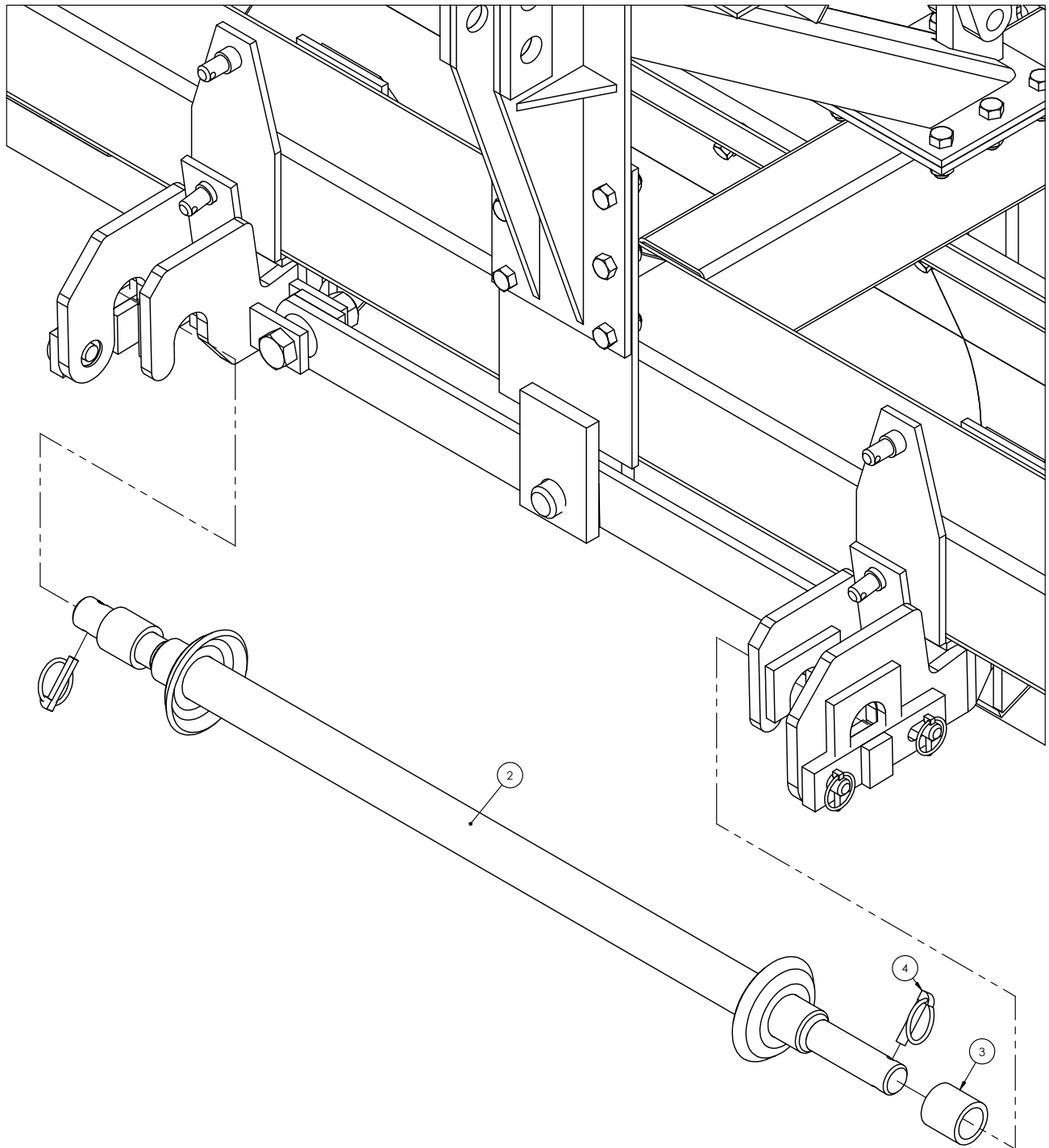

ITEM NO.	PART NUMBER	DESCRIPTION	QTY.
1	V180720	KIT CAT 3, HITCH BAR	1
2	V180799	HITCH BAR WLDMNT.	1
3	V180664	SLEEVE, OUTER	2
4	V240437	LYNCH PIN, 7/16X2	2

HITCH ASSEMBLY, CATEGORY 4N V180585

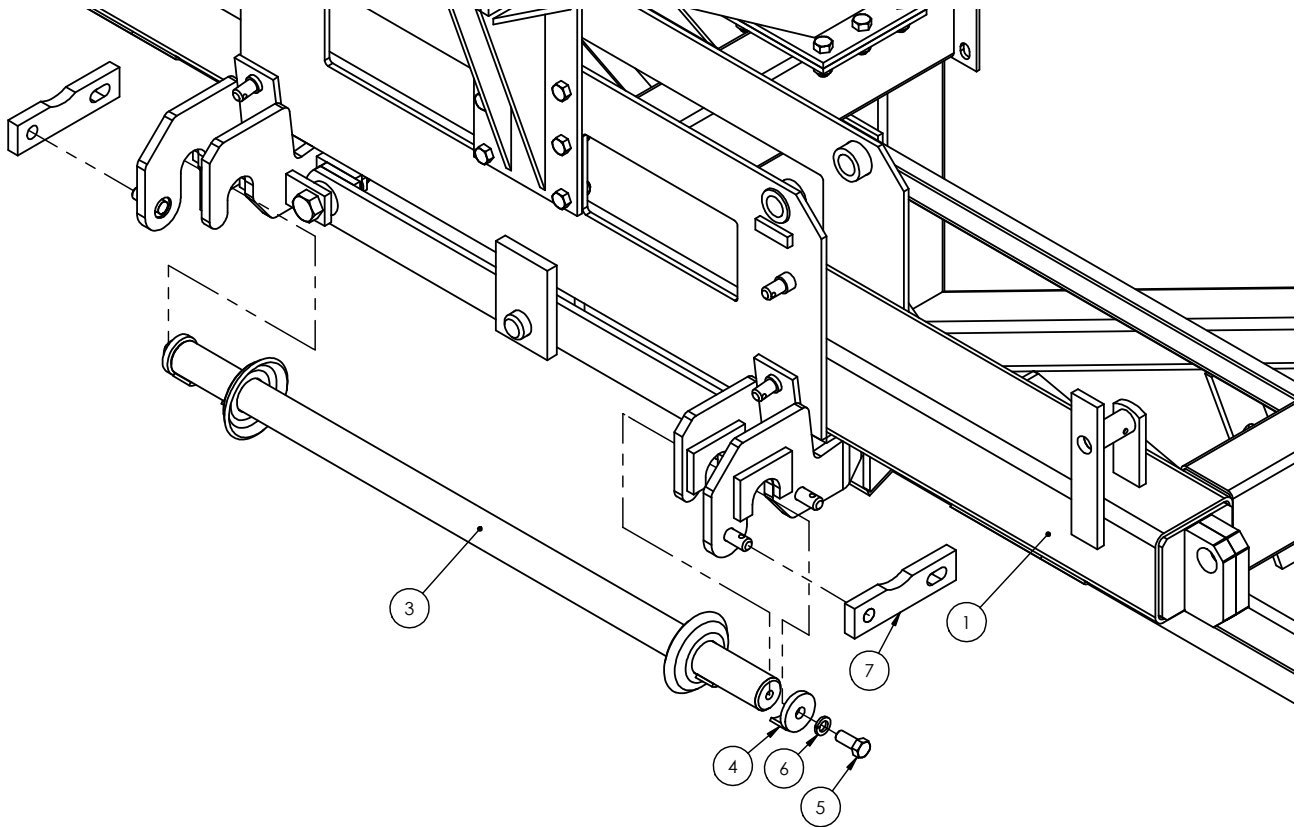

ITEM NO.	PART NUMBER	DESCRIPTION	QTY.
1	599010	FRAME WLDT, CENTER	1
2	V180585	KIT, CAT 4N HITCH	1
3	V180586	WDLT, HITCH BAR	1
4	V180636	CAP WDLT,	2
5	990610	BOLT, HHCS 5/8-11 X 1 1/2 GR5 ZN	2
6	020440	WASHER, LOCK 5/8	2
7	V180659	BAR, CAT 4N	2



S-TINE ASSEMBLY, CENTER TO FRAME

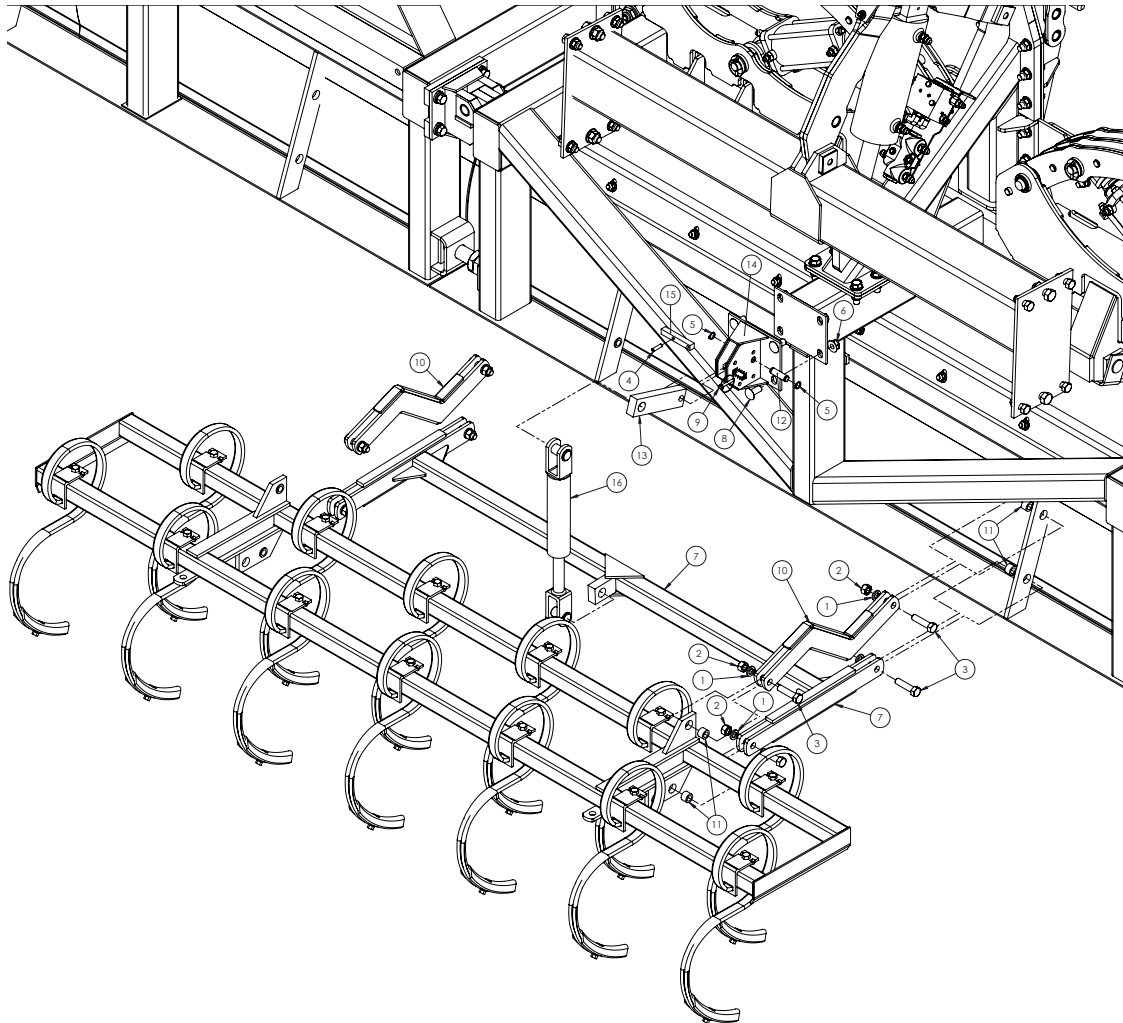

ITEM NO.	PART NUMBER	DESCRIPTION	QTY. 2400	QTY. 3000
1	020440	WASHER, LOCK 5/8		8
2	020450	NUT, HEX 5/8-11		8
3	023110	BOLT, HHCS 5/8-11 X 2-1/2		8
4	1030808	PIN, 5/16 X 1-1/4		1
5	1040970	RING, RETAINING EXTERNAL 5/8		2
6	600150	NUT, HFH NYLOC 5/8-11		4
7	605630	LIFT LINK WLDT,		1
8	I467657R1	BOLT, CRG 5/8-11		4
9	R66461	1/4" LYNCH PIN		1
10	V180318	OFFSET PARALLEL LINK		2
11	V180330	BUSHING 5/8 ID X 1 OD X 11/16 LG		8
12	V180391	PIN, STA PIVOT		1
13	V180553	BAR, CYL. ANCHOR STA		1
14	V180557	WLDT, STA CYL ADJ		1
15	V180640	PIN, CYL. ANCHOR ADJ		1
16	V180910	CYLINDER, HYD.		1

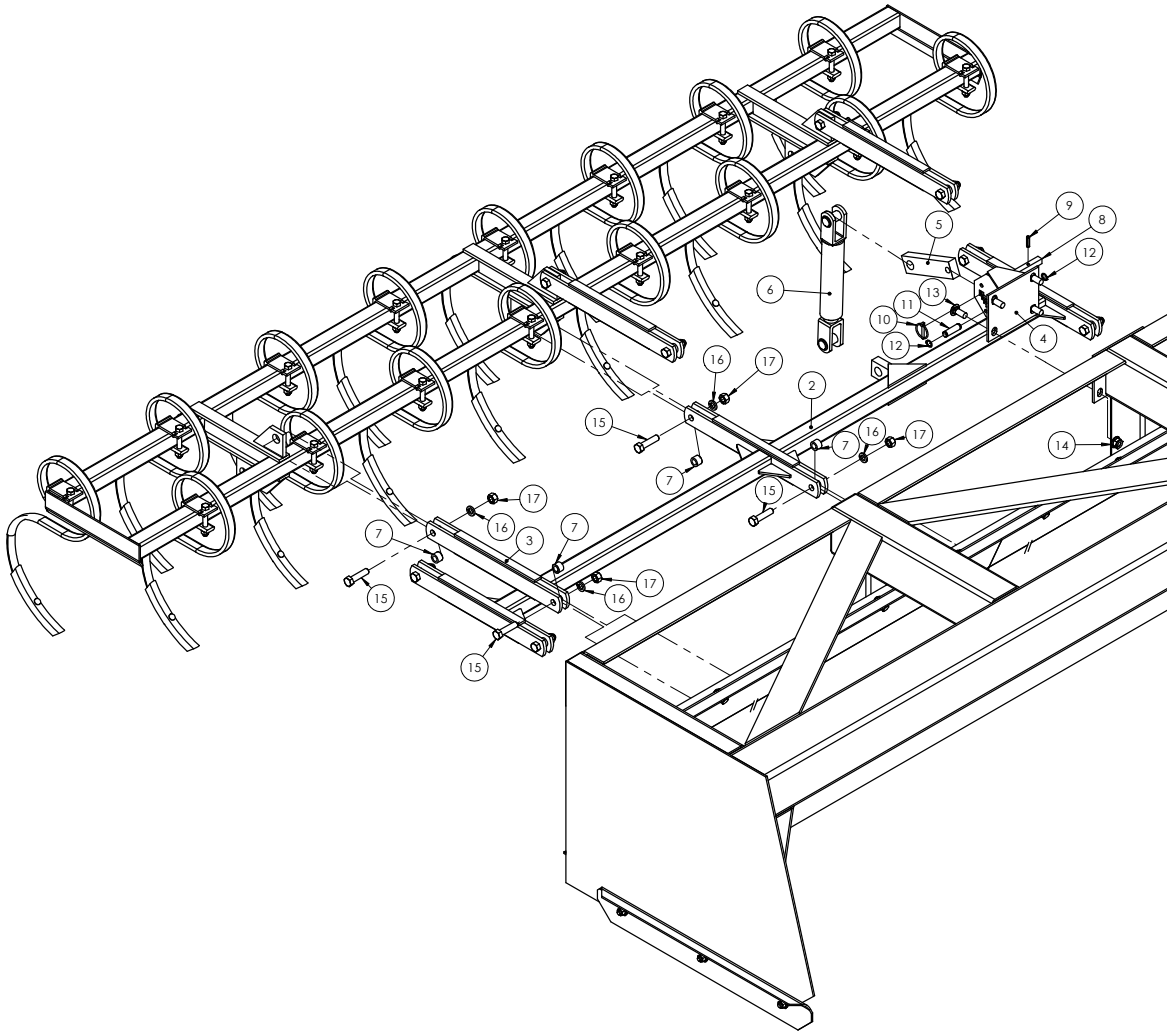
**S-TINE ASSEMBLY, RIGHT/LEFT TO FRAME**

ITEM NO.	PART NUMBER	DESCRIPTION	QTY. 2400	QTY. 3000
2	605610	LIFT LINK WLDT, WING		2
3	V180306	MOUNTING ARM,		8
4	V180557	WLDT, STA CYL ADJ		3
5	V180553	BAR, CYL. ANCHOR STA		3
6	V180910	CYLINDER, HYD.		3
7	V180330	BUSHING 5/8 ID X 1 OD X 11/16 LG		32
8	V180640	PIN, CYL. ANCHOR ADJ		3
9	1030808	PIN, 5/16 X 1-1/4		3
10	R66461	PIN, SNAP-RING		3
11	V180391	PIN, STA PIVOT		3
12	1040970	RING, RETAINING EXTERNAL 5/8		6
13	I467657R1	BOLT, CRG 5/8-11 X 2-1/4 GR5 ZN		12
14	600150	NUT, HFH NYLOC		12
15	023110	HHCS 5/8-11 X 2.5 GR5 ZN		32
16	020440	WASHER, LOCK 5/8		32
17	020450	NUT, HEX 5/8-11		32

S-TINE ASSEMBLY, RIGHT/LEFT TO FRAME

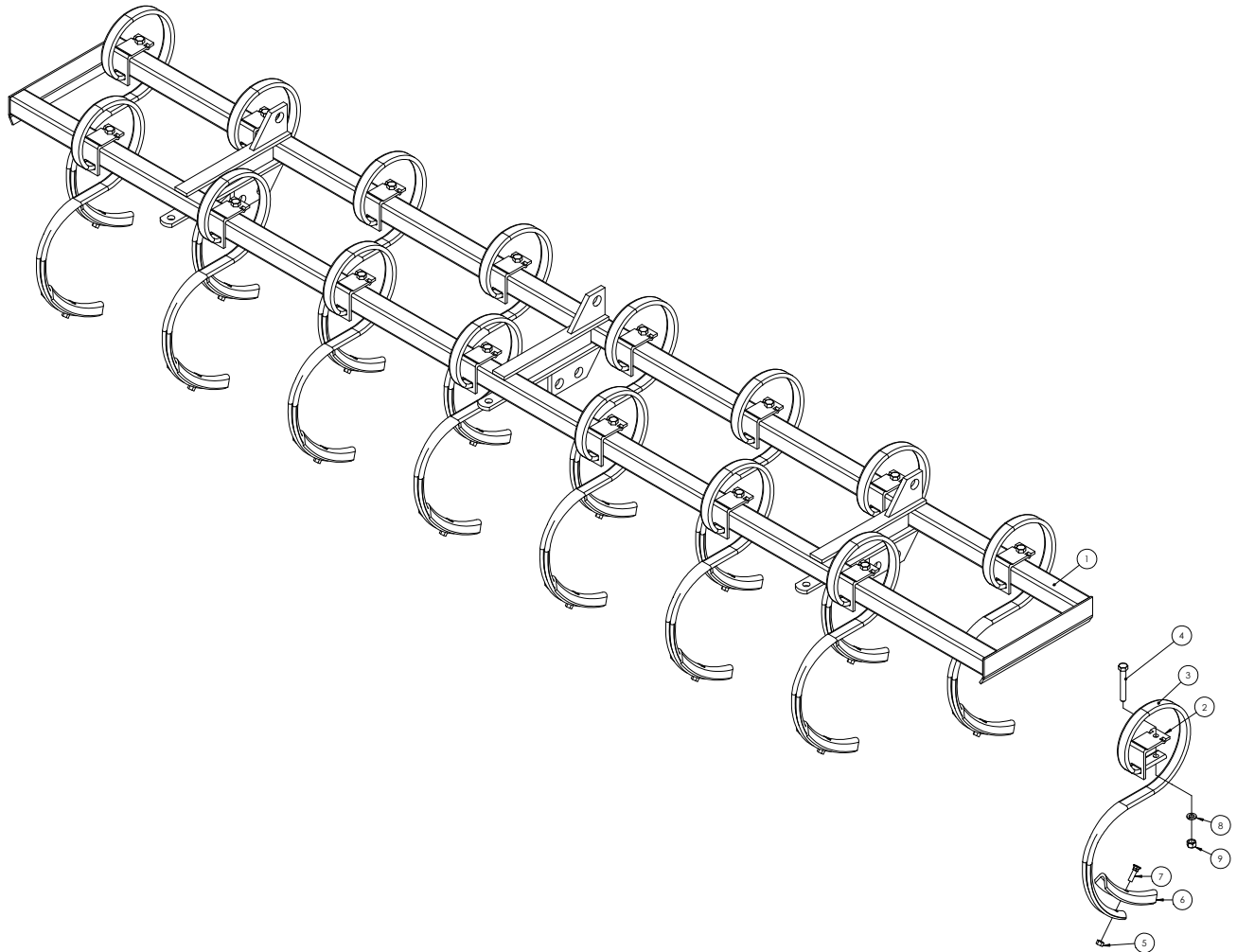

ITEM NO.	PART NUMBER	DESCRIPTION	QTY. 2400	QTY. 3000
1	605670	FRAME WLDT, RIGHT/LEFT		1
2	V180425	CLAMP, S-TINE		16
3	V180423	S-TINE		16
4	1770608	HHCS, 1/2-13 X 3.25, G5, ZN		16
5	027260	NUT, HEX 3/8-16 GR5 ZN		16
6	V180424	POINT		16
7	V059779	BOLT, PLOW 1/2-13 X 2		16
8	005370	WASHER, LOCK 1/2 ZN		16
9	005360	NUT, HEX, 1/2" Z5		16

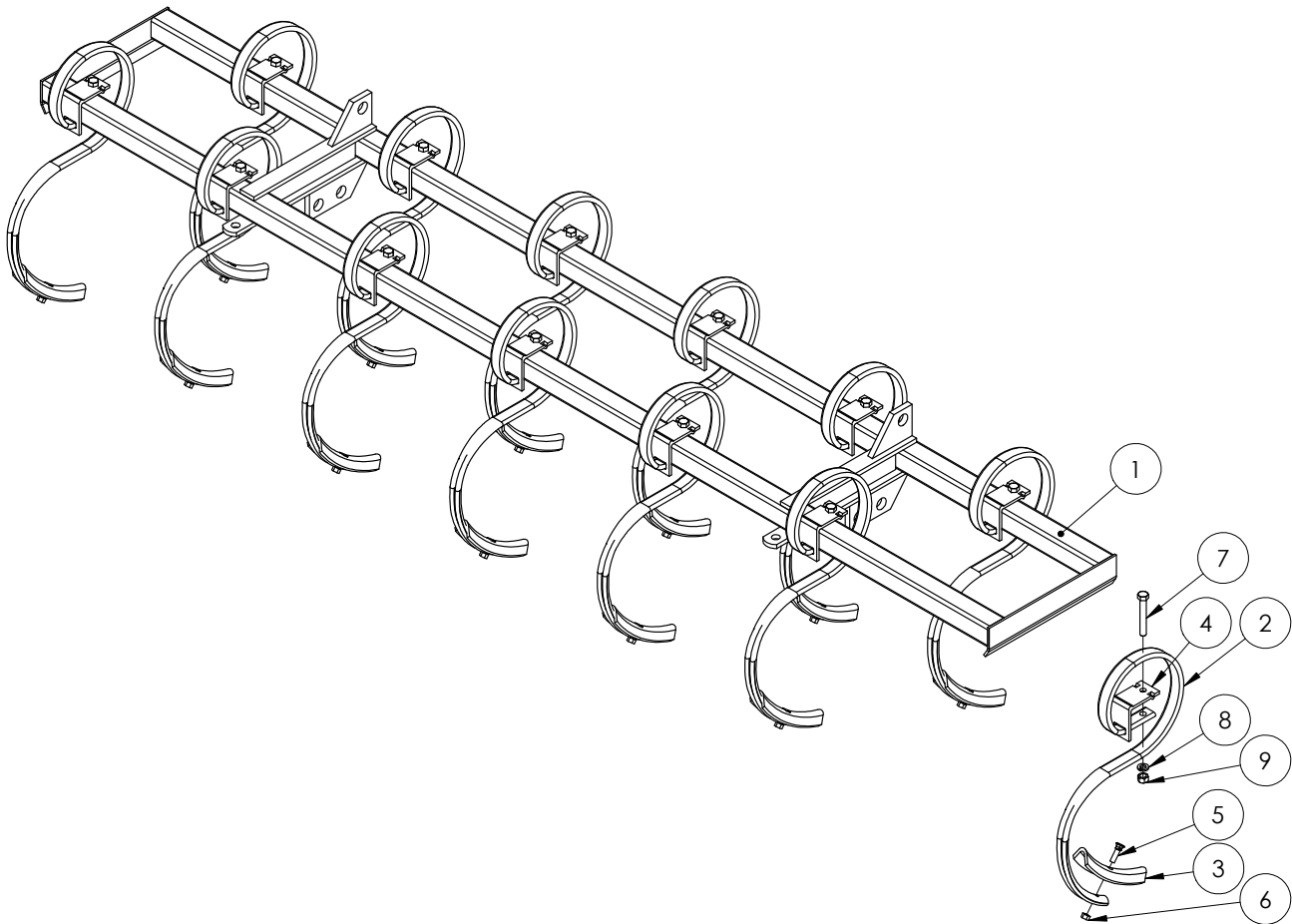
**S-TINE ASSEMBLY, CENTER TO FRAME**

ITEM NO.	PART NUMBER	DESCRIPTION	QTY. 2400	QTY. 3000
1	605650	FRAME WLDT, CENTER		1
2	V180423	S-TINE		13
3	V180424	POINT		13
4	V180425	CLAMP, S-TINE		13
5	V059779	BOLT, PLOW 1/2-13 X 2		13
6	027260	NUT, HEX 3/8-16 GR5 ZN		13
7	1770608	HHCS, 1/2-13 X 3.25, G5, ZN		13
8	005370	WASHER, LOCK 1/2 ZN		13
9	005360	NUT, HEX, 1/2" Z5		13

**SINGLE WHEEL ASSEMBLY**

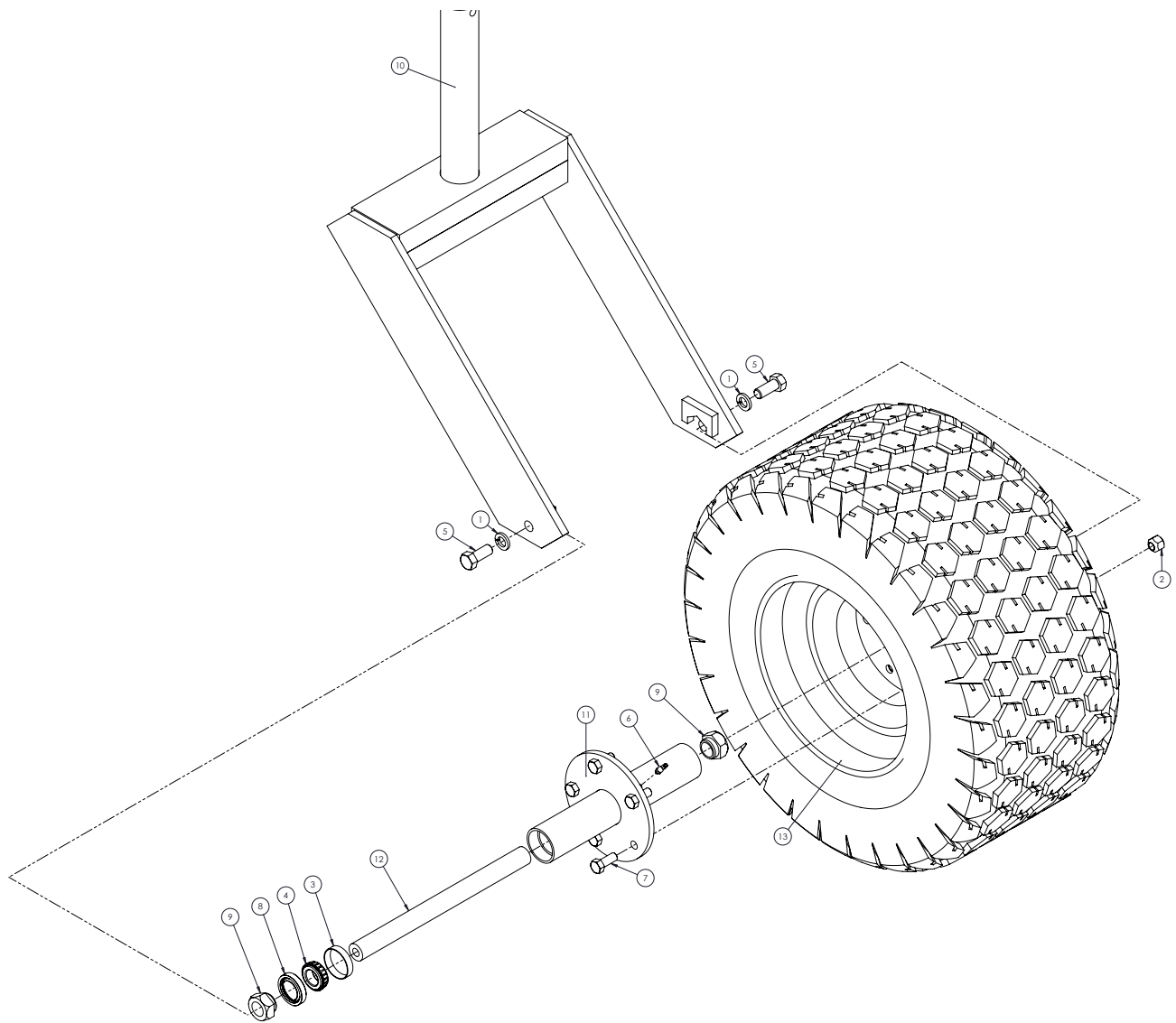

ITEM NO.	PART NUMBER	DESCRIPTION	QTY.
1	020440	WASHER, LOCK 5/8	2
2	020730	HTNUT 0.5000-20-D-N	5
3	169920	BEARING, CUP	2
4	169930	BEARING CONE	2
5	990610	BOLT, HHCS 5/8-11 X 1-1/2"	2
6	V006005	FITTING, 1/8 NPT 45 DEGREE	1
7	V059112	HHCS 1/2-20UNF X 1 1/4 GR5 ZN	5
8	V155610	SEAL, GREASE	2
9	V155612	BW PART	2
10	V180219	CASTER WLDT, SINGLE	1
11	V180225	BW ASSEMBLY	1
12	V180231	BW PART	1
13	V180290	RIM AND TIRE ASSY.	1

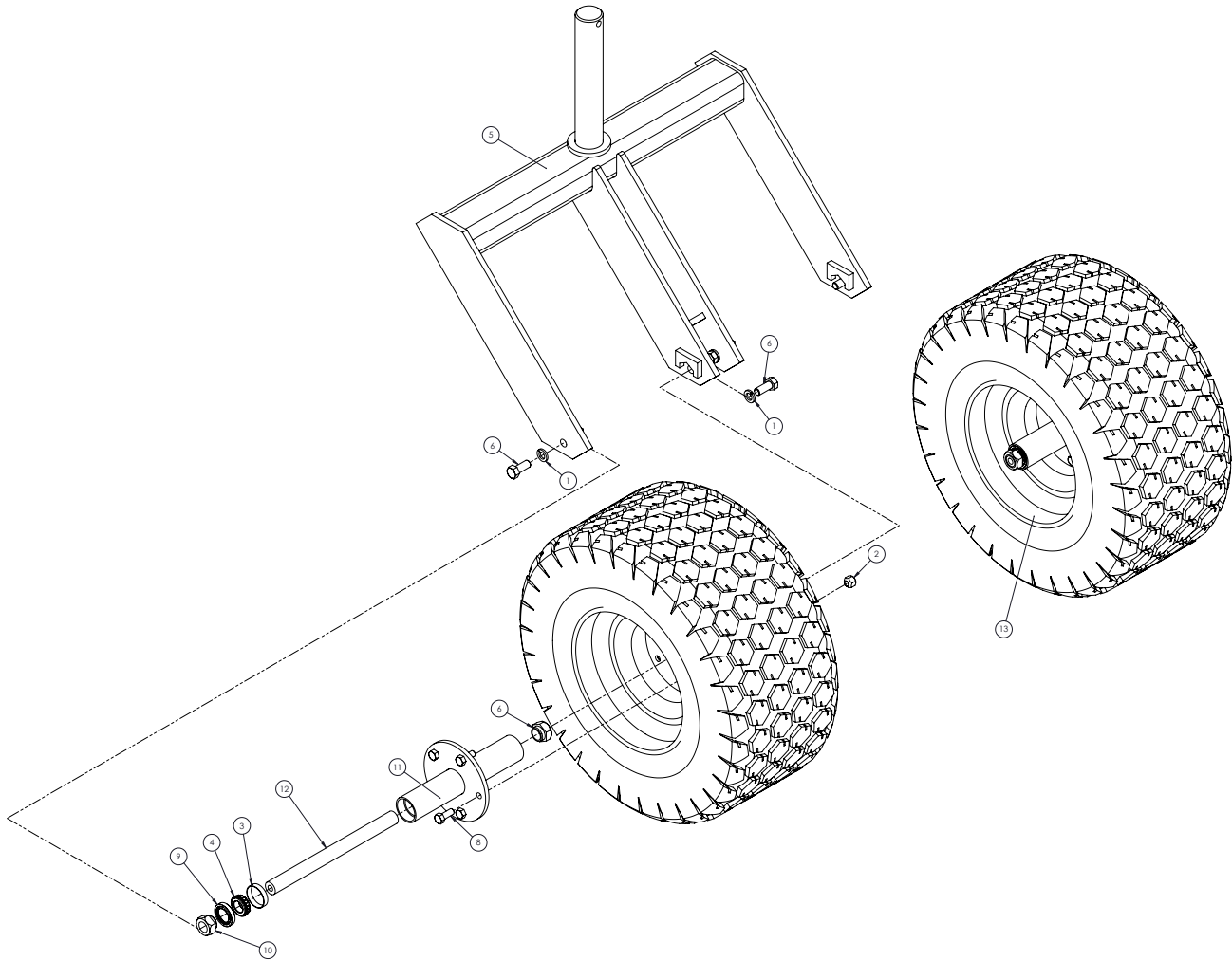

ITEM NO.	PART NUMBER	DESCRIPTION	QTY.
1	020440	WASHER, LOCK 5/8	4
2	020730	HTNUT 0.5000-20-D-N	10
3	169920	BEARING, CUP	4
4	169930	BEARING, CONE	4
5	599510	CASTER WLDT, DUAL	1
6	990610	BOLT, HHCS 5/8-11 X 1-1/2"	4
7	V006005	FITTING, 1/8 NPT 45 DEGREE	2
8	V059112	HHCS 1/2-20UNF X 1 1/4 GR5 ZN	10
9	V155610	SEAL, GREASE	4
10	V155612	BW PART	4
11	V180225	BW ASSEMBLY	2
12	V180231	BW PART	2
13	V180290	RIM AND TIRE ASSY.	2

SINGLE WHEEL ASSEMBLY, FRAME

DOUBLE WHEEL ASSEMBLY, FRAME

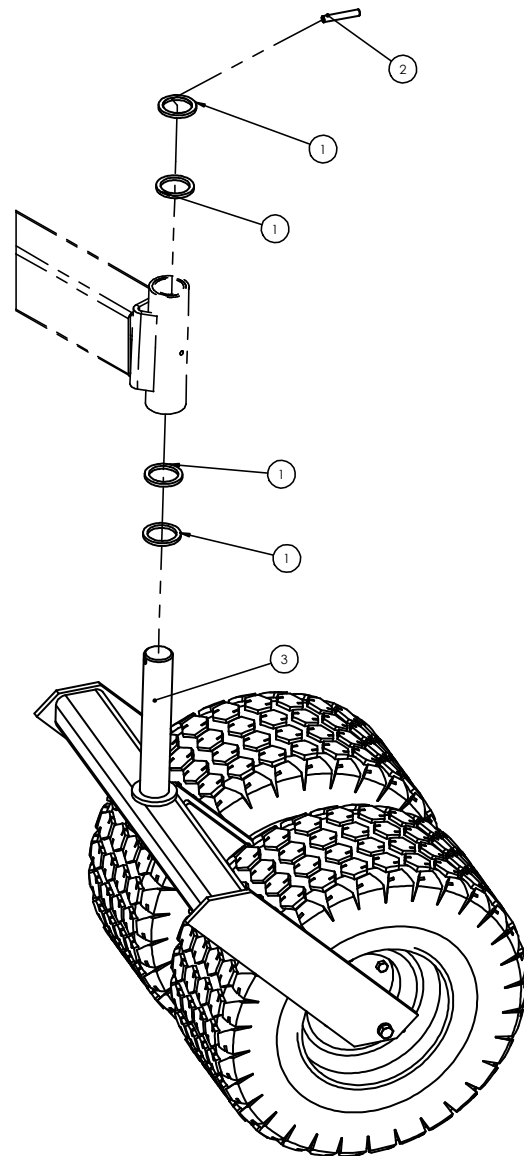
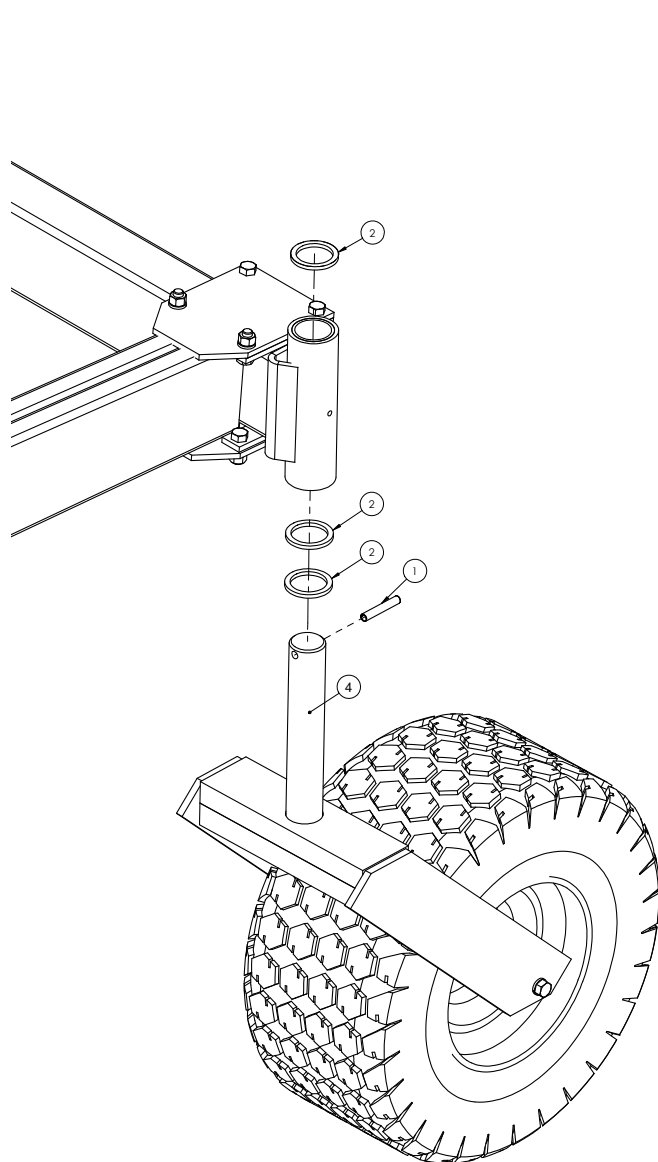

ITEM NO.	PART NUMBER	DESCRIPTION	QTY.
1	V064499	PIN, ROLL 1/2 x 3 ZN SLOTTED	2
2	V180428	WASHER, SPECIAL	6
3	V180865	DUAL CASTER ASSY,	2
4	V180274	SINGLE CASTER ASSY,	2

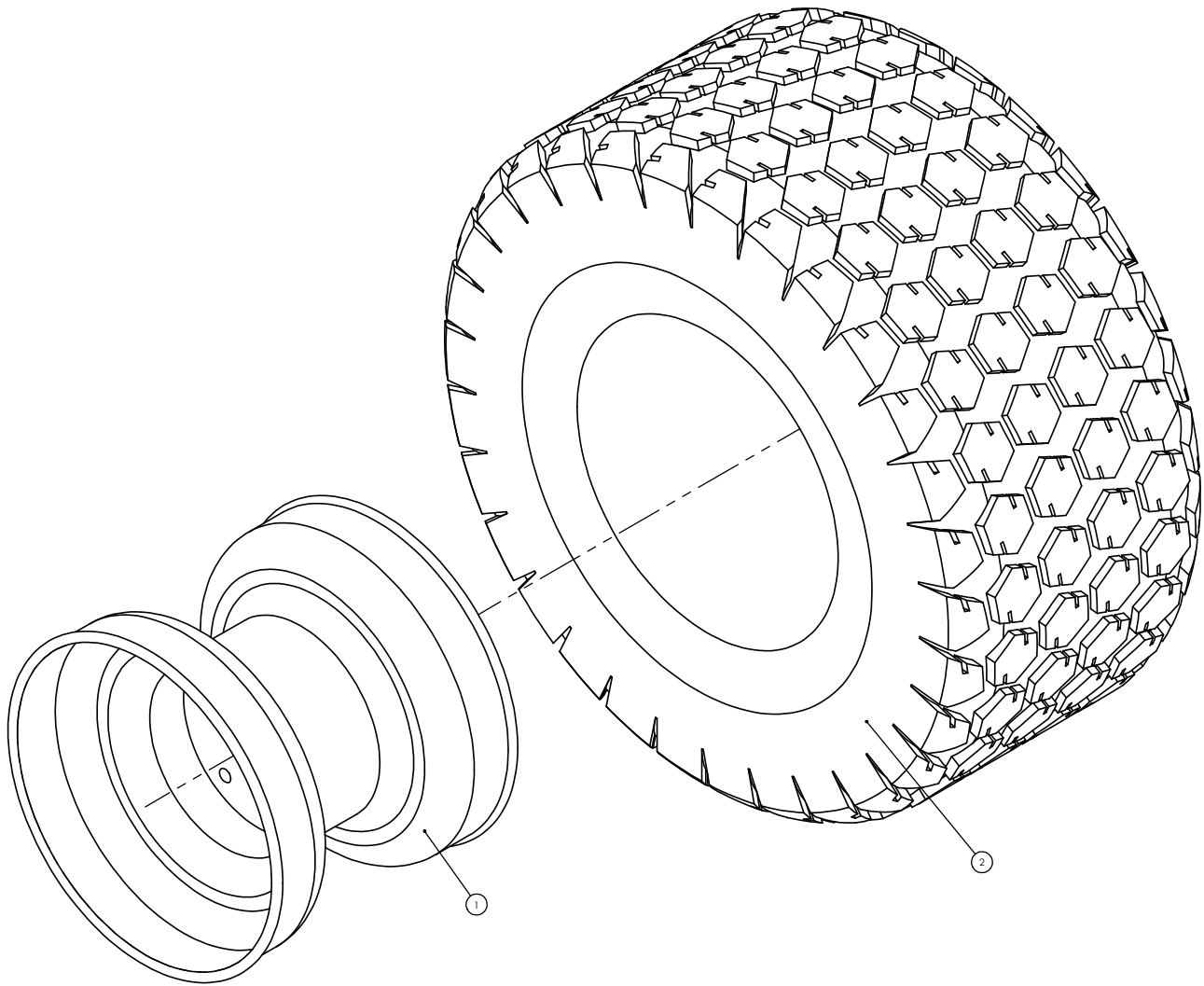

ITEM NO.	PART NUMBER	DESCRIPTION	QTY.
1	V180257	RIM	1
2	V180255	TIRE	1







OPERATOR:

---

NOTES:



**NOTES:**







## **Art's Way Manufacturing TECHNICAL MANUALS**

Manuals are available from your local dealer or Art's Way Manufacturing for the operation, service, and repair of your machine. For prompt convenient service, contact your local dealer for assistance in obtaining the manuals for your machine.

Manuals are also available at [WWW.ARTSWAY.COM](http://WWW.ARTSWAY.COM) free to download for your convenience.

Always give the Machine Name, Model, and Serial Number so your local dealer can provide the correct manuals for your machine.

Art's Way Manufacturing reserves the right to make improvements in design or changes in specifications at any time without incurring any obligation to install them on units previously sold.

Except as expressly authorized, no part of this manual may be reproduced, copied, transmitted, or disseminated, in any storage medium, for any purpose without the express prior written consent of Art's Way Manufacturing

**Art's Way Manufacturing**  
**Armstrong, Iowa, 50514, (712) 208-8467.**

**[WWW.ARTSWAY.COM](http://WWW.ARTSWAY.COM)**